

British Railways Board

Mechanical & Electrical Engineering Department

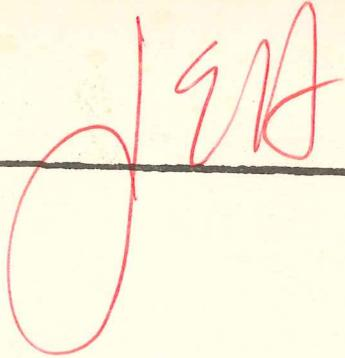

VEHICLE DIAGRAM BOOK NO 300

FOR

UNCONTROLLED COPY
WILL NOT BE KEPT UP TO DATE

Privately Owned Freight Vehicles (Part 3)

© COPYRIGHT NOTICE

This PDF file has been created from the original book with permission of BRB (Residuary) Ltd who, including the relevant successor organisation, retains copyright in the original document.

This PDF version courtesy of Chris Dugdale, 2016.

Individuals may: use, retain and print out this PDF version for their private information or for that of their non-commercial enthusiast society or railway club.

This document and any copies produced from it in any form may not be sold or lent for any payment in any form other than to cover copying or transmission costs.

No reproduction permitted in any other form or circumstance without prior permission from the original copyright holder.

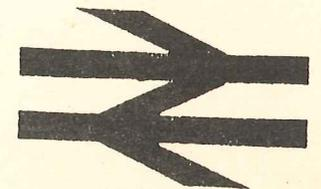

ADDITION TO PRIVATE OWNER INDEX

(TT-TU)

<u>DIAGRAM</u>	<u>DESCRIPTION</u>	<u>OWNER</u>	<u>REG Nos</u>
TT018K	46t GLW Tank wagon CO2	S.T.S.	STS 53213
TU005B	51t GLW Tank wagon	Tiger Rail	TRL 70900 - 31

ADDITION TO PRIVATE OWNED INDEX

(TT -- TU)

<u>DIAGRAM NO.</u>	<u>DESCRIPTION</u>	<u>OWNER</u>	<u>REG. NO.</u>
TT020C	46t Tank Wagon	T.R.L.	51408 - 409
TT031D	46t Tank Wagon Class B	BRT & E	BRT 07747 - 820
TT035G	46t Tank Wagon Class A	BP Oil	BPO 37084,98,99
TT061B	41t Tank Wagon Bitumen	Procor	PR 57323 - 344
TT070D	46t Tank Wagon	BR T & E	BRT 57135
TT079A	46t Tank Wagon	Algeco	ALG 49367 -90
TT088E	46t Tank Wagon	BP Oil	BPO 37094 - 97 37181 - 87

ADDITION TO PRIVATE OWNED INDEX

(TT - TU)

<u>DIAGRAM NO.</u>	<u>DESCRIPTION</u>	<u>OWNER</u>	<u>REG. NO.</u>
TT042G	46t Tank Wagon cls A	Gulf Oil	Gulf 54200-224
TT042J	46t Tank Wagon cls A	Gulf Oil	Gulf 54225-41,56
TT042K	46t Tank Wagon cls A	Gulf Oil	Gulf 54200-256
TT042N	46t Tank Wagon cls A	Gulf Oil	Gulf 54206,216, 222,224
TT042P	46t Tank Wagon cls A	Gulf Oil	Gulf 54250
TT042Q	46t Tank Wagon cls A	Gulf Oil	Gulf 54237
TT042R	46t Tank Wagon cls A	Gulf Oil	Gulf 54200,229, 232,225
TT042S	46t Tank Wagon cls A	Gulf Oil	Gulf 54249

ADDITION TO PRIVATE OWNED INDEX

(TT -- TU)

<u>DIAGRAM NO.</u>	<u>DESCRIPTION</u>	<u>OWNER</u>	<u>REG. NO.</u>
TT043K	46t Tank wagon	Esso	ESSO 6104-6199
TT045C	46t Tank wagon	Esso	ESSO 6200-6240
TT077A	46t Tank wagon (class A)	Railease	RLS 55500-55509
TT077B	46t Tank wagon	T.R.L.	TRL 55510-55519

ADDITION TO PRIVATE OWNED INDEX

(TT - TU)

<u>DIAGRAM NO.</u>	<u>DESCRIPTION</u>	<u>OWNER</u>	<u>REG. NO.</u>
TT017K	46t tank wagon LPG	Esso	ESSO 56350
TT017L	46t tank wagon LPG	Esso	ESSO 56353,354,358, 56359,364
TT017M	46t tank wagon LPG	Esso	ESSO 56368,374
TT017N	46t tank wagon LPG	Esso	ESSO 56376,378,382, 56383,384
TT017P	46t tank wagon LPG	Esso	ESSO 56387-403(range)
TT042H	46t tank wagon cls A	Gulf	GULF 54242-255(range)
TT042L	46t tank wagon cls A	Gulf	GULF 54242,249
TT042M	46t tank wagon cls A	Gulf	GULF 54243,245

ADDITION TO PRIVATE OWNED INDEX

(TT - TU)

<u>DIAGRAM NO.</u>	<u>DESCRIPTION</u>	<u>OWNER</u>	<u>REG. NO.</u>
TT072F	46t tank wagon (class A)	T.R.L.	TRL 51954-60 TRL 51964-68
TT072G	46t tank wagon	T.R.L.	TRL 51961-63
TT073C	46t tank wagon	STS	STS 53268
TT073D	46t tank wagon	STS	STS 53282
TT075B	46t tank wagon	Ass. Octal	
TT075C	46t tank wagon	Ass. Octal	AO 55325-338
TT088K	46t tank wagon (cls B)	Shell	SUKO 67000-67059 67100-67135 67444-550,756
TT088T	46t tank wagon	B.P. Oil	BPO 60560,1,2,
TT088U	46t tank wagon (cls A)	Shell	SUKO 67403-931(range)
TT088V	46t tank wagon	Shell	SUKO 67326-348(range) 67457
TT088W	46t tank wagon (cls A)	Shell	SUKO 67959
TT088X	46t tank wagon (cls A)	Shell	SUKO 67958
TT088Y	46t tank wagon (cls A)	Shell	SUKO 67200-210
TT088Z	46t tank wagon (cls A)	Shell	SUKO 67135-67159
TT090A	46t tank wagon		
TT090C	46t tank wagon	Ass. Octal	AO 55357
TT091A	46t tank wagon (cls B)	B.P. Oil	BPO 65678,85,762,764 65675,82,94
TT091B	46t tank wagon (cls A)	Shell	SUKO 60515,16,17,18
TT091C	46t tank wagon (cls A)	Shell	SUKO 60514
TT091D	46t tank wagon (cls A)	Shell	SUKO 67346-402(range)
TT091E	46t tank wagon (cls A)	Shell	SUKO 60522-43
TT091F	46t tank wagon (cls A)	B.P.Oil	BPO 60569-90(range)

<u>DIAGRAM NO.</u>	<u>DESCRIPTION</u>	<u>OWNER</u>	<u>REG. NO.</u>
TT091G	46t tank wagon (cls A)	B.P.Oil	BPO 60563
TT091H	46t tank wagon (cls B)	B.P.Oil	BPO 66278,84,92,94, 66361,65,67
TT091J	46t tank wagon (cls A)	Shell	SUKO 60603-60632
TT091K	46t tank wagon (cls A)	Shell	SUKO 60622,33,34
TT091L	46t tank wagon (cls A)	Shell	SUKO 60601,02,40,41
TT091M	46t tank wagon	B.P.Oil	BPO 66174,80,86,92
TT091N	46t tank wagon (cls A)	Shell	SUKO 67200-321(range) 60512
TT091P	46t tank wagon (cls A)	Shell	SUKO 60501-09
TT091Q	46t tank wagon (cls A)	Shell	SUKO 60658,59, 60701-10(range)
TT091R	46t tank wagon (cls A)	B.P.Oil	BPO 60593,664,665,672
TT091S	46t tank wagon (cls A)	B.P.Oil	BPO 60683,691
TT091T	46t tank wagon (cls A)	Shell	SUKO 60223
TT091U	46t tank wagon	Shell	SUKO 60104-251(range)
TT091V	46t tank wagon (cls A)	Shell	SUKO 67953,55,56,57
TT091W	46t tank wagon (cls A)	Esso	ESSO 66139,219
TT091X	46t tank wagon (cls B)	Esso	ESSO 66318
TT091Y	46t tank wagon (cls B)	Esso	ESSO 66127,28,32,35, 207,214
TT091Z	46t tank wagon (cls B)	Esso	ESSO 66230,233,316, 317
TT092A	42.5t tank wagon	B.P.Oil	BPO 59188-98(range)
TT092B	42.5t tank wagon	B.P.Oil	BPO 59186,87,97
TT092C	42.5t tank wagon	B.P.Oil	BPO 59685,89,92
TT092D	46t tank wagon	B.P.Oil	BPO 63591,79,694
TT092E	42.5t tank wagon (LPG)	B.P.Oil	BPO 59686-95(range)
TT092F	42.5t tank wagon (LPG)	B.P.Oil	BPO 59696
TT092G	42.5t tank wagon (LPG)	B.P.Oil	BPO 59684

<u>DIAGRAM NO.</u>	<u>DESCRIPTION</u>	<u>OWNER</u>	<u>REG. NO.</u>
TT092H	42.5t tank wagon (LPG)	B.P.Oil	BPO 59697-99
TT092J	42.5t tank wagon (LPG)	B.P.Oil	BPO 59693,94
TT093A	46t tank wagon (cls A)	B.P.Oil	BPO 37360-65
TU006D	51t tank wagon (bitumen) lagged & coiled	Shell	SUKO 71500
TU014B	51t tank wagon (cls A)	T.R.L	TRL 70728-33

ADDITION TO PRIVATE OWNED INDEX

(TT - TU)

<u>DIAGRAM NO.</u>	<u>DESCRIPTION</u>	<u>OWNER</u>	<u>REG. NO.</u>
TT059L	46t tank wagon cls B	BP Oil	BPO 63261-93,63566-63875 (range)
TT059M	46t tank wagon cls B	BP Oil	BPO 63560-894 (range)
TT059Q	46t tank wagon (bitumen)	BP Oil	BPO 61592,61691,61666
TT059R	46t tank wagon cls A	Shell	SUKO 67932
TT059T	46t tank wagon LPG	BP Oil	BPO 59595
TT059U	46t tank wagon LPG	BP Oil	BPO 59596,7
TT059V	46t tank wagon (bitumen)	BP Oil	BPO 61583-680(range)
TT059W	46t tank wagon (bitumen)	BP Oil	BPO 61691
TT059X	46t tank wagon cls B (lagged and coiled)	Shell	SUKO 63201,03,06,12, 16
TT060G	46t tank wagon cls B	BP Oil	BPO 63898,99
TT063E	46t tank wagon	BP Oil	BPO 61574
TT063F	46t tank wagon	BP Oil	BPO 61561-61581
TT066Q	46t tank wagon cls B (lagged and coiled)	ESSO	ESSO 64123,24,25, 64601,25,28
TT066R	46t tank wagon cls B	ESSO	ESSO 64326-536(range)
TT066S	46t tank wagon	ESSO	ESSO 64221,64222
TT066T	46t tank wagon cls B (lagged & coiled)	ESSO	ESSO 64416,64425, 64520
TT066U	46t tank wagon cls B	ESSO	ESSO 64258
TT066V	46t tank wagon cls B	ESSO	ESSO 64607,38,40 46, 64710
TT066W	46t tank wagon cls B	ESSO	ESSO 64331-540(range)
TT067E	46t tank wagon (acetic acid,ethanol)	STS	STS 53313-44
TT070E	46t tank wagon (caustic liquor)	PROCOR	PR 58509-581(range)

<u>DIAGRAM NO.</u>	<u>DESCRIPTION</u>	<u>OWNER</u>	<u>REG. NO.</u>
TT070F	41t tank wagon (molasses)	PROCOR	PR 58502-531(range)
TT072C	46t tank wagon	T.R.L.	TRL 51625-51629 51619,20,21,24
TT072D	46t tank wagon (clay slurry)	T.R.L	TRL 51631-48(range)
TT072E	46t tank wagon	T.R.L	TRL 51618

ADDITION TO PRIVATE OWNED INDEX

(TT - TU)

<u>DIAGRAM NO.</u>	<u>DESCRIPTION</u>	<u>OWNER</u>	<u>REG. NO.</u>
TT001R	41t tank wagon	B.P. Oil	BPO 59173,75,77, 78

TARE AND CARRYING CAPACITY

The policy respecting this information is as follows :-

- a) The tare shown on any diagram is a specimen weight, usually the 1st Wagon built.
- b) The painted tare on each vehicle shall be the actual recorded weight rounded down to the nearest 50 kg.
- c) The carrying capacity shown on any diagram is the metricated carrying capacity rounded off to the nearest 500 kg.
- d) The painted carrying capacity shall be to the nearest single decimal place and is the difference between the G.L.W. and the painted tare.

For existing wagons the G.L.W. is the exact metric equivalent of the original imperial G.L.W.

For new wagons the carrying capacity will depend upon the G.L.W. used in the submission and Builders will be advised of the agreed capacity when registration numbers are issued.

ADDITION TO PRIVATE OWNED INDEX

(TT - TU)

<u>DIAGRAM NO.</u>	<u>DESCRIPTION</u>	<u>OWNER</u>	<u>REG. NO.</u>
TT001S	41t tank wagon LPG	Shell	SUKO 595111-45 (range)
TT001T	46t tank wagon LPG	B.P.Oil	BPO 59598-683(range)
TT002N	41t tank wagon LPG	Shell	SUKO 59552-609(range)
TT002P	46t tank wagon cls A	Shell	SUKO 60519,20
TT002Q	46t tank wagon cls A	Shell	SUKO 60521
TT002R	41t tank wagon LPG	Shell	SUKO 59646
TT003E	41t tank wagon LPG	B.P.Oil	BPO 59174,76
TT003F	41t tank wagon LPG	B.P.Oil	
TT017F	46t tank wagon LPG	Esso	
TT017G	46t tank wagon LPG	Esso	
TT017H	46t tank wagon LPG	Esso	
TT017J	46t tank wagon LPG	Esso	
TT018H	46t tank wagon CO2	STS	STS 53203
TT018J	46t tank wagon CO2	STS	STS 53218
TT019G	46t tank wagon cls A	VTG (UK)	ALG 49057-62 49068-75
TT020G	46t tank wagon cls A	Texaco	TEX 54812,14,15,
TT025B	46t tank wagon	T.R.L.	TRL 51776
TT026Y	46t tank wagon cls A	B.P.Oil	BPO 60197
TT027Q	46t tank wagon	Charrington Fuel	53741-53750 53752-53761
TT027R	46t tank wagon cls B	Charingtons Fuel	53771-53772
TT029T	46t tank wagon	E.G.Steele	STL 54855-66 54868-69
TT031E	46t tank wagon cls B (close coupled)	BRT & E	BRT 57795
TT032D	46t tank wagon cls A	S.T.S.	STS 53082-88

ADDITION TO PRIVATE OWNED INDEX

(TT - TU)

<u>DIAGRAM NO.</u>	<u>DESCRIPTION</u>	<u>OWNER</u>	<u>REG. NO.</u>
TT033C	46t tank wagon cls A	Esso	ESSO 45232
TT034G	46t tank wagon cls A	Shell	SUKO 60605-644(range)
TT034H	46t tank wagon cls A	Shell	SUKO 60645-712(range)
TT034K	46t tank wagon cls A	Shell	SUKO 60650,57,708,722 723,724
TT034L	46t tank wagon cls B	Esso	ESSO 66319,24,26,37,
TT034M	46t tank wagon (grease)	Esso	ESSO 66343
TT035J	46t tank wagon cls B	Esso	ESSO 64107,64113
TT035K	46t tank wagon cls B	Esso	ESSO 64131,32
TT035L	46t tank wagon cls A	Shell	SUKO 60639
TT035M	46t tank wagon cls A	Shell	SUKO 60713,14
TT035N	46t tank wagon cls A	Esso	ESSO 66101,66105
TT035P	46t tank wagon cls B	Esso	ESSO 66113
TT035Q	46t tank wagon cls B	Esso	ESSO 64104,105,110, 64114,
TT036C	46t tank wagon cls B	Charrington Fuel	53721-53727 53729-53738
TT036D	46t tank wagon cls B	Charrington Fuel	53762,53739, 53740
TT040D	46t tank wagon cls A	Procor	PR 55204-244(range)
TT043R	46t tank wagon cls A	Esso	ESSO 56001-19(range)
TT043S	46t tank wagon cls A	Esso	ESSO 56000
TT043T	46t tank wagon cls A	B.R.T.	BRT 57838,40
TT043U	46t tank wagon cls A	Esso	ESSO 56243-280(range)
TT043V	46t tank wagon (close coupled)	Esso	ESSO 56010-195(range)

ADDITION TO PRIVATE OWNED INDEX

(TT - TU)

<u>DIAGRAM NO.</u>	<u>DESCRIPTION</u>	<u>OWNER</u>	<u>REG. NO.</u>
TT043X	46t tank wagon cls A (close coupled)	B.R.T.	BRT 57484,87,90,93, 502,511
TT045H	46t tank wagon cls A	Esso	ESSO 56208-237(range)
TT045J	46t tank wagon cls B	B.R.T.& E	BRT 57672-696(range)
TT049W	46t tank wagon (hydrochloric acid)	Procor	PR 58207,8
TT049X	46t tank wagon (caustic soda liquor)	Procor	PR 58200,201,203, 212,217,221
TT049Y	46t tank wagon (sodium hypochlorite)	Procor	PR 58211
TT049Z	46t tank wagon (sodium hypochlorite)	Procor	PR 58213,14,16
TT051G	46t tank wagon	T.R.L.	TRL 51410-14,51416- 425,51427,28,30
TT051L	46t tank wagon (sulphuric acid)	T.R.L.	TRL 51100-16
TT053K	41t tank wagon (molasses)	Procor	PR 58602-60(range)
TT053L	41t tank wagon (molasses)	Procor	PR 58574,58521
TT055D	46t tank wagon	S.T.S.	STS 53220,27,21,22 53232
TT055E	46t tank wagon	S.T.S.	STS 53239,42,47
TT058G	46t tank wagon cls B (lagged & coiled)	BP Oil	BPO 63162-99(range)
TT059K	46t tank wagon cls B (lagged & coiled)	Shell	SUKO 63814-817 63819-820
TT066J	46t tank wagon cls B	BP Oil	BPO 63294
TT072A	46t tank wagon	T.L. Ltd	51589-51648

ADDITION TO PRIVATE OWNED INDEX

(TT - TU)

<u>DIAGRAM NO.</u>	<u>DESCRIPTION</u>	<u>OWNER</u>	<u>REG. NO.</u>
TT017A	46t Tank L.P.G.	Esso	56341 - 56356 (range)
TT017E	46t Tank L.P.G.	Esso	56385 - 56406 (range)
TT059S	46t Tank bitumen	Shell UK	SUKO 61345,46,47,48

DIAGRAM	DESCRIPTION	OWNER	REGISTRATION NUMBERS
TT001A	2 Axle Tank Wagon	Algeco	ALG 49291-316
TT001C	2 Axle Tank Wagon	Shell (UK) Oil	SUKO 59113-23
TT001F	2 Axle Tank Wagon	BP Oil Ltd	BPO 59560-73
TT001G	2 Axle Tank Wagon	C.L.M.I.	CLMI 54013-6
TT001H	2 Axle Tank Wagon	BP Oil Ltd	BPO 59161-5
TT001J	2 Axle Tank Wagon	BP Oil Ltd	BPO 59160, 6, 7
TT001K	2 Axle Tank Wagon	Shell (UK) Oil	SUKO 59439, 40, 500-512, 514-537, 539-545
TT001L	2 Axle Tank Wagon	Shell (UK) Oil	SUKO 59407
TT001M	2 Axle Tank Wagon	Shell (UK) Oil	SUKO 59401, 02, 08
TT001N	2 Axle Tank Wagon	Shell (UK) Oil	SUKO 59403-11 (RANGE)
TT001P	2 Axle Tank Wagon	BP Oil Ltd	BPO 59560-73
TT001Q	2 Axle Tank Wagon	C.L.M.I.	CLMI 54013-6
TT002D	2 Axle Tank Wagon	BP Oil Ltd	BPO 59574-82
TT002E	2 Axle Tank Wagon	BP Oil Ltd	BPO 59583-88
TT002G	2 Axle Tank Wagon	Shell (UK) Oil	SUKO 59546-559, 600-612
TT002H	2 Axle Tank Wagon	Shell (UK) Oil	SUKO 59513-32
TT002J	2 Axle Tank Wagon	Shell (UK) Oil	SUKO 59633-37, 39-50
TT002K	2 Axle Tank Wagon	BP Oil Ltd	BPO 59574-82
TT002L	2 Axle Tank Wagon	BP Oil Ltd	BPO 59583-88
TT002M	2 Axle Tank Wagon	BP Oil Ltd	BPO 59589-94
TT003A	2 Axle Tank Wagon	Shell (UK) Oil	SUKO 59124-38
TT003B	2 Axle Tank Wagon	BP Oil Ltd	BPO 59168
TT003C	2 Axle Tank Wagon	BP Oil Ltd	BPO 59169-72
TT003D	2 Axle Tank Wagon	BP Oil Ltd	BPO 59168
TT004A	2 Axle Tank Wagon	Hargreaves Fuel Oil	HFO 53901-04, 06-21
TT004B	2 Axle Tank Wagon	BP Oil and Shell (UK) Oil	BPO 50160-7, 65060, SUKO 50100-12
TT004C	2 Axle Tank Wagon	Tiger Railcar Leasing	TRL 51299-338
TT005A	2 Axle Tank Wagon	Brit Rail Traffic & Elec	BRT 57000-12, 14-17, 19-21, 23-40
TT005B	2 Axle Tank Wagon	Brit Rail Traffic & Elec	BRT 57345-49

DIAGRAM	DESCRIPTION	OWNER	REGISTRATION NUMBERS
TT006A	2 Axle Tank Wagon	Storage & Transport Systems	STS 53012-50, 52-60
TT007A	2 Axle Tank Wagon	Charrington Garner Locket	CGL 53701-06, 08-20
TT007B	2 Axle Tank Wagon	Hargreaves Fuel Oil	HFO 53905
TT007C	2 Axle Tank Wagon	Tiger Railcar Leasing	TRL 51222-32
TT007D	2 Axle Tank Wagon	Tiger Railcar Leasing	TRL 51258-79
TT008A	2 Axle Tank Wagon	Algeco Ltd	ALG 49000-5
TT008B	2 Axle Tank Wagon	Brit Railway Traffic & Elec	BRT 57295-305
TT008C	2 Axle Tank Wagon	Tiger Railcar Leasing	TRL 51281-98
TT009A	2 Axle Tank Wagon	Tiger Railcar Leasing	TRL 51166
TT009B	2 Axle Tank Wagon	Tiger Railcar Leasing	TRL 51177-96
TT010A	2 Axle Tank Wagon	Storage & Trans Systems	STS 53250-61, 63, 64
TT010B	2 Axle Tank Wagon	Tiger Railcar Leasing	TRL 51450-538
TT010C	2 Axle Tank Wagon	I.C.I. (Agriculture)	ICIA 54301-50
TT010D	2 Axle Tank Wagon	I.C.I. (Agriculture)	ICIA 54381-413
TT012A	2 Axle Tank Wagon	Shell (UK) Oil	SUKO 52155, 56, 58, 59, 200-04, 07-29
TT012C	2 Axle Tank Wagon	Shell (UK) Oil	SUKO 52230-259, 300-344
TT013B	2 Axle Tank Wagon	Shell (UK) Oil	SUKO 50500
TT013C	2 Axle Tank Wagon	Procor (UK) Ltd	PR 58910-35
TT014A	2 Axle Tank Wagon	Fisons Fertilisers	FF55409-12
TT015A	2 Axle Tank Wagon	Powell Duffryn	PDUF 52000-27
TT016A	2 Axle Tank Wagon	Shell (UK) Oil Ltd	SUKO 52100-02, 04-18, 20, 22-26, 28-34, 36-38, 40, 42-54

DIAGRAM	DESCRIPTION	OWNER	REGISTRATION NUMBERS
TT017A	2 Axle Tank Wagon	Esso Petroleum	ESSO 56341, 42, 44-48, 50, 51, 56
TT017B	2 Axle Tank Wagon	Esso Petroleum	ESSO 56343, 49, 52-55, 57-62, 64, 65, 69, 70, 73
TT017C	2 Axle Tank Wagon	Esso Petroleum	ESSO 56363, 61-68, 71, 72, 74
TT017D	2 Axle Tank Wagon	Esso Petroleum	ESSO 56375-84
TT017E	2 Axle Tank Wagon	Esso Petroleum	ESSO 56385-406
TT018A	2 Axle Tank Wagon	Brit Rail Traffic & Elect	BRT 57577-87
TT018B	2 Axle Tank Wagon	Brit Rail Traffic & Elect	BRT 57881-86
TT018C	2 Axle Tank Wagon	Storage & Trans System	STS 53215-18
TT018D	2 Axle Tank Wagon	Storage & Trans System	STS 53200-07
TT018E	2 Axle Tank Wagon	Storage & Trans System	STS 53208-14
TT019A	2 Axle Tank Wagon	Algeco & C.L.M.I.	ALG 49006-22, 24-56, 76-82, 366. CLMI 54018-21, 23-32
TT019B	2 Axle Tank Wagon	Algeco	ALG 49084, 5, 6
TT019C	2 Axle Tank Wagon	Algeco	ALG 49057-62, 68-75
TT019D	2 Axle Tank Wagon	Algeco	ALG 49063-67
TT019E	2 Axle Tank Wagon	Algeco	ALG 49023
TT019F	2 Axle Tank Wagon	Algeco	ALG 49083
TT020A	2 Axle Tank Wagon	Hargreaves Fuel Oil	HFO 54941-43
TT020B	2 Axle Tank Wagon	Tiger Railcar Leasing	TRL 51382-403, 405-407
TT020C	2 Axle Tank Wagon	Tiger Railcar Leasing	TRL 51408, 9
TT020D	2 Axle Tank Wagon	Texaco	TEX 54812, 14, 15, 17, 19, 21, 23, 24, 26, 27, 29, 34
TT020E	2 Axle Tank Wagon	Hargreaves Fuel Oil	HFO 53951-8
TT020F	2 Axle Tank Wagon	W.H. Davis Ltd	DAVS 54810, 11, 13, 16, 18, 20, 22, 25, 28, 30, 31, 32, 33
TT021A	2 Axle Tank Wagon	I.C.I. (Agriculture)	ICIA 54351-80
TT021B	2 Axle Tank Wagon	Procor	PR 58136-55
TT022A	2 Axle Tank Wagon	Tiger Railcar Leasing	TRL 51435-37, 39, 40, 42-45, 47-49
TT022B	2 Axle Tank Wagon	Tiger Railcar Leasing	TRL 514c38, 46
TT022C	2 Axle Tank Wagon	Tiger Railcar Leasing	TRL 51948, 51, 52
TT022D	2 Axle Tank Wagon	Tiger Railcar Leasing	TRL 51949, 50
TT023B	2 Axle Tank Wagon	Petrofina	FINA 54701-30

DIAGRAM	DESCRIPTION	OWNER	REGISTRATION NUMBERS
TTO24A	2 Axle Tank Wagon	Procor	PR 58101-35
TTO25A	2 Axle Tank Wagon	Tiger Railcar Leasing	TRL 51764-803
TTO26A	2 Axle Tank Wagon	Algeco & C.L.M.I.	ALG 49317-64. CLMI 54017
TTO26B	2 Axle Tank Wagon	Brit Rail Traffic & Elect	BRT 57638-53, 55, 56, 58, 59, 60, 62, 63
TTO26C	2 Axle Tank Wagon	BP Oil & Shell (UK) Ltd	BPO 60560-8. SUKO 60501-11
TTO26D	2 Axle Tank Wagon	BP Oil & Shell (UK) Ltd	BPO 60569-679. SUKO 65500-59, 600-17
TTO26E	2 Axle Tank Wagon	BP Oil & Shell (UK) Ltd	BPO 37188-95, 60680-94, 67260-299, 360-373. SUKO 60412, 3, 67200-57, 300-23
TTO26F	2 Axle Tank Wagon	BP Oil & Shell (UK) Ltd	BPO 65675, 78, 82, 85-87, 90, 91, 94, 761, 762, 764, 766. SUKO 65618-59, 700-11
TTO26H	2 Axle Tank Wagon	BP Oil, Shell (UK) Oil and Esso Petroleum) BPO 60299, 360-62, 67, 66172, 74, 76, 77, 79, 80, 81,) 82, 84, 86, 88-93, 96, 262-266, 269-271. SUKO 66101,) 02, 05, 07, 08, 10, 12, 13, 15-18, 20, 22, 24,) 26-28, 31-35, 37, 39, 41, 43-47, 49, 51, 53, 205, 207) 209-212, 214, 215, 219, 221, 222. ESSO 66127, 28, 32,) 35, 39, 53, 207, 214, 219
TTO26J	2 Axle Tank Wagon	BP Oil, Shell (UK) Oil and Esso Petroleum) BPO 60363-6, 66272, 73, 74, 78, 82, 83, 84, 88, 90-94,) 97, 98, 360, 362, 364, 365, 367. SUKO 66223, 25,) 27, 29, 30, 33, 40, 45, 47, 48, 51, 53, 55, 56, 57,) 301, 02, 03, 08, 12, 15-18. ESSO 66230, 233, 316,) 317, 318
TTO26K	2 Axle Tank Wagon	BP Oil and Shell (UK) Oil) BPO 60695-699, 760, 67061, 066, 072, 076, 080-082,) 086-088, 094, 161, 162, 175, 179, 182, 187-189,) 194, 461, 471, 476, 484, 485, 487, 492-494, 497, 498,) 562, 564, 568, 573, 583, 589, 591, 592, 594, 597,) 664-666, 670, 673-675, 690, 760, 761, 765, 767, 771,) 775, 779, 781, 788, 789, 791, 792, 796, 860-862, 868,) 870, 874, 878, 879, 883, 885, 887, 890-893, 895-898,) 960, 965, 972-974. SUKO 67000-59, 100-159, 403-459,) 500-559, 800-859, 900-931.

2301/0585f/4

DIAGRAM	DESCRIPTION	OWNER	REGISTRATION NUMBERS
TTO26L	2 Axle Tank Wagon	BP Oil and Shell (UK) Oil) BPO 60160, 167-169, 178-183, 191, 192, 199, 260, 261,) 262, 274-277, 68162, 163, 165, 169, 171, 172, 174,) 175, 177-179, 184-186, 188, 189, 191, 193, 195-198,) 261-264, 267-270, 272-274. SUKO 60100, 113-115,) 122-131, 149-148, 214-220, 68104, 06, 09, 11, 14,) 19, 25, 30, 32, 35, 36, 44, 45, 46, 48, 51, 52, 58,) 200, 01, 04
TTO26M	2 Axle Tank Wagon	BP Oil and Shell (UK) Oil) BPO 60170, 184, 263, 278, 279, 68277. SUKO 60159,) 222, 223, 68205, 07-10, 12-14
TTO26N	2 Axle Tank Wagon	BP Oil and Shell (UK) Oil) BPO 60161-165, 175, 187, 188, 189, 197, 198, 268-270,) 285-293, 68560, 61, 63, 66, 69-72, 75-77, 79, 80,) 82, 84-87, 89. SUKO 60103-12, 34, 41-46, 203-209,) 234-235, 68501, 02, 05, 06, 07, 10, 12-15, 18, 20,) 23, 25, 26, 28, 29, 30, 36, 39, 40, 43-46, 48
TTO26P	2 Axle Tank Wagon	BP Oil & Shell (UK) Oil) BPO 68591-94, 96-99, 661-670, 674. SUKO 68553, 56,) 58, 600, 602, 603, 606, 607, 609, 610, 612, 613,) 617, 619, 620, 623, 626.
TTO26Q	2 Axle Tank Wagon	BP Oil & Shell (UK) Oil	BPO 67374-388. SUKO 60500, 67324-45
TTO26R	2 Axle Tank Wagon	BP Oil & Shell (UK) Oil	BPO 67389-399. SUKO 67346-359, 400-402
TTO26U	2 Axle Tank Wagon	BP Oil	BPO 67981
TTO26V	2 Axle Tank Wagon	BP Oil	BPO 67982
TTO26X	2 Axle Tank Wagon	BP Oil) BPO 37196, 199, 263-267, 269, 270, 67060, 062-065,) 067-071, 073-075, 077-079, 083-085, 089-093, 095-099,) 160, 163-174, 176-178, 180, 181, 183-186, 190-193,) 195-199, 460, 462-470, 472-475, 477-483, 486, 488-491,) 495, 496, 499, 560, 561, 563, 565-567, 569-572,) 574-582, 584-588, 590, 593, 595, 596, 598, 599,) 660-663, 667-669, 671, 672, 676-689, 691-699,) 762-764, 776-778, 780, 782-787, 790, 793-795,) 797-799, 863-867, 869, 871-873, 875-877, 880-882,) 884, 886, 888, 889, 894, 899, 961-964, 966-971,) 975-979

2301/0585f/5

DIAGRAM	DESCRIPTION	OWNER	REGISTRATION NUMBERS
TT026Z	2 Axle Tank Wagon	BP Oil	BPO 37271
TT027A	2 Axle Track Wagon	Charrington Gardner Locket	CGL 53731-35
TT027B	2 Axle Track Wagon	Charrington Gardner Locket	CGL 53741-61
TT027C	2 Axle Track Wagon	Charrington Gardner Locket	CGL 53771-78
TT027D	2 Axle Track Wagon	Brit Rail Traffic & Elect	BRT 57061-66, 68, 71-75
TT027E	2 Axle Track Wagon	Brit Rail Traffic & Elect	BRT 57306, 7
TT027F	2 Axle Track Wagon	Texaco	TEX 54802, 05, 08, 09, 47
TT027J	2 Axle Track Wagon	Brit Rail Traffic & Elect	BRT 57067, 69, 70, 78, 79, 80
TT027K	2 Axle Tank Wagon	Brit Rail Traffic & Elect	BRT 57076, 77, 81-85
TT027L	2 Axle Tank Wagon	W.H. Davis Ltd	DAVS 54800, 01, 03, 04, 06, 07, 35-46, 48-54
TT027M	2 Axle Tank Wagon	Milk Marketing Board	MMB 52866-70
TT028A	2 Axle Tank Wagon	Brit Rail Traffic & Elect	BRT 57193
TT029A	2 Axle Tank Wagon	Brit Rail Traffic & Elect	BRT 57308-22
TT029B	2 Axle Tank Wagon	Brit Rail Traffic & Elect	BRT 57845, 8, 9
TT029C	2 Axle Tank Wagon	Brit Rail Traffic & Elect	BRT 57092, 93, 95, 97-99, 101, 103, 104, 107, 109-111, 119, 126, 127
TT029D	2 Axle Tank Wagon	Brit Rail Traffic & Elect)	BRT 57088-91, 94, 96, 100, 102, 105, 106, 108, 112-118, 120-125, 128-131, 134, 136-141
TT029F	2 Axle Tank Wagon	Brit Rail Traffic & Elect	BRT 57664-9
TT029K	2 Axle Tank Wagon	Brit Rail Traffic & Elect	BRT 57846, 47, 50
TT029L	2 Axle Tank Wagon	W.H. Davis	DAVS 54855-69
TT029Q	2 Axle Tank Wagon	Shell (UK) Oil	SUKO 65744, 5
TT029R	2 Axle Tank Wagon	Brit Rail Traffic & Elect	BRT 57664-9
TT030D	2 Axle Tank Wagon	E.G. Steele	STL 55001-20
TT030E	2 Axle Tank Wagon	E.G. Steele	STL 55021-44
TT030F	2 Axle Tank Wagon	E.G. Steele	STL 55045-55

2301/0585f/6

DIAGRAM	DESCRIPTION	OWNER	REGISTRATION NUMBERS
TT031A	2 Axle Tank Wagon	Brit Rail Traffic & Elect	BRT 57747-59, 61-95, 97-821
TT031B	2 Axle Tank Wagon	Brit Rail Traffic & Elect	BRT 57796
TT031D	2 Axle Tank Wagon	Brit Rail Traffic & Elect) BRT 57747-50, 54, 55, 57, 59-62, 64, 65, 67, 68,) 70-74, 76, 77, 79, 84, 86, 87, 89-95, 97, 98, 800,) 802, 803, 805, 807, 809-813, 815, 816, 818, 820
TT032A	2 Axle Tank Wagon	Storage & Transport Systems	STS 53062-81
TT032B	2 Axle Tank Wagon	Storage & Transport Systems	STS 53082-91
TT033A	2 Axle Tank Wagon	Tiger Railcar Leasing	TRL 51539-47
TT033B	2 Axle Tank Wagon	Tiger Railcar Leasing	TRL 51549-56, 58, 59, 60
TT034A	2 Axle Tank Wagon	BP Oil and Shell (UK) Ltd) BPO 60176, 77, 90, 271-273, 294-298. SUKO 60120,) 21, 36, 47, 48, 210-213, 60254-9
TT034B	2 Axle Tank Wagon	BP Oil Ltd and Shell (UK) Oil and Esso Petroleum) BPO 60368, 663870, 71, 73, 75-80, 82, 84, 85, 87,) 89, 90. ESSO 66319, 24, 26, 37, 43. SUKO 66319,) 20, 23-26, 28-30, 32, 33, 36, 37, 39, 40, 43, 44,) 46, 47, 49, 51
TT034C	2 Axle Tank Wagon	BP Oil Ltd and Shell (UK) Oil) BPO 60171-173, 185, 186, 193-196, 264-267, 280-284,) 68284, 289, 290, 294-296, 298, 360, 362-366.) SUKO 60101, 02, 16-19, 32, 33, 38-40, 200-202,) 225-233, 68216, 25, 26, 29-32, 35, 42-44, 47-51,) 53, 54, 56, 57
TT034F	2 Axle Tank Wagon	BP Oil Ltd	BPO 37068-79, 81, 82, 83
TT035A	2 Axle Tank Wagon	Brit Rail Traffic & Elect	BRT 57041-60
TT035B	2 Axle Tank Wagon	BP Oil Ltd and Shell (UK) Oil and Esso Petroleum) BPO 64180-87. SUKO 64130-33, 35-37, 39-41.) ESSO 64131, 2
TT035C	2 Axle Tank Wagon	BP Oil and Shell (UK) Oil	BPO 60174, 68369, 71. SUKO 68302, 08, 10.

2301/0585f/7

DIAGRAM	DESCRIPTION	OWNER	REGISTRATION NUMBERS
TT035D	2 Axle Tank Wagon	BP Oil & Shell (UK) Oil & Esso Petroleum) BPO 64160-76. ESSO 64104, 05, 07, 10, 13, 14.) SUKO 64100, 02, 04, 05, 07, 10, 14, 19, 22
TT035E	2 Axle Tank Wagon	BP Oil & Shell (UK) Oil & Esso Petroleum) BPO 66160-67, 70, 71. ESSO 66101, 05. SUKO 66102,) 05, 07, 08, 10, 12, 13, 15, 1, 17
TT035G	2 Axle Tank Wagon	BP Oil	BPO 37084, 98, 99
TT036A	2 Axle Tank Wagon	Charrington, Gardner, Lockett	CGL 53721-30
TT036B	2 Axle Tank Wagon	Charrington, Gardner, Lockett	CGL 53736-40, 62
TT037A	2 Axle Tank Wagon	Algeco & C.L.M.I.	ALG 49254-290, 365. CLMI 54000, 01, 02, 04-12
TT039B	2 Axle Tank Wagon	Storage & Trans Systems	STS 53112-28
TT039C	2 Axle Tank Wagon	Storage & Trans Systems	STS 53111
TT040A	2 Axle Tank Wagon	V.I.P. Petroleum	VIP 55201-44
TT040C	2 Axle Tank Wagon	Prococor	PR 58951, 2
TT041A	2 Axle Tank Wagon	Charrington, Gardner, Lockett	CGL 53763-7
TT042B	2 Axle Tank Wagon	Gulf Oil Ltd	GULF 54206-24
TT042F			
TT043A	2 Axle Tank Wagon	Algeco & C.L.M.I.	ALG 49104-253. CLMI 54033-64
TT043B	2 Axle Tank Wagon	Brit Rail Traffic & Elect	BRT 57142-53, 55-57, 59-80, 82-91
TT043C	2 Axle Tank Wagon	Brit Rail Traffic & Elect	BRT 57246-72, 74, 75, 77, 78, 80, 81, 83, 84, 86-94
TT043D	2 Axle Tank Wagon	Brit Rail Traffic & Elect	BRT 57245, 73, 76, 69, 82, 85
TT043E	2 Axle Tank Wagon	Brit Rail Traffic & Elect	BRT 57822-40
TT043F	2 Axle Tank Wagon	Esso Petroleum	ESSO 56000-103
TT043G	2 Axle Tank Wagon	Esso Petroleum	ESSO 56241-59, 61-81
TT043H	2 Axle Tank Wagon	Brit Rail Traffic & Elect	BRT 57547-50, 52, 55, 57
TT043J	2 Axle Tank Wagon	Brit Rail Traffic & Elect	BRT 57478, 479, 513, 516, 540, 541
TT043K	2 Axle Tank Wagon	Esso Petroleum	ESSO 56104-10, 12-99
TT043L	2 Axle Tank Wagon	Brit Rail Traffic & Elect) BRT 57484-496, 506-508, 510-512, 514, 515, 517-524,) 529-539, 542, 543, 559-565, 571-575

2301/0585f/8

DIAGRAM	DESCRIPTION	OWNER	REGISTRATION NUMBERS
TTO43M	2 Axle Tank Wagon	Algeco	ALG 49087-103
TTO43N	2 Axle Tank Wagon	Brit Rail Traffic & Elect	BRT 57154, 58, 81
TTO43P	2 Axle Tank Wagon	Brit Rail Traffic & Elect	BRT 57505, 09, 44
TTO44A	2 Axle Tank Wagon	Brit Rail Traffic & Elect) BRT 57382, 386, 387, 391-393, 396-399, 415, 417,) 418, 427, 428, 438, 439, 441-444, 447, 448, 454-457,) 470, 472, 473, 476
TTO44C	2 Axle Tank Wagon	Shell (UK) Oil	SUKO 61513-559, 600-637
TTO44D	2 Axle Tank Wagon	Shell (UK) Oil	SUKO 61638-659, 700-759, 800-858, 900-907
TTO44E	2 Axle Tank Wagon	Brit Rail Traffic & Elect	BRT 57394, 395, 400, 401, 402, 416, 419, 420, 445, 446, 449, 450
TTO45A	2 Axle Tank Wagon	Brit Rail Traffic & Elect	BRT 57192
TTO45B	2 Axle Tank Wagon	Brit Rail Traffic & Elect	BRT 57350-76
TTO45C	2 Axle Tank Wagon	Esso Petroleum	ESSO 56200-40
TTO45D	2 Axle Tank Wagon	Brit Rail Traffic & Elect	BRT 57670-94, 96
TTO45G	2 Axle Tank Wagon	Brit Rail Traffic & Elect	BRT 57350-76
TTO47A	2 Axle Tank Wagon	Tiger Railcar Leasing	TRL 51804-23
TTO48A	2 Axle Tank Wagon	Tiger Railcar Leasing	TRL 51824-34
TTO49A	2 Axle Tank Wagon	Procor	PR 58202, 04-11
TTO49B	2 Axle Tank Wagon	Procor	PR 58213-16, 18, 19, 20
TTO49C	2 Axle Tank Wagon	Procor	PR 58300-04, 06, 07
TTO49D	2 Axle Tank Wagon	Procor	PR 58308, 10, 12, 13
TTO49E	2 Axle Tank Wagon	Procor	PR 58681-684, 686-734, 736-780
TTO49F	2 Axle Tank Wagon	Procor	PR 58200, 01, 03, 12, 17, 21
TTO49G	2 Axle Tank Wagon	Procor	PR 58947-52
TTO49H	2 Axle Tank Wagon	Procor	PR 58953-5
TTO49J	2 Axle Tank Wagon	Procor	PR 58202, 06, 09, 10, 11
TTO49K	2 Axle Tank Wagon	Procor	PR 58213, 14, 15, 16, 18
TTO49L	2 Axle Tank Wagon	Procor	PR 58661-80
TTO49M	2 Axle Tank Wagon	Procor	PR 58681-780
TTO49U	2 Axle Tank Wagon	Procor	PR 58204, 5, 7, 8
TTO49V	2 Axle Tank Wagon	Procor	PR 58743, 61, 66

2301/0585f/9

DIAGRAM	DESCRIPTION	OWNER	REGISTRATION NUMBERS
TT051B	2 Axle Tank Wagon	Tiger Railcar Leasing	TRL 51561-85
TT051C	2 Axle Tank Wagon	Tiger Railcar Leasing	TRL 51649-677, 679-723
TT051D	2 Axle Tank Wagon	Tiger Railcar Leasing	TRL 51410-34
TT051H	2 Axle Tank Wagon	Tiger Railcar Leasing	TRL 51953
TT051J	2 Axle Tank Wagon	Tiger Railcar Leasing	TRL 51649-677, 679, 680, 682-720
TT051K	2 Axle Tank Wagon	Tiger Railcar Leasing	TRL 51562-75
TT052A	2 Axle Tank Wagon	Procor	PR 58410-424, 901-907, 909
TT052B	2 Axle Tank Wagon		
TT053A	2 Axle Tank Wagon	Procor) PR 58602-07, 09-11, 13-24, 26, 27, 29, 30, 32, 35,) 36, 38-42, 44, 46, 47, 49, 50 51, 53-58
TT053C	2 Axle Tank Wagon	Brit Rail Traffic & Elect	BRT 57478, 9
TT053D	2 Axle Tank Wagon	Brit Rail Traffic & Elect	BRT 57661
TT053E	2 Axle Tank Wagon	Procor	PR 58601, 08, 12
TT053G	2 Axle Tank Wagon	Procor	PR 57132, 3
TT053H	2 Axle Tank Wagon	Procor	PR 58625, 31, 33, 34, 37, 43, 48, 52, 59
TT054A	2 Axle Tank Wagon	Tiger Railcar Leasing	TRL 51895-914, 916-930, 936-947
TT055A	2 Axle Tank Wagon	Storage & Transp Systems	STS 53219-35
TT055C	2 Axle Tank Wagon	Storage & Transp Systems	STS 53237, 39-42, 47, 48
TT056A	2 Axle Tank Wagon	Procor	PR 58061-78
TT057A	2 Axle Tank Wagon	Procor	PR 58001-25
TT057B	2 Axle Tank Wagon	Procor	PR 58941-46
TT058A	2 Axle Tank Wagon	Shell (UK) Oil	SUKO 61908-54
TT058B	2 Axle Tank Wagon	BP Oil & Shell (UK) Oil	BPO 63160-99. SUKO 63100-10, 12-22, 24-42, 44-59, 65904, 67933
TT058C	2 Axle Tank Wagon	Shell (UK) Oil	SUKO 67258
TT058D	2 Axle Tank Wagon	Shell (UK) Oil	SUKO 65904
TT058E	2 Axle Tank Wagon	BP Oil	BPO 63161, 65, 70
TT058F	2 Axle Tank Wagon	Shell (UK) Oil	SUKO 61908-54

2301/0585f/10

DIAGRAM	DESCRIPTION	OWNER	REGISTRATION NUMBERS
TT059A	2 Axle Tank Wagon	BP Oil and Shell (UK) Oil	BPO 63260-93. SUKO 63200-08, 10, 12-22, 24-41, 43-50, 65905
TT059B	2 Axle Tank Wagon	BP Oil and Shell (UK) Ltd) BPO 63560, 563, 565, 567, 568, 571-574, 576, 578-580,) 582, 585-587, 589-593, 660-665, 667-670, 672, 673,) 675, 678-681, 683-686, 689-691, 693, 694, 698, 699,) 760, 762-764, 767, 770-772, 774-783, 785, 786, 788,) 789, 791-794, 860, 861, 863, 866-868, 870, 871,) 873-876, 878-880, 883-888, 890, 893-895. SUKO 63550,) 600-610, 612-616, 618-620, 622-629, 631-649, 651-659,) 700-704, 707-727, 729-750, 753, 755-759, 800-817,) 819-849, 852-856, 65800-849, 851-859, 906-911, 67932.
TT059C	2 Axle Tank Wagon	BP Oil	BPO 61582-599, 660-691
TT059D	2 Axle Tank Wagon	Shell (UK) Oil	SUKO 65800-849, 853-859, 905
TT059E	2 Axle Tank Wagon	Shell (UK) Oil	SUKO 63858
TT059G	2 Axle Tank Wagon	Shell (UK) Oil	SUKO 65906-11
TT059H	2 Axle Tank Wagon	Shell (UK) Oil	SUKO 63821-49, 52-56
TT059J	2 Axle Tank Wagon	Shell (UK) Oil	BPO 63578, 781
TT060A	2 Axle Tank Wagon	Shell (UK) Oil	SUKO 63858, 65900-03
TT060B	2 Axle Tank Wagon		
TT060D	2 Axle Tank Wagon		
TT060E	2 Axle Tank Wagon	Shell (UK) Oil	SULO 63858
TT060F	2 Axle Tank Wagon	BP Oil	BPO 63960
TT061A	2 Axle Tank Wagon	Brit Rail Traffic & Elect	BRT 57323, 24, 26, 27, 30, 33, 34, 36, 38, 39, 42, 44
TT061B	2 Axle Tank Wagon	Brit Rail Traffic & Elect	BTY 57325, 28, 29, 31, 32, 35, 37, 40, 41, 43
TT062A	2 Axle Tank Wagon	Brit Rail Traffic & Elect	BRT 57851-80

2301/0585f/11

DIAGRAM	DESCRIPTION	OWNER	REGISTRATION NUMBERS
TT063A	2 Axle Tank Wagon	BP Oil & Shell (UK) Oil	BPO 61560-81. SUKO 61500-12
TT064B	2 Axle Tank Wagon	E.G. Steele	STL 55056-78
TT065A	2 Axle Tank Wagon	Tiger Railcar Leasing	TRL 51724-63
TT066B	2 Axle Tank Wagon	BP Oil, Esso Petroleum and Shell (UK) Oil) BPO 64177-179, 697-699, 760-762. ESSO 64123-125,) 601, 607, 625, 628, 638, 640, 646, 719.) SUKO 64123-127, 129, 600, 601, 607, 609, 611, 617,) 619, 622, 625, 628, 630, 633, 637, 638, 640, 641,) 646, 647, 648, 654, 657, 658, 704, 705, 709,) 710, 714, 719, 721, 722, 723
TT066C	2 Axle Tank Wagon	BP Oil, Esso Petroleum and Shell (UK) Oil) BPO 64188-369. ESSO 64221, 22, 58. SUKP 64144, 146,) 149, 150, 152, 157, 158, 200, 202, 228, 205, 207,) 211, 212, 213, 217, 218, 219, 221, 222, 223, 226, 227,) 228, 230, 234, 235, 236, 238, 239, 241, 246, 250, 252,) 253, 254, 257, 258, 259, 303-306, 316
TT066D	2 Axle Tank Wagon	BP Oil, Esso Petroleum and Shell (UK) Ltd) BPO 64370-399, 460-499, 560-599, 660-683, 685-696.) ESSO 64326, 331, 335-337, 339-341, 350, 352, 353,) 404, 405, 407, 411, 416, 423, 425, 428-432, 443, 447,) 451, 453, 456, 507, 519, 520, 524, 528, 536, 540.) SUKO 64321, 325, 326, 330, 331, 335, 342, 345, 350,) 352, 353, 356, 404, 405, 407, 411, 416, 418, 419, 423,) 424, 425,, 428-432, 442-444, 447, 448, 451, 453, 455,) 456, 457, 507, 511, 513, 514, 515, 519, 520, 524,) 528-531, 536, 538, 540
TT066F	2 Axle Tank Wagon	Shell (UK) Oil	SUKO 61107
TT066G	2 Axle Tank Wagon	Shell (UK) Oil	SUKO 61222
TT066H	2 Axle Tank Wagon	Shell (UK) Oil	SUKO 62100-106, 108-159, 200-221, 223-239
TT066J	2 Axle Tank Wagon	BP Oil	BPO 63294

DIAGRAM	DESCRIPTION	OWNER	REGISTRATION NUMBERS
TT067B	2 Axle Tank Wagon	Storage & Transport Systems	STS 53318-21, 23-44
TT067C	2 Axle Tank Wagon	Storage & Transport Systems	STS 53300-12
TT067D	2 Axle Tank Wagon	Storage & Transport Systems	STS 53313-17, 22
TT068C	2 Axle Tank Wagon	Brit Rail Traffic & Elect	BRT 57194-201, 203-205, 207-224, 226, 227, 229-241, 243
TT068E	2 Axle Tank Wagon	Brit Rail Traffic & Elect	BRT 57588-590, 592, 593, 595-601, 603-631, 633-637
TT069C	2 Axle Tank Wagon	Brit Rail Traffic & Elect	BRT 57697-700, 702, 711, 613-737, 739-742, 744-746
TT070A	2 Axle Tank Wagon	Procor	PR 58400, 401, 403-405, 501-538, 540-550, 552-587, 589, 599
TT070B	2 Axle Tank Wagon	Brit Rail Traffic & Elect	BRT 57477
TT070C	2 Axle Tank Wagon	Brit Rail Traffic & Elect	BRT 57654
TT070D	2 Axle Tank Wagon	Brit Rail Traffic & Elect	BRT 57135
TT071A	2 Axle Tank Wagon	Storage & Transport Systems	STS 53129
TT071B	2 Axle Tank Wagon	Storage & Transport Systems	STS 53130
TT072A	2 Axle Tank Wagon	Tiger Railcar Leasing	TRL 51589-648
TT072B	2 Axle Tank Wagon		
TT073A	2 Axle Tank Wagon	Storage & Transport Systems	STS 53265-76
TT073B	2 Axle Tank Wagon	Storage & Transport Systems	STS 53277-83
TT075C	2 Axle Tank Wagon	Associated Octel	A0 55325-38
TT076A	2 Axle Tank Wagon	Brit Rail Traffic & Elect) BRT 57377-381, 383, 389, 403, 404, 406-408, 421-424,) 431, 433-437, 440, 452, 453, 458, 460, 461, 463-469,) 471-475, 566-570
TT076B	2 Axle Tank Wagon	Brit Rail Traffic & Elect	BRT 57405, 412, 413, 429, 430, 432, 462, 551, 553, 554, 556, 558
TT076C	2 Axle Tank Wagon	Brit Rail Traffic & Elect	BRT 57378, 379, 388, 421-424, 463, 466, 468, 469

2301/0585f/13

DIAGRAM	DESCRIPTION	OWNER	REGISTRATION NUMBERS
TT077A	2 Axle Tank Wagon	Railease	RLS 55500-9
TT077B	2 Axle Tank Wagon	Tiger Railcar Leasing	TRL 55510-19
TT078A	2 Axle Tank Wagon		
TT079A	2 Axle Tank Wagon	Algeco	ALG 49367-90
TT080A	2 Axle Tank Wagon	Storage & Transport Systems	STS 53092-106
TT081A	2 Axle Tank Wagon	Procor	PR 58908
TT083A	2 Axle Tank Wagon		
TT083B	2 Axle Tank Wagon		
TT083C	2 Axle Tank Wagon	BRT & E	BRTE 57440, 57464, 57467
TT084A	2 Axle Tank Wagon	Tiger Railcar Leasing	TRL 55520-25
TT087A	2 Axle Tank Wagon	Storage & Transport Systems	STS 53345-66
TT088A	2 Axle Tank Wagon	BP Oil	BPO 37272
TT088B	2 Axle Tank Wagon		
TT088C	2 Axle Tank Wagon		
TT088D	2 Axle Tank Wagon		
TT088E	2 Axle Tank Wagon	BP Oil	BPO 37094-097, 181-187
TT088F	2 Axle Tank Wagon	BP Oil	BPO 37085-093, 160-180
TT088G	2 Axle Tank Wagon	BP Oil	BPO 37060-63, 67983-99
TT088H	2 Axle Tank Wagon	BP Oil	BPO 37064-67
TT088K	2 Axle Tank Wagon	Shell (UK) Oil	SUKO 67000-059, 100-135
TT088L	2 Axle Tank Wagon	Shell (UK) Oil	SUKO 65712-42
TT088M	2 Axle Tank Wagon	Shell (UK) Oil	SUKO 65500-559, 600-605, 607-617
TT088N	2 Axle Tank Wagon	Shell (UK) Oil	SUKO 65618-659, 700-711
TT088P	2 Axle Tank Wagon	BP Oil	BPO 37188-195, 67262, 264, 266, 267, 272, 274, 285, 289, 361, 367, 369, 370, 371
TT088Q	2 Axle Tank Wagon	BP Oil	BPO 67374, 88
TT088R	2 Axle Tank Wagon	BP Oil	BPO 37373-77

2301/0585f/14

DIAGRAM	DESCRIPTION	OWNER	REGISTRATION NUMBERS
TT089A	2 Axle Tank Wagon	Associated Octel	AO 55319-55324
TT090B	2 Axle Tank Wagon	Associated Octel	AO 55339-55357
TU001A	2 Axle Tank Wagon	Procor	PR 70023-67
TU001B	2 Axle Tank Wagon	Procor	PR 70068-92
TU001C	2 Axle Tank Wagon	Procor	PR 70093
TU001D	2 Axle Tank Wagon	Procor	PR 70098-117
TU001E	2 Axle Tank Wagon	Procor	PR 70094-97
TU002A	2 Axle Tank Wagon	Procor	PR 70001-22
TU003A	2 Axle Tank Wagon	BP Oil and Shell (UK) Oil	BPO 73060. SUKO 73000
TU004A	2 Axle Tank Wagon	Brit Rail Traffic & Elect.	BRT 70500-23
TU005A	2 Axle Tank Wagon	Petrofina	FINA 70900-31
TU006A	2 Axle Tank Wagon	Shell (UK) Oil	SUKO 71500
TU006B	2 Axle Tank Wagon	Shell (UK) Oil	SUKO 71501-15
TU009A	2 Axle Tank Wagon	I.C.I. (Mond Div)	ICIM 70800-18
TU009B	2 Axle Tank Wagon	I.C.I. (Mond Div)	ICIM 70819
TU010A	2 Axle Tank Wagon	Procor	PR 70138-49
TU011A	2 Axle Tank Wagon	Procor	PR 70118-37
TU012A	2 Axle Tank Wagon	Algeco	ALG 70300-11
TU013A	2 Axle Tank Wagon	Tiger Railcar Leasing	TRL 70700-27
TU014A	2 Axle Tank Wagon	Tiger Railcar Leasing	TRL 70728-33
TU015A	2 Axle Tank Wagon	Procor	PR 70150-61

2301/0585f/15

DIAGRAM	DESCRIPTION	OWNER	REGISTRATION NUMBERS
TU016A	2 Axle Tank Wagon	Charrington Gardner Lockett	CGL 70400-7
TU017A	2 Axle Tank Wagon	Charrington Gardner Lockett	CGL 70408, 9
TU018A	2 Axle Tank Wagon	Procor	PR 70162-64, 65, 70
TU018B	2 Axle Tank Wagon	Procor	PR 70172-82
TU018C	2 Axle Tank Wagon	Tiger Railcar Leasing	TRL 70734-44
TU018D	2 Axle Tank Wagon	Tiger Railcar Leasing	TRL 70745-48
TU019A	2 Axle Tank Wagon	Tiger Railcar Leasing	TRL 70550
TU020A	2 Axle Tank Wagon	Carless Solvents	CSL 74000-29
TU021A	2 Axle Tank Wagon	Lanstar	LTD 74500-3

2301/0585f/16

41 tonnes G.L.W. TANK WAGON - LIQUEFIED PETROLEUM GAS

TTOOIA

EXCESS LENGTH	5	H	M	L	E
tonnes	41	41	21	21	
VB	16	16	10	10	
AB					
RA	5	5	1	1	
MAX SPEED	60	60	45	45	

TOPS CODE										
CARKND		AARKND			OPERATING PANEL No					
T	T	V	T	T	V	A	1	2	7	5

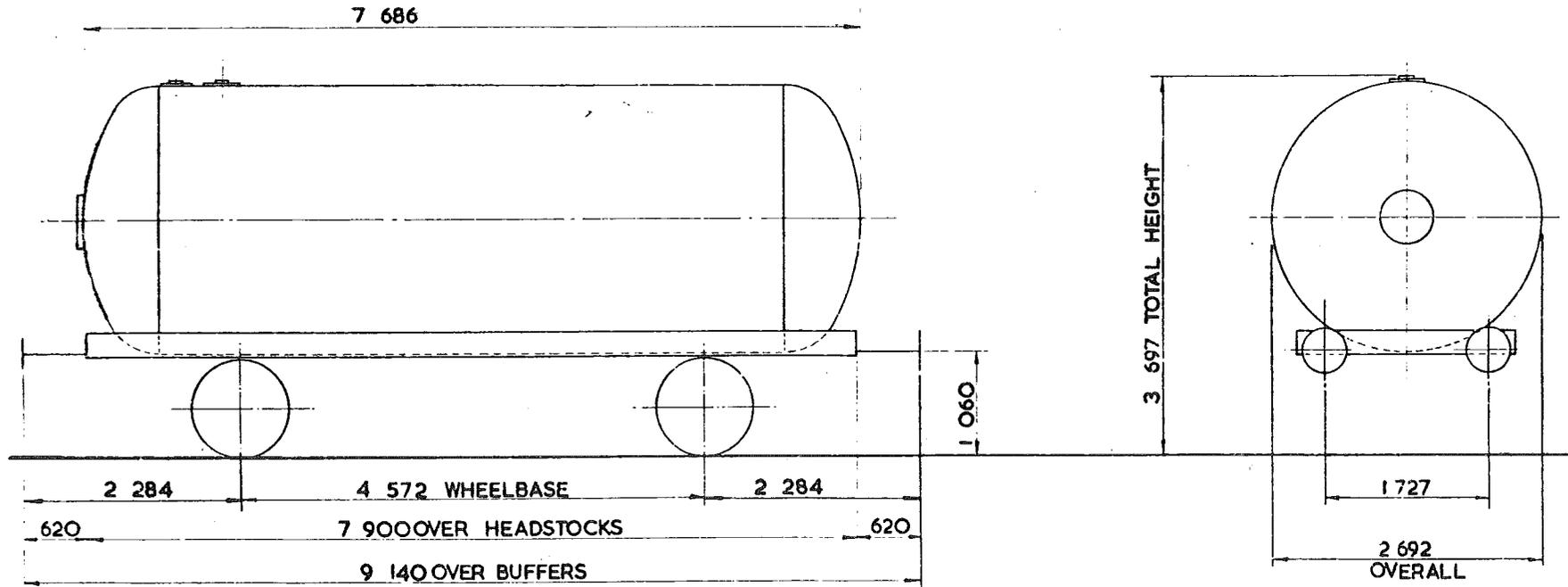

TARE - 18550 kg
CARRYING CAPACITY - 22400 kg
CAPACITY - 38641 litres
MAX. SPEED - 60 mile/h
WHEELS - 952 DIA.
JOURNALS - 140 DIA. ROLLER BEARINGS

BUFFERS - HYDRAULIC 406 DIA. HEADS
COUPLINGS - INTERNATIONAL SCREW
MIN. CURVE - 31 m
GEN. ARRGT DRG. No -
BRAKE - VACUUM BLOCK & HAND LEVER
SUSPENSION - DOUBLE LINK

BUILDER - METRO CAMELL
OWNER - ALGECO
REGISTERED BY - C.M.&E.E. (B.R.B.) DERBY
YEAR BUILT - 1966
REGISTRATION Nos. - 49291 TO 49316
OWNERS Nos. - 186719 TO 186747 (RANGE)

ISSUE 2

EX. P.O. DIAGRAM 6/133

41 tonnes GLW TANK WAGON - LIQUEFIED PETROLEUM GAS

TTOOIC

EXCESS LENGTH 4	H	M	L	E
tonnes	41	41	22	22
VB	20	20	12	12
AB				
RA	6	6	1	1
MAX SPEED	60	60	45	45

TOPS CODE										
CARKND		AARKND			OPERATING PANEL No					
T	T	V	T	T	V	A	I	4	2	O

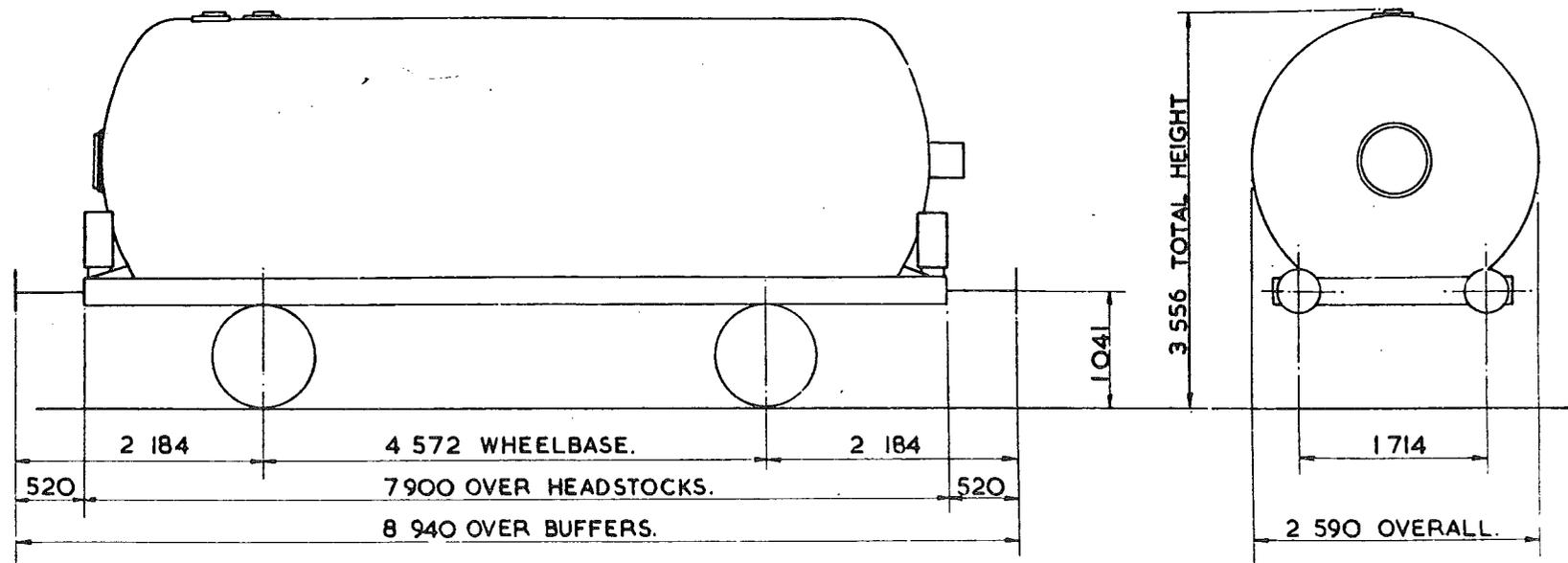

TAP	21300 kg
CARRYING CAPACITY	19700 kg
CAPACITY	-
MAX SPEED	60 mile/h.
WHEELS	952 DIA.
JOURNALS	140 DIA. ROLLER BEARINGS.

BUFFERS	HYDRAULIC 406 DIA. HEADS.
COUPLINGS	INSTANTER.
MIN. CURVE	31m.
GEN. ARRGT. DRG. No.	-
BRAKE	VACUUM BLOCK & HAND LEVER
SUSPENSION	EYEBOLT.

BUILDER	POWELL DUFFRYN.
OWNER	-
REGISTERED BY	C.M. & E.E. (B.R.B.) DERBY
YEAR BUILT	1963
REGISTRATION Nos.	SUKO 59113-53123
OWNERS Nos.	-

ISSUE 2
EX. PO. DIAGRAM 6/710 (ALLOCATED)

41 TONNES GLW LPG TANK WAGON

TT00IF

EXCESS LENGTH	4	H	M	L	E
tonnes	41	41	19	19	
-VB					
AB	17	17	10	10	
RA	6	6	1	1	
MAX SPEED	60	60	45	45	

TOPS CODE		
CARKND	AARKND	OPERATING PANEL No
T	T	A
A	A	I
4	2	2

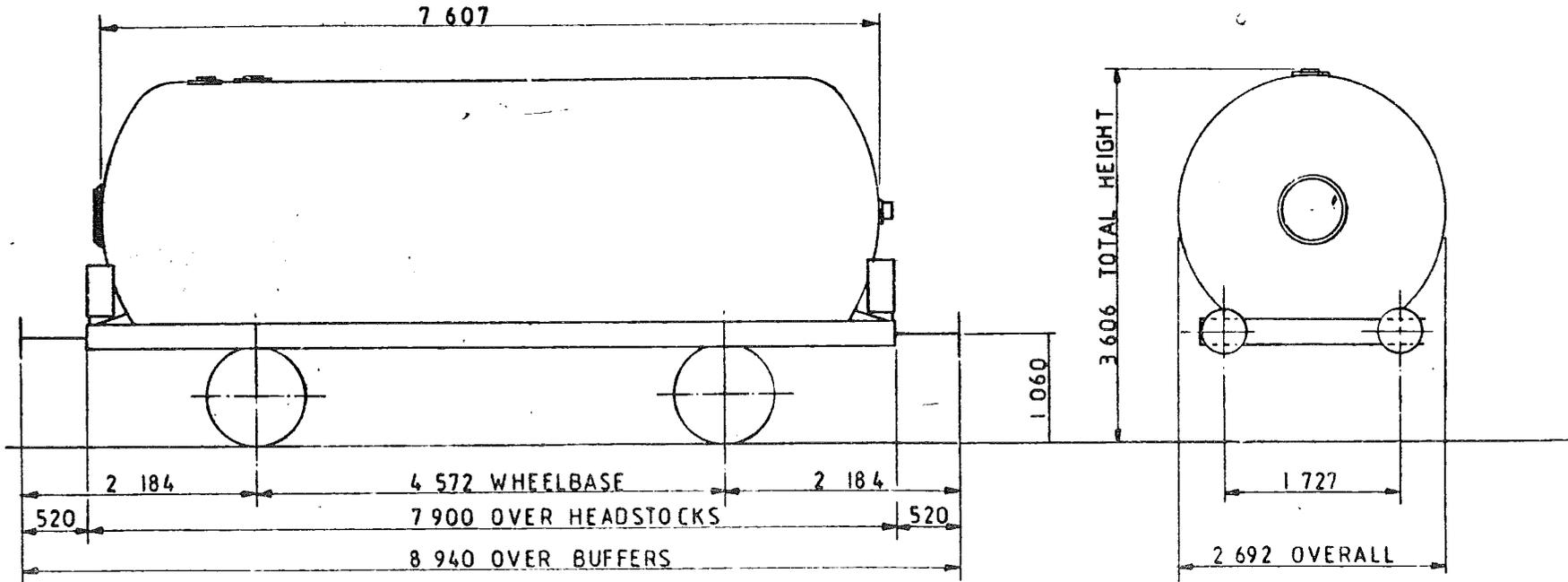

TARE - 19100 kg
CARRYING CAPACITY - 21900 kg
CAPACITY -
MAX SPEED 60 mile/h
WHEELS - 952 DIA
JOURNALS - 140 DIA ROLLER BEARINGS

BUFFERS HYDRAULIC 406 DIA HEADS
COUPLINGS INSTANTER
MIN. CURVE 31m
GEN ARRGT DRG No. -
BRAKE AIR BLOCK & HAND LEVER
SUSPENSION - DOUBLE LINK

ISSUE 1

EX. PO. DIAGRAM 6/711 (ALLOCATED)

41 TONNES GLW. LPG TANK WAGON

TTO0IG

EXCESS LENGTH	5	H	M	L	E
tonnes	41	41	21	21	
VB					
AB	25	25	12	12	
RA	5	5	1	1	
MAX SPEED	60	60	60	60	

TOPS CODE		
CARKND	AARKND	OPERATING PANEL No
T T A	T T A A	1 3 6 9

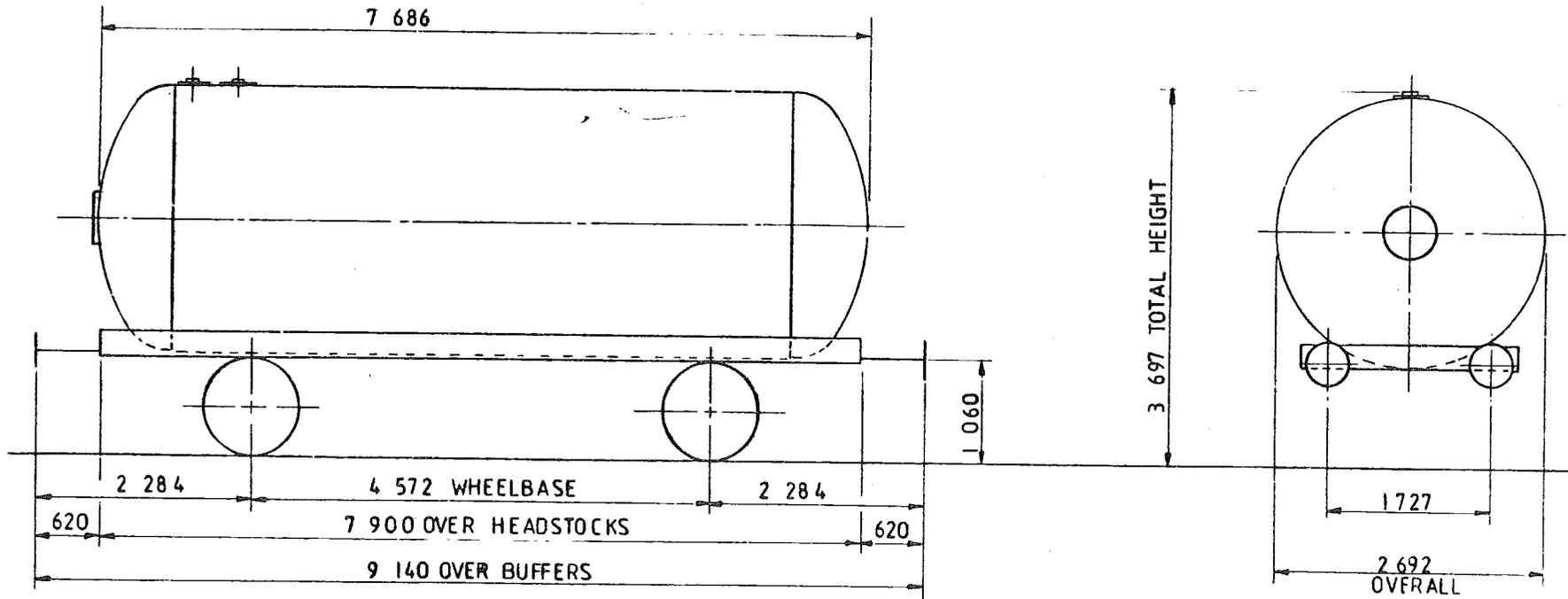

TARE - 18550 kg
CARRYING CAPACITY - 22400 kg
CAPACITY -
MAX SPEED - 60 mile/h
WHEELS - 952 DIA
JOURNALS - 140 DIA ROLLER BEARINGS

BUFFERS HYDRAULIC 406 DIA HEADS
COUPLINGS INTERNATIONAL SCREW
MIN. CURVE 31m
GEN ARRGT DRG No -
BRAKE - AIR BLOCK & HAND LEVER
SUSPENSION - DOUBLE LINK

ISSUE 1

41 TONNES GLW LPG TANK WAGON

TT00IH

EXCESS LENGTH	4	H	M	L	E
tonnes	41	41	22	22	
-VB					
AB	26	26	17	17	
RA	6	6	1	1	
MAX SPEED	60	60	60	60	

TOPS CODE		
CARKND	AARKND	OPERATING PANE
T	T	A
A	A	A
3	7	5

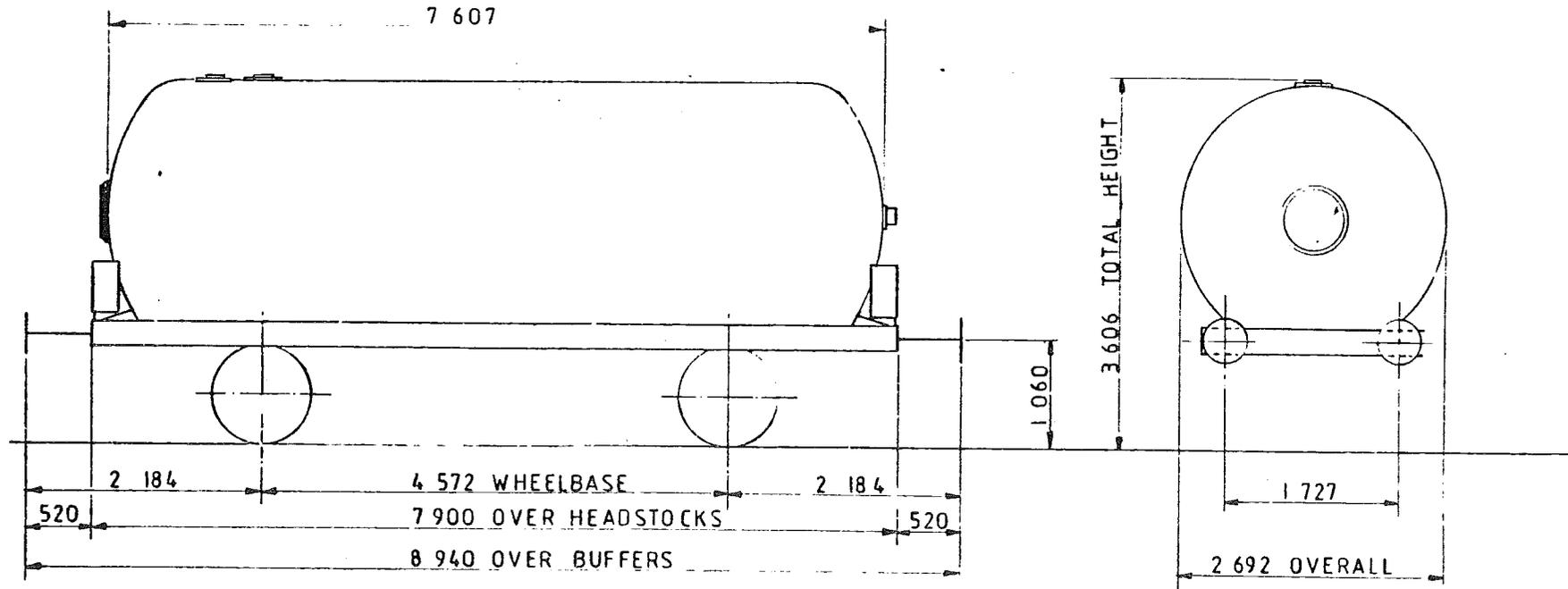

TARE - 21 650 kg
CARRYING CAPACITY - 19 300 kg
CAPACITY -
MAX SPEED 60 mile/h
WHEELS 952 DIA
JOURNALS 140 DIA ROLLER BEARINGS

BUFFERS HYDRAULIC 406 DIA HEADS
COUPLINGS INSTANTER
MIN CURVE 31m
GEN ARRGT DRG No
BRAKE AIR BLOCK & HAND LEVER
SUSPENSION GLOUCESTER FLOATING AXLE

ISSUE 1

EX. P.O. DIAGRAM 6/709 (ALLOCATED)

41 TONNES GLW LPG TANK WAGON

TT001J

EXCESS LENGTH	4	H	M	L	E
tonnes	41	41	22	22	
-VB					
AB	26	26	17	17	
RA	6	6	1	1	
MAX SPEED	60	60	60	60	

TOPS CODE				
CARKND	AARKND	OPERATING PANEL No		
T	T	A	A	1375

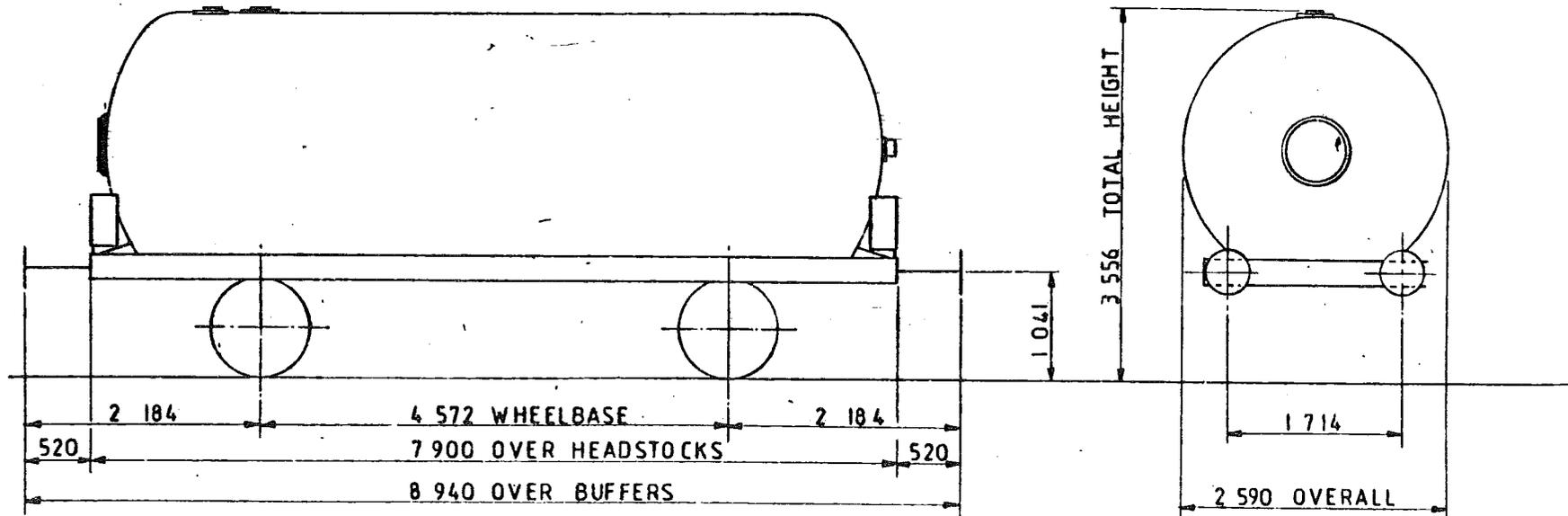

TARE - 21 300 kg
CARRYING CAPACITY - 19 700 kg
CAPACITY -
MAX SPEED - 60 mile/h
WHEELS - 952 DIA
JOURNALS - 140 DIA ROLLER BEARINGS

BUFFERS HYDRAULIC 406 DIA HEADS
COUPLINGS INSTANTER
MIN. CURVE 31m
GEN ARRGT. DRG No. -
BRAKE - AIR BLOCK & HAND LEVER
SUSPENSION - GLOUCESTER FLOATING AXLE

ISSUE 1

EX. RO. DIAGRAM 61710 (ALLOCATED)

41 TONNES GLW LPG TANK WAGON

TTOOIK

EXCESS LENGTH	A	H	M	L	E
tonnes	40	40	19	19	
-VB					
AB	25	25	12	12	
CA	6	6	1	1	
MAX SPEED	60	60	45	45	

TOPS CODE	
CARKND	AARKND
TTATTAIA1421	

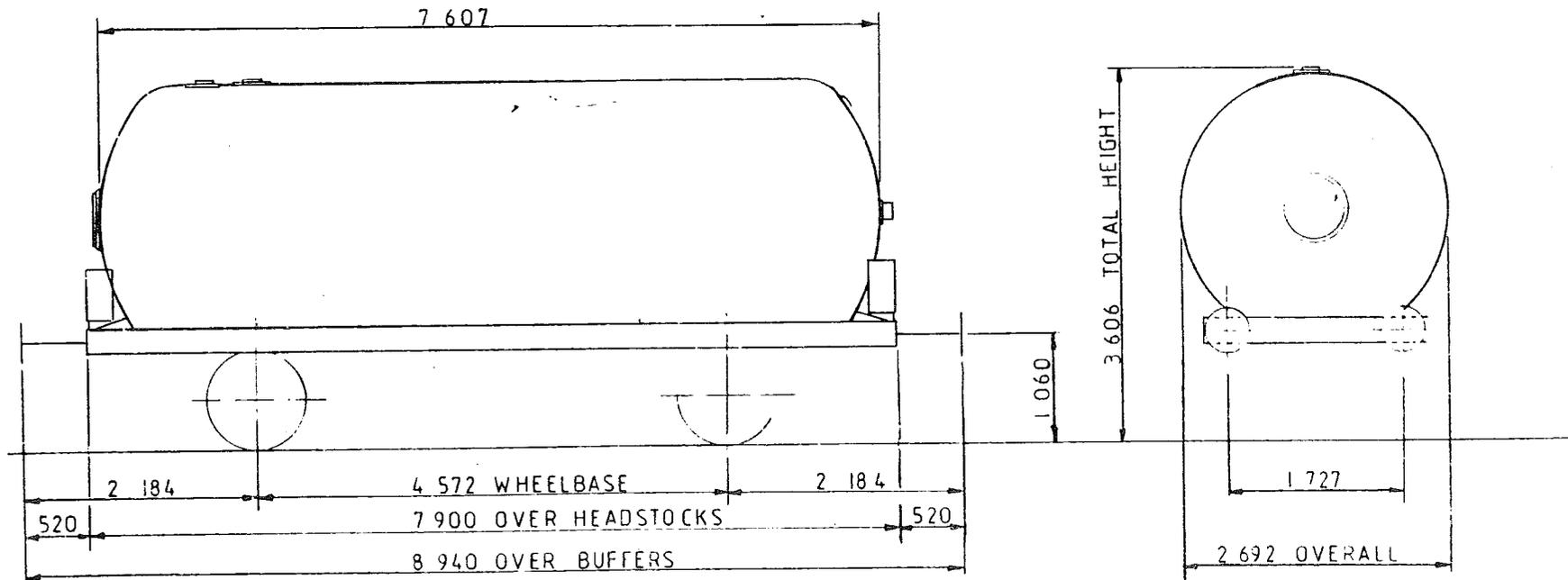

TARE	19,100 kg
CARRYING CAPACITY	21,930 kg
CAPACITY	-
MAX SPEED	60 mile/h
WHEELS	952 DIA
JOURNALS	140 DIA ROLLER BEARINGS

HEADS	HYDRAULIC 406 DIA HEADS
INSTANTER	INSTANTER
MAX SPEED	31m
GEN ARRGT DRG N.	
BRAKE	AIR BLOCK & HAND LEVER
SUSPENSION	DOUBLE LINK

ISSUE 1

41 tonne GLW TANK WAGON - L.P.G.

TT001L

EXCESS LENGTH	4	H	M	L	E
tonnes	41	41	22	22	
VB					
AB	20	20	12	12	
BA	6	6	1	1	
MAX SPEED	60	60	45	45	

TOPS CODE										
LARKND					AARKND					
T	T	A	T	T	A	A	1	4	7	6

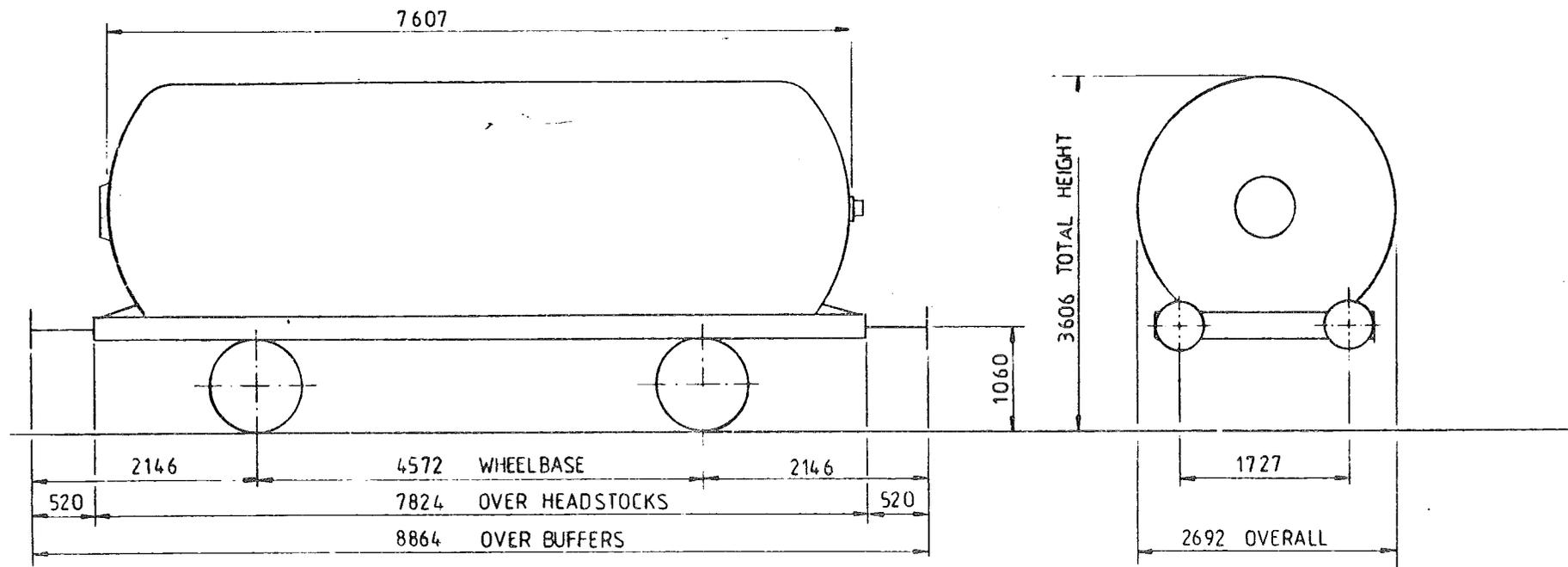

TARE	21700 kg
CARRYING CAPACITY -	19000 kg
CAPACITY -	Litres
MAX SPEED	60 mile/h
WHEELS	Ø 952
JOURNALS	Ø 140 ROLLER BEARINGS

BUFFERS	HYDRAULIC Ø 406 HEADS
COUPLINGS	INSTANTER
MIN CURVE	31m
GEN ARRGT DRG No	
BRAKE	AIR BLOCK, HAND LEVER
SUSPENSION	DOUBLE LINK

ISSUE 1

EX PO DIAGRAM 61709

46 tonnes GLW. TANK WAGON

TT001M

EXCESS LENGTH	4	H	M	L	E
tonnes	46	46	22	22	
VB					
AB	22	22	9	9	
RA	8	8	1	1	
MAX SPEED	60	60	45	45	

TOPS CODE										
CARKND		AARKND			OPERATING PANEL No					
T	T	A	T	T	A	A	1	6	1	0

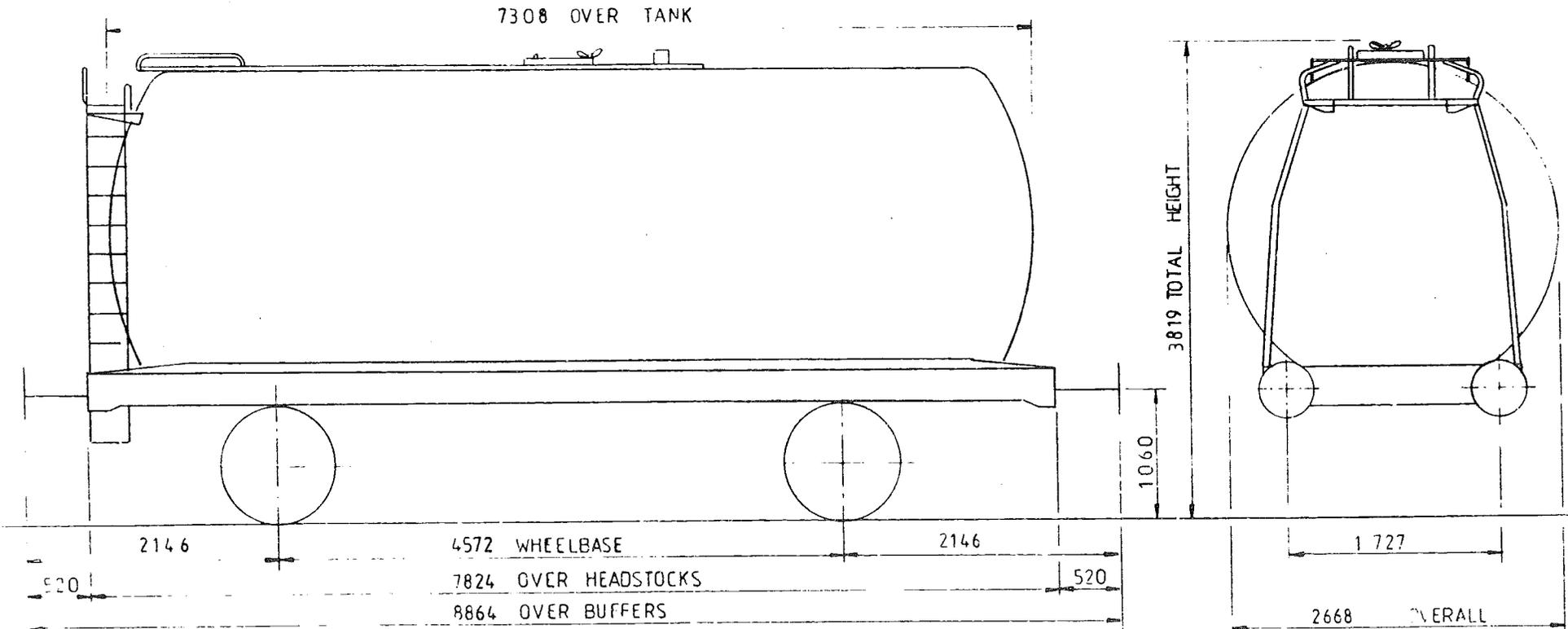

TARE	22 700 kg
CARRYING CAPACITY	23 300 kg
CAPACITY -	35713 Litres
MAX SPEED	60 mile/h
WHEELS	φ 952
JOURNALS	φ140 ROLLER BEARINGS

BUFFERS	HYDRAULIC φ406 HEADS
COUPLINGS	INSTANTER
MIN CURVE	39 m
GEN ARRGT DRG No	
BRAKE	AIR BLOCK HAND LEVER
SUSPENSION	DOUBLE LINK

ISSUE 1

EX PO DIAGRAM 6/184

46 tonnes G.L.W. TANK WAGON

TT001N

EXCESS LENGTH L	H	M	L	E
tonnes	46	46	22	22
VB	0	0	0	0
AB	22	22	9	9
RA	8	8	1	1
MAX SPEED	60	60	45	45

TOPS CODE										
CARKND			AARKND			OPERATING PANEL 110				
T	T	B	T	T	B	A	1	6	1	1

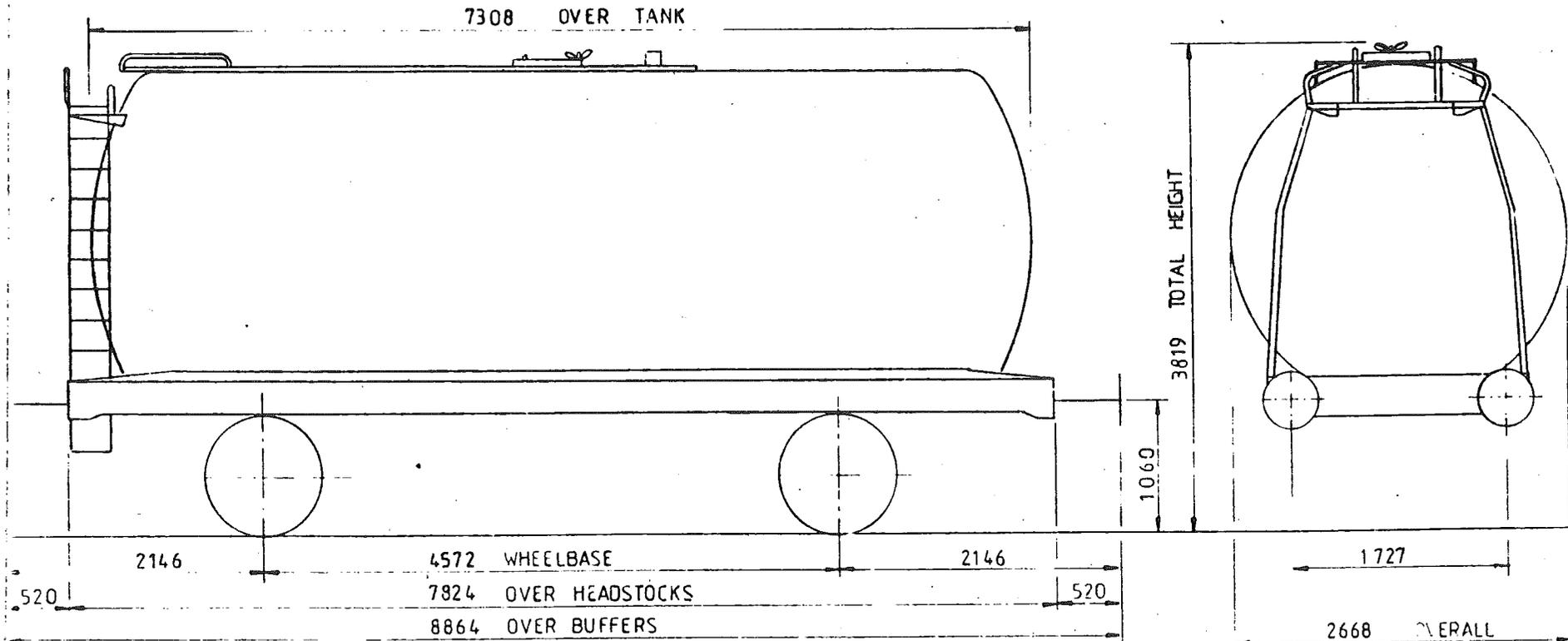

TARE	22 600 kg
CARRYING CAPACITY	23 400 kg
CAPACITY -	35 713 Litres
MAX SPEED	60 mile/h
WHEELS	φ 952
JOURNALS	φ140 ROLLER BEARINGS

BUFFERS	HYDRAULIC φ406 HEADS
COUPLINGS	INSTANTER
MIN CURVE	39 m
GEN ARRGT DRG No	
BRAKE	AIR BLOCK, VAC PIPE, HAND LEVER.
SUSPENSION	DOUBLE LINK

ISSUE 1

EX PO DIAGRAM 6/317

41 tonne GLW TANK WAGON

TT001P

EXCESS LENGTH	4	H	M	L	E
tonnes	41	41	19	19	
VB					
AB	25	25	12	12	
RA	6	6	1	1	
MAX SPEED	60	60	45	45	

TOPS CODE			
CARKND	AARKND	TANKS PARTS	
T	T	A	1 6 1 4

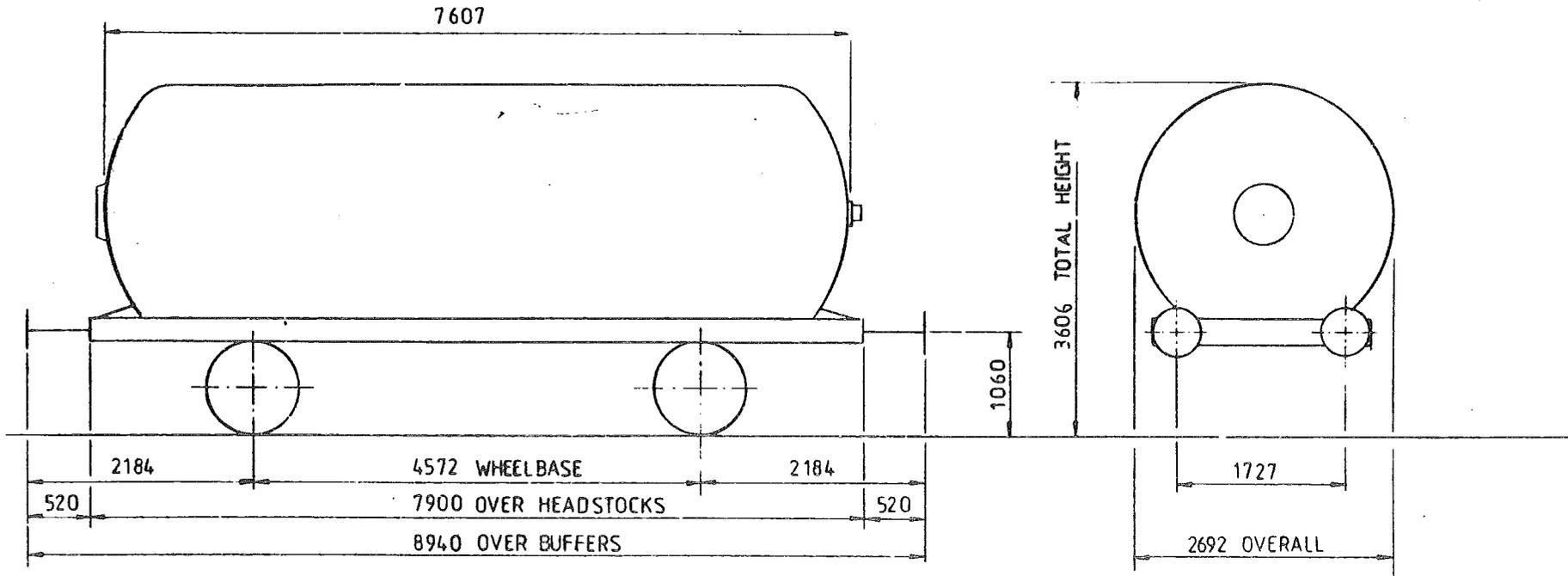

TARE	19 100	kg
CARRYING CAPACITY -	21 900	kg
CAPACITY -		Litres
MAX SPEED	60	mile/h
WHEELS	φ 952	
JOURNALS	φ 140	ROLLER BEARINGS

BUFFERS	HYDRAULIC	φ 406	HEADS
COUPLINGS	INSTANTER		
MIN CURVE	31m		
GEN ARRGT DRG No			
BRAKE	AIR BLOCK,	HAND LEVER	
SUSPENSION	FAT. 26		

ISSUE 1

EX PO. DIAGRAM 6 / 711

41 tonne GLW TANK WAGON

TT001Q

EXCESS LENGTH	4	H	M	L	E
tonnes	41	41	19	19	
VB					
AB	25	25	12	12	
RA	6	6	1	1	
MAX SPEED	60	60	45	45	

TOPS CODE					
CARKND	AARKND	OPERATION	PANEL		
T	T	A	T	A	A
		1	6	3	2

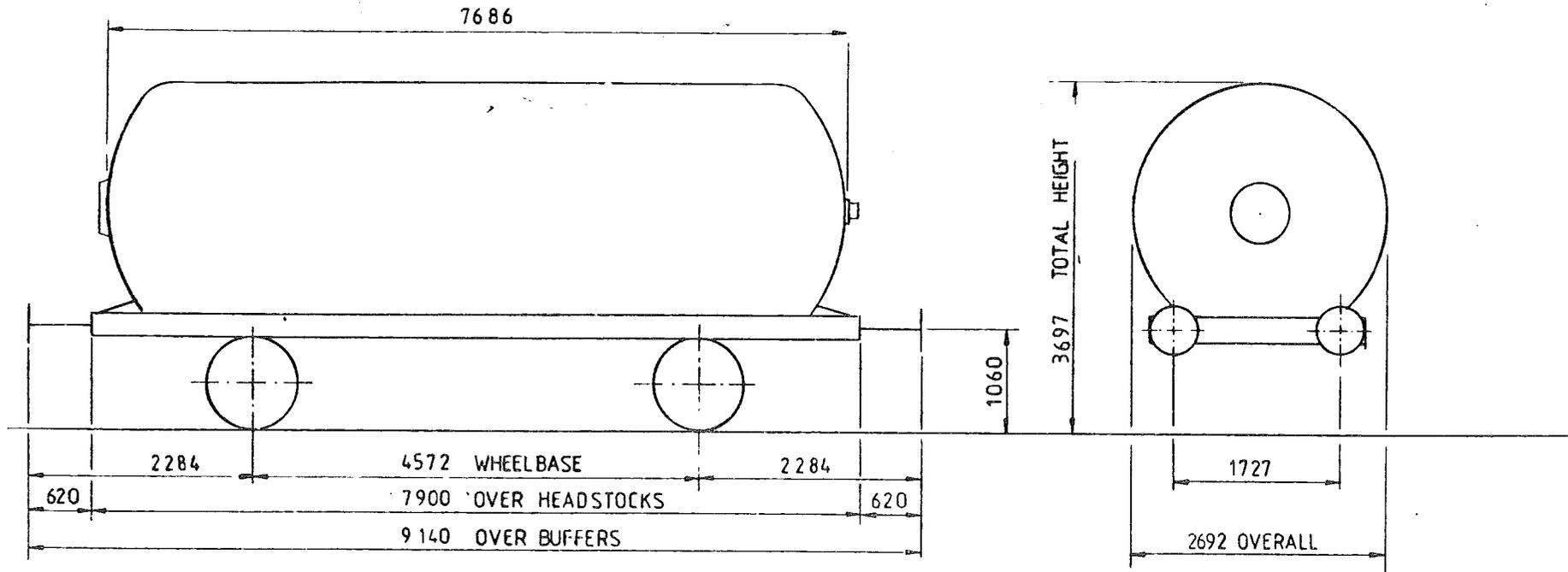

TARE	18550 kg
CARRYING CAPACITY -	22400 kg
CAPACITY -	Litres
MAX SPEED	60 mile/h
WHEELS	φ 952
JOURNALS	φ 140 ROLLER BEARINGS

BUFFERS	HYDRAULIC φ 406 HEADS
COUPLINGS	INTERNATIONAL SCREW
MIN CURVE	31m
GEN ARRGT DRG No	
BRAKE	AIR BLOCK, HAND LEVER
SUSPENSION	F.A.T. 26.

ISSUE 1

EX PO. DIAGRAM 6 / 133

41 tonne GLW TANK WAGON

LOT NUMBER	

TOPS INFORMATION						
AARKND	OPERATING	OPERATING SPEED		BRAKE FORCE DATA		EXCESS
CARKND	PANEL No.	60 mile/h UP TO	41 tonne GLW	9t FORCE UP TO	25 tonne GLW	LENGTH
T T A A		mile/h ABOVE		22t FORCE ABOVE		4
						RA (GLW)
						8
						DESIGN SHEET
						W1017

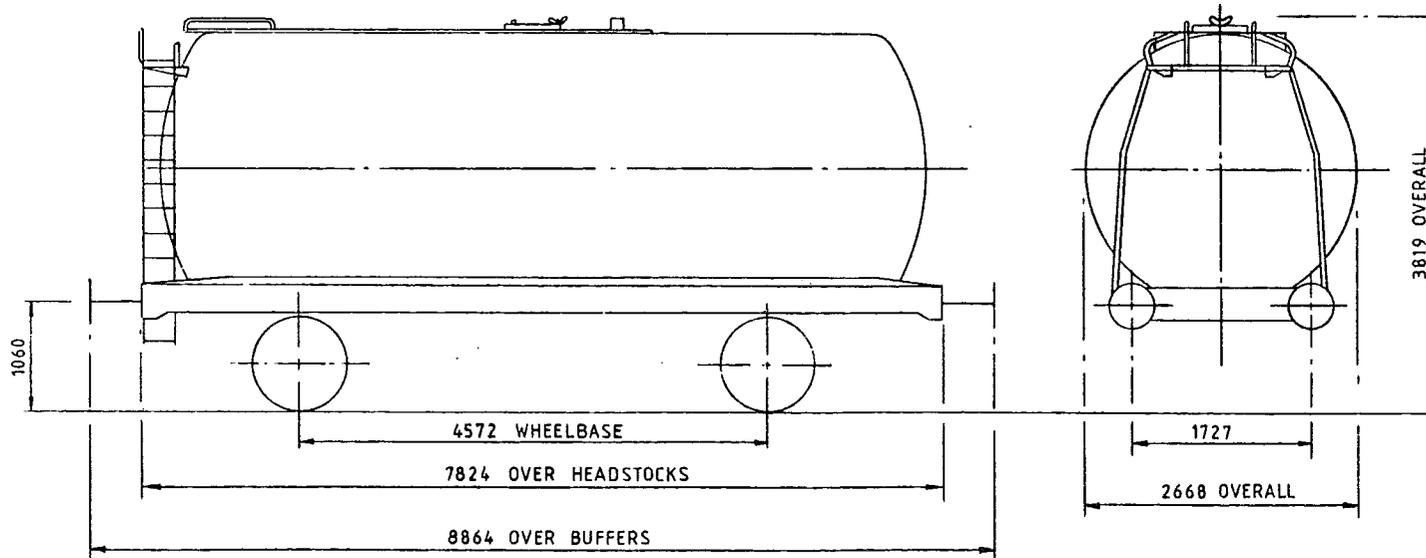

TARE-	21.600 Kg
CAPACITY, WEIGHT-	19.400 Kg
CAPACITY, VOLUME-	35.713 litres
MIN. CURVE-	31m
GEN. ARRGT. DRG. NO.-	

BRAKE-	AIR BLOCK & HAND LEVER
SUSPENSION-	FAT 26
COUPLINGS-	INSTANTER
BUFFERS-	HYDRAULIC 406 DIA HEADS
WHEELS-	952 DIA
JOURNALS-	140 DIA ROLLER BEARINGS

ISSUE 1

41 tonne GLW L.P.G. TANK WAGON

LOT NUMBER	

TOPS INFORMATION											
AARKND	OPERATING			OPERATING SPEED		BRAKE FORCE DATA			EXCESS LENGTH	RA (GLW)	DESIGN SHEET
CARKND	PANEL No.			60 mile/h UP TO	41 tonne GLW	12 t FORCE UP TO	25 tonne GLW		4	7	W1116
T T A A				mile/h ABOVE		25 t FORCE ABOVE					

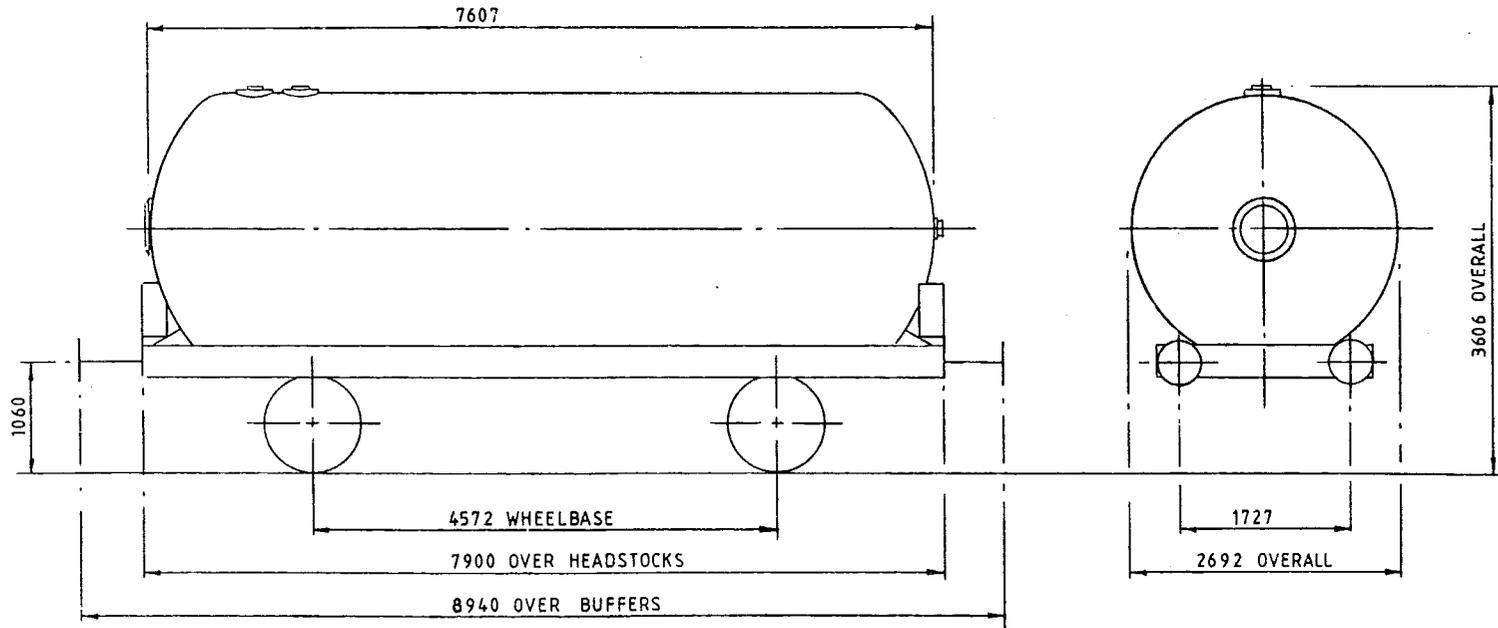

TARE-	18.750 Kg
CAPACITY, WEIGHT-	22.250 Kg
CAPACITY, VOLUME-	
MIN. CURVE-	31m
GEN. ARRGT. DRG. NO.-	

BRAKE-	AIR BLOCK & HAND LEVER
SUSPENSION-	DOUBLE LINK & PARABOLIC SPRING
COUPLINGS-	INSTANTER
BUFFERS-	HYDRAULIC 406 DIA HEADS
WHEELS-	952 DIA
JOURNALS-	140 DIA ROLLER BEARINGS

ISSUE 1

46tonne GLW L.P.G. TANK WAGON

LOT NUMBER	

TOPS INFORMATION						
AARKND	OPERATING	OPERATING SPEED		BRAKE FORCE DATA		EXCESS LENGTH
CARKND	PANEL No.	60 mile/h UP TO	46 tonne GLW	6 t FORCE UP TO	30.5 tonne GLW	5
T T A A		mile/h ABOVE		25 t FORCE ABOVE		8
						DESIGN SHEET W1465

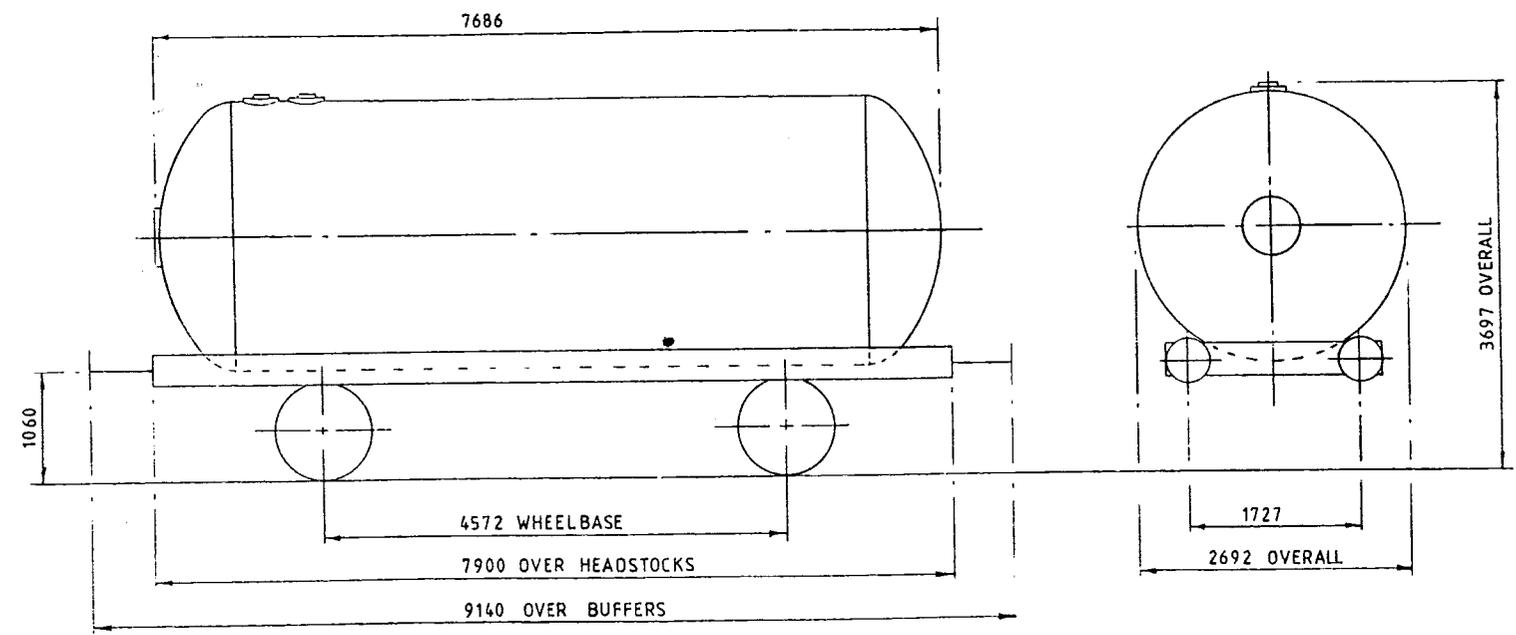

TARE-	18.500 Kg
CAPACITY, WEIGHT-	27220 Kg
CAPACITY, VOLUME-	38.641 litres
MIN. CURVE-	31m
GEN. ARRGT. DRG. NO.-	

BRAKE-	AIR BLOCK & HAND LEVER
SUSPENSION-	SINGLE LINK & PARABOLIC SPRING
COUPLINGS-	INTERNATIONAL SCREW
BUFFERS-	HYDRAULIC 406 DIA HEADS
WHEELS-	952 DIA
JOURNALS-	140 DIA ROLLER BEARINGS

ISSUE 1

41 tonne GLW L.P.G. TANK WAGON

TT002D

EXCESS LENGTH	4	H	M	L	E
tonnes	41	41	19	19	
VB					
AB	25	25	12	12	
CA	6	6	1	1	
MAX SPEED	60	60	45	45	

TOPS CODE	
CARKND	AARKND
T T A T T A A 1 5 1 3	

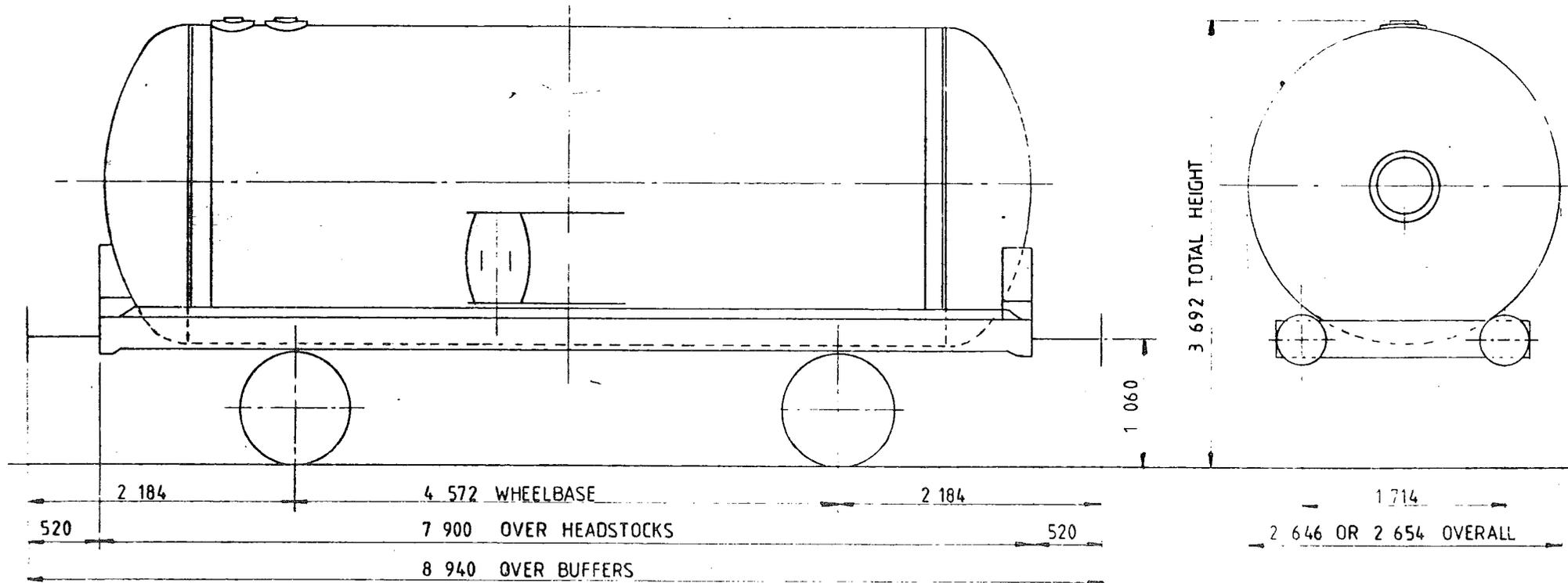

TARE	19 200 kg
CARRYING CAPACITY	21 800 kg
CAPACITY	
MAX SPEED	60 mile/h
WHEELS	952 DIA
JOURNALS	140 DIA ROLLER BEARINGS

BUFFER	HYDRAULIC 406 DIA HEADS
COPPLERS	INSTANTER
MIN CURVE	31m SINGLY & CLOSE COUPLED
GEN ARRGT DRG No	
BRAKE	AIR BLOCK, HAND LEVER
SUSPENSION	DOUBLE LINK

ISSUE 1

41 tonne G.L.W L.P.G. TANK WAGON

TT002E

EXCESS LENGTH	H	M	L	E
tonnes	41	41	19	19
AB				
AB	25	25	12	12
A	6	6	1	1
MAX SPEED	60	60	45	45

TOPS CODE		
MARKND	AARKND	REMARKS
T T A	T T A A	1 5 1 3

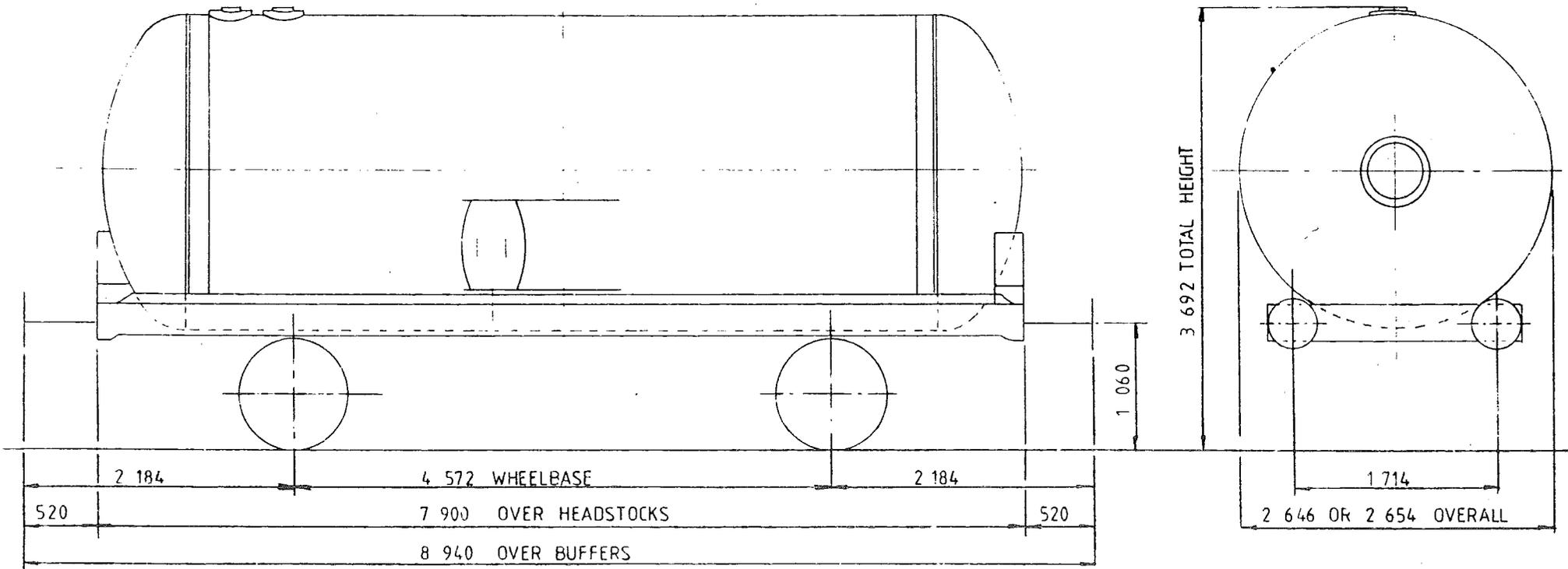

TARE	18 900 kg
CARRYING CAPACITY	22 100 kg
CAPACITY	-
MAX SPEED	60 mile/h
WHEELS	952 DIA
JOURNALS	140 DIA ROLLER BEARINGS

BUFFERS	HYDRAULIC 406 DIA HEADS
COUPLINGS	INSTANTER
MIN CURVE	31m SINGLY & CLOSE COUPLED
GEN ARRGT DRG No	-
BRAKE	AIR BLOCK, HAND LEVER
SUSPENSION	DOUBLE LINK

ISSUE 1

EX P.O. DIAGRAM 6/713 (ALLOCATED)

41 tonne GLW L.P.G. TANK WAGON

TT002H

EXCESS LENGTH 4	H	M	L	E
tonnes	41	41	19	19
VB				
AB	25	25	12	12
BA	6	6	1	1
MAX SPEED	60	60	45	45

TOPS CODE										
CARKND		AARKND			OPERATING PANEL No					
T	T	A	T	T	A	A	1	4	2	1

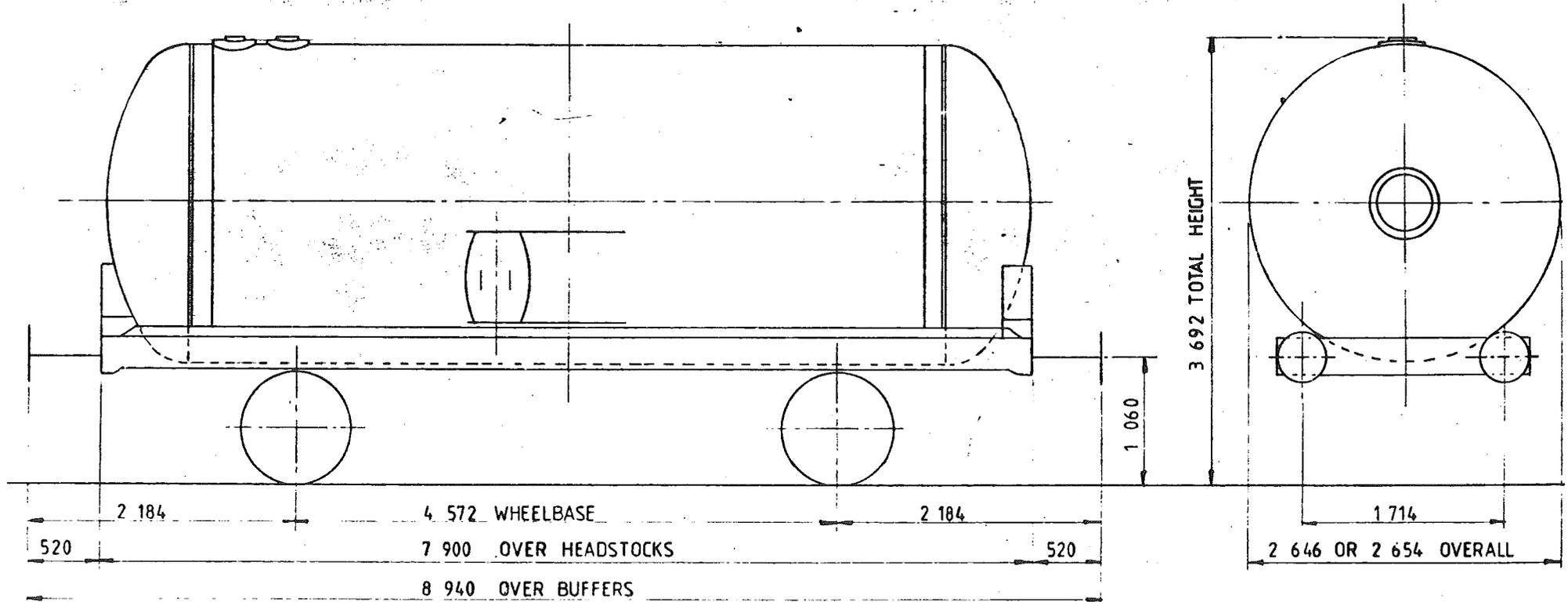

TARE	18,500 kg
CARRYING CAPACITY -	22,100 kg
CAPACITY -	
MAX SPEED	60 mile/h
WHEELS	952 DIA
JOURNALS	140 DIA ROLLER BEARINGS

BUFFER	HYDRAULIC 406 DIA HEADS
COUPLERS	INSTANTER
MIN CURVE	31m SINGLY & CLOSE COUPLED
GEN ARRGT DRG No	
BRAKE	AIR BLOCK, HAND LEVER
SUSPENSION	DOUBLE LINK

ISSUE 1

41 tonne G.L.W L.P.G. TANK WAGON

TT002J

EXCESS LENGTH 4	H	M	L	E
tonnes	41	41	19	19
AB				
AB	25	25	12	12
RA	6	6	1	1
MAX SPEED	60	60	45	45

TOPS CODE		
CARKND	AARKND	
T T A	T T A A	1 4 2 1

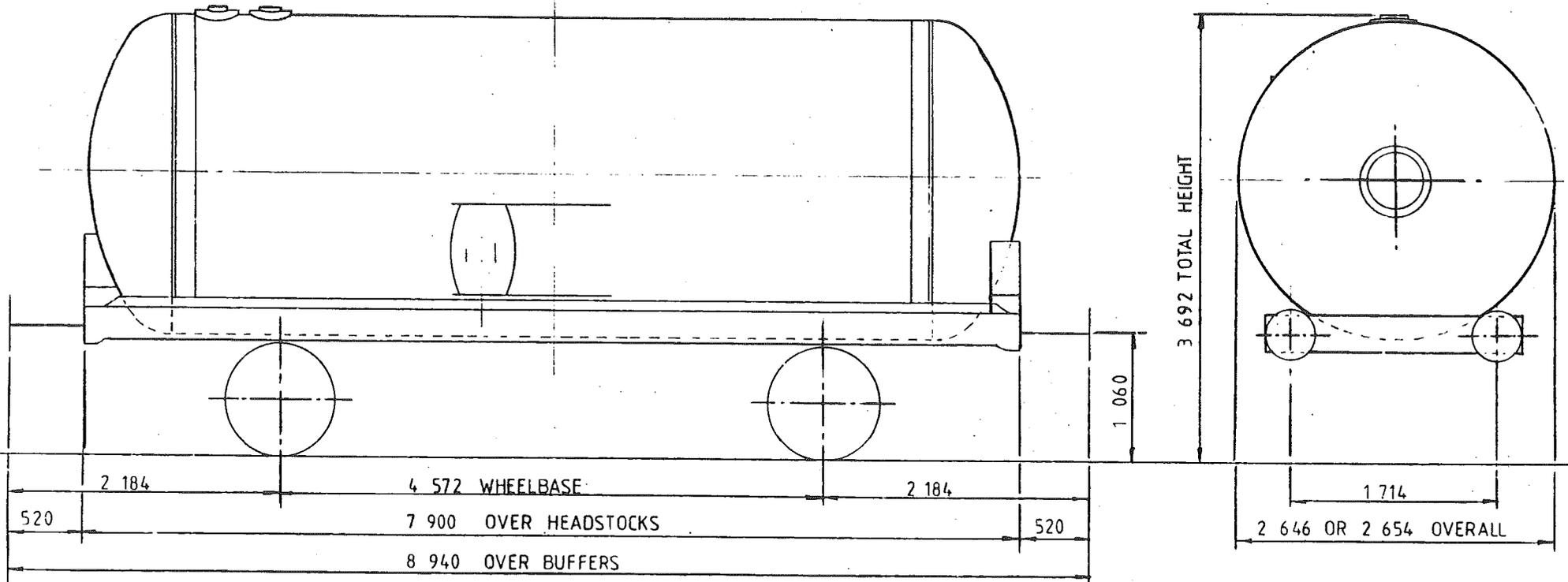

TARE - 18 550 kg
CARRYING CAPACITY - 22 400 kg
CAPACITY -
MAX SPEED - 60 mile/h
WHEELS - 952 DIA
JOURNALS - 140 DIA ROLLER BEARINGS

BUFFERS - HYDRAULIC 406 DIA HEADS
COUPLINGS - INSTANTER
MIN CURVE - 31m SINGLY & CLOSE COUPLED
GEN ARRG T DRG No
BRAKE - AIR BLOCK, HAND LEVER
SUSPENSION - DOUBLE LINK

ISSUE 1

41 tonne GLW TANK WAGON

TT002K

EXCESS LENGTH	4	H	M	L	E
tonnes	41	41	19	19	
VB					
AB	25	25	12	12	
RA	6	6	1	1	
MAX SPEED	60	60	60	60	

TOPS CODE		
CARKND	AARKND	COMPASS PART NO.
T T A	T T A A	1 6 1 4

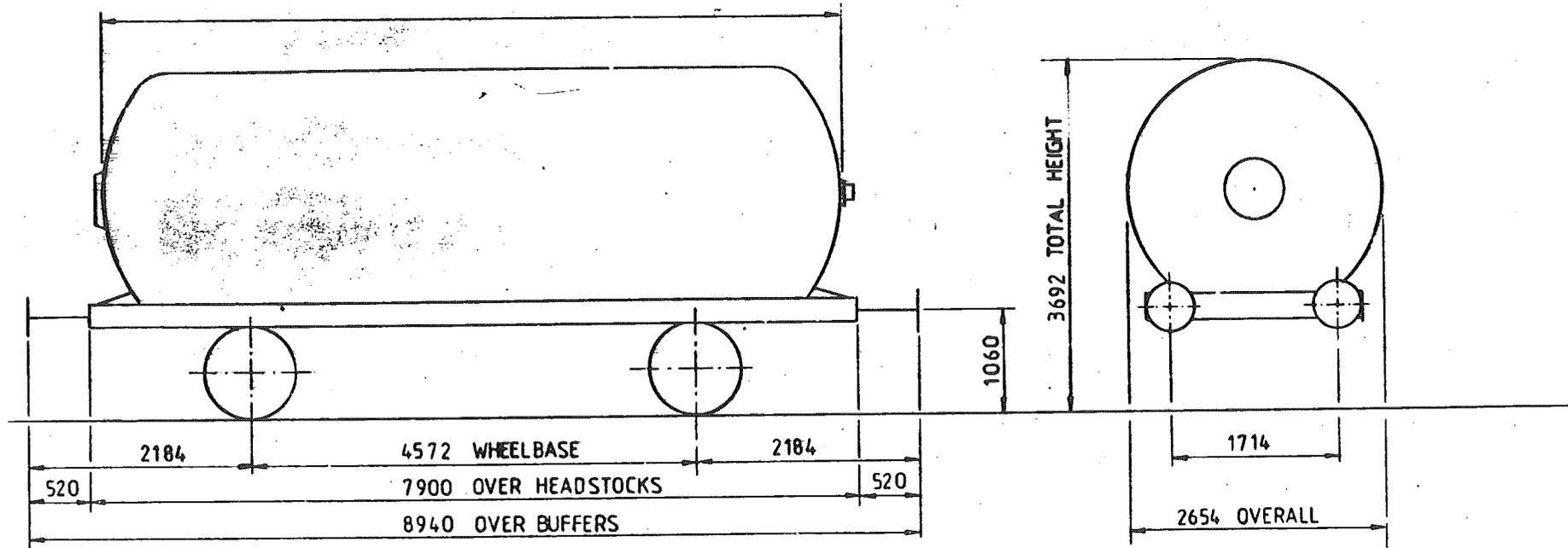

TARE	19 200 kg
CARRYING CAPACITY -	22 800 kg
CAPACITY -	Litres
MAX SPEED	60 mile/h
WHEELS	Ø 952
JOURNALS	Ø 140 ROLLER BEARINGS

BUFFERS	HYDRAULIC Ø 406 HEADS
COUPLINGS	INSTANTER
MIN CURVE	31m
GEN ARRGT DRG No	
BRAKE	AIR BLOCK, HAND LEVER
SUSPENSION	FAT 26

ISSUE 1

EX PO. DIAGRAM 61712

41 tonne GLW TANK WAGON

TT002L

EXCESS LENGTH	4	H	M	L	E
tonnes	41	41	19	19	
VB					
AB	25	25	12	12	
RA	8	8	1	1	
MAX SPEED	60	60	60	60	

TOPS CODE										
CARKND			AARKND			OPERATION PANEL				
T	T	A	T	T	A	A	1	6	1	4

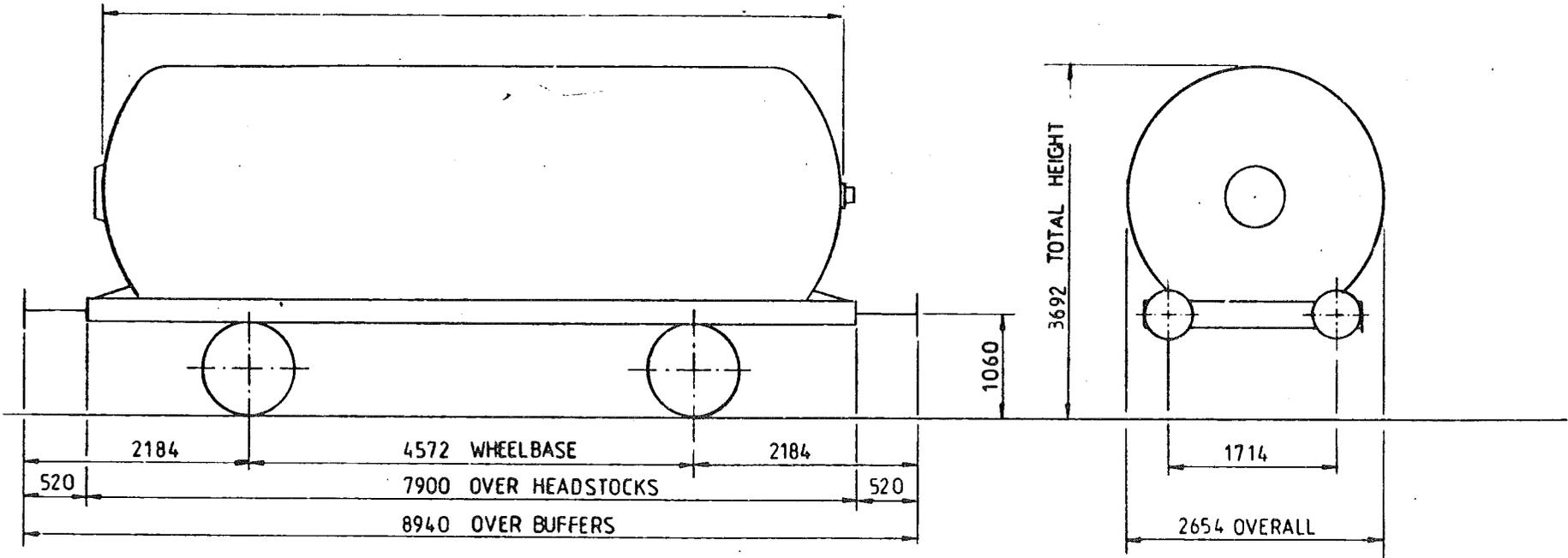

TARE	18 900 kg
CARRYING CAPACITY -	22 100 kg
CAPACITY -	Litres
MAX SPEED	60 mile/h
WHEELS	Ø 952
JOURNALS	Ø 140 ROLLER BEARINGS

BUFFERS	HYDRAULIC Ø 406 HEADS
COUPLINGS	INSTANTER
MIN CURVE	31m
GEN ARRGT DRG No	
BRAKE	AIR BLOCK, HAND LEVER
SUSPENSION	DOUBLE LINK & PARABOLIC TAPERLEAF SPRINGS

ISSUE 1

EX PO DIAGRAM 6/713

41 tonne GLW TANK WAGON

TT002M

EXCESS LENGTH	4	H	M	L	E
tonnes	41	41	19	19	
VB					
AB	25	25	12	12	
RA	8	8	1	1	
MAX SPEED	60	60	60	60	

TOPS CODE										
CARKND		AARKND			OPERATION					
T	T	A	T	T	A	A	1	6	4	0

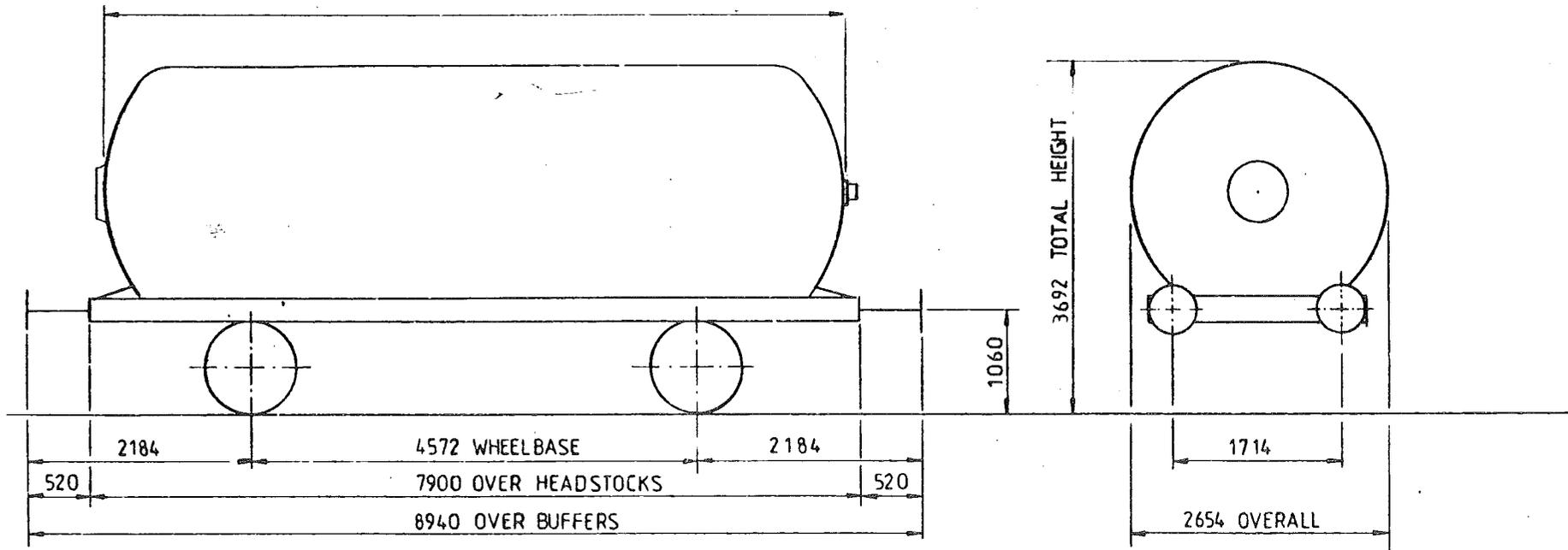

TARE	18 ⁵⁵⁰ kg
CARRYING CAPACITY -	22 ⁴⁰⁰ kg
CAPACITY -	Litres
MAX SPEED	60 mile/h
WHEELS	φ 952
JOURNALS	φ 140 ROLLER BEARINGS

BUFFERS	HYDRAULIC φ 406 HEADS
COUPLINGS	INSTANTER
MIN CURVE	31m
GEN ARRGT DRG No	
BRAKE	AIR BLOCK, HAND LEVER
SUSPENSION	DOUBLE LINK AND PARABOLIC TAPERLEAF SPRINGS

ISSUE 1

EX PO. DIAGRAM 6/130

41 tonne GLW L.P.G. TANK WAGON

DIAGRAM T T002N

LOT NUMBER	

TOPS INFORMATION						
AARKND	OPERATING	OPERATING SPEED		BRAKE FORCE DATA		EXCESS LENGTH
CARKND	PANEL No.	60 mile/h UP TO	41 tonne GLW	12t FORCE UP TO	28 tonne GLW	RA (GLW)
T T A A		mile/h ABOVE		25t FORCE ABOVE		4
						7
						W1117

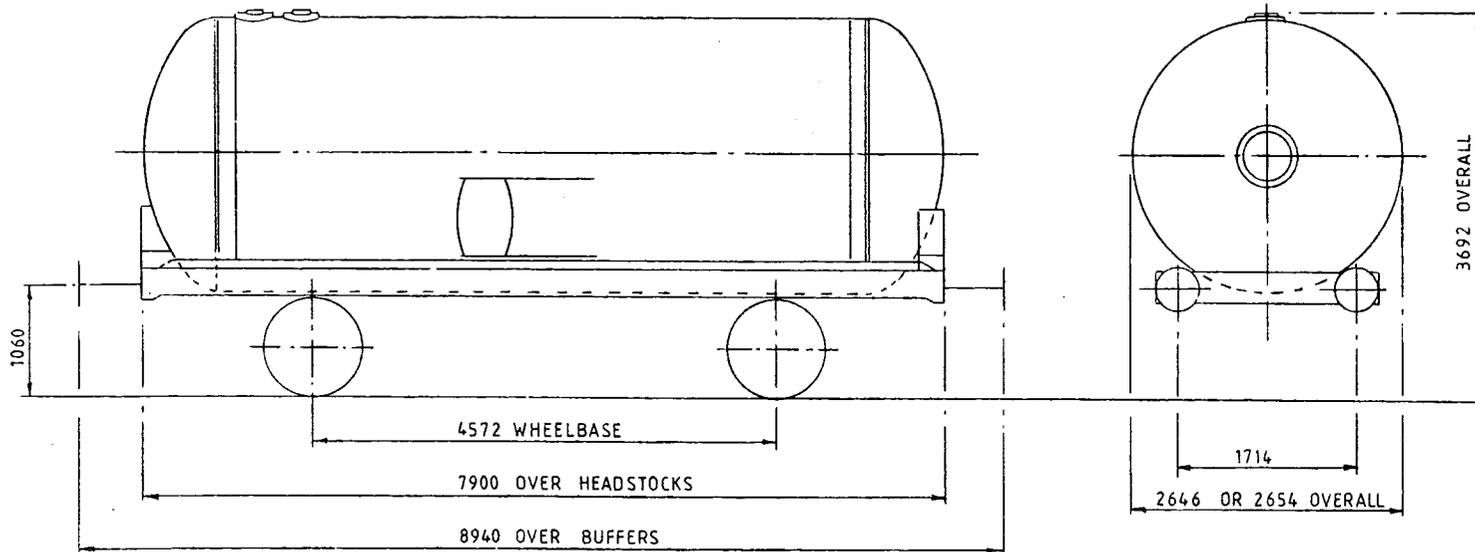

TARE-	18.720 Kg
CAPACITY, WEIGHT-	22.280 Kg
CAPACITY, VOLUME-	
MIN. CURVE-	31m SINGLY & CLOSE COUPLED
GEN. ARRGT. DRG. NO.-	

BRAKE-	AIR BLOCK & HAND LEVER
SUSPENSION-	DOUBLE LINK & PARABOLIC SPRING
COUPLINGS-	INSTANTER
BUFFERS-	HYDRAULIC 406 DIA HEADS
WHEELS-	952 DIA
JOURNALS-	140 DIA ROLLER BEARINGS

ISSUE 1

46 tonne GLW TANK WAGON-CLASS A

LOT NUMBER	

TOPS INFORMATION										
AARKND	OPERATING			OPERATING SPEED		BRAKE FORCE DATA		EXCESS LENGTH	RA (GLW)	DESIGN SHEET
CARKND	PANEL No.			45 mile/h UP TO	14 tonne GLW	12 t FORCE UP TO	28 tonne GLW	4	9	W1147
T T A A				60 mile/h ABOVE		25 t FORCE ABOVE				

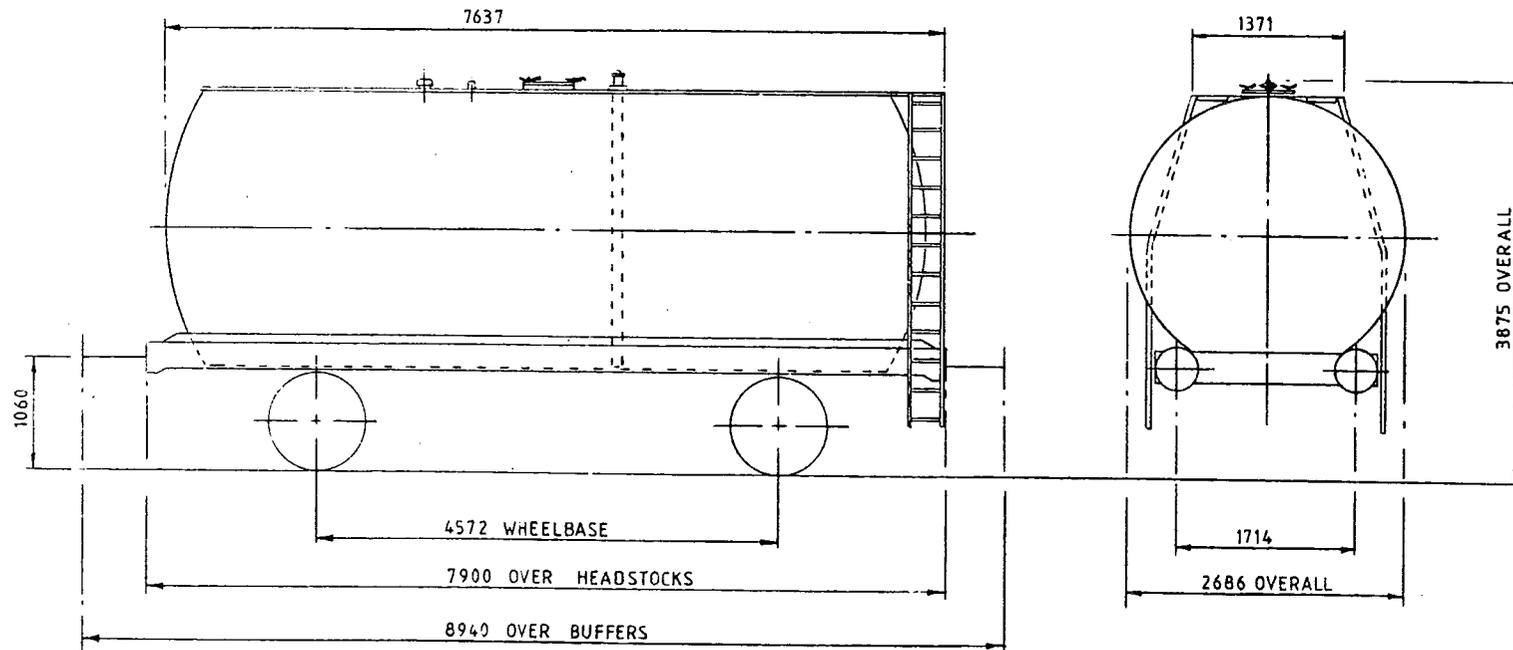

TARE-	13.650 Kg
CAPACITY, WEIGHT-	32.350 Kg
CAPACITY, VOLUME-	39.277 litres
MIN. CURVE-	31m SINGLY & CLOSE COUPLE
GEN. ARRGT. DRG. NO.-	

BRAKE-	AIR BLOCK & HAND LEVER
SUSPENSION-	DOUBLE LINK
COUPLINGS-	INSTANTER
BUFFERS-	HYDRAULIC 406 DIA HEADS
WHEELS-	952 DIA
JOURNALS-	140 DIA ROLLER BEARINGS

ISSUE I

46 tonne GLW TANK WAGON-CLASS A

LOT NUMBER	

TOPS INFORMATION						
AARKND	OPERATING	OPERATING SPEED		BRAKE FORCE DATA		EXCESS LENGTH
CARKND	PANEL No.	45 mile/h UP TO	14 tonne GLW	12 t FORCE UP TO	28 tonne GLW	RA (GLW)
T T A A		60 mile/h ABOVE		25t FORCE ABOVE		4
						9
						W1148

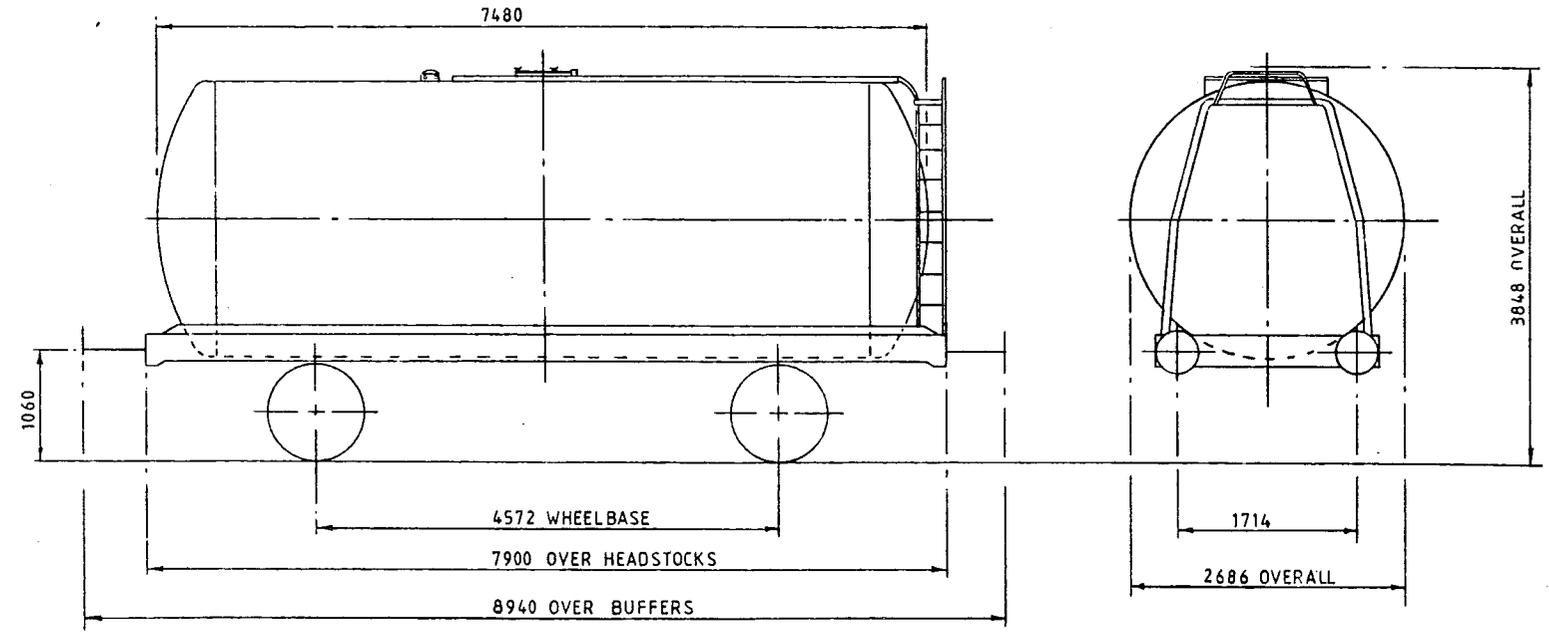

TARE-	13,300 Kg
CAPACITY, WEIGHT-	32,700 Kg
CAPACITY, VOLUME-	37,854 litres PETROL 38,440 litres KEROSENE GAS OIL
MIN. CURVE-	31m SINGLY & CLOSE COUPLED
GEN. ARRCT. DRG. NO.-	

BRAKE-	AIR BLOCK & HAND LEVER
SUSPENSION-	DOUBLE LINK
COUPLINGS-	INSTANTER
BUFFERS-	HYDRAULIC 406 DIA HEADS
WHEELS-	952 DIA
JOURNALS-	140 DIA ROLLER BEARINGS

ISSUE 1

41 tonne GLW L.P.G. TANK WAGON

DIAGRAM T002R

LOT NUMBER	

TOPS INFORMATION									
AARKND	OPERATING		OPERATING SPEED		BRAKE FORCE DATA		EXCESS LENGTH	RA (GLW)	DESIGN SHEET
CARKND	PANEL No.		60 mile/h UP TO mile/h ABOVE 41 tonne GLW		12 t FORCE UP TO 25 t FORCE ABOVE 21 tonne GLW				
T T A A							4	6	W1514

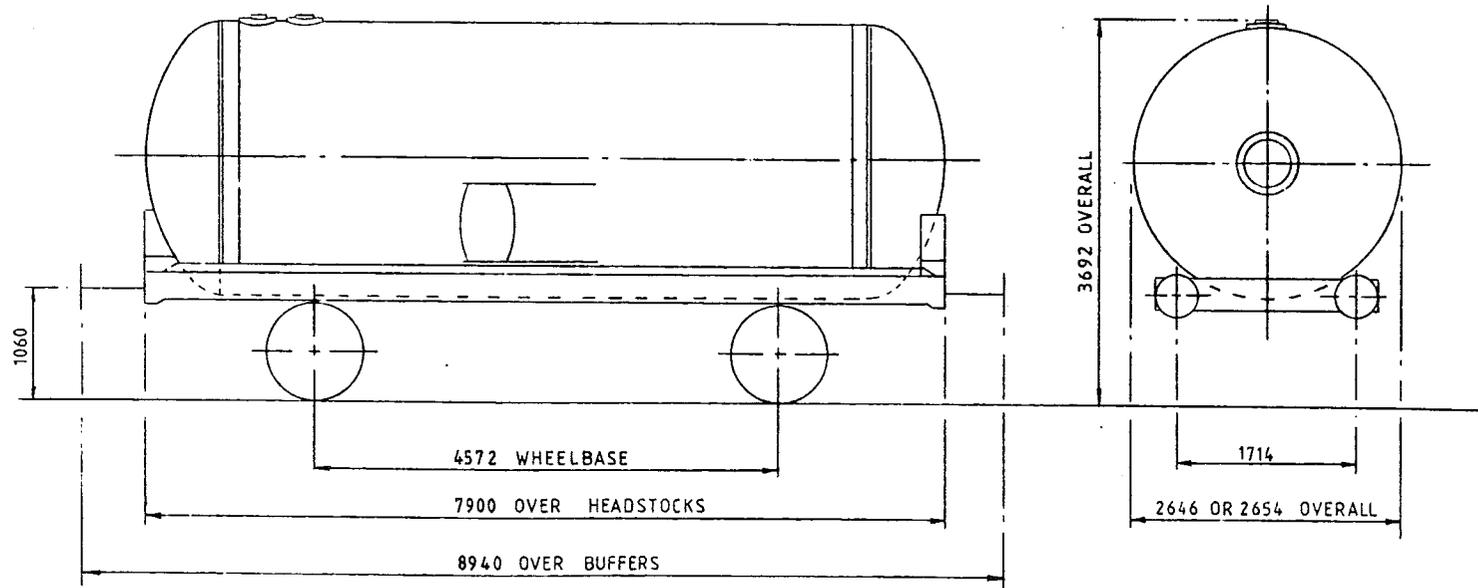

TARE-	18.200 Kg
CAPACITY, WEIGHT-	22.800 Kg
CAPACITY, VOLUME-	
MIN. CURVE-	31m SINGLY & CLOSE COUPLED
GEN. ARRGT. DRG. NO.-	

BRAKE-	AIR BLOCK & HAND LEVER
SUSPENSION-	DOUBLE LINK & PARABOLIC SPRING
COUPLINGS-	INSTANTER
BUFFERS-	HYDRAULIC 406 DIA HEADS
WHEELS-	952 DIA
JOURNALS-	140 DIA ROLLER BEARINGS

ISSUE I

41 tonnes G.L.W. TANK WAGON - LIQUEFIED PETROLEUM GAS.

TTOO3A

EXCESS LENGTH	4	H	M	L	E
tonnes	41	41	22	22	
VB	18	18	11	11	
AB					
RA	6	6	1	1	
MAX. SPEED	60	60	45	45	

TOPS CODE										
CARKND		AARKND			OPERATING PANEL No					
T	T	V	T	T	V	A	1	2	7	6

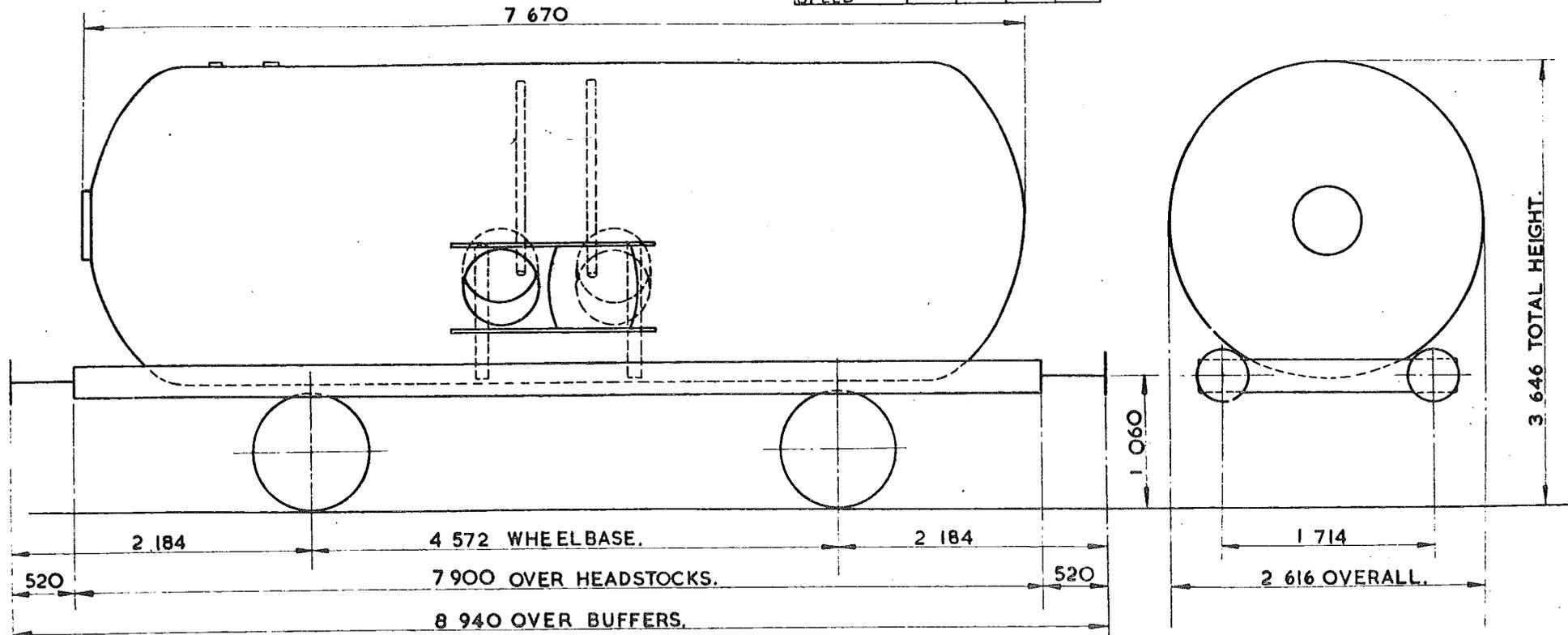

TARE -	21 950 kg
CARRYING CAPACITY -	15 500 kg PROPANE 19 000 kg BUTANE
CAPACITY -	
MAX. SPEED -	60 mile/h
WHEELS -	952 DIA.
JOURNALS -	140 DIA. ROLLER BEARINGS.

BUFFERS -	HYDRAULIC 406 DIA. HEADS
COUPLINGS -	INSTANTER.
MIN. CURVE -	31 m
GEN. ARRGT. DRG. No. -	
BRAKE -	VACUUM BLOCK & HAND LEVER
SUSPENSION -	EYEBOLT.

BUILDER -	METRO-CAMELL.
OWNER -	SUKO
REGISTERED BY -	C.M. & E.E. (B.R.B) DERBY
YEAR BUILT -	1964.
REGISTRATION Nos. -	SUKO 59124 TO 59138
OWNERS Nos. -	

ISSUE 2
EX. P.O. DIAGRAM. 6 / 129.

41 tonnes G.L.W. TANK WAGON - LIQUEFIED PETROLEUM GAS

TT 003 B

EXCESS LENGTH	4	H	M	L	E
tonnes	41	41	22	22	
VB					
AB	25	25	1	1	
RA	6	6	1	1	
MAX SPEED	60	60	45	45	

TOPS CODE										
CARKND			AARKND			OPERATION PANEL N				
T	T	A	T	T	A	A	1	3	6	1

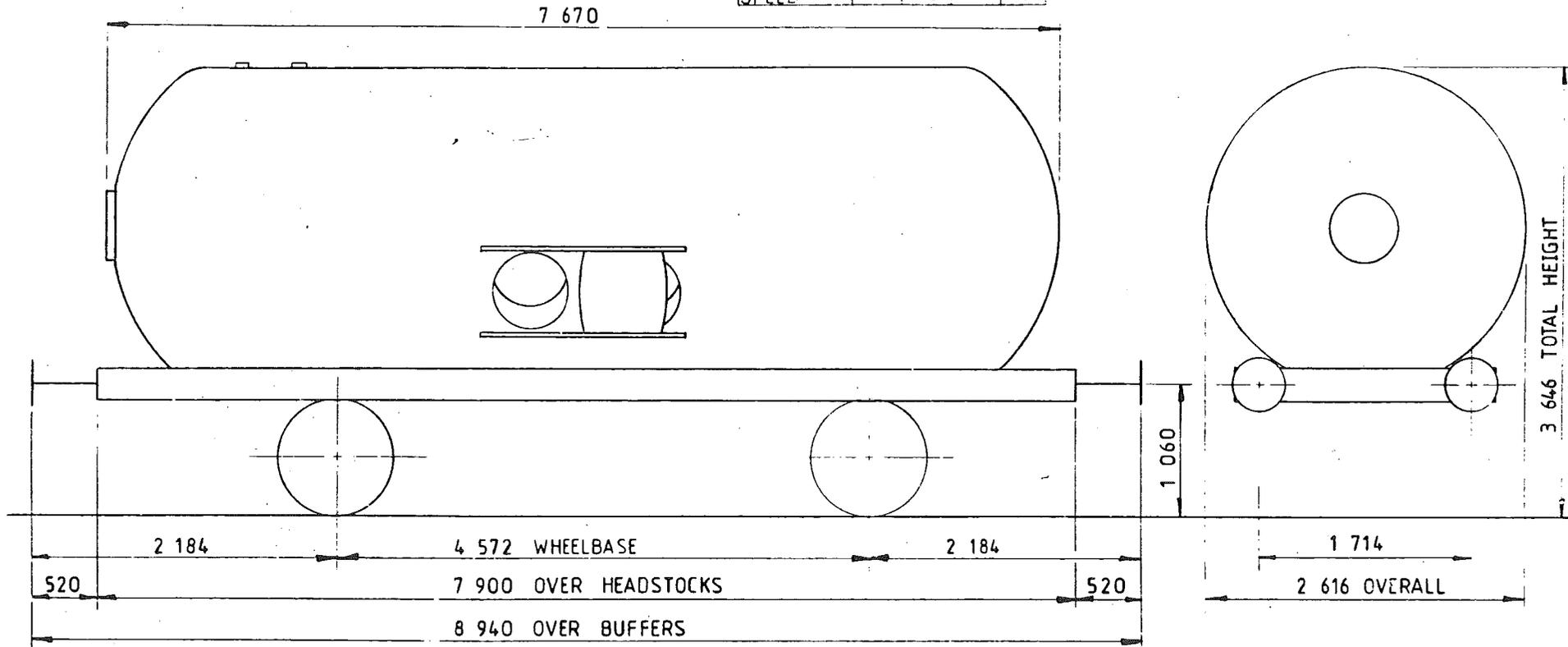

TARE -	21050 kg
CARRYING CAPACITY -	15500 kg PROPANE, 19000 kg BUTANE
CAPACITY -	
MAX SPEED	60 mile/h
WHEELS -	952 DIA.
JOURNALS -	140 DIA ROLLER BEARINGS

BUFFERS	HYDRAULIC 406 DIA HEADS
COUPLINGS	INSTANTER
MIN. CURVE	31 m
GEN ARRGT DRG No.	-
BRAKE	AIR BLOCK & HAND LEVER
SUSPENSION	EYEBOLT

ISSUE 1

EX PO, DIAGRAM 6/129 (ALLOCATED)

41 tonnes G.L.W. TANK WAGON - LIQUEFIED PETROLEUM GAS

TT 003 C

EXCESS LENGTH	H	M	L	E
4				
tonnes	41	41	22	22
VB				
AB	26	26	17	17
CA	6	6	1	1
MAX SPEED	60	60	60	60

TOPS CODE		
CARKND	AARKND	OPERATION PANEL
T	T	A
A	T	A
A	A	1
		3
		7
		5

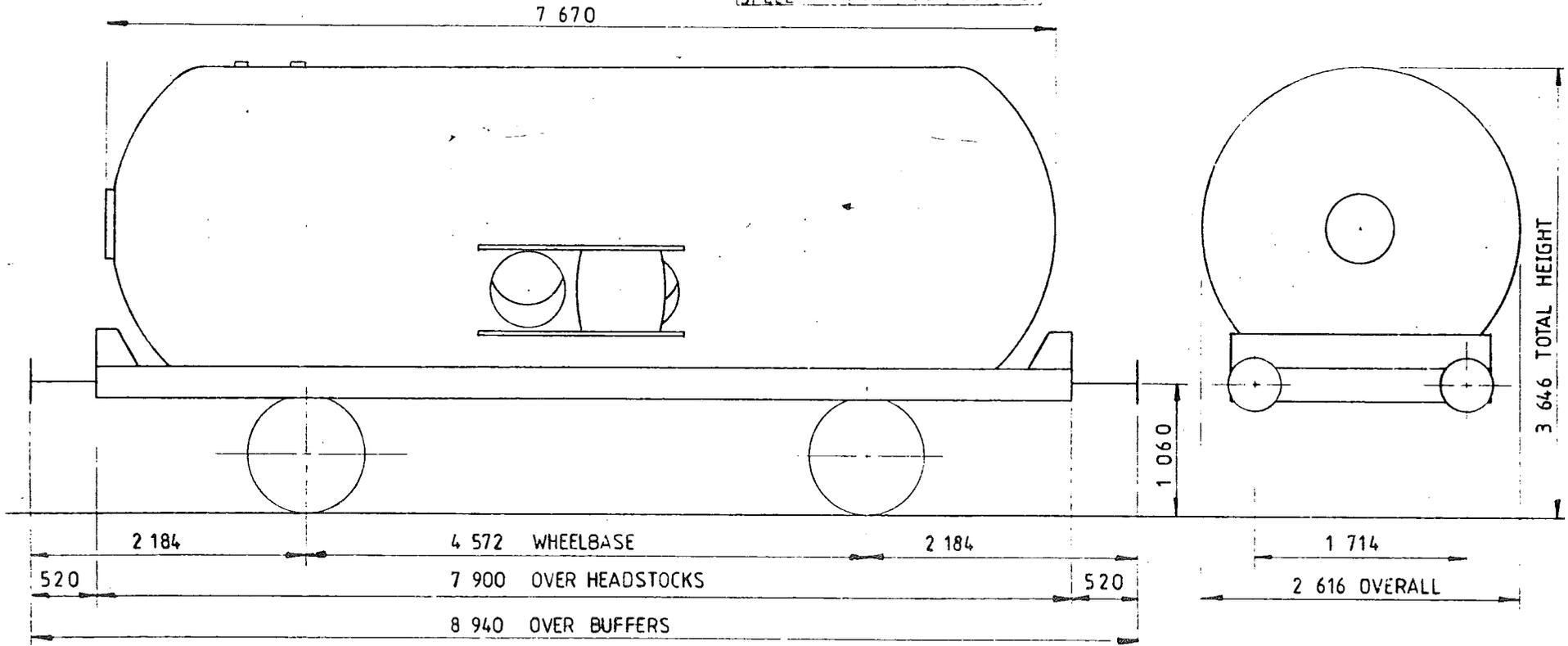

TARE	21 500kg
CARRYING CAPACITY -	15 500kg PROPANE, 19 000kg BUTANE
CAPACITY -	
MAX SPEED	60 mile/h
WHEELS	952 DIA.
JOURNALS	140 DIA. ROLLER BEARINGS

BUFFER	HYDRAULIC 406 DIA HEADS
COUPLINGS	INSTANTER
MIN CURVE	31 m
GEN ARRGT DRG No	
BRAKE	AIR BLOCK & HAND LEVER
SUSPENSION	PRIMARY COIL-PEDESTAL

ISSUE 1

EX PO DIAGRAM 61/129 (ALLOCATED)

41 tonne GLW TANK WAGON

TT003D

EXCESS LENGTH	H	M	L	E
4 tonnes	41	41	22	22
VB				
AB	25	25	12	12
RA	8	8	1	1
MAX SPEED	60	60	45	45

TOPS CODE										
CARKND		AARKND			OPERATION PANEL					
T	T	A	T	T	A	A	1	6	3	1

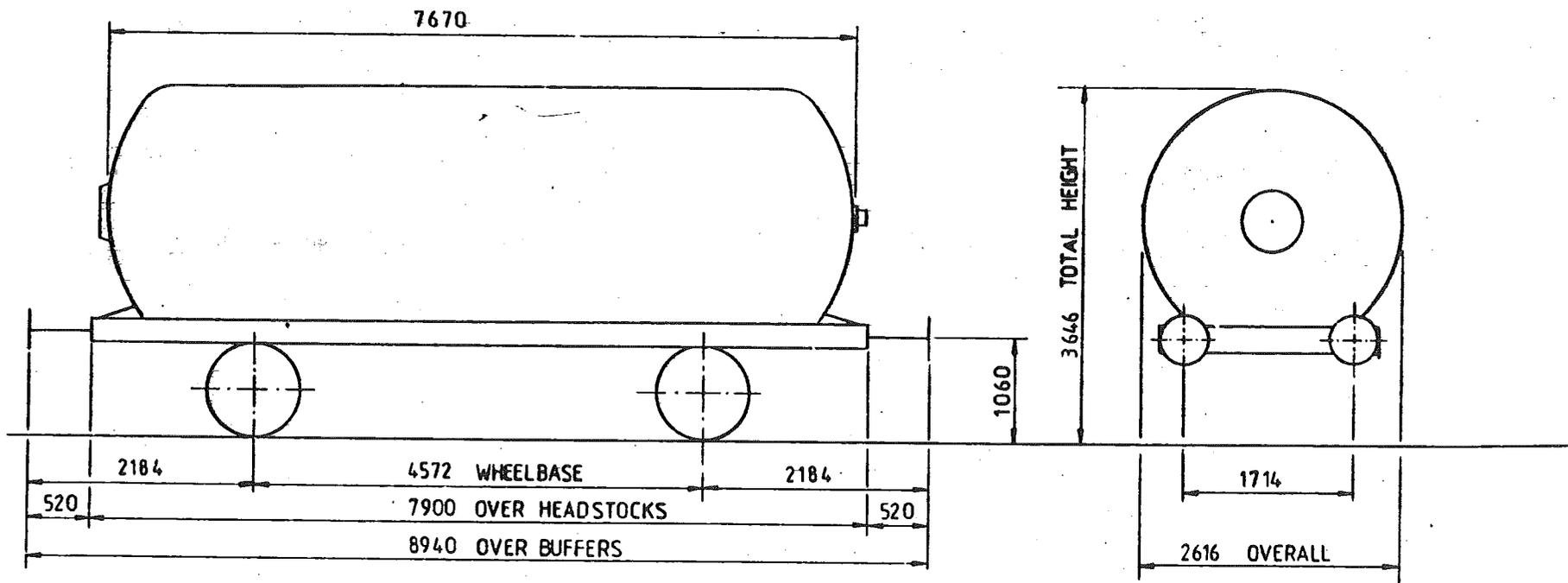

TARE	21950 kg
CARRYING CAPACITY -	15 ⁵⁰⁰ kg (Propane), 19 ⁰⁰⁰ kg (Butane)
CAPACITY -	Litres
MAX SPEED	60 mile/h
WHEELS	φ 952
JOURNALS	φ 140 ROLLER BEARINGS

BUFFERS	HYDRAULIC φ 406 HEADS
COUPLINGS	INSTANTER
MIN CURVE	31m
GEN ARRGT DRG No	
BRAKE	AIR BLOCK, HAND LEVER
SUSPENSION	FAT 26

ISSUE 1

EX PO. DIAGRAM 6/129

41 tonne GLW TANK WAGON L.P.G.

LOT NUMBER	

TOPS INFORMATION											
AARKND		OPERATING		OPERATING SPEED		BRAKE FORCE DATA		EXCESS LENGTH	RA (GLW)	DESIGN SHEET	
CARKND		PANEL No.		60 mile/h UP TO		41 tonne GLW		9 t FORCE UP TO	4	8	W1018
T T A A				mile/h ABOVE		22 t FORCE ABOVE		25 tonne GLW			

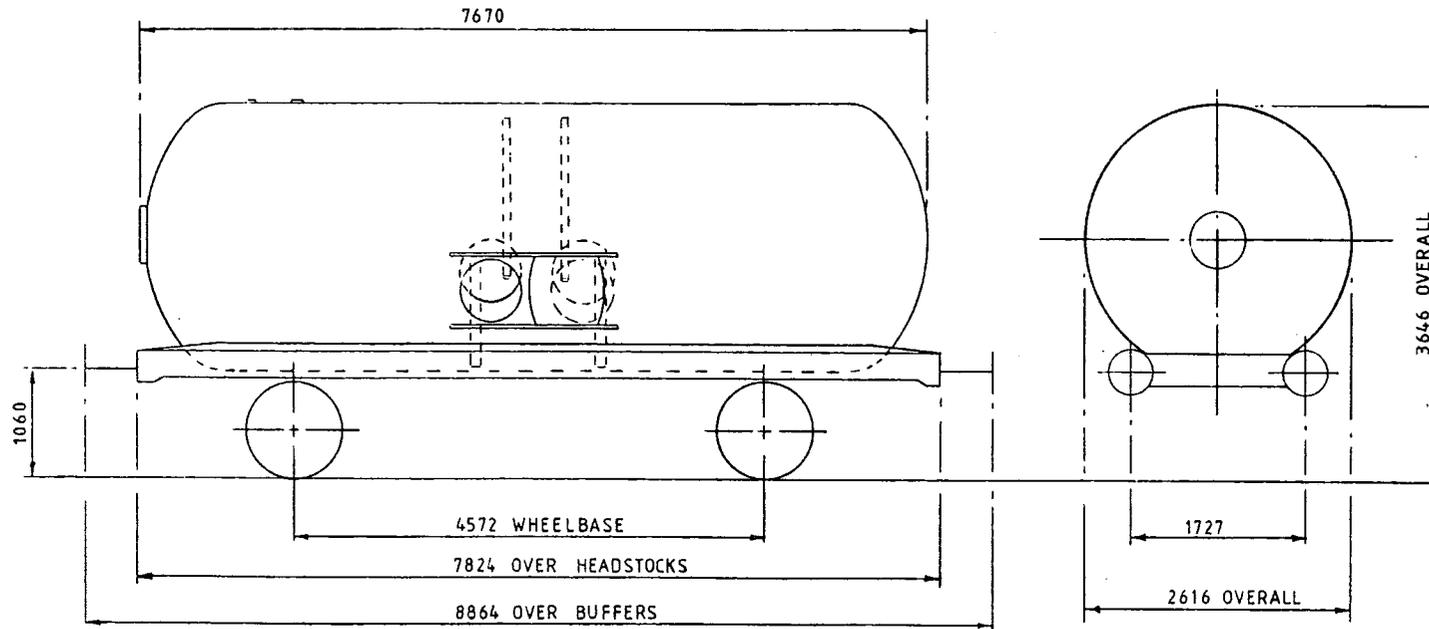

TARE-	21.900 Kg
CAPACITY, WEIGHT-	19.100 Kg
CAPACITY, VOLUME-	
MIN. CURVE-	31m
GEN. ARRGT. DRG. NO.-	

BRAKE-	AIR BLOCK & HAND LEVER
SUSPENSION-	DOUBLE LINK & PARABOLIC SPRING
COUPLINGS-	INSTANTER
BUFFERS-	HYDRAULIC 406 DIA HEADS
WHEELS-	952 DIA
JOURNALS-	140 DIA ROLLER BEARINGS

ISSUE 1

41 tonne GLW TANK WAGON L.P.G.

LOT NUMBER	

TOPS INFORMATION											
AARKND		OPERATING		OPERATING SPEED			BRAKE FORCE DATA		EXCESS LENGTH	RA (GLW)	DESIGN SHEET
CARKND		PANEL No.		60 mile/h UP TO 41 tonne GLW			9t FORCE UP TO 25 tonne GLW		4	7	W1140
T	T	A	A								

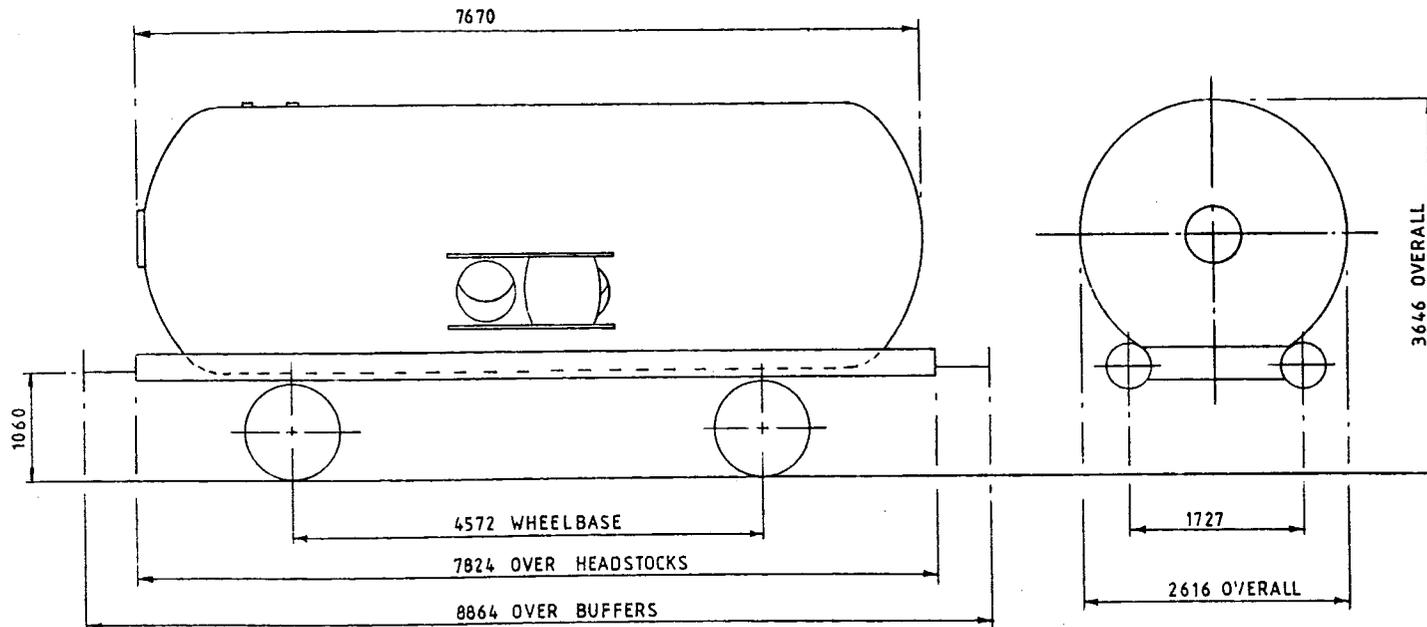

TARE-	21.400 Kg
CAPACITY, WEIGHT-	19.600 Kg
CAPACITY, VOLUME-	
MIN. CURVE-	31m
GEN. ARRGT. DRG. NO.-	

BRAKE-	AIR BLOCK & HAND LEVER
SUSPENSION-	SINGLE LINK & PARABOLIC SPRING
COUPLINGS-	INSTANTER
BUFFERS-	HYDRAULIC 406 DIA HEADS
WHEELS-	952 DIA
JOURNALS-	140 DIA ROLLER BEARINGS

ISSUE 1

41 tonnes G.L.W. TANK WAGON.

TT004A

EXCESS LENGTH	4	H	M	L	E
tonnes	41	41	13	13	
VB	22	22	8	8	
AB					
RA	6	6	1	1	
MAX SPEED	60	60	45	45	

TOPS CODE										
CARKND		AARKND			OPERATING PANEL No.					
T	T	V	T	T	V	A	1	4	2	3

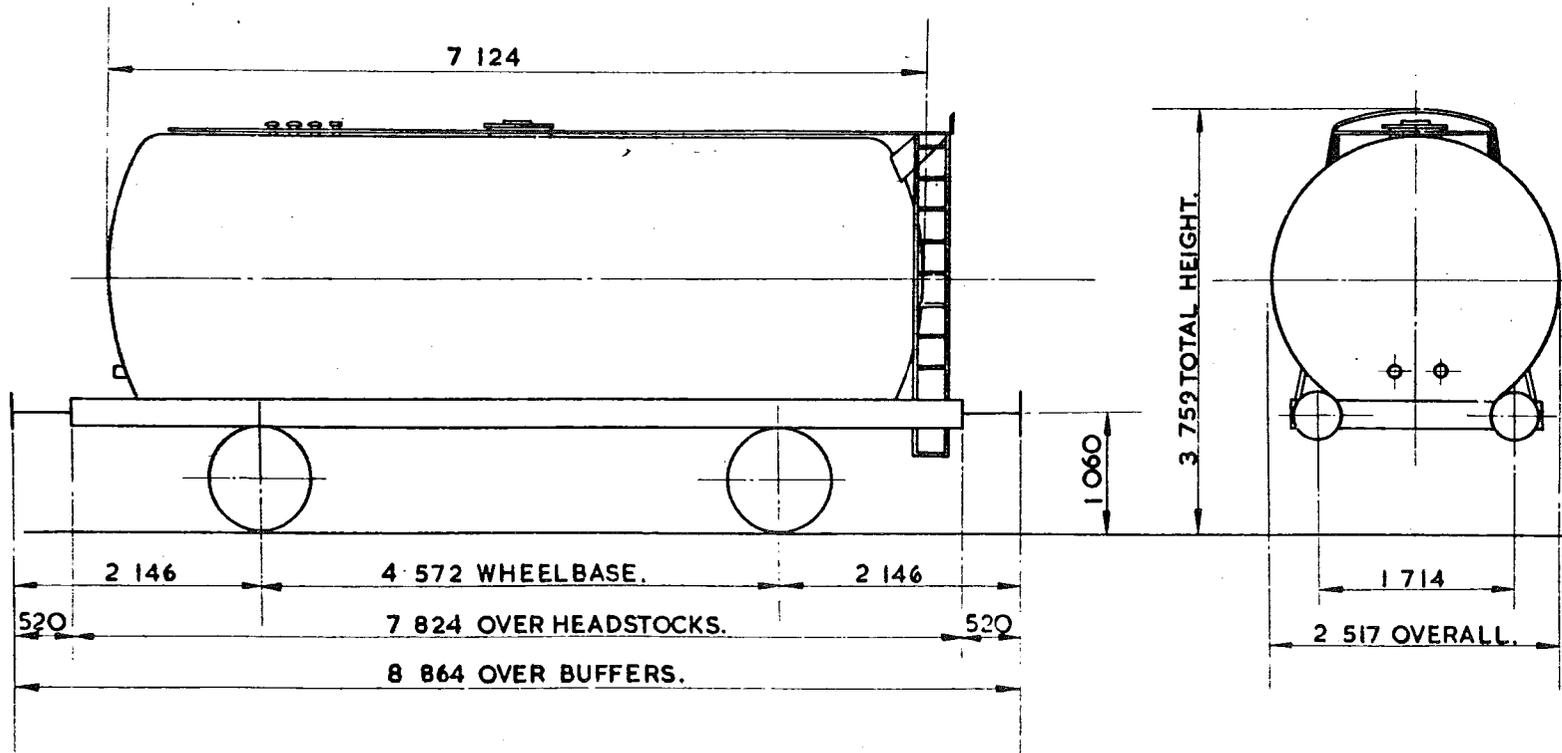

TARE -	12700 kg
CARRYING CAPACITY -	28300 kg
CAPACITY -	32772 litres
MAX. SPEED -	60 mile/h
WHEELS -	952 DIA.
JOURNALS -	140 DIA. ROLLER BEARINGS.

BUFFERS -	HYDRAULIC 406 DIA. HEADS
COUPLINGS -	INSTANTER.
MIN. CURVE -	31 m
GEN. ARRGT. DRG. No. -	
BRAKE -	VACUUM BLOCK & HAND LEVER
SUSPENSION -	EYE BOLT.

BUILDER -	CHARLES ROBERTS.
OWNER -	HARGREAVES FUEL OILS.
REGISTERED BY -	C.M. & E.E. (B.R.B.) DERBY
YEAR BUILT -	1964.
REGISTRATION Nos. -	53901. TO 53921.
OWNERS Nos. -	1. TO 21.

ISSUE 2

EX. P.O. DIAGRAM. 6/116. (ALLOCATED)

41 tonnes G.L.W. TANK WAGON

TTOO4B

EXCESS LENGTH	4	H	M	L	E
tonnes	41	41	13	13	
VB	20	20	8	8	
AB					
RA	6	6	1	1	
MAX. SPEED	60	60	45	45	

TOPS CODE										
CARKND		AARKND		OPERATING PANEL No						
T	T	V	T	T	V	A	1	4	5	8

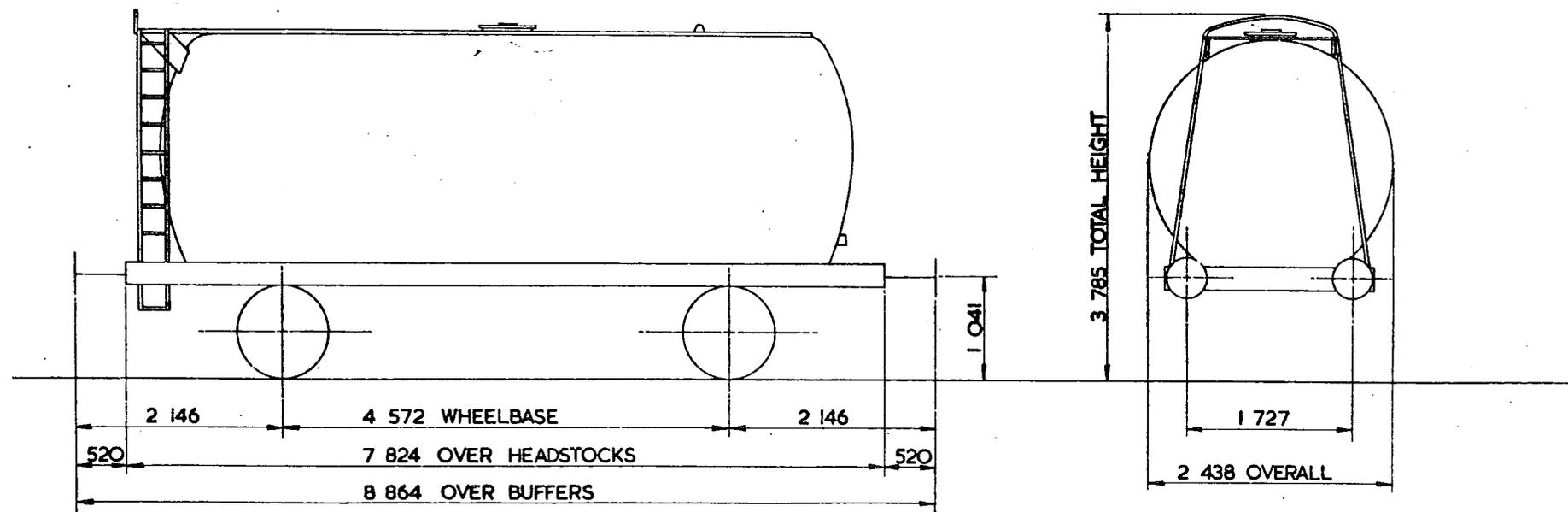

TARE - 12 ⁶⁰⁰ kg
CARRYING CAPACITY - 28 ⁴⁰⁰ kg
CAPACITY - 32 ⁶⁸⁶ litres
MAX. SPEED - 60 mile/h
WHEELS - 952 DIA
JOURNALS - 140 DIA ROLLER BEARINGS

BUFFERS - HYDRAULIC 406 DIA HEADS
COUPLINGS - INSTANTER
MIN. CURVE - 31 m
GEN. ARRGT. DRG No. -
BRAKE - VACUUM BLOCK & HAND LEVER
SUSPENSION - EYEBOLT

BUILDER - CHARLES ROBERTS
OWNER - SUKO & BPO
REGISTERED BY - C.M. & E.E. (B.R.B.) DERBY
YEAR BUILT - 1964
REGISTRATION Nos. SUKO 50100 - 50111 BPC 50160 - 50167
OWNERS Nos. -

ISSUE 2

41 tonnes G.L.W. TANK WAGON.

TTO04C

EXCESS LENGTH	4	H	M	L	E
tonnes	41	41	14	14	
VB	20	20	9	9	
AB					
RA	6	6	1	1	
MAX. SPEED	60	60	45	45	

TOPS CODE										
CARKND		MARKND		OPERATION PANEL No.						
T	T	V	T	T	V	A	1	4	2	5

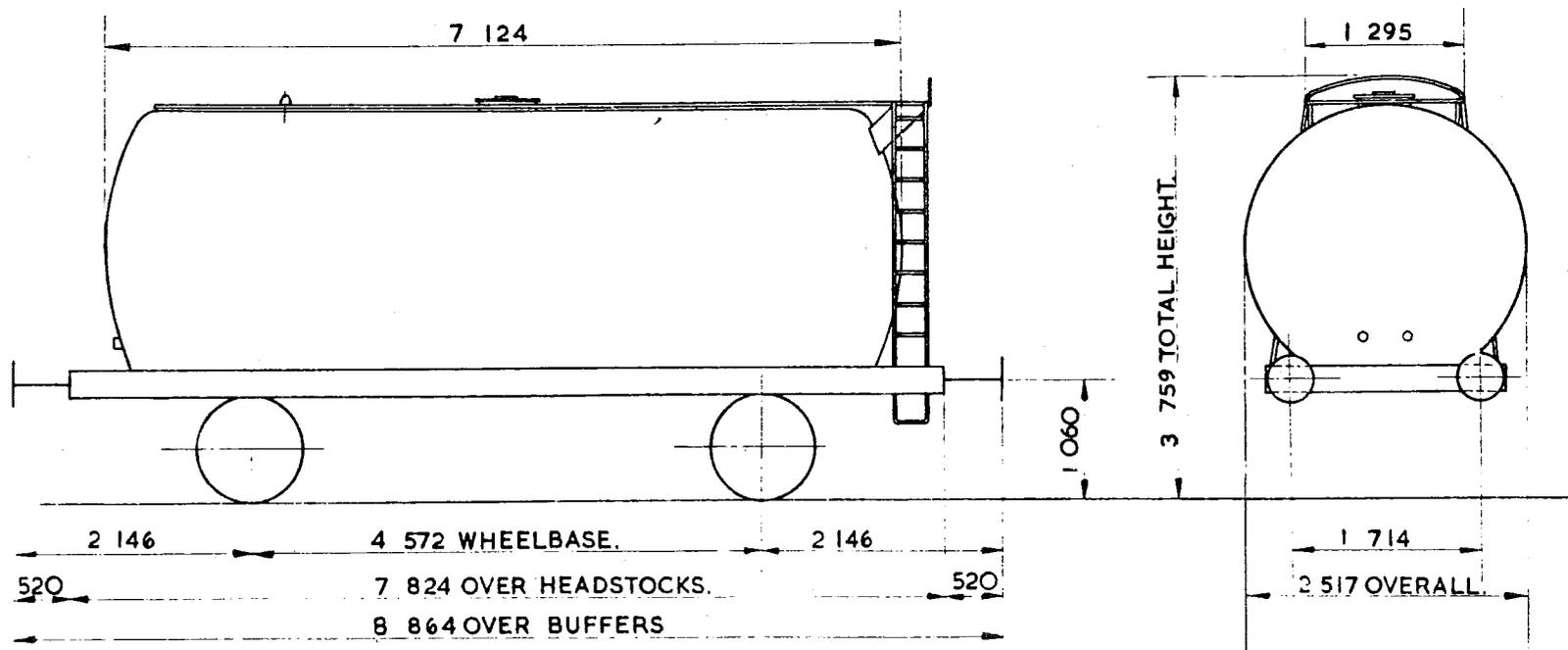

TARE --	13 550 kg
CARRYING CAPACITY--	27 400 kg
CAPACITY--	32 772 litres
MAX SPEED	60 mile/h
WHEELS--	952 DIA.
JOURNALS --	140 DIA. ROLLER BEARINGS.

BUFFERS--	HYDRAULIC 406 DIA. HEADS
COUPLINGS --	INSTANTER.
MIN. CURVE --	31m
GEN. ARRGT. DRG No. --	
BRAKE --	VACUUM BLOCK & HAND LEVER
SUSPENSION --	EYEBOLT.

BUILDER	CHARLES ROBERTS.
OWNER	TIGER RAILCAR LEASING.
REGISTERED BY --	C.M. & E.E. (B.R.B.) DERBY
YEAR BUILT	1964.
REGISTRATION Nos --	51299. TO 51338.
OWNERS Nos --	A 299. TO. A 338.

ISSUE 2

EX PO DIAGRAM 6 /97.

41 tonnes G.L.W. TANK WAGON CLASS 'A'

TTO05A

EXCESS LENGTH	4	H	M	L	E
tonnes	41	41	13	13	
VB	20	20	8	8	
AB					
RA	6	6	1	1	
MAX SPEED	60	60	45	45	

TOPS CODE										
CARKND		AARKND			OPERATING PANEL No					
T	T	V	T	T	V	A	1	4	5	8

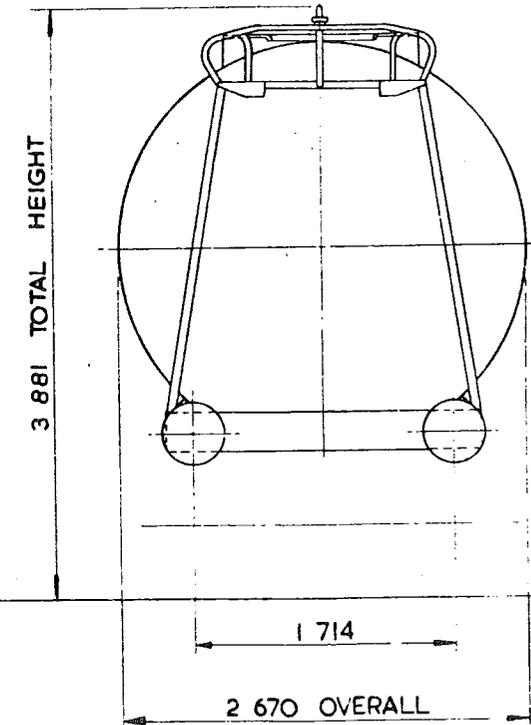
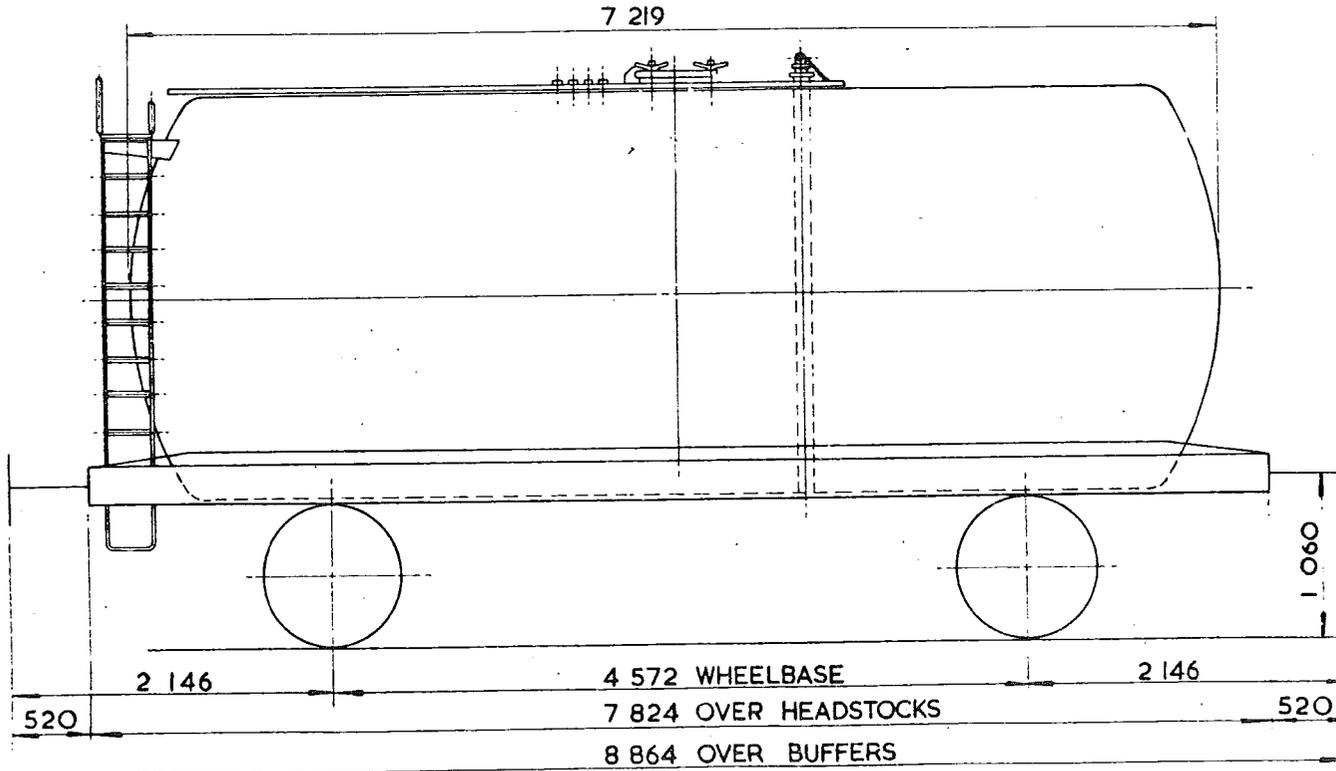

TARE - 12 450 kg
CARRYING CAPACITY - 28 500 kg
CAPACITY - 38 140 litres
MAX SPEED - 60 mile/h
WHEELS - 952 DIA.
JOURNALS - 140 DIA. ROLLER BEARINGS

BUFFERS - HYDRAULIC 406 DIA. HEADS
COUPLINGS - INSTANTER
MIN CURVE - 31m
GEN ARRGT DRG. No -
BRAKE - VACUUM BLOCK & HAND LEVER
SUSPENSION - DOUBLE LINK

BUILDER - POWELL, DUFFRYN
OWNER - BRITISH RAILWAY TRAFFIC & ELECTRIC
REGISTERED BY - C.M. & E.E. (B.R.B) DERBY
YEAR BUILT - 1962
REGISTRATION Nos - 57000 TO 57040
OWNERS Nos - 5523 TO 5572 (RANGE)

ISSUE 2

EX. P.O. DIAGRAM 6/107

41 tonnes GL.W. TANK WAGON - CLASS A

TT005B

EXCESS LENGTH	4	H	M	L	E
tonnes	41	41	13	13	
VB	18	18	9	9	
AB					
RA	6	6	1	1	
MAX. SPEED	60	60	45	45	

TOPS CODE							
CARKND		AARKND		OPERATING PANEL No			
T	T	F	T	T	F	A	1 4 2 4

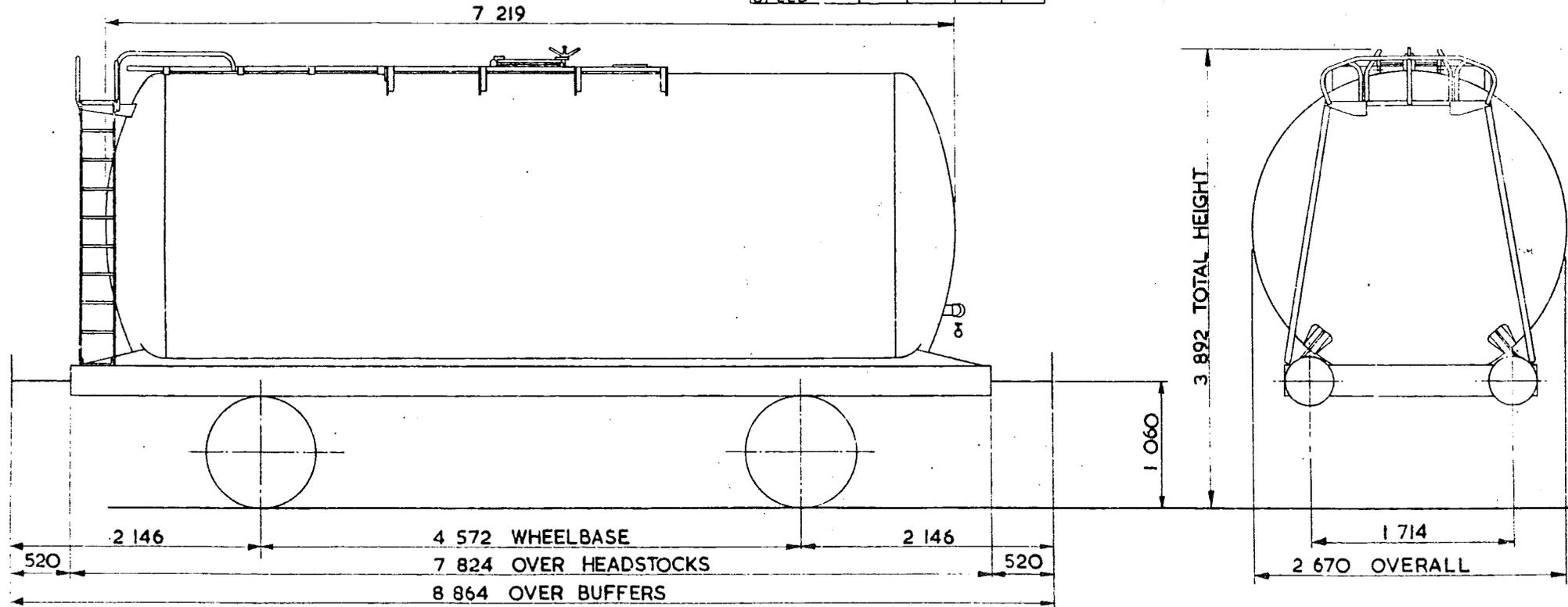

TARE - 12 800 kg
CARRYING CAPACITY - 28 200 kg
CAPACITY - 37 777 litres
MAX SPEED - 60 mile/h
WHEELS - 952 DIA.
JOURNALS - 140 DIA. ROLLER BEARINGS

BUFFERS - HYDRAULIC 406 DIA. HEADS
COUPLINGS - INSTANTER
MIN. CURVE - 31m
GEN. ARRGT. DRG. No. -
BRAKE - VACUUM BLOCK & HAND LEVER
SUSPENSION - DOUBLE LINK

BUILDER - POWELL DUFFRYN
OWNER - BRITISH RAILWAY TRAFFIC & ELECTRIC
REGISTERED BY - C.M. & E.E. (B.R.B.) DERBY
YEAR BUILT - 1967
REGISTRATION Nos. - 57345 - 57349
OWNERS Nos. - 6155 - 6159

ISSUE 2

EX. PO. DIAGRAM 6/636 (ALLOCATED)

41 tonnes G.L.W. TANK WAGON - CLASS B

TTO07A

EXCESS LENGTH	4	H	M	L	E
tonnes	41	41	13	13	
VB	18	18	7	7	
AB					
RA	6	6	1	1	
MAX. SPEED	60	60	45	45	

TOPS CODE										
CARKND		AARKND			OPERATING PANEL No					
T	T	V	T	T	V	A	1	2	7	9

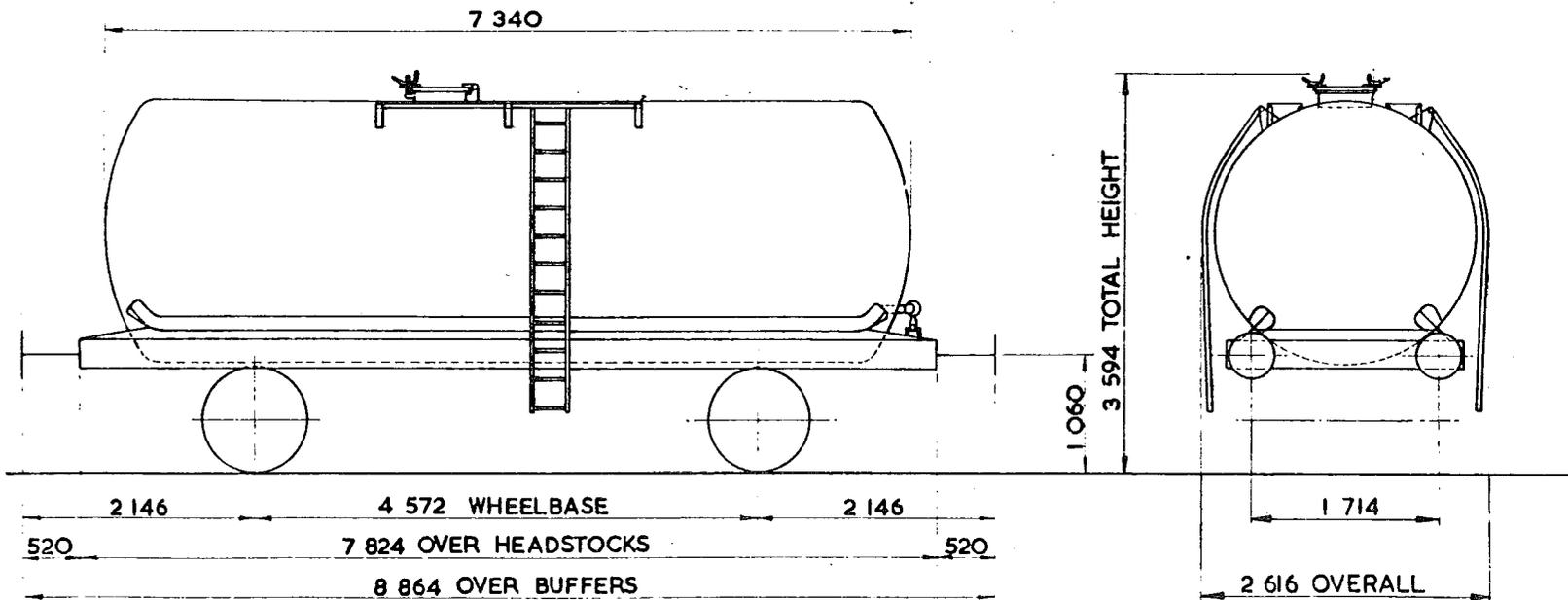

TARE - 12 600 kg
CARRYING CAPACITY - 28 400 kg
CAPACITY - 29 094 litres
MAX. SPEED - 60 mile/h
WHEELS - 952 DIA.
JOURNALS - 140 DIA ROLLER BEARINGS

BUFFERS - HYDRAULIC 406 DIA. HEADS
COUPLINGS - INSTANTER
MIN. CURVE - 31 m
GEN. ARRGT. DRG. No. -
BRAKE - VACUUM BLOCK & HAND LEVER
SUSPENSION - EYEBOLT

BUILDER - CHARLES ROBERTS
OWNER - CHARRINGTON, GARDNER, LOCKET LTD.
REGISTERED BY - C.M. & E.E.(B.R.B.) DERBY
YEAR BUILT - 1963
REGISTRATION Nos. - 53701 TO 53720
OWNERS Nos. - 401 TO 420

ISSUE 2

EX. P.O. DIAGRAM 6/100 (ALLOCATED)

41 tonnes G.L.W. TANK WAGON - CLASS B

TTO07B

EXCESS LENGTH	4	H	M	L	E
tonnes	41	41	13	13	
VB	21	21	8	8	
AB					
RA	6	6	1	1	
MAX SPEED	55	55	45	45	

TOPS CODE							
CARKND	AARKND			OPERATING PANEL No.			
T	T	V	T	T	V	A	1 4 2 7

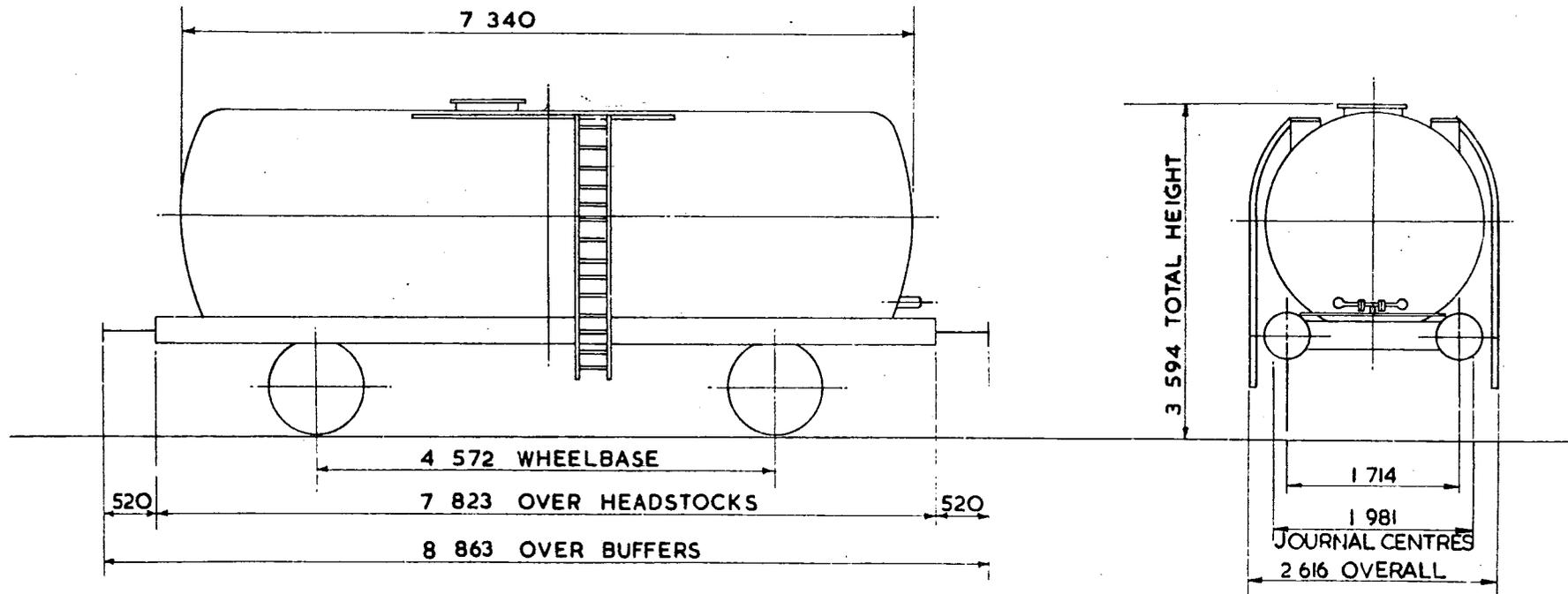

TARE -	12800 kg
CARRYING CAPACITY -	28200 kg
CAPACITY -	29549 litres
MAX SPEED	55 mile/h
WHEELS	952 DIA.
JOURNALS -	140 DIA. ROLLER BEARINGS

BUFFERS -	HYDRAULIC 406 DIA. HEADS
COUPLINGS	INSTANTER
MIN CURVE -	31 m
GEN. ARRGT. DRG No.	
BRAKE -	VACUUM BLOCK & HAND LEVER
SUSPENSION -	EYEBOLT

BUILDER -	CHARLES ROBERTS
OWNER	HARGREAVES FUEL OIL
REGISTERED BY -	C.M. & E.E. (B.R.B.) DERBY
YEAR BUILT -	1971
REGISTRATION Nos.	53905
OWNERS Nos.	005

ISSUE 2
EX. P.O. DIAGRAM 6/99

41 tonnes G.L.W. TANK-EYTHELENE GLYCOL

TTO07C

EXCESS LENGTH	4	H	M	L	E
tonnes	41	41	14	14	
VB	21	21	7	7	
AB					
RA	6	6	1	1	
MAX SPEED	60	60	45	45	

TOPS CODE										
CARKND			AARKND			OPERATING PANEL No.				
T	T	V	T	T	V	A	1	4	2	8

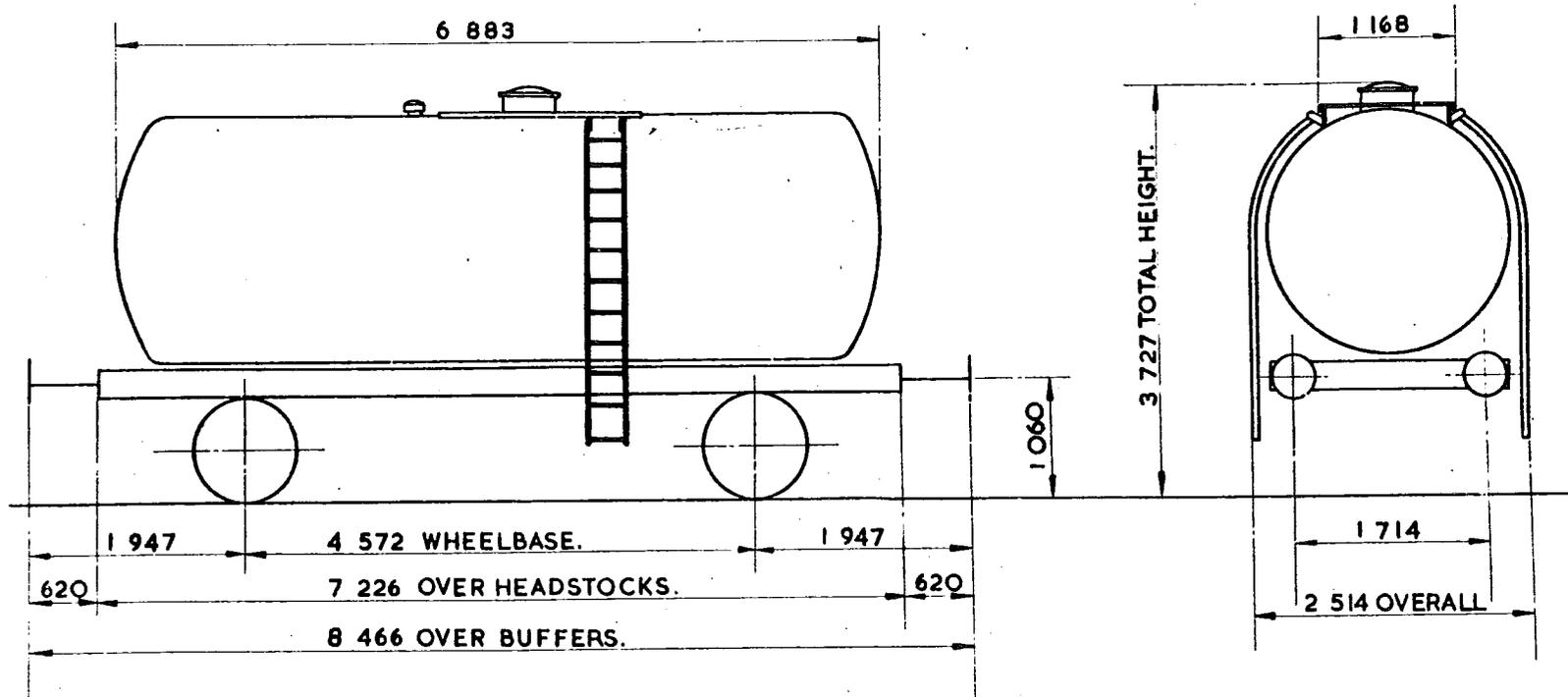

TARE -	13800 kg
CARRYING CAPACITY -	27200 kg
CAPACITY -	23703 litres
MAX. SPEED -	60 mile/h
WHEELS -	952 DIA.
JOURNALS -	140 DIA. ROLLER BEARINGS.

BUFFERS -	HYDRAULIC 406 DIA. HEADS
COUPLINGS -	INTERNATIONAL SCREW..
MIN. CURVE -	31m
GEN. ARRGT. DRG. No. -	
BRAKE -	VACUUM BLOCK & HAND LEVER
SUSPENSION -	EYEBOLT.

BUILDER -	CHARLES ROBERTS.
OWNER -	TIGER RAILCAR LEASING.
REGISTERED BY -	C.M.&E.E. (B.R.B.) DERBY
YEAR BUILT -	1962.
REGISTRATION Nos. -	51222 TO 51232.
OWNERS Nos. -	A.222 TO A.232.

ISSUE 2

EX. P.O. DIAGRAM 6/93.

41 tonnes G.L.W. TANK-CLASS B

TTO07D

EXCESS LENGTH	4	H	M	L	E
tonnes	41	41	15	15	
VB	26	26	7	7	
AB					
RA	6	6	1	1	
MAX SPEED	60	60	45	45	

TOPS CODE										
CARKND		AARKND			OPERATING PANEL NO.					
T	T	V	T	T	V	A	1	4	2	9

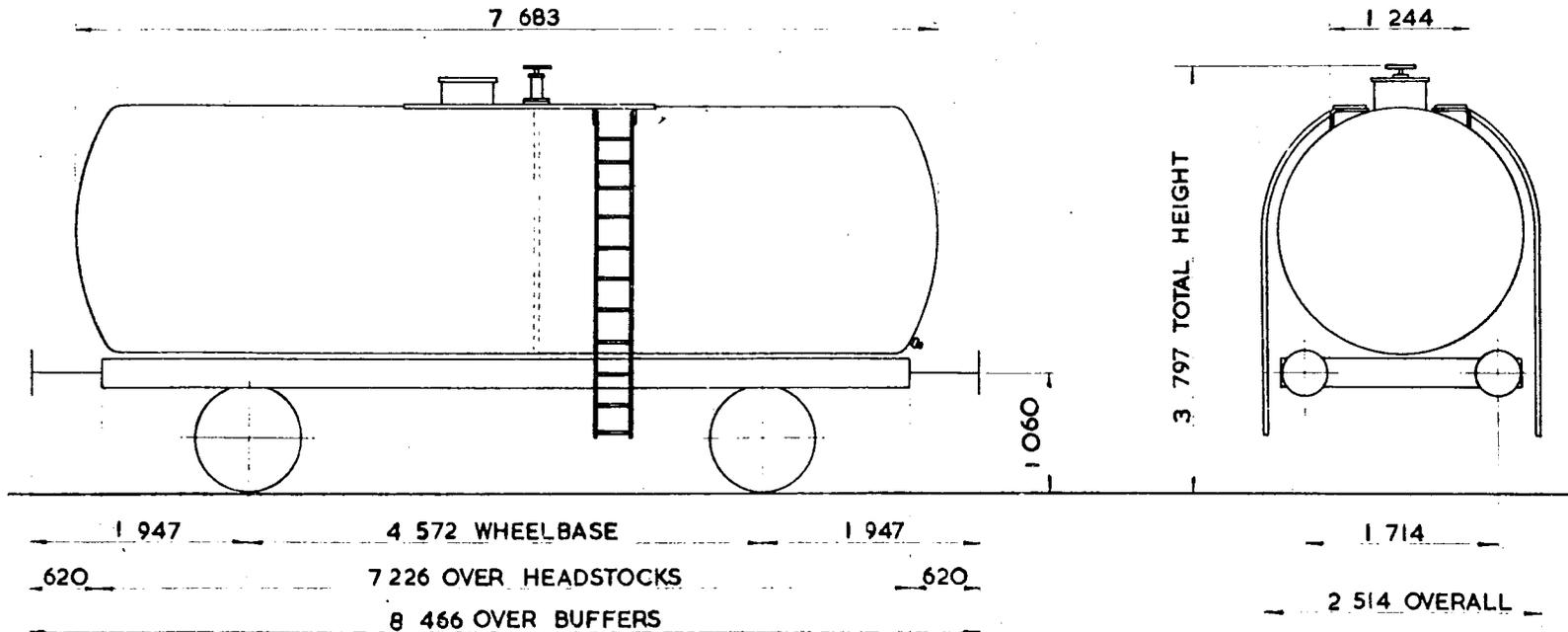

TAPE	14 200kg
CARRYING CAPACITY-	26800 kg
CAPACITY-	27135 litres
MAX. SPEED -	60 mile/h
WHEELS -	952 DIA.
JOURNALS -	140 DIA. ROLLER BEARINGS

BUFFERS -	HYDRAULIC 406 DIA. HEADS
COUPLINGS -	INTERNATIONAL SCREW
MIN CURVE -	31m
GEN. ARRGT. DRG No -	
BRAKE -	VACUUM BLOCK & HAND LEVER
SUSPENSION -	EYEBOLT

BUILDER -	CHARLES ROBERTS
OWNER -	TIGER RAILCAR LEASING.
REGISTERED BY -	C.M. & E.E. (B.R.B.) DERBY
YEAR BUILT -	1962
REGISTRATION Nos -	51258 TO 51279
OWNERS Nos -	A 258 TO A279

ISSUE 2

EX PO. DIAGRAM 6.94

41 tonnes G.L.W. TANK WAGON

TTO08A.

EXCESS LENGTH	4	H	M	L	E
tonnes.	41	41	11	11	
VB	13	13	4	4	
AB					
RA	6	6	1	1	
MAX SPEED	60	60	45	45	

TOPS CODE										
CARKND		AARKND			OPERATING PANEL No					
T	T	V	T	T	V	A	1	2	8	2

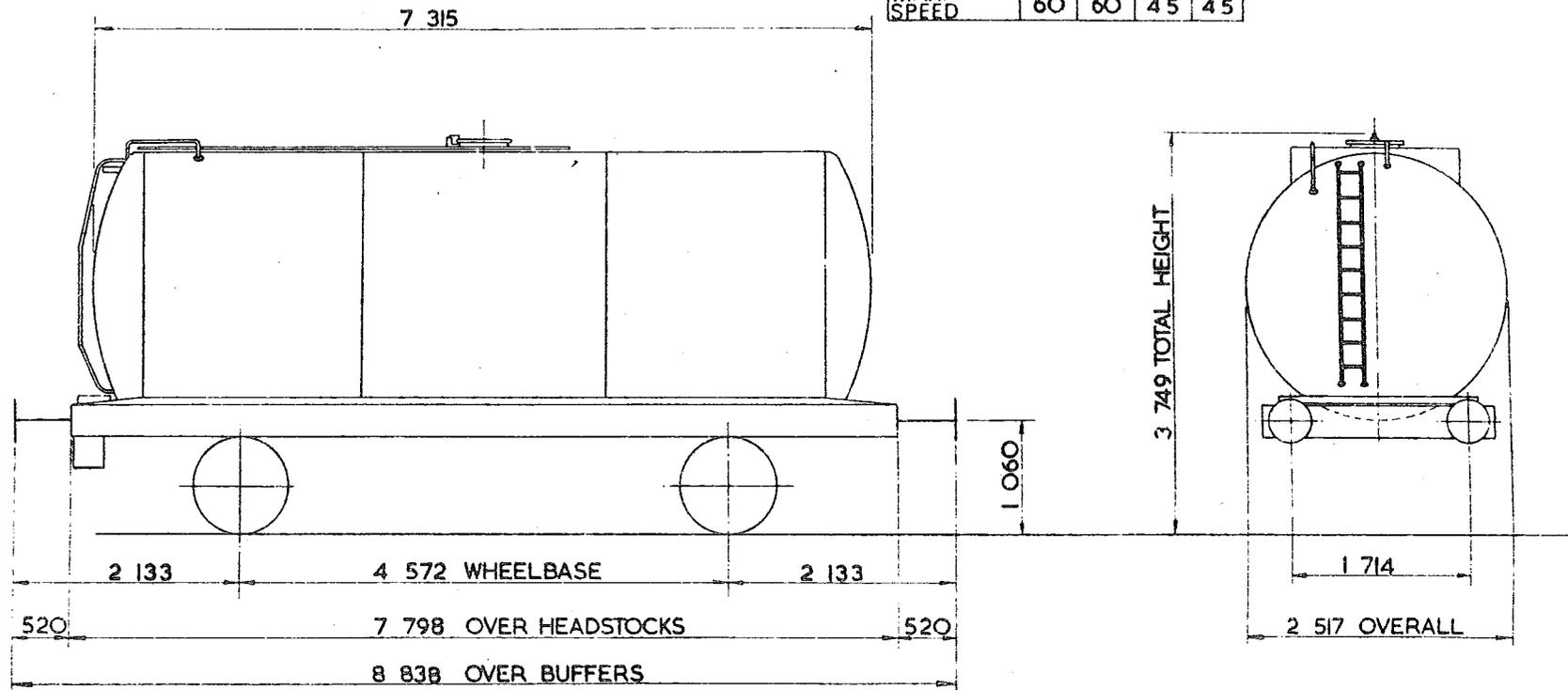

TARE - 10 ⁹⁰⁰ kg
CARRYING CAPACITY - 30 ¹⁰⁰ kg.
CAPACITY - 34336 litres.
MAX. SPEED - 60 mile/h
WHEELS - 952 DIA.
JOURNALS - 140 DIA. ROLLER BEARINGS

BUFFERS - HYDRAULIC 406 DIA. HEADS
COUPLINGS - INSTANTER
MIN. CURVE - 31m.
GEN. ARRGT. DRG. No. -
BRAKE - VACUUM BLOCK & HAND LEVER
SUSPENSION - EYEBOLT

BUILDER - POWELL DUFFRYN
OWNER - ALGECO
REGISTERED BY - C.M.&E.E. (B.R.B.) DERBY
YEAR BUILT - 1964
REGISTRATION Nos. - 49000 TO 49005
OWNERS Nos. - 34 TO 39

ISSUE 2

EX. P.O. DIAGRAM 6/113

41 tonnes G.L.W. TANK WAGON - CLASS A

TTO08B

EXCESS LENGTH	5	H	M	L	E
tonnes	41	41	14	14	
	VB	20	20	7	7
	AB				
	RA	6	6	1	1
MAX SPEED		60	60	45	45

TOPS CODE									
CARKND		AARKND			OPERATING PANEL No.				
T	T	F	T	F	A	1	4	3	0

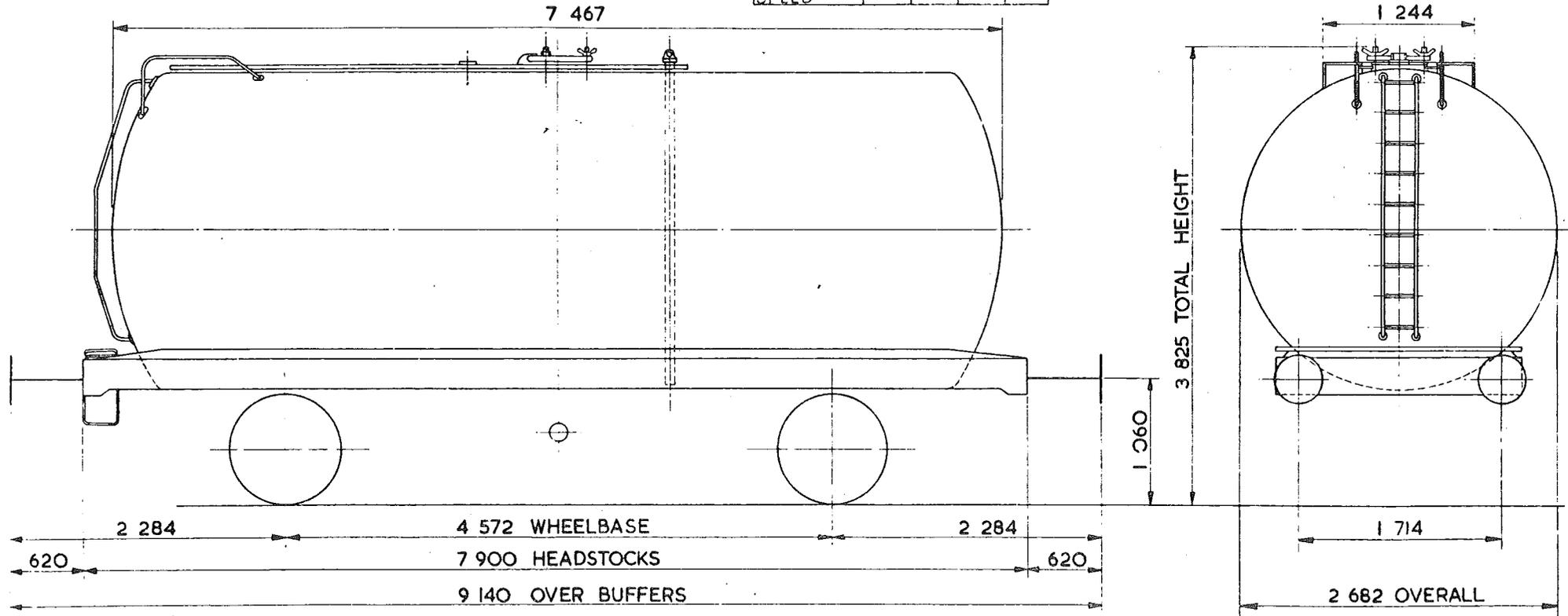

13750 kg
CARRYING CAPACITY - 27200kg
CAPACITY - 39550 litres
MAX SPEED - 60 mile/h
WHEELS - 952 DIA.
AXLES - 140 DIA. ROLLER BEARINGS

BUFFERS - HYDRAULIC 406 DIA. HEADS
COUPLINGS - INTERNATIONAL SCREW
MIN. CURVE - 31m
GEN. ARRGT. DRG. No. -
BRAKE - VACUUM BLOCK & HAND LEVER
SUSPENSION - DOUBLE LINK

BUILDER - POWELL DUFFRYN
OWNER - BRITISH RAILWAY TRAFFIC & ELECTRIC
REGISTERED BY - C.M. & E.E. (B.R.B.) DERBY
YEAR BUILT - 1965
REGISTRATION Nos. - 57295 TO 57305
OWNERS Nos. - 5975 TO 5985

ISSUE 2

EX. P.O. DIAGRAM 6/108

41 tonnes G.L.W. TANK WAGON

TTO08C

EXCESS LENGTH	4	H	M	L	E
tonnes	41	41	13	13	
VB	21	21	8	8	
AB					
RA	6	6	1	1	
MAX SPEED	60	60	45	45	

TOPS CODE										
CARKND		AARKND			OPERATING PANEL No					
T	T	V	T	T	V	A	1	4	3	1

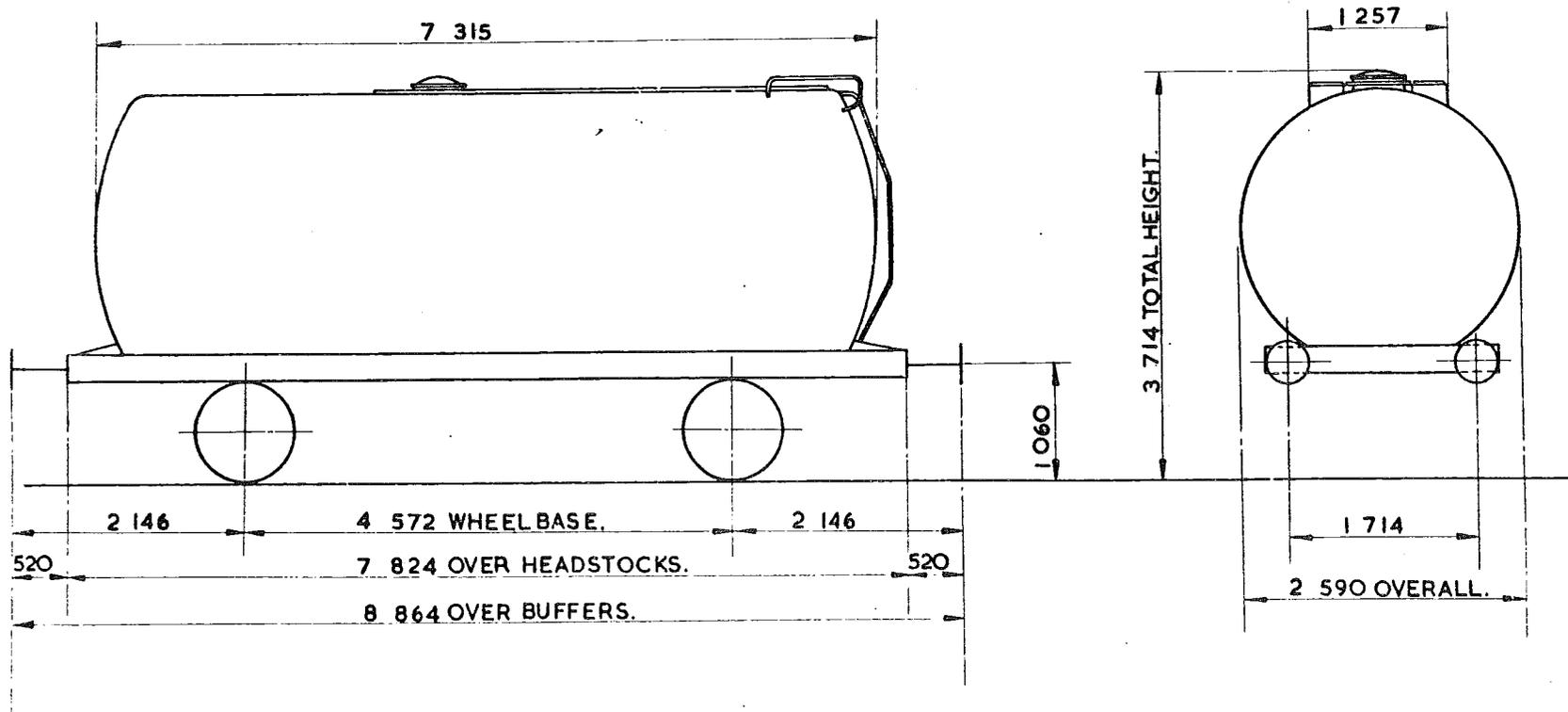

TARE -	12 850 kg.
CARRYING CAPACITY -	28 100 kg.
CAPACITY -	34 731 litres.
MAX. SPEED -	60 mile/h.
WHEELS -	952 DIA.
JOURNALS -	140 DIA. ROLLER BEARINGS.

BUFFERS -	HYDRAULIC 406 DIA. HEADS.
COUPLINGS -	INSTANTER.
MIN. CURVE -	31m.
GEN. ARRGT. DRG. No. -	
BRAKE -	VACUUM BLOCK & HAND LEVER
SUSPENSION -	EYE BOLT.

BUILDER -	CHARLES ROBERTS.
OWNER -	TIGER RAILCAR LEASING.
REGISTERED BY -	C.M.&E.E. (B.R.B.) DERBY.
YEAR BUILT -	1963.
REGISTRATION Nos. -	51281. TO 51298.
OWNERS Nos. -	A 281. TO A298.

ISSUE 2
EX. P.O. DIAGRAM 6/96.

41 tonnes GLW TANK WAGON

TTO09A

EXCESS LENGTH	4	H	M	L	E
tonnes	41	41	11	11	
VB	13	13	4	4	
AB					
RA	6	6	1	1	
MAX. SPEED	60	60	45	45	

TOPS CODE										
CARKND			AARKND			OPERATING PANEL No.				
T	T	V	T	T	V	A	1	2	0	2

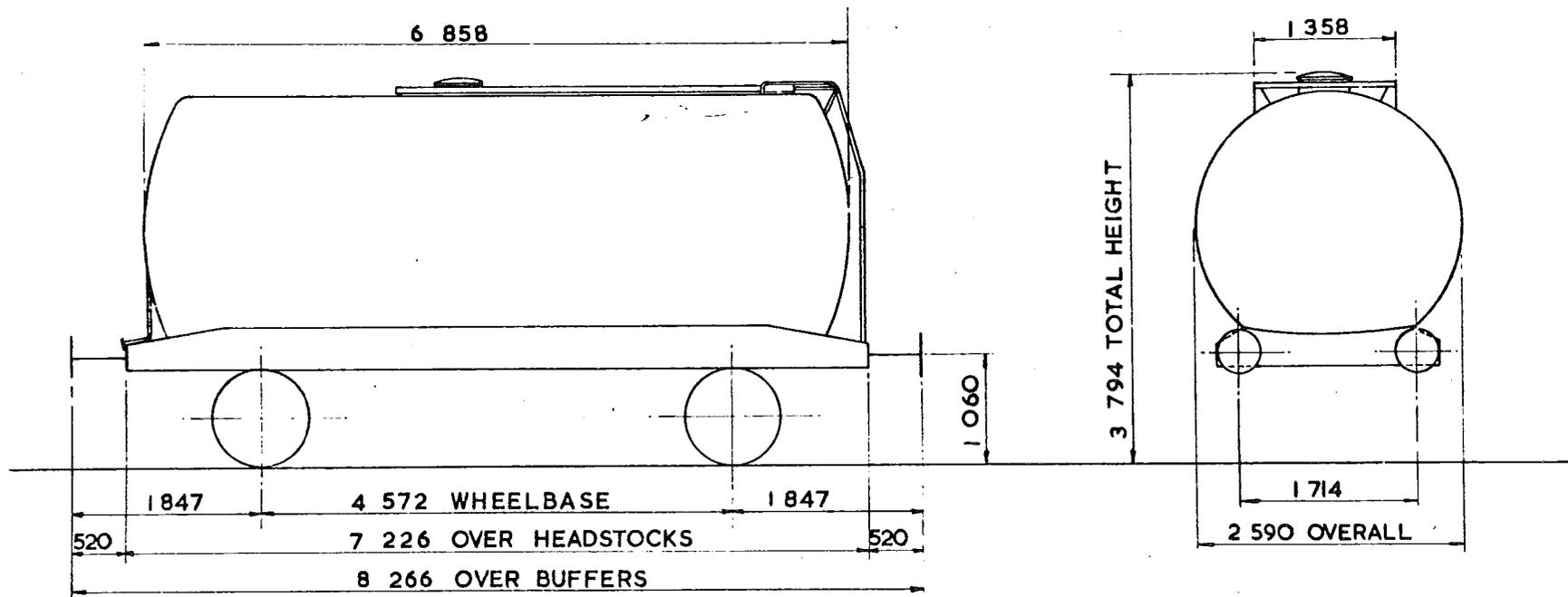

TARE - 10,400 kg.
CARRYING CAPACITY - 30,600 kg.
CAPACITY - 32,731 litres.
MAX. SPEED - 60 mile/h.
WHEELS - 952 DIA.
JOURNALS - 140 DIA. ROLLER BEARINGS

BUFFERS - HYDRAULIC 406 DIA. HEADS
COUPLINGS - INSTANTER
MIN. CURVE - 31m
GEN. ARRGT DRG. No. -
BRAKE - VACUUM BLOCK & HAND LEVER.
SUSPENSION - EYE BOLT

BUILDER - CHARLES ROBERTS
OWNER - TIGER RAILCAR LEASING
REGISTERED BY - C.M. & E.E. (B.R.B.) DERBY.
YEAR BUILT - 1961
REGISTRATION Nos. - 51166
OWNERS Nos. - A166

ISSUE 2

EX. PO. DIAGRAM 6/92

41 tonnes G.L.W. TANK WAGON - ANHYDROUS AMMONIA

TTOIOA

EXCESS LENGTH	7	H	M	L	E
tonnes.	41	41	20	20	
VB	18	18	10	10	
AB					
RA	6	6	1	1	
MAX SPEED	45	45	45	45	

TOPS CODE										
CARKND		AARKND			OPERATING PANEL No					
T	T	F	T	T	F	A	1	4	3	3

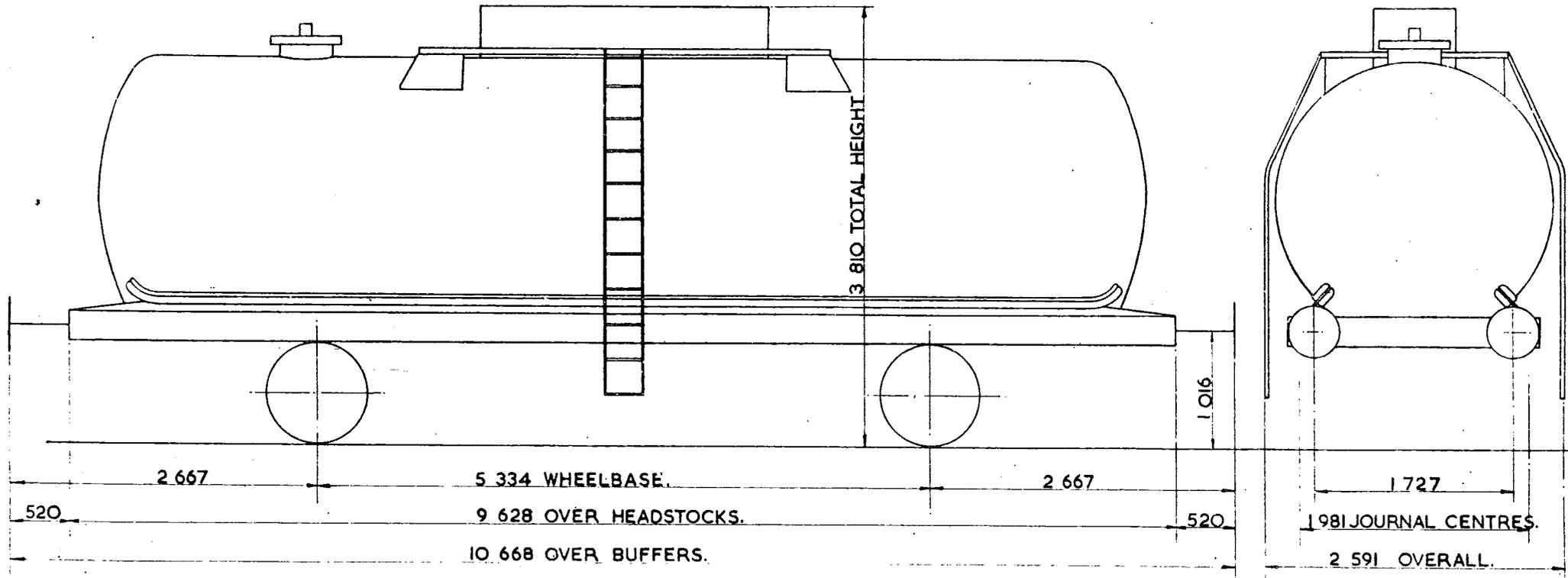

WEIGHT - 20000kg.
CARRYING CAPACITY - 21000kg.
CAPACITY - 36.651m ³
MAX SPEED - 45 mile/h.
WHEELS - 952 DIA.
JOURNALS - 140 DIA. ROLLER BEARINGS.

BUFFERS - HYDRAULIC 457 DIA. HEADS.
COUPLINGS - INSTANTER.
MIN. CURVE - 36m.
GEN. ARRGT DRG No -
BRAKE - VACUUM BLOCK & HAND LEVER.
SUSPENSION - DOUBLE LINK.

BUILDER - METRO CAMELL.
OWNER - STS.
REGISTERED BY - C.M & E.E. (B.R.B) DERBY.
YEAR BUILT - 1965.
REGISTRATION Nos - 53250-53264.
OWNERS Nos - 2050-2064.

ISSUE 2

EX. PO. DIAGRAM 6/751 (ALLOCATED)

41 tonnes G.L.W. TANK - ANHYDROUS AMMONIA

TTOIOB

EXCESS LENGTH	7	H	M	L	E
tonnes	41	41	20	20	
VB	18	18	11	11	
AB					
RA	6	6	1	1	
MAX SPEED	45	45	45	45	

TOPS CODE										
CARKND		AARKND		OPERATING PANEL No						
T	T	V	T	T	V	A	1	2	4	6

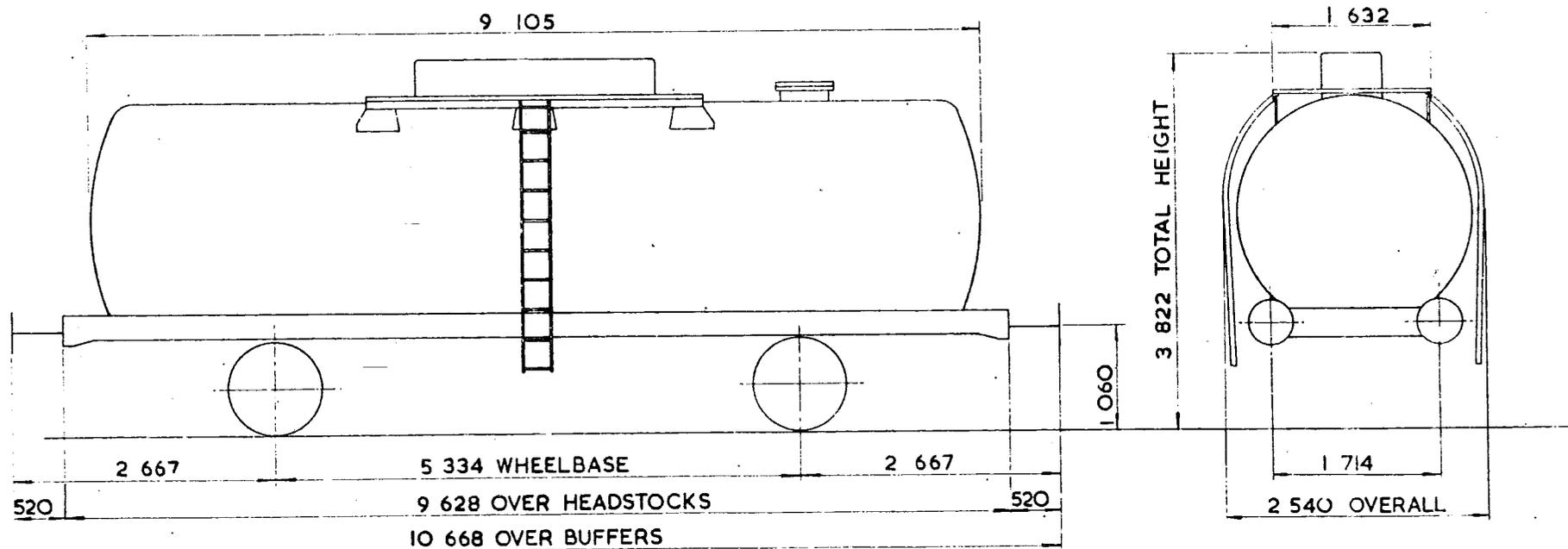

TARE 20 050 kg.
CARRYING CAPACITY - 20 900 kg.
CAPACITY - 37 627 litres.
MAX SPEED 45 mile/h.
WHEELS 952 DIA.
JOURNALS 140 DIA. ROLLER BEARINGS

BUFFERS - HYDRAULIC 457 DIA. HEADS
COUPLINGS INSTANTER
MIN. CURVE 36m.
GEN. ARRGT DRG No
BRAKE VACUUM BLOCK & HAND LEVER.
SUSPENSION DOUBLE LINK

BUILDER CHARLES ROBERTS
OWNER TIGER RAILCAR LEASING
REGISTERED BY C.M. & EE (B.R.B.) DERBY
YEAR BUILT - 1965/66
REGISTRATION Nos. TRL 51450 TO 51538
OWNERS Nos. A450 TO A538

ISSUE 2
EX PO. DIAGRAM 6/98

41 tonnes G.L.W. TANK WAGON - ANHYDROUS AMMONIA

TT 010 C

EXCESS LENGTH	H	M	L	E
tonnes	41	41	20	20
VB	18	18	11	11
AB				
RA	6	6	1	1
MAX. SPEED	45	45	45	45

TOPS CODE										
CARKND		AARKND			OPERATING PANEL No.					
T	T	V	T	T	V	A	1	2	4	6

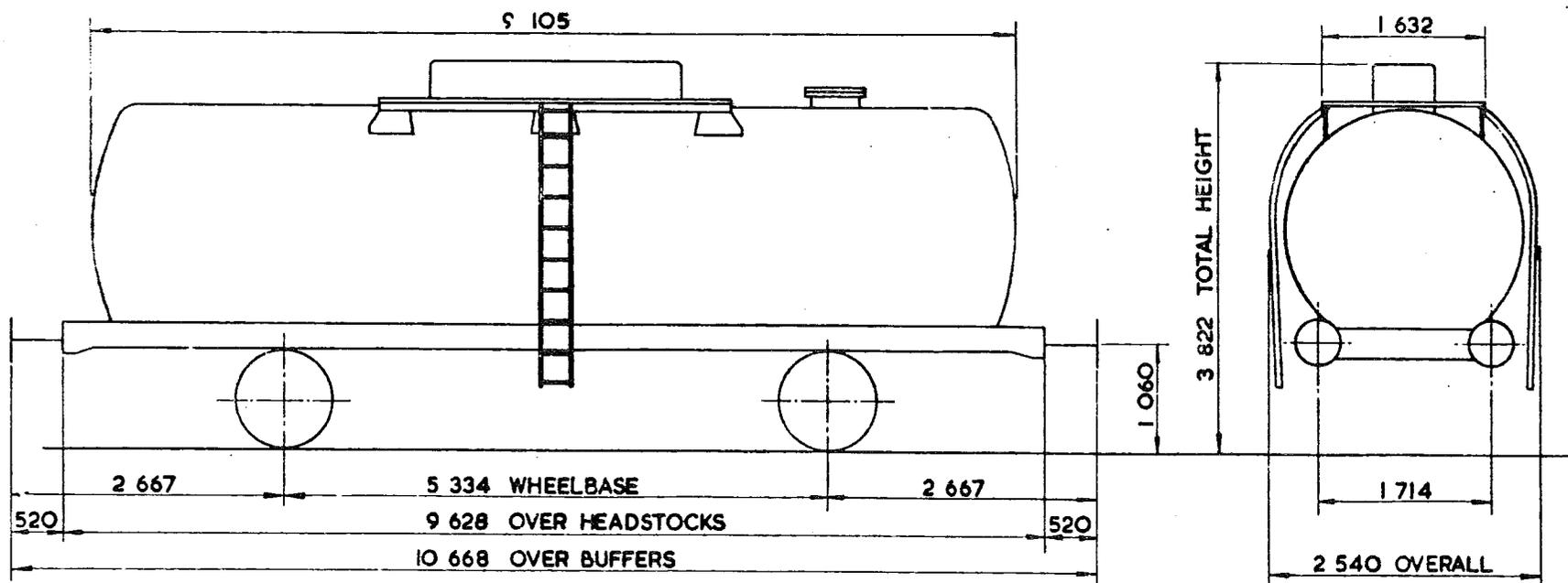

TARE-	20 050 kg
CARRYING CAPACITY-	20 900 kg
CAPACITY-	37 627 litres
MAX. SPEED-	45 mile/h
WHEELS-	952 DIA.
JOURNALS-	140 DIA. ROLLER BEARINGS

BUFFERS-	HYDRAULIC 457 DIA. HEADS
COUPLINGS-	INSTANTER
MIN. CURVE-	36 m.
GEN. ARRGT. DRG. No.-	
BRAKE-	VACUUM BLOCK & HAND LEVER
SUSPENSION-	DOUBLE LINK

BUILDER-	CHARLES ROBERTS
OWNER-	I.C.I. (AGRICULTURAL)
REGISTERED BY-	C.M. & E.E. (B.R.B.) DERBY
YEAR BUILT-	1965/66
REGISTRATION Nos.-	54301 - 54350
OWNERS Nos.-	A 450 TO A 538

ISSUE 2
EX. P.O. DIAGRAM 6/98

41 tonne G.L.W. ANHYDROUS AMONIA TANK WAGON

TT010D

EXCESS LENGTH	7	H	M	L	E
tonnes	41	41	18	18	
VB	18	18	11	11	
AB					
RA	6	6	1	1	
MAX SPEED	60	60	60	60	

TOPS CODE										
CARKND		AARKND			OPERATING PANEL No.					
T	T	F	T	T	F	A	1	5	9	4

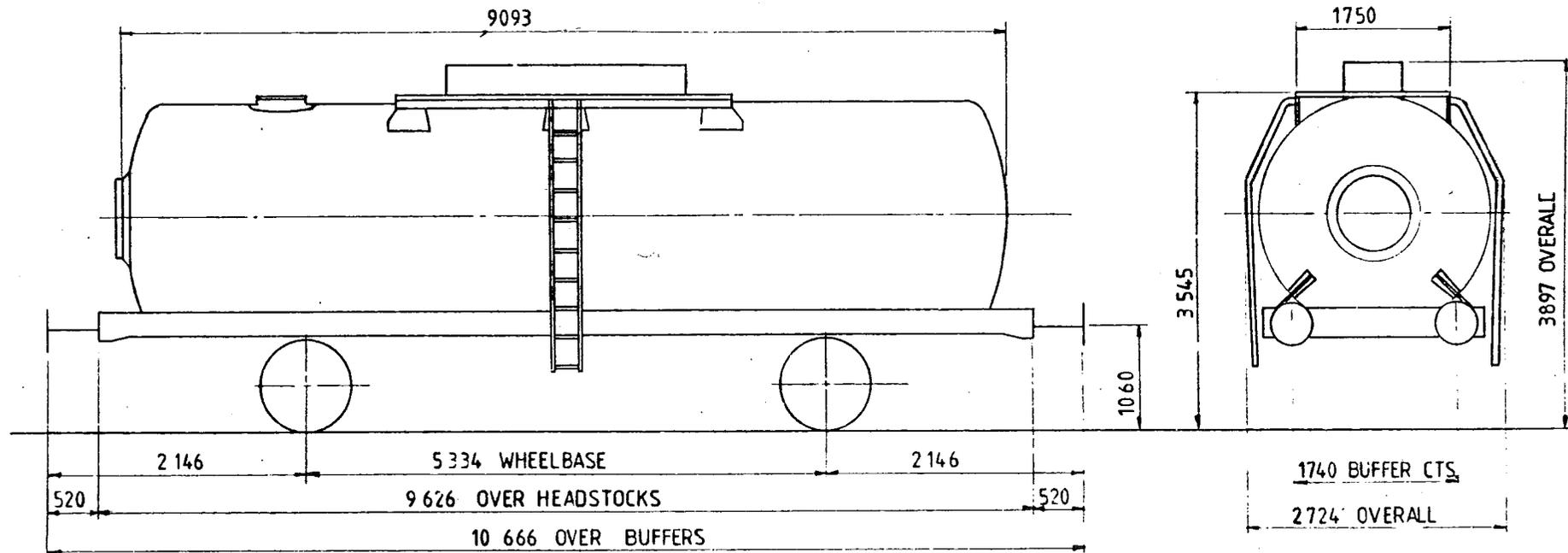

TARE	20050 kg
CARRYING CAPACITY	20900 kg
CAPACITY	42002 litres
MAX SPEED	60 mile/h
WHEELS	952 DIA
JOURNALS	140 DIA ROLLER BEARINGS

BUFFERS	HYDRAULIC 406 DIA HEADS
COUPLINGS	INSTANTER
MIN CURVE	36m SINGLY & CLOSE COUPLED
GEN ARRGT DRG No	
BRAKE	VACUUM BLOCK & HAND LEVER
SUSPENSION	BSC FRICTION PEDESTAL

ISSUE 1

41 tonnes GLW TANK WAGON

TTOI2A

EXCESS LENGTH	4	H	M	L	E
tonnes	41	41	16	16	
VB	21	21	10	10	
AB					
RA	6	6	1	1	
MAX SPEED	60	60	45	45	

TOPS CODE										
CARKND		AARKND			OPERATING PANEL No					
T	T	V	T	T	V	A	1	4	3	4

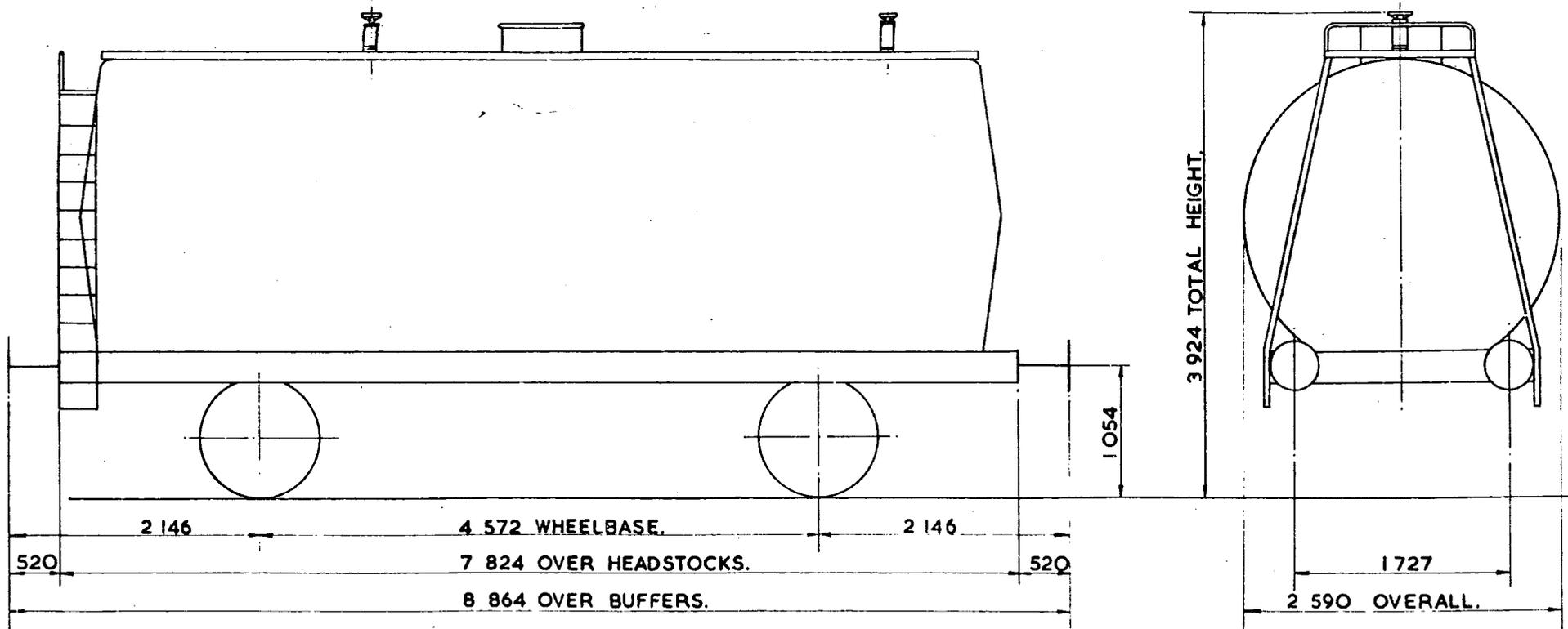

TARE - 15600kg.
CARRYING CAPACITY - 25400kg.
CAPACITY - 261es litres.
MAX. SPEED - 60 mile/h.
WHEELS - 952 DIA.
JOURNALS - 140 DIA. ROLLER BEARINGS.

BUFFERS - HYDRAULIC 406 DIA. HEADS.
COUPLINGS - INSTANTER
MIN. CURVE - 31m.
GEN. ARRGT. DRG. No. -
BRAKE - VACUUM BLOCK & HAND LEVER
SUSPENSION - EYEBOLT & AUXILIARY RUBBERS.

BUILDER - POWELL DUFFRYN.
OWNER - SUKO
REGISTERED BY C.M. & E.E. (B.R.B.) DERBY.
YEAR BUILT - 1963
REGISTRATION Nos. - 52155-52159, 52200-52229
OWNERS Nos. -

ISSUE 2

EX. PO. DIAGRAM 6/730(ALLOCATED.)

41 tonne GLW TANK WAGON

TT 012 C

EXCESS LENGTH	4	H	M	L	E
tonnes	41	41	17	17	
VB					
AB	25	25	12	12	
RA	6	6	1	1	
MAX SPEED	60	60	45	45	

TOPS CODE					
CARKND	AARKND		OPERATING PANEL No.		
T	T	A	T	A	A 1 4 6 1

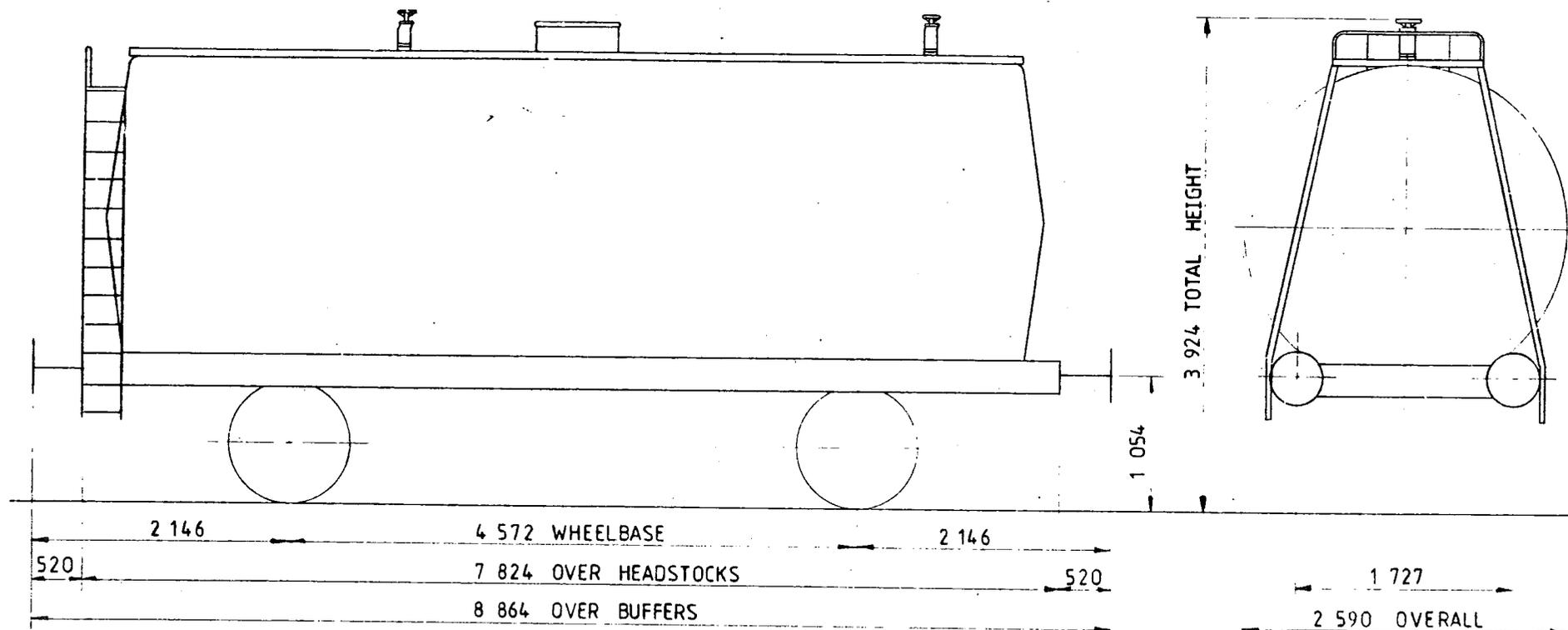

TARE -	16 150 kg
CARRYING CAPACITY -	24 800 kg
CAPACITY -	25 603 litres
MAX SPEED -	60 mile/h
WHEELS -	952 DIA.
JOURNALS -	140 DIA ROLLER BEARINGS

BUFFERS	HYDRAULIC 406 DIA HEAD
COUPLINGS	INSTANTER
MIN CURVE	31 m
GEN ARRGT DRG No	
BRAKE	AIR BLOCK & HAND LEVER
SUSPENSION	EYEBOLT & AUXILIARY RUBBERS

ISSUE 1

41 tonnes G.L.W. TANK WAGON - BITUMEN

TTOI3B

	4	4	M	L	E
tonnes.	41	41	14	14	
	21	21	9	9	
	6	6	1	1	
	60	60	45	45	

TOPS CODE	
BARND	BARND
TTVTTVA1435	

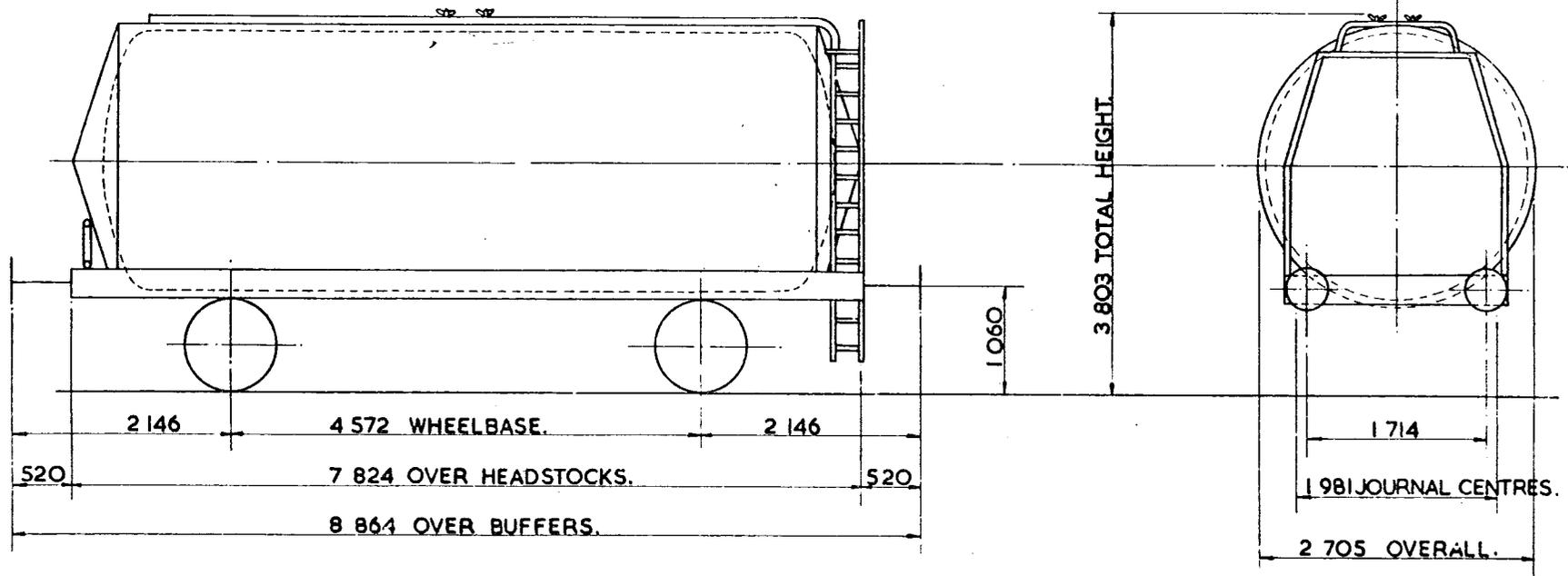

14000kg
 CARRYING CAPACITY - 27000kg.
 CAPACITY - 31022 litres.
 60 mile/h.
 952 DIA.
 140 DIA. ROLLER BEARINGS.

HYDRAULIC 406 DIA. HEADS.
 INSTANTER
 31m.
 VACUUM BLOCK & HAND LEVER.
 EYE BOLT.

LEAF	POWELL DUFFRYN.
PLATE	SUKO
REASSEMBLED BY	C.M. & E.E. (B.R.B) DERBY.
YEAR BUILT	1963/1964.
REGISTRATION NO.	50500
OWNERS NPS	

ISSUE 2

EX. P.C. DIAGRAM 6/728 (ALLOCATED)

41 tonnes G.L.W. TANK WAGON

TT013C

EXCESS LENGTH	4	H	M	L	E
tonnes	41	41	16	16	
VB	18	18	8	8	
AB					
RA	6	6	1	1	
MAX SPEED	60	60	45	45	

TOPS CODE	
CARKND	AARKND
T T V T T V A	1 2 8 5

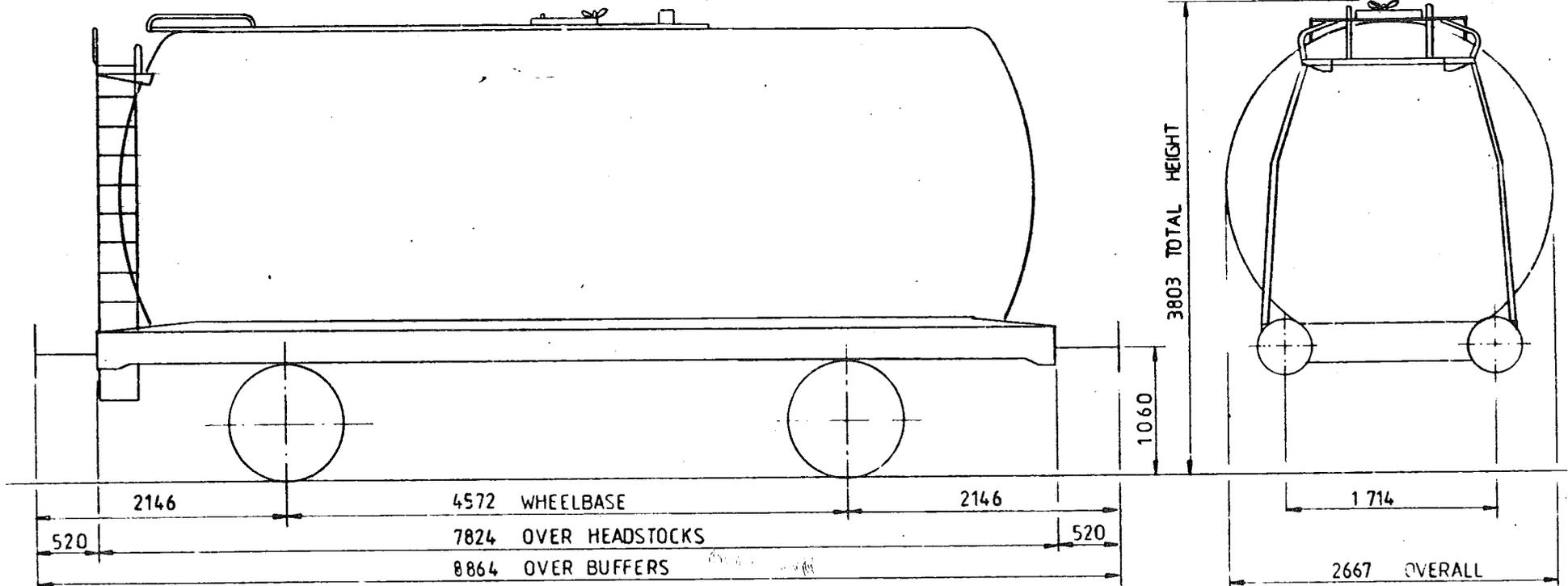

TARE	16 000 kg
CARRYING CAPACITY -	25 000 kg
CAPACITY -	31628 Litres
MAX SPEED	60 mile/h
WHEELS	φ 952
JOURNALS	φ140 ROLLER BEARINGS

BUFFERS	HYDRAULIC φ406 HEADS
COUPLINGS	INSTANTER
MIN CURVE	31 m
GEN ARRGT DRG No	
BRAKE	VACUUM BLOCK, HAND LEVER
SUSPENSION	EYEBOLT

ISSUE 1

EX PO DIAGRAM 61/23

41 tonnes G.L.W TANK WAGON

TTO14A

EXCESS LENGTH	4	H	M	L	E
tonnes	41	41	15	15	
VB	18	18	8	8	
AB					
RA	6	6	1	1	
MAX. SPEED	60	60	45	45	

TOPS CODE										
CARKND		AARKND		OPERATING PANEL No.						
T	T	V	T	T	V	A	1	2	8	1

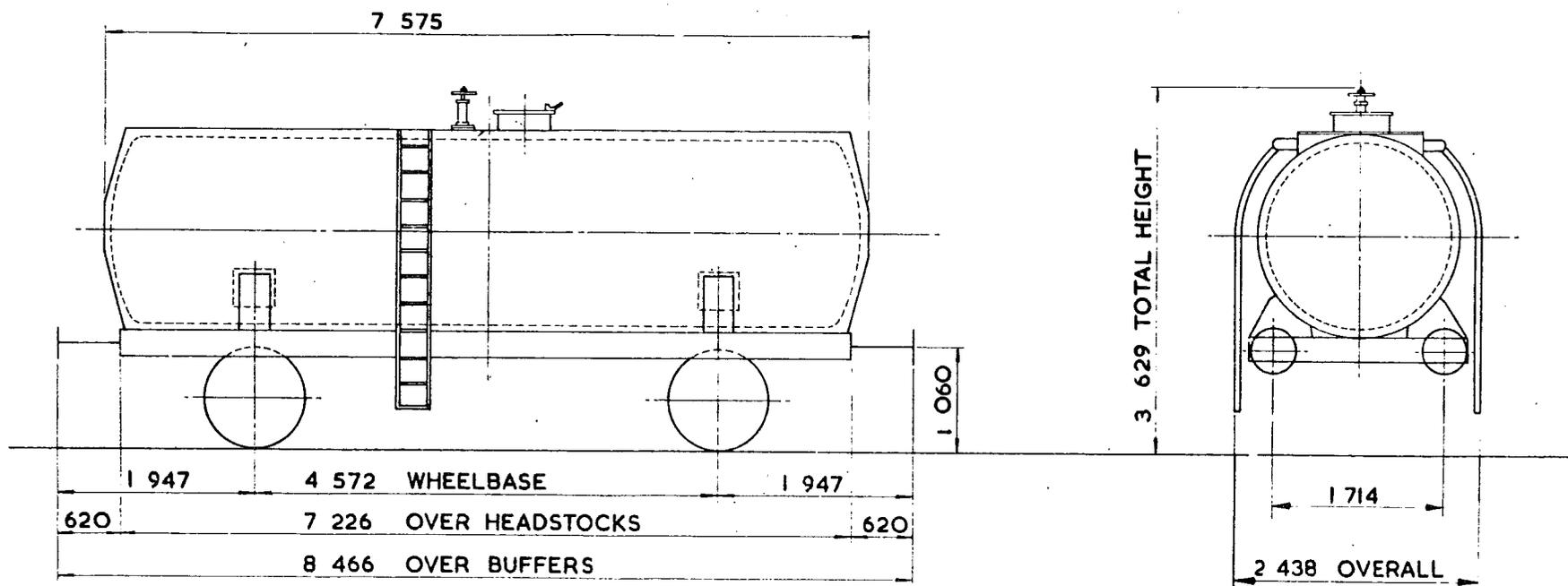

TARE - 14 750 kg
CARRYING CAPACITY - 26 200 kg
CAPACITY - 9 025 litres
MAX. SPEED - 60 mile/h
WHEELS - 1000 DIA.
JOURNALS - 130 DIA. ROLLER BEARINGS

BUFFERS - HYDRAULIC 406 DIA. HEADS
COUPLINGS - INTERNATIONAL SCREW
MIN. CURVE - 31 m
GEN ARRGT. DRG. No. -
BRAKE - VACUUM BLOCK & HAND LEVER
SUSPENSION - DOUBLE LINK

BUILDER - CHARLES ROBERTS
OWNER - FISON'S LTD.
REGISTERED BY - C.M.&E.E. (B.R.B.) DERBY
YEAR BUILT - 1965
REGISTRATION Nos. - 55408 TO 55412
OWNERS Nos. - M12/48 TO M12/52

ISSUE 2
EX P.O. DIAGRAM 6/85

41 tonnes G.L.W. TANK WAGON

TTO15A

EXCESS LENGTH	H	M	L	E
4				
tonnes	41	41	16	16
VB	15	15	9	9
AB				
RA	6	6	1	1
MAX. SPEED	60	60	45	45

TOPS CODE					
CARKND	AARKND	OPERATING PANEL No			
T	T	V	T	T	V A
					1 4 3 6

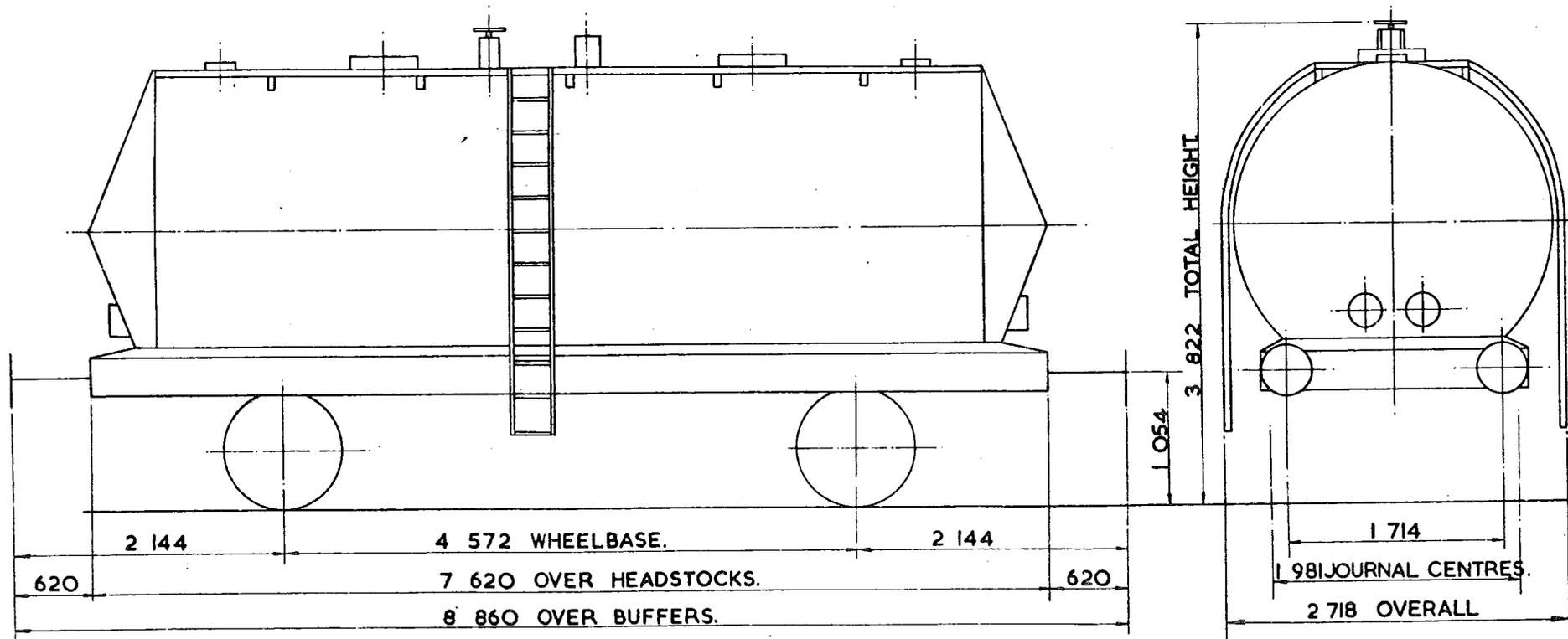

TARE - 16 ²⁵⁰ kg.
CARRYING CAPACITY - 24 ⁷⁰⁰ kg.
CAPACITY - 27 ¹³⁹ litres
MAX SPEED - 60 mile/h.
WHEELS - 952 DIA.
JOURNALS - 140 DIA. ROLLER BEARINGS.

BUFFERS - HYDRAULIC 406 DIA. HEADS
COUPLINGS - INSTANTER.
MIN. CURVE - 31m.
GEN. ARRG. DRG. No. -
BRAKE - VACUUM BLOCK & HAND LEVER
SUSPENSION - EYEBOLT.

BUILDER - POWELL DUFFRYN.
OWNER - POWELL DUFFRYN.
REGISTERED BY - C.M. & E.E.(B.R.B.) DERBY.
YEAR BUILT - 1961.
REGISTRATION Nos. - 52000 - 52027.
OWNERS Nos. - 9000 - 9027.

ISSUE 2
EX. P.O. DIAGRAM 6/687 (ALLOCATED)

41 tonnes GLW TANK WAGON

TTO16A

EXCESS LENGTH S	H	M	L	E
tonnes	41	41	16	16
VB	21	21	10	10
AB				
RA	6	6	1	1
MAX. SPEED	60	60	45	45

TOPS CODE		
CARKND	AARKND	OPERATING PANEL No
T	V	A
T	T	V
A	1	4
	3	7

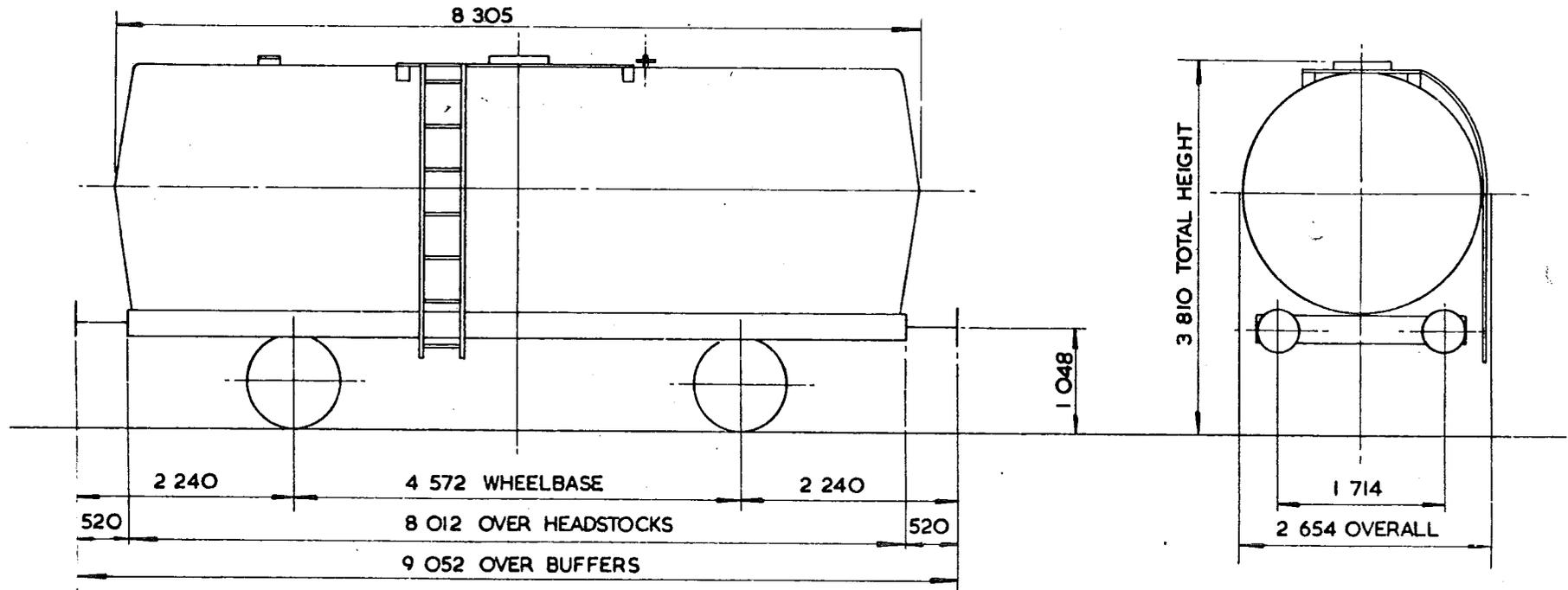

TARE--	16000kg
CARRYING CAPACITY--	25000kg
CAPACITY--	
MAX. SPEED--	60mile/h
WHEELS--	952 DIA
JOURNALS--	140DIA. ROLLER BEARINGS

BUFFERS--	HYDRAULIC 406 DIA. HEADS
COUPLINGS--	INSTANTER
MIN. CURVE--	31m
GEN. ARRGT. DRG. No	
BRAKE--	VACUUM BLOCK & HAND LEVER
SUSPENSION--	EYEBOLT & AUXILIARY RUBBERS

BUILDEP--	POWELL DUFYRN
OWNER--	SUKO
REGISTERED BY--	C.M.&E.E.(B.R.B.) DERBY
YEAR BUILT--	1962
REGISTRATION Nos.--	52100 TO 52154 (RANGE)
OWNERS Nos.--	

ISSUE 2

EX. P.O. DIAGRAM 6/729(ALLOCATED)

46 tonnes G.L.W. TANK WAGON - LIQUEFIED PETROLEUM GAS

TTO17A

EXCESS LENGTH	5	H	M	L	E
tonnes	46	46	22	22	
VB	18	18	10	10	
AB					
RA	7	6	1	1	
MAX. SPEED	60	60	45	45	

TOPS CODE										
CARKND			AARKND			OPERATING PANEL No.				
T	T	F	T	T	F	A	1	4	3	8

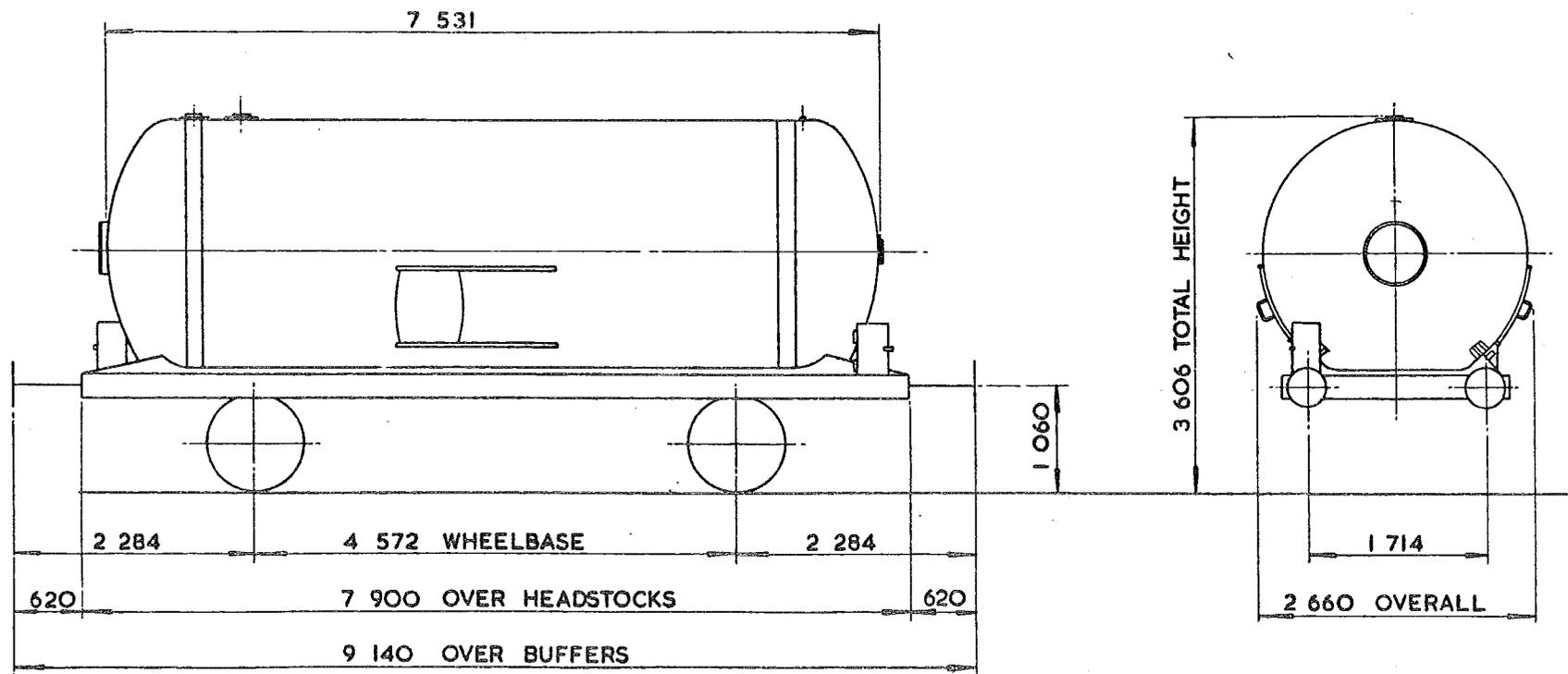

TARE -	22 250 kg
CARRYING CAPACITY -	23 700 kg
CAPACITY	35 495 litres
MAX. SPEED -	60 mile/h
WHEELS -	952 DIA.
JOURNALS -	140 DIA. ROLLER BEARINGS

BUFFERS -	HYDRAULIC 406 DIA. HEADS
COUPLINGS -	INTERNATIONAL SCREW
MIN. CURVE -	31 m
GEN. ARRGT. DRG. No. -	
BRAKE -	VACUUM BLOCK & HAND LEVER
SUSPENSION -	EYEBOLT & AUXILIARY RUBBERS

BUILDER -	POWELL DUFFRYN
OWNER -	ESSO
REGISTERED BY -	C.M. & E.E. (B.R.B.) DERBY
YEAR BUILT -	1963
REGISTRATION Nos. -	56341 TO 56356 (RANGE)
OWNERS Nos. -	41 TO 56 (RANGE)

ISSUE 3.

EX PO. DIAGRAM 6/124

46 tonnes G.L.W. TANK-LIQUEFIED PETROLEUM GAS

TTO17B

EXCESS LENGTH	5	H	M	L	E
tonnes	46	46	23	23	
VB	18	18	10	10	
AB					
RA	7	6	1	1	
MAX. SPEED	60	60	45	45	

TOPS CODE										
CARKND		AARKND			OPERATING PANEL No					
T	T	F	T	T	F	A	1	4	3	9

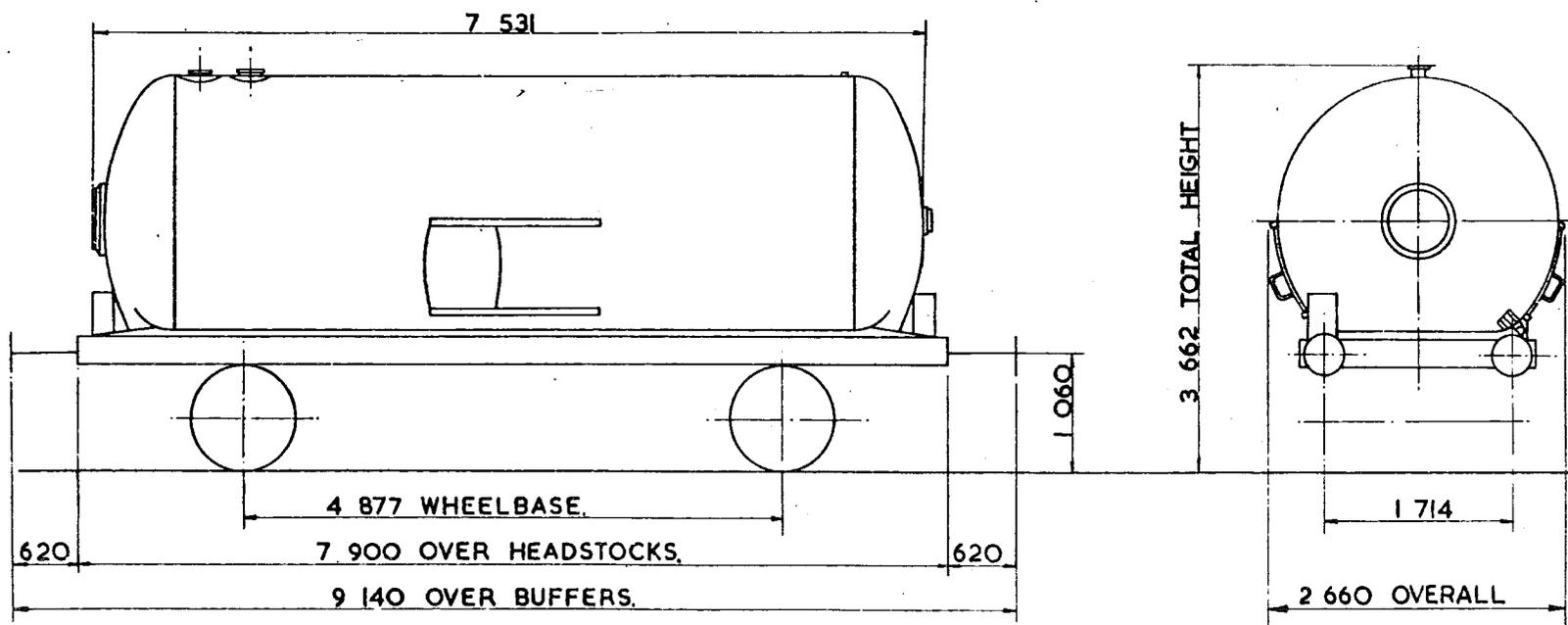

TARE - 23 000 kg.
CARRYING CAPACITY - 22 900 kg
CAPACITY - 35 495 litres
MAX. SPEED - 60 mile/h.
WHEELS - 952 DIA.
JOURNALS - 140 DIA. ROLLER BEARINGS.

BUFFERS - HYDRAULIC 406 DIA. HEADS
COUPLINGS - INTERNATIONAL SCREW.
MIN. CURVE - 31m.
GEN. ARRGT. DRG. No. -
BRAKE - VACUUM BLOCK & HAND LEVER
SUSPENSION - DOUBLE LINK.

BUILDER - POWELL DUFFRYN
OWNER - ESSO.
REGISTERED BY - C.M. & E.E. (B.R.B) DERBY.
YEAR BUILT - 1965.
REGISTRATION Nos. - 56343 TO 56373 (RANGE)
OWNERS Nos. - 43 TO 73 (RANGE)

ISSUE 2

EX. P.O. DIAGRAM 6/91

46 GL.W. TANK WAGON - LIQUEFIED PETROLEUM GAS

TTO17C

EXCESS LENGTH	5	H	M	L	E
tonnes	46	46	22	22	
VB	18	18	10	10	
AB					
RA	7	6	1	1	
MAX. SPEED	60	60	45	45	

TOPS CODE										
CARKND			AARKND			OPERATING PANEL No				
T	T	F	T	T	F	A	1	4	3	8

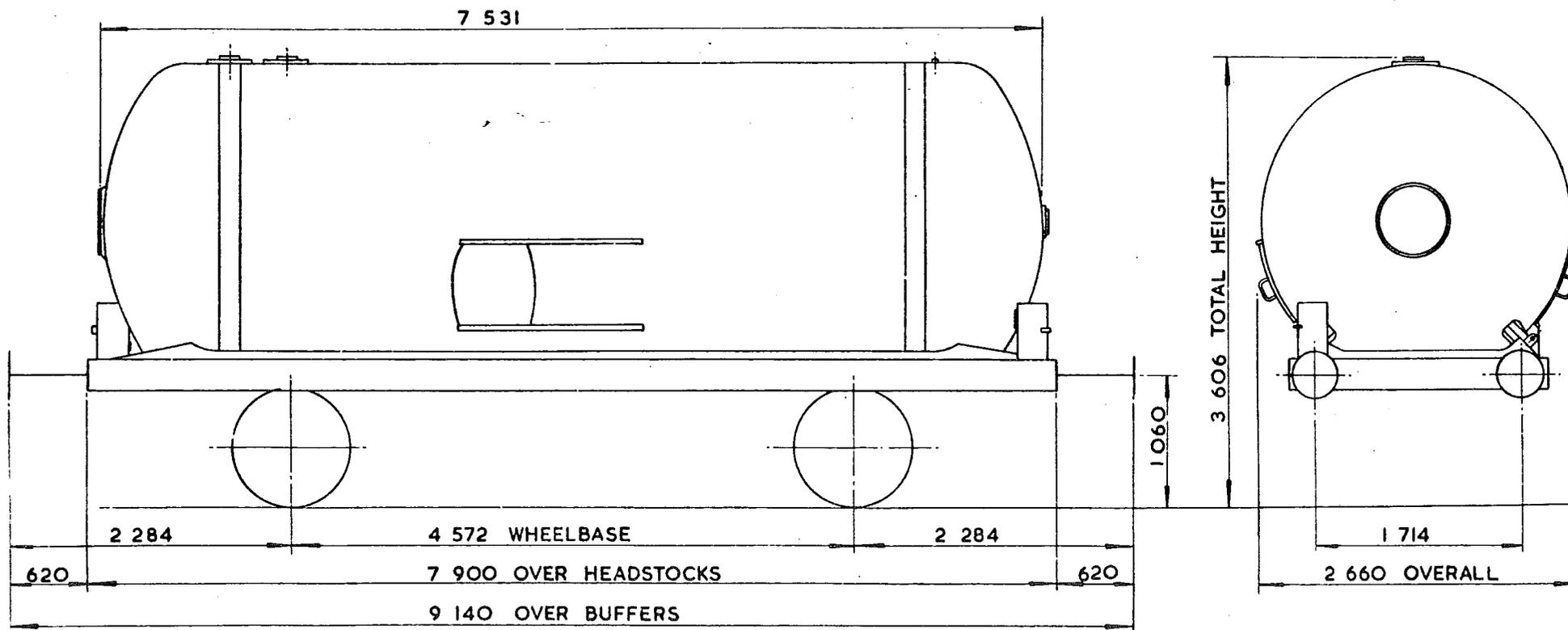

TARE - 21750 kg
CARRYING CAPACITY - 24250 kg
CAPACITY - 35495 litres
MAX. SPEED - 60 mile/h
WHEELS - 952 DIA.
JOURNALS - 140 DIA. ROLLER BEARINGS

BUFFERS - HYDRAULIC 406 DIA. HEADS
COUPLINGS - INTERNATIONAL SCREW
MIN. CURVE - 31m
GEN. ARRGT. DRG. No. -
BRAKE - VACUUM BLOCK & HAND LEVER
SUSPENSION - EYEBOLT

BUILDER - POWELL DUFFRYN
OWNER - ESSO
REGISTERED BY - C.M. & E.E.(B.R.B.) DERBY
YEAR BUILT - 1964
REGISTRATION Nos. - 56363 TO 56374 (RANGE)
OWNERS Nos. - 63 TO 74 (RANGE)

ISSUE 2
EX P.O. DIAGRAM 6/125

46 tonnes G.L.W. TANK-LIQUEFIED PETROLEUM GAS

TTO17D

EXCESS LENGTH	5	H	M	L	E
tonnes	46	46	22	22	
VB	18	18	10	10	
AB					
RA	7	6	1	1	
MAX SPEED	60	60	45	45	

TOPS CODE										
CARKND			AARKND			OPERATING PANEL N.				
T	T	F	T	T	F	A	1	4	3	8

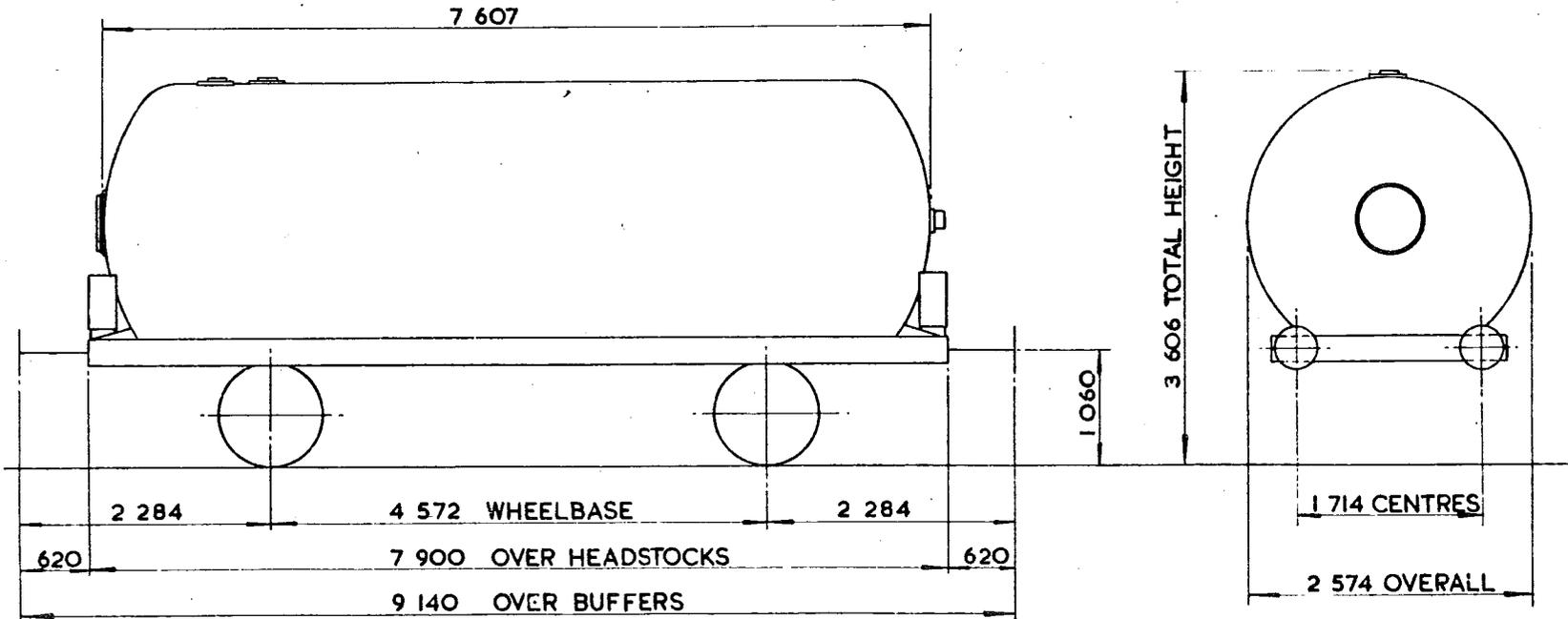

TARE - 23 100 kg
CARRYING CAPACITY - 22 900 kg
CAPACITY - 35 558 litres
MAX SPEED - 60 mile/h
WHEELS - 952 DIA.
JOURNALS - 140 DIA. ROLLER BEARINGS

BUFFERS - HYDRAULIC 406 DIA. HEADS
COUPLINGS - INTERNATIONAL SCREW
MIN CURVE - 31 m
GEN. ARRGT DRG. No -
BRAKE - VACUUM BLOCK & HAND LEVER
SUSPENSION - EYEBOLT

BUILDER - CHARLES ROBERTS
OWNER - ESSO
REGISTERED BY - C.M. & E.E. (B.R.B.) DERBY
YEAR BUILT - 1964
REGISTRATION Nos. - 56375 TO 56384
OWNERS Nos. - 75 TO 84

ISSUE 2
EX P.O. DIAGRAM 6/90

46 tonne GLW TANK WAGON L.P.G.

LOT NUMBER	

TOPS INFORMATION										
AARKND		OPERATING PANEL No.		OPERATING SPEED		BRAKE FORCE DATA		EXCESS LENGTH	RA (GLW)	DESIGN SHEET
CARKND		T T A A		60 mile/h UP TO mile/h ABOVE		46 tonne GLW		9t FORCE UP TO 24t FORCE ABOVE		30.5 tonne GLW
								5	9	W1037

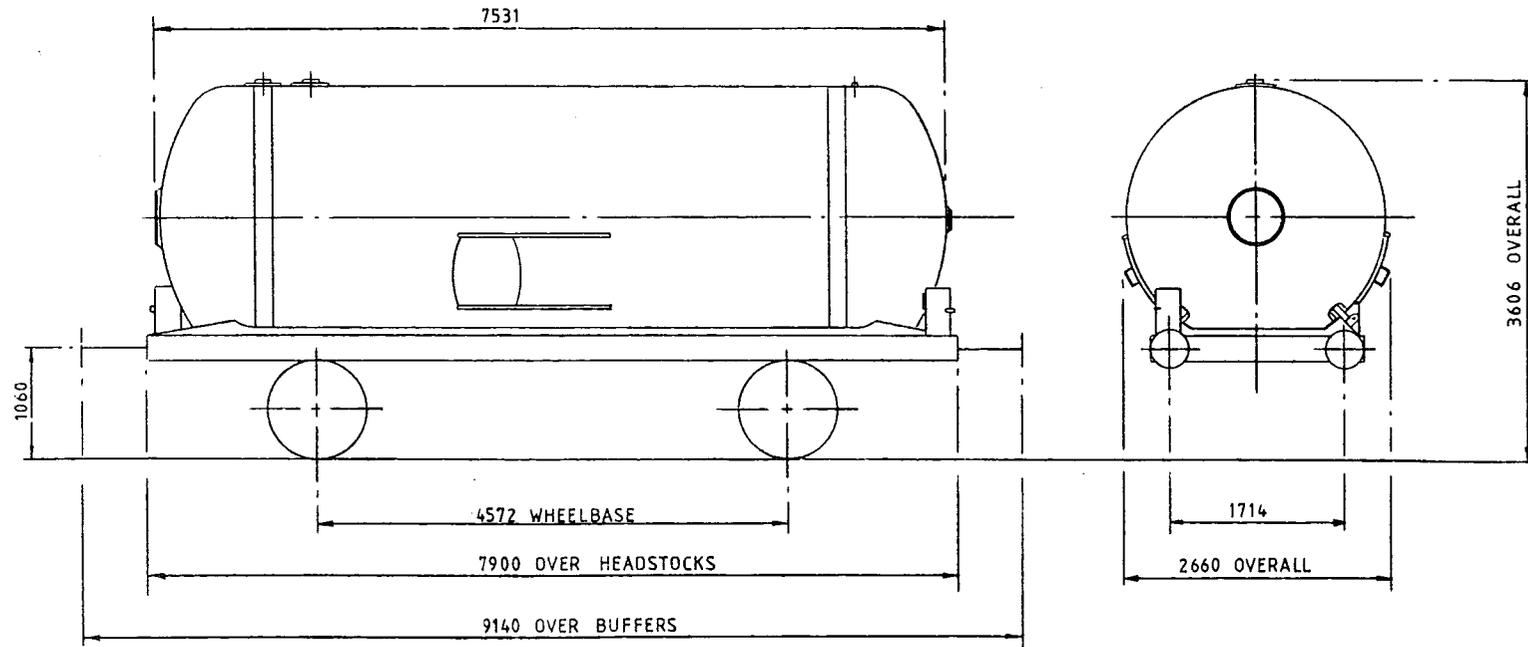

TARE-	23,300 Kg
CAPACITY, WEIGHT-	22,700 Kg
CAPACITY, VOLUME-	35,495 litres
MIN. CURVE-	31 m
GEN. ARRGT. DRG. NO.-	

BRAKE-	AIR BLOCK & HAND LEVER
SUSPENSION-	DOUBLE LINK & PARABOLIC SPRING
COUPLINGS-	INTERNATIONAL SCREW
BUFFERS-	HYDRAULIC 406 DIA HEADS
WHEELS-	952 DIA
JOURNALS-	140 DIA ROLLER BEARINGS

ISSUE 1

46tonne GLW TANK WAGON L.P.G.

LOT NUMBER	

TOPS INFORMATION						
AARKND	OPERATING	OPERATING SPEED		BRAKE FORCE DATA		EXCESS LENGTH
CARKND	PANEL No.	60 mile/h UP TO	46 tonne GLW	9 t FORCE UP TO	30.5 tonne GLW	RA (GLW)
T T A A		mile/h ABOVE		24 t FORCE ABOVE		5
						7
						DESIGN SHEET
						W1038

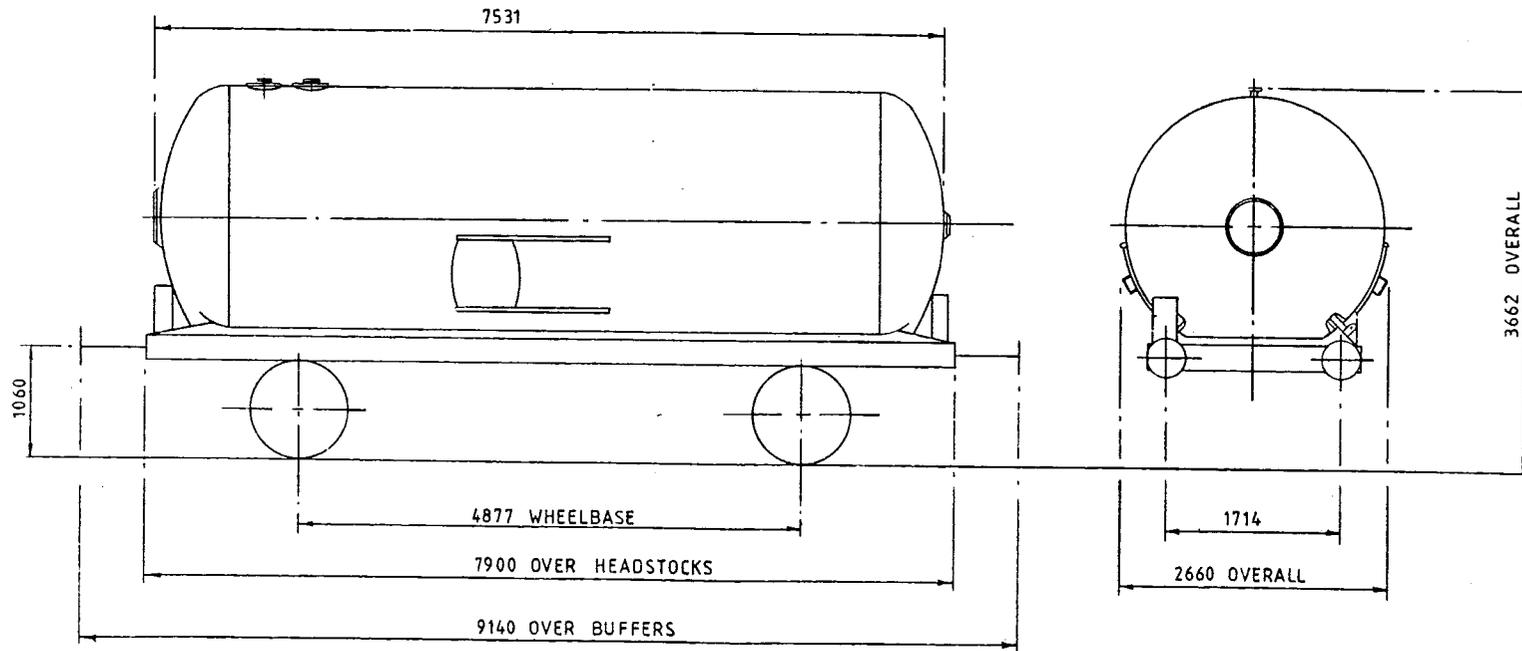

TARE-	23,300 Kg
CAPACITY, WEIGHT-	22,700 Kg
CAPACITY, VOLUME-	35,495 litres
MIN. CURVE-	31 m
GEN. ARRGT. DRG. NO.-	

BRAKE-	AIR BLOCK & HAND LEVER
SUSPENSION-	DOUBLE LINK & PARABOLIC SPRING
COUPLINGS-	INTERNATIONAL SCREW
BUFFERS-	HYDRAULIC 406 DIA HEADS
WHEELS-	952 DIA
JOURNALS-	140 DIA ROLLER BEARINGS

ISSUE 1

46tonne GLW TANK WAGON L.P.G.

LOT NUMBER	

TOPS INFORMATION						
AARKND	OPERATING	OPERATING SPEED		BRAKE FORCE DATA		EXCESS LENGTH
CARKND	PANEL No.	60 mile/h UP TO	46 tonne GLW	9 t FORCE UP TO	30.5 tonne GLW	RA (GLW)
T T A A		mile/h ABOVE		24 t FORCE ABOVE		DESIGN SHEET
						W1039

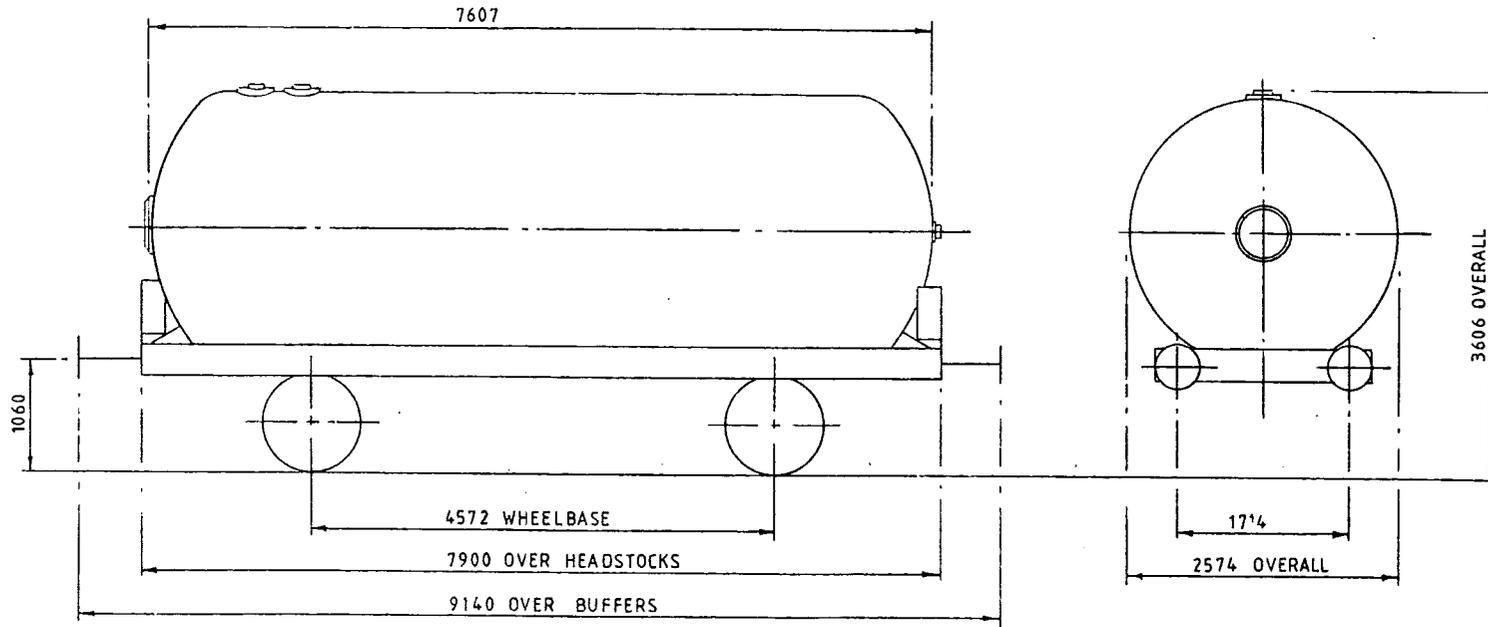

TARE-	23.000 Kg
CAPACITY, WEIGHT-	23.000 Kg
CAPACITY, VOLUME-	35.558 litres
MIN. CURVE-	31 m
GEN. ARRGT. DRG. NO.-	

BRAKE-	AIR BLOCK & HAND LEVER
SUSPENSION-	DOUBLE LINK & PARABOLIC SPRING
COUPLINGS-	INTERNATIONAL SCREW
BUFFERS-	HYDRAULIC 406 DIA HEADS
WHEELS-	952 DIA
JOURNALS-	140 DIA ROLLER BEARINGS

ISSUE 1

46 tonne GLW TANK WAGON L.P.G.

LOT NUMBER	

TOPS INFORMATION						
AARKND	OPERATING	OPERATING SPEED		BRAKE FORCE DATA		EXCESS LENGTH
CARKND	PANEL No.	60 mile/h UP TO	46 tonne GLW	9 t FORCE UP TO	30.5 tonne GLW	RA (GLW)
T T A		mile/h ABOVE		24 t FORCE ABOVE		5
						9
						DESIGN SHEET W1040

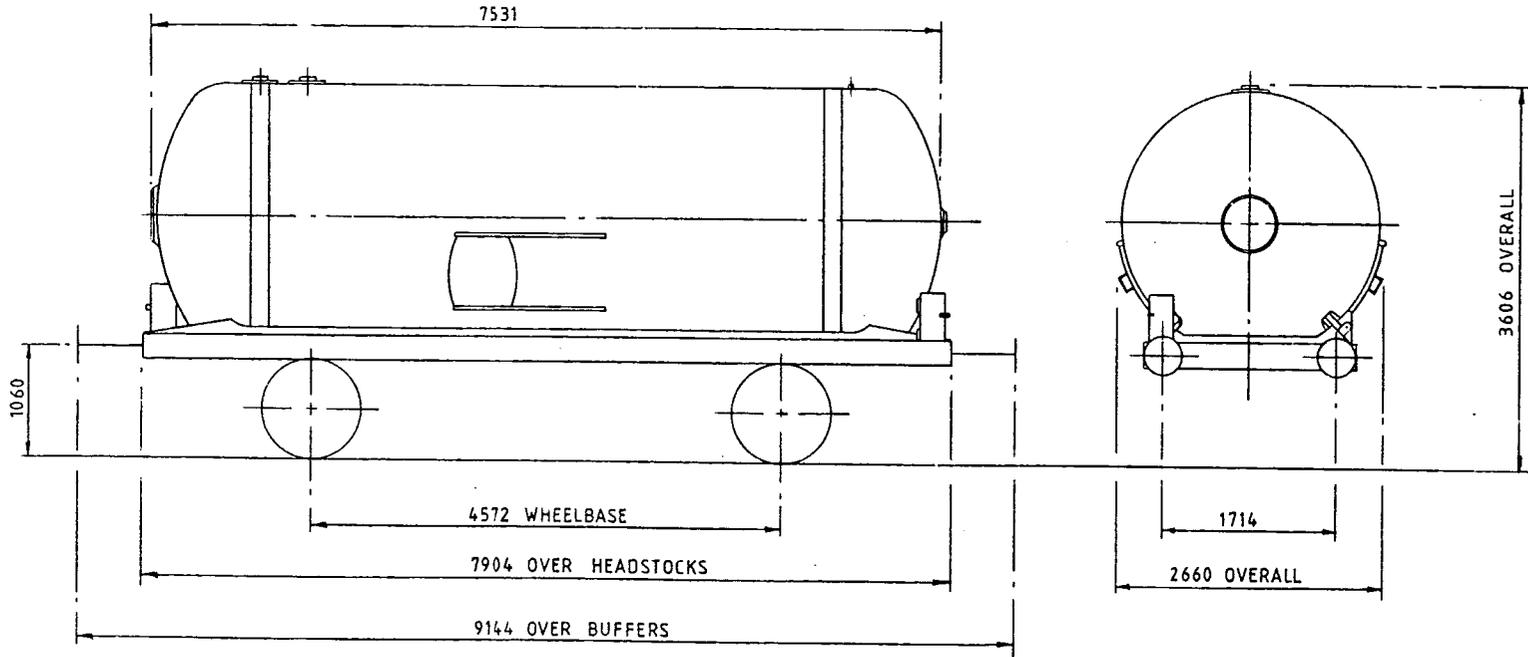

TARE-	22.500 Kg
CAPACITY, WEIGHT-	23.500 Kg
CAPACITY, VOLUME-	35.495 litres
MIN. CURVE-	31 m
GEN. ARRGT. DRG. NO.-	

BRAKE-	AIR BLOCK & HAND LEVER
SUSPENSION-	DOUBLE LINK & PARABOLIC SPRING
COUPLINGS-	INTERNATIONAL SCREW
BUFFERS-	HYDRAULIC 406 DIA HEADS
WHEELS-	952 DIA
JOURNALS-	140 DIA ROLLER BEARINGS

ISSUE 1

46 tonne G.L.W. TANK WAGON - LIQUEFIED PETROLEUM GAS

TTO17K

LOT NUMBER	

TOPS INFORMATION						
AARKND	OPERATING	OPERATING SPEED		BRAKE FORCE DATA		EXCESS LENGTH
CARKND	PANEL No.	60 mile/h UP TO	46 tonne GLW	10t FORCE UP TO	30.5 tonne G.L.W.	5
T T A		mile/h ABOVE		26.7t FORCE ABOVE		7
						DESIGN SHEET W 1625

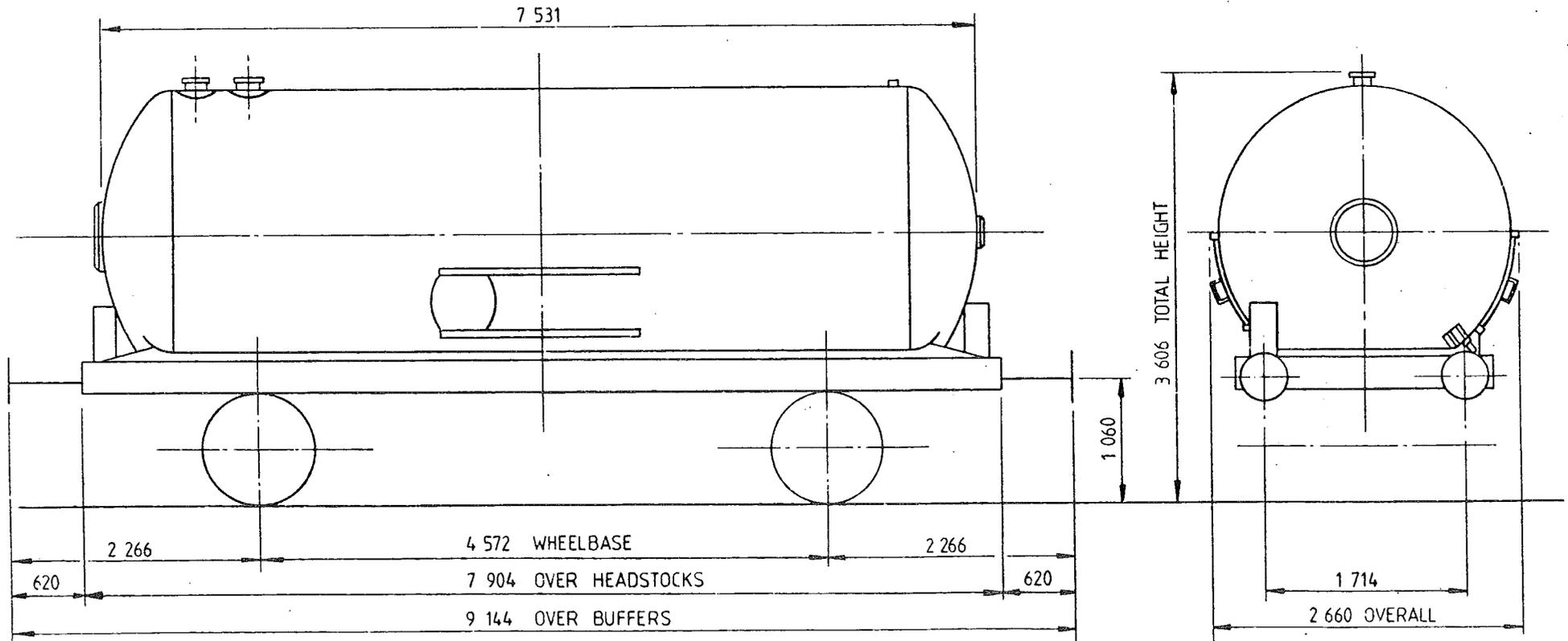

TARE-	22 250 kg
CAPACITY, WEIGHT-	23 750 kg
CAPACITY, VOLUME-	35 495 litres
MIN. CURVE-	31m
GEN. ARRGT. DRG. NO.-	

BRAKE-	AIR, BLOCK & HAND LEVER
SUSPENSION-	UIC DOUBLE LINK & PARABOLIC TAPERLEAF SPRINGS
COUPLINGS-	INTERNATIONAL SCREW
BUFFERS-	HYDRAULIC 406 DIA HEADS
WHEELS-	952 DIA
JOURNALS-	140 DIA ROLLER BEARINGS

ISSUE 1.

46 tonne G.L.W. TANK WAGON - LIQUEFIED PETROLEUM GAS

TTO17L

LOT NUMBER	

TOPS INFORMATION											
AARKND		OPERATING		OPERATING SPEED			BRAKE FORCE DATA		EXCESS LENGTH	RA (GLW)	DESIGN SHEET
CARKND		PANEL No.		60 mile/h UP TO mile/h ABOVE			46 tonne GLW				
T	T	A	A					10+ FORCE UP TO 26.7+ FORCE ABOVE	30.5 tonne G.L.W.		

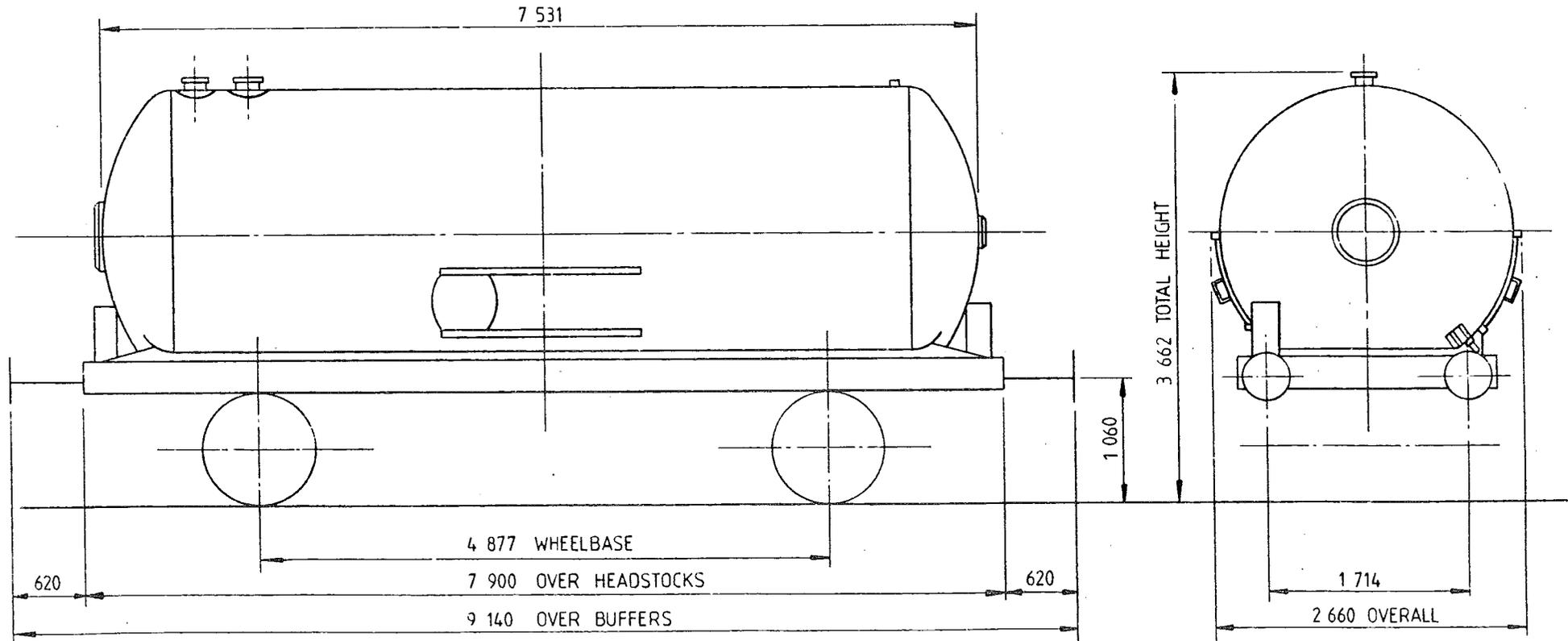

TARE-	23 100kg
CAPACITY, WEIGHT-	22 900kg
CAPACITY, VOLUME-	35 495 litres
MIN. CURVE-	31m
GEN. ARRGT. DRG. NO.-	

BRAKE-	AIR, BLOCK & HAND LEVER
SUSPENSION-	UIC DOUBLE LINK & PARABOLIC TAPERLEAF SPRINGS
COUPLINGS-	INTERNATIONAL SCREW
BUFFERS-	HYDRAULIC 406 DIA HEADS
WHEELS-	952 DIA.
JOURNALS-	140 DIA ROLLER BEARINGS

ISSUE 1.

46 tonne G.L.W. TANK WAGON - LIQUEFIED PETROLEUM GAS

TTO17M

LOT NUMBER	

TOPS INFORMATION						
AARKND	OPERATING	OPERATING SPEED		BRAKE FORCE DATA		EXCESS LENGTH
CARKND	PANEL No.	60 mile/h UP TO	46 tonne GLW	10t FORCE UP TO	30.5 tonne G.L.W.	RA (GLW)
T T A		mile/h ABOVE		26t FORCE ABOVE		5
						7
						W 1627

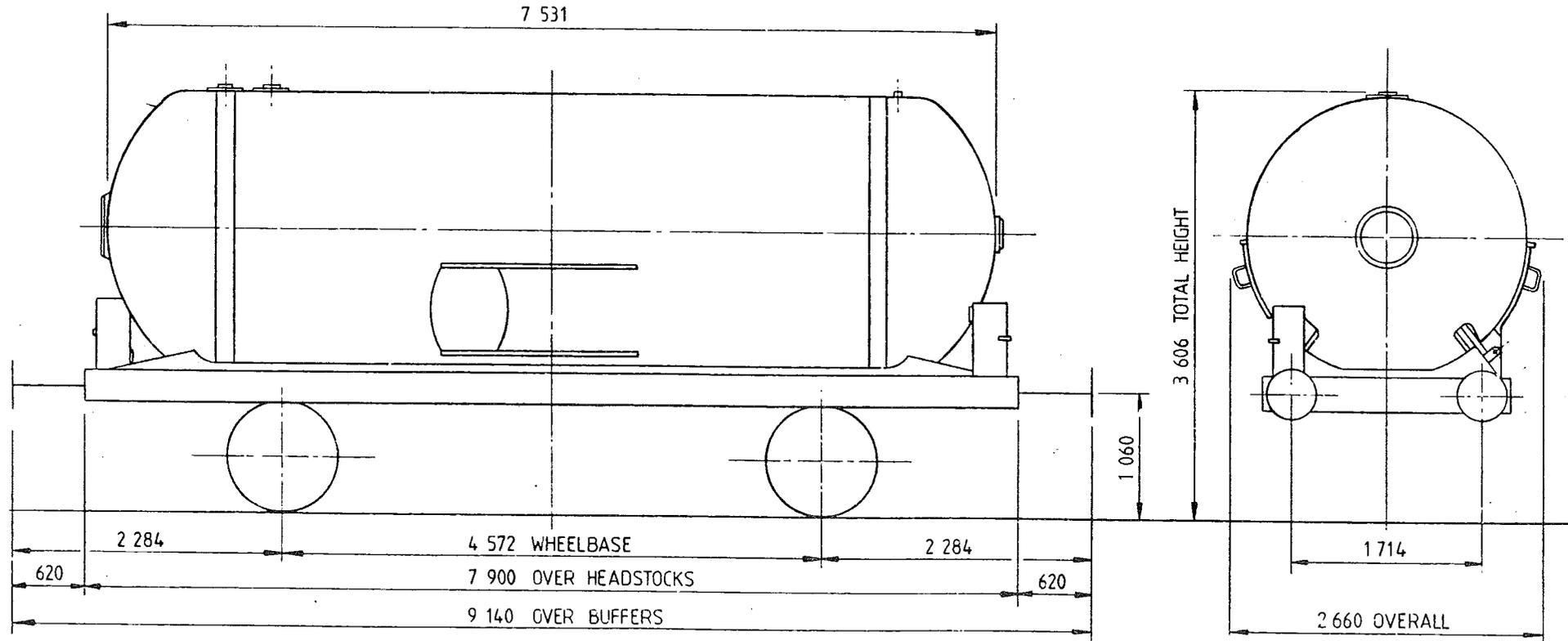

TARE-	21 750 kg
CAPACITY, WEIGHT-	24 250 kg
CAPACITY, VOLUME-	35.495 litres
MIN. CURVE-	31m
GEN. ARRGT. DRG. NO.-	

BRAKE-	AIR, BLOCK & HAND LEVER
SUSPENSION-	U.I.C. DOUBLE LINK WITH PARABOLIC SPRING
COUPLINGS-	INTERNATIONAL SCREW
BUFFERS-	HYDRAULIC 406 DIA HEADS
WHEELS-	952 DIA
JOURNALS-	140 DIA. ROLLER BEARINGS

ISSUE 1.

LOT NUMBER	

TOPS INFORMATION								
AARKND	OPERATING	OPERATING SPEED		BRAKE FORCE DATA		EXCESS LENGTH	RA (GLW)	DESIGN SHEET
CARKND	PANEL No.	60 mile/h UP TO	46 tonne GLW	10t FORCE UP TO	30.5 tonne G.L.W.	5	7	W1628
T T A		mile/h ABOVE		26.7t FORCE ABOVE				

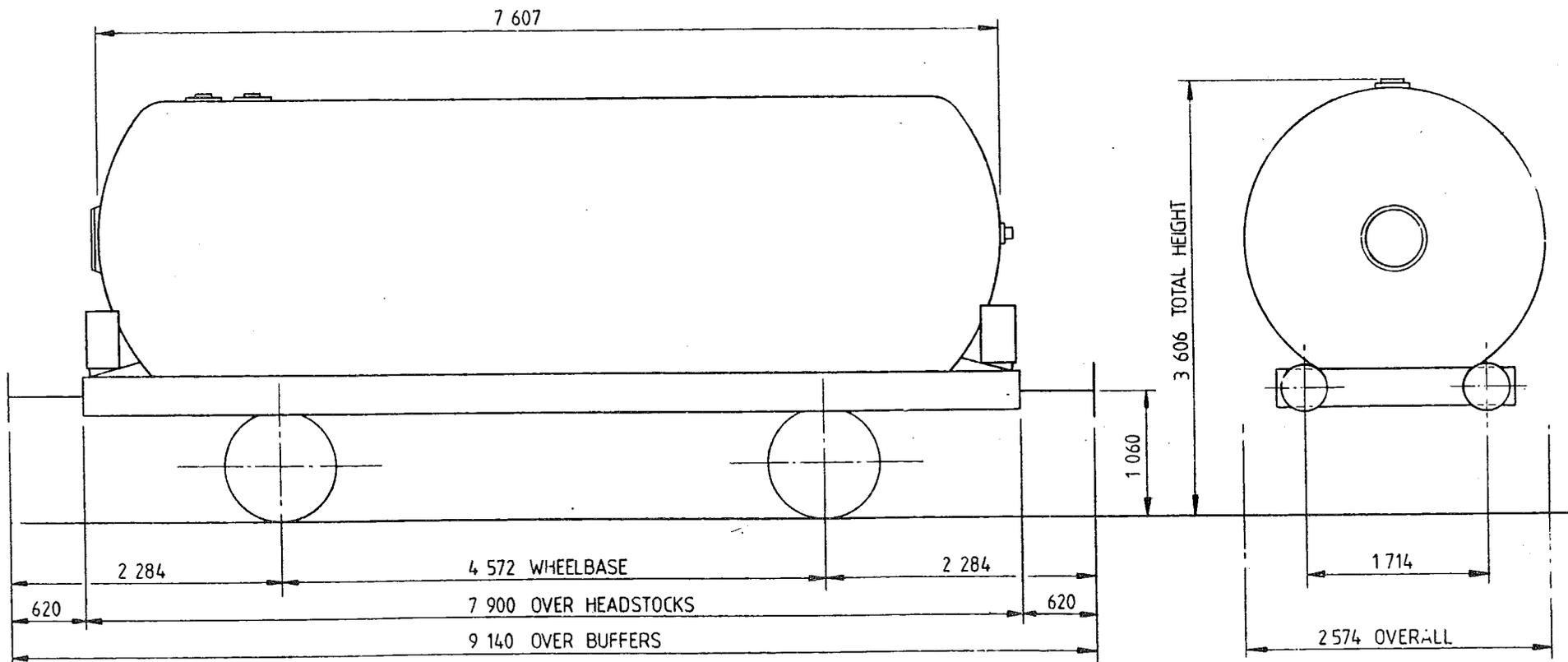

TARE-	23 100kg
CAPACITY, WEIGHT-	22 900kg
CAPACITY, VOLUME-	35 558 litres
MIN. CURVE-	31m
GEN. ARRGT. DRG. NO.-	

BRAKE-	AIR, BLOCK & HAND LEVER
SUSPENSION-	UIC DOUBLE LINK & PARABOLIC TAPERLEAF SPRING
COUPLINGS-	INTERNATIONAL SCREW
BUFFERS-	HYDRAULIC 406 DIA. HEADS
WHEELS-	952 DIA.
JOURNALS-	140 DIA. ROLLER BEARINGS

ISSUE 1.

LOT NUMBER	

TOPS INFORMATION										
AARKND		OPERATING		OPERATING SPEED		BRAKE FORCE DATA		EXCESS LENGTH	RA (GLW)	DESIGN SHEET
CARKND		PANEL No.		60 mile/h UP TO mile/h ABOVE		46 tonne GLW				
T	T	A	A					5	7	W1629

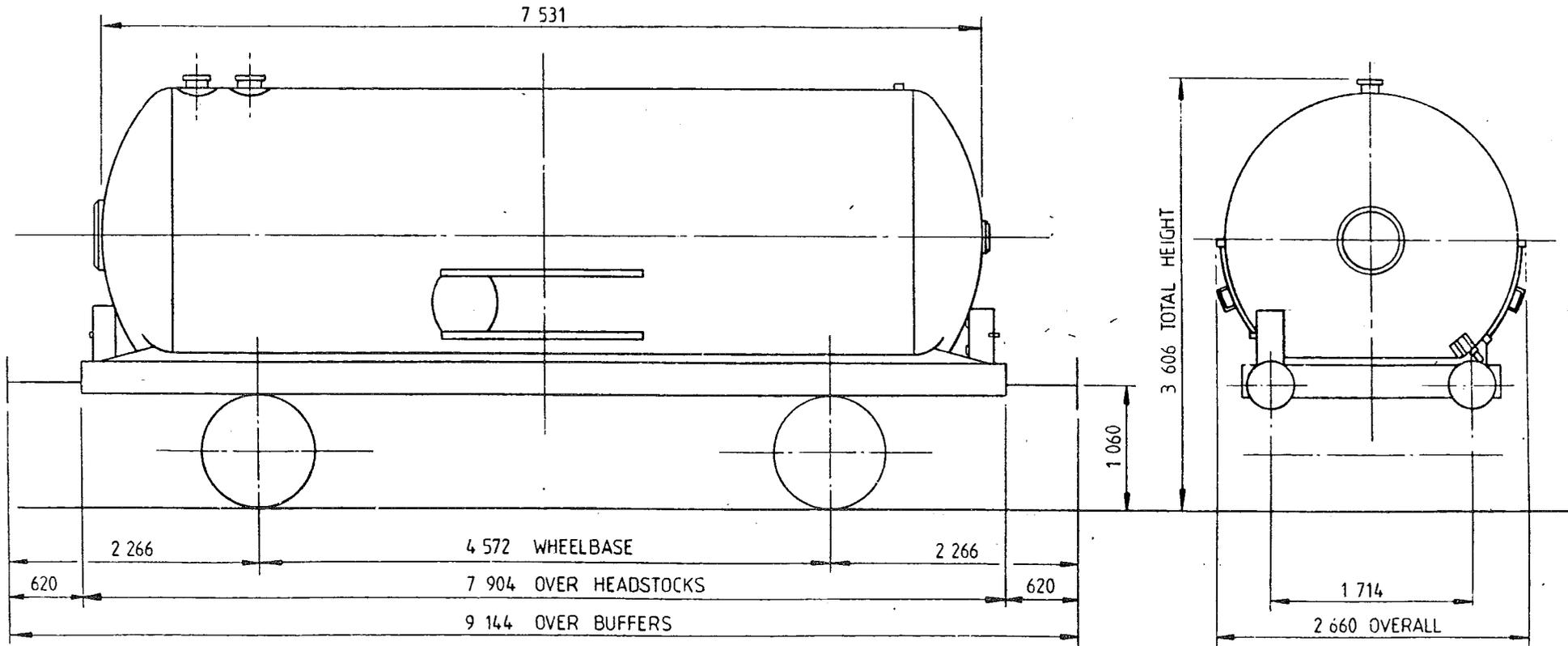

TARE-	21 750 kg
CAPACITY, WEIGHT-	24 250 kg
CAPACITY, VOLUME-	35 495 litres
MIN. CURVE-	31m
GEN. ARRGT. DRG. NO.-	

BRAKE-	AIR, BLOCK & HAND LEVER
SUSPENSION-	UIC DOUBLE LINK & PARABOLIC TAPERLEAF SPRINGS
COUPLINGS-	INTERNATIONAL SCREW
BUFFERS-	HYDRAULIC 406 DIA HEADS
WHEELS-	952 DIA
JOURNALS-	140 DIA ROLLER BEARINGS

ISSUE 1.

46 tonnes G.L.W. TANK WAGON - LIQUEFIED PETROLEUM GAS

TTO18A

EXCESS LENGTH	7	H	M	L	E
tonnes	46	46	21	21	
VB	0	0	0	0	
AB	21	21	12	12	
RA	8	7	1	1	
MAX. SPEED	60	60	60	60	

TOPS CODE										
CARKND	AARKND			OPENING PANEL						
T	T	B	T	T	B	A	I	4	4	0

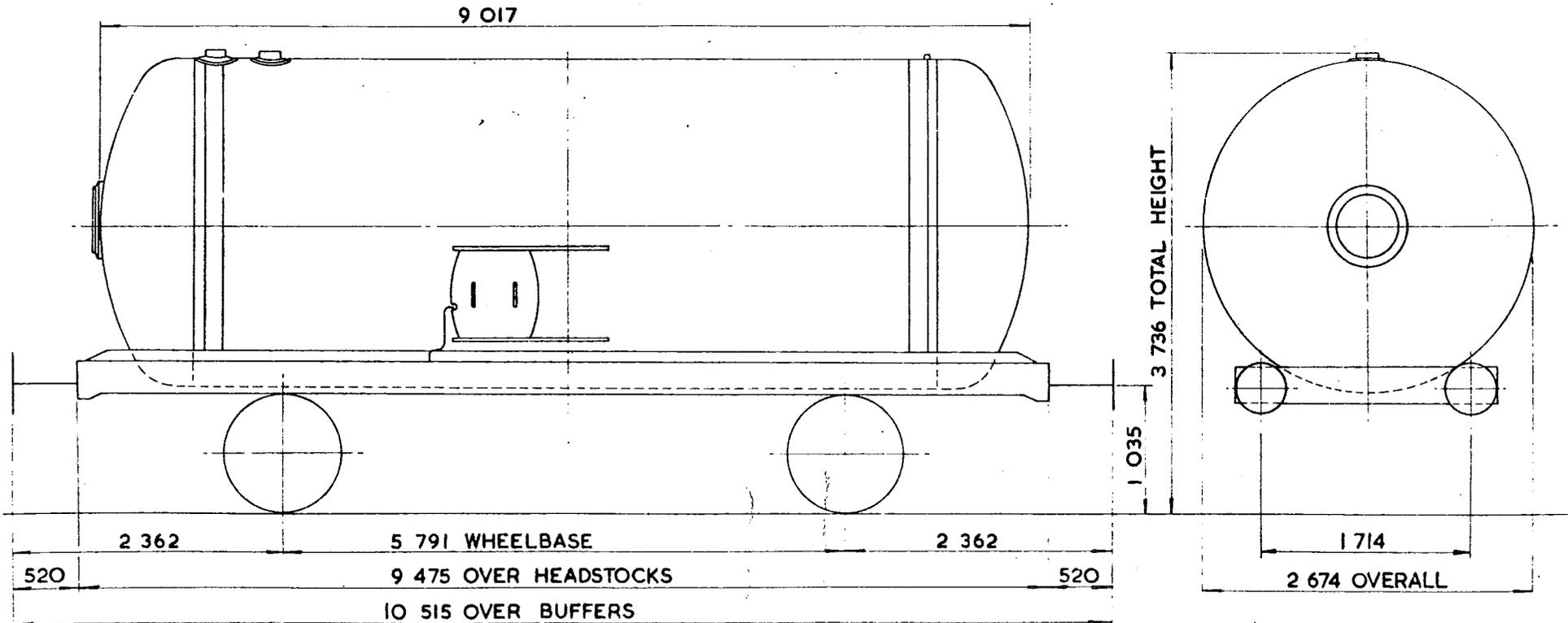

TARE - 20 ³⁰⁰ kg
CARRYING CAPACITY - 20 ⁵⁰⁰ kg PROPANE 25 ⁸⁰⁰ kg BUTANE
CAPACITY - 47 251 litres
MAX. SPEED - 60 mile/h
WHEELS - 952 DIA.
JOURNALS - 140 DIA. ROLLER BEARINGS

BUFFERS - HYDRAULIC 406 DIA. HEADS
COUPLINGS - INSTANTER
MIN CURVE - 31m
GEN. ARRGT. DRG No -
BR. - AIR BLOCK, VACUUM PIPED & HAND LEVER
SUSPENSION - DOUBLE LINK

BUILDER - R.Y. PICKERING
OWNER - B.R.T. & E. LTD.
REGISTERED BY - C.M. & E.E. (B.R.B.) DERBY
YEAR BUILT - 1967
REGISTRATION Nos. - 57577 TO 57587
OWNERS Nos. - 10227 - 10237

ISSUE 2
EX P.O. DIAGRAM 6/209

46 tonnes G.L.W. TANK WAGON-LIQUEFIED PETROLEUM GAS

TTO18B

EXCESS LENGTH	7	H	M	L	E
tonnes.	46	46	21	21	
VB	0	0	0	0	
AB	27	27	16	16	
RA	8	7	1	1	
MAX. SPEED	60	60	60	60	

TOPS CODE										
CARKND		AARKND			OPERATING PANEL No					
T	T	B	T	T	B	A	1	1	5	2

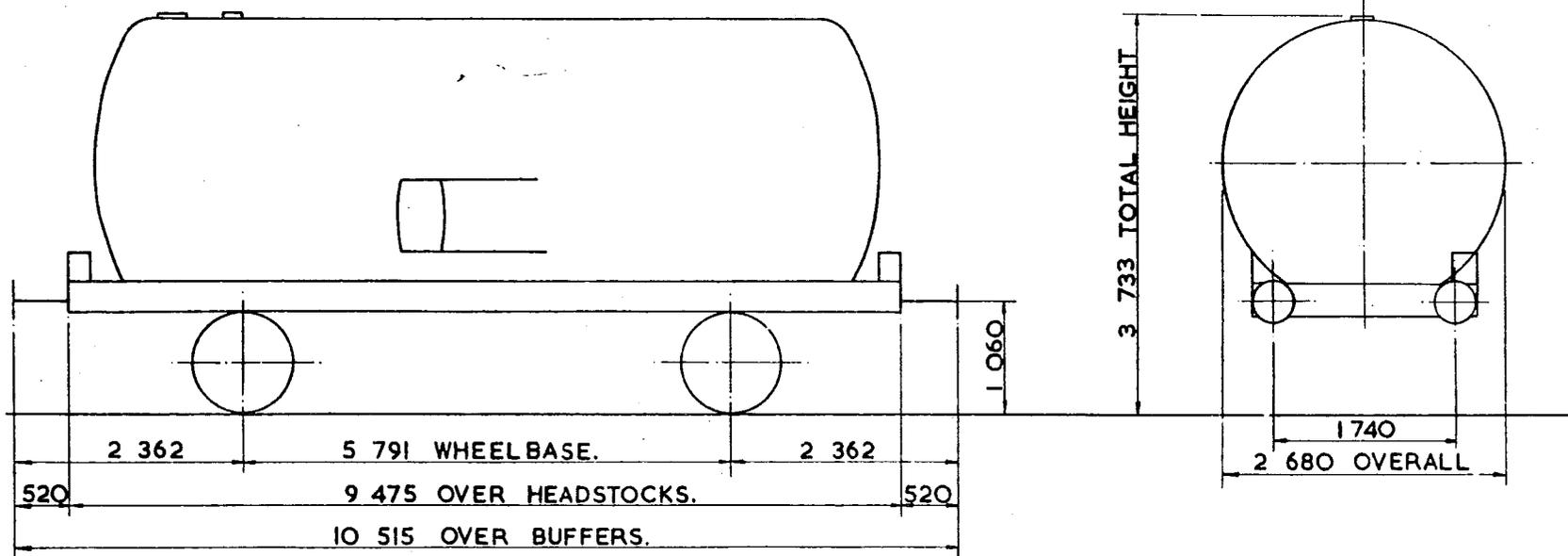

TARE - 2 1350kg.
CARRYING CAPACITY - 24 600kg
CUBIC CAPACITY - 47287 litres
MAX. SPEED - 60 mile/h
WHEELS - 933 DIA.
JOURNALS - 140 DIA. ROLLER BEARINGS.

BUFFERS - HYDRAULIC 406 DIA. HEADS.
COUPLINGS - INSTANTER.
MIN. CURVE - 36m.
GEN. ARRGT. DRG. No. -
BRAKE - AIR BLOCK, VACUUM PIPED & HAND LEVER.
SUSPENSION - PEDESTAL.

BUILDER - CHARLES ROBERTS.
OWNER - BRITISH RAILWAY TRAFFIC & ELECTRIC.
REGISTERED BY - C. M. & E. E. (B.R.B.) DERBY.
YEAR BUILT - 1974 / 75
REGISTRATION Nos. - 57881 TO 57886.
OWNERS Nos. - 57881 TO 57886.

ISSUE 2
EX. P.O. DIAGRAM 6/823 (ALLOCATED)

46tonnes G.L.W. CO₂ TANK WAGON

TTO18E

EXCESS LENGTH 4	H	M	L	E
tonnes	46	46	21	21
VB	0	0	0	0
AB	24	24	16	16
RA	8	8	1	1
MAX SPEED	60	60	60	60

TOPS CODE						
CARKND	AARKND			OPERATING PANEL No		
T	T	B	T	T	B	A
1	3	6	7			

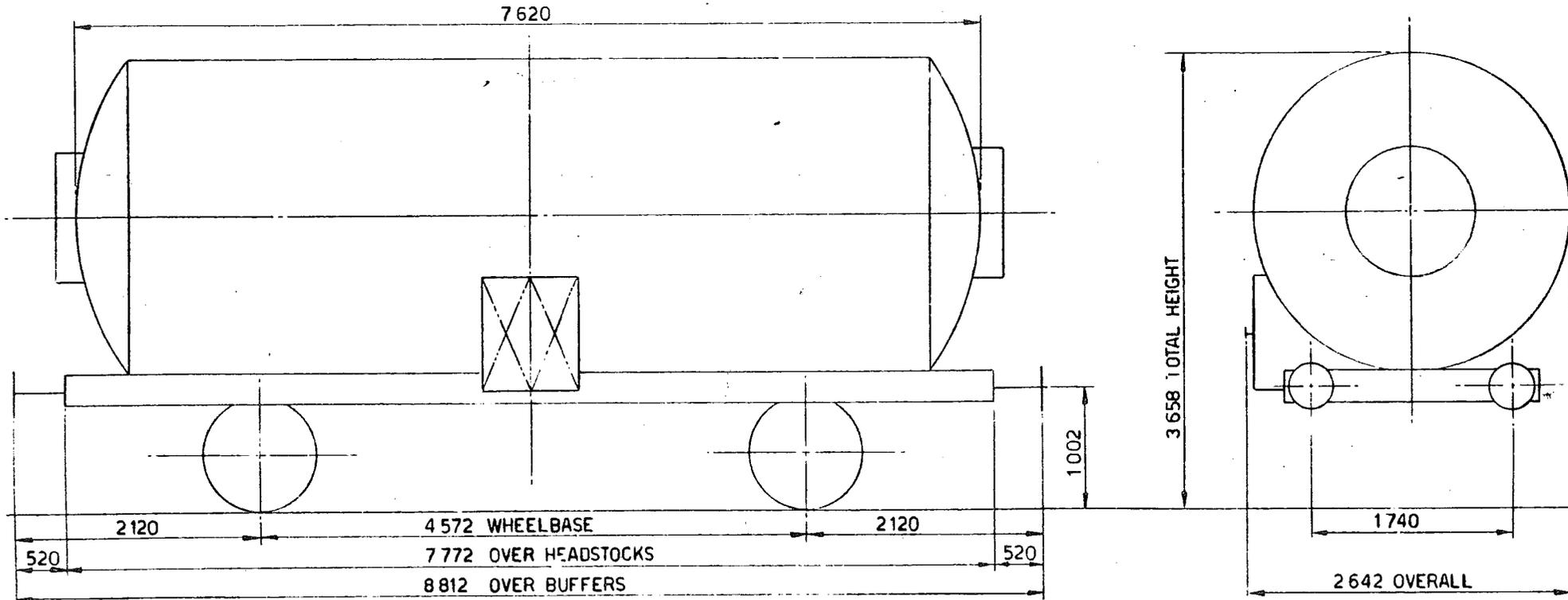

TARE - 18400kg
CARRYING CAPACITY - 27400kg
CAPACITY - 28312 litres.
MAX SPEED - 60mile/h.
WHEELS - 914 DIA.
JOURNALS - 140 DIA. ROLLER BEARINGS.

BUFFERS HYDRAULIC 406 DIA HEADS.
COUPLINGS INSTANTER
MIN CURVE 31m.
GEN ARRGT DRG No
BRAKE AIR, BLOCK, VACUUM PIPED, and HAND LEVER.
SUSPENSION - GLOUCESTER PEDESTAL.

ISSUE 1

EX. PO. DIAGRAM 6/750 (ALLOCATED).

46tonnes G.L.W. CO₂ TANK WAGON

TTO18F

EXCESS LENGTH	3	H	M	L	E
tonnes	46	46	23	23	
VB	0	0	0	0	
AB	21	21	12	12	
RA	8	8	1	1	
MAX. SPEED	60	60	60	60	

TOPS CODE										
CARKND		AARKND			OPERATING PANEL No					
T	T	B	T	T	B	A	1	4	4	1

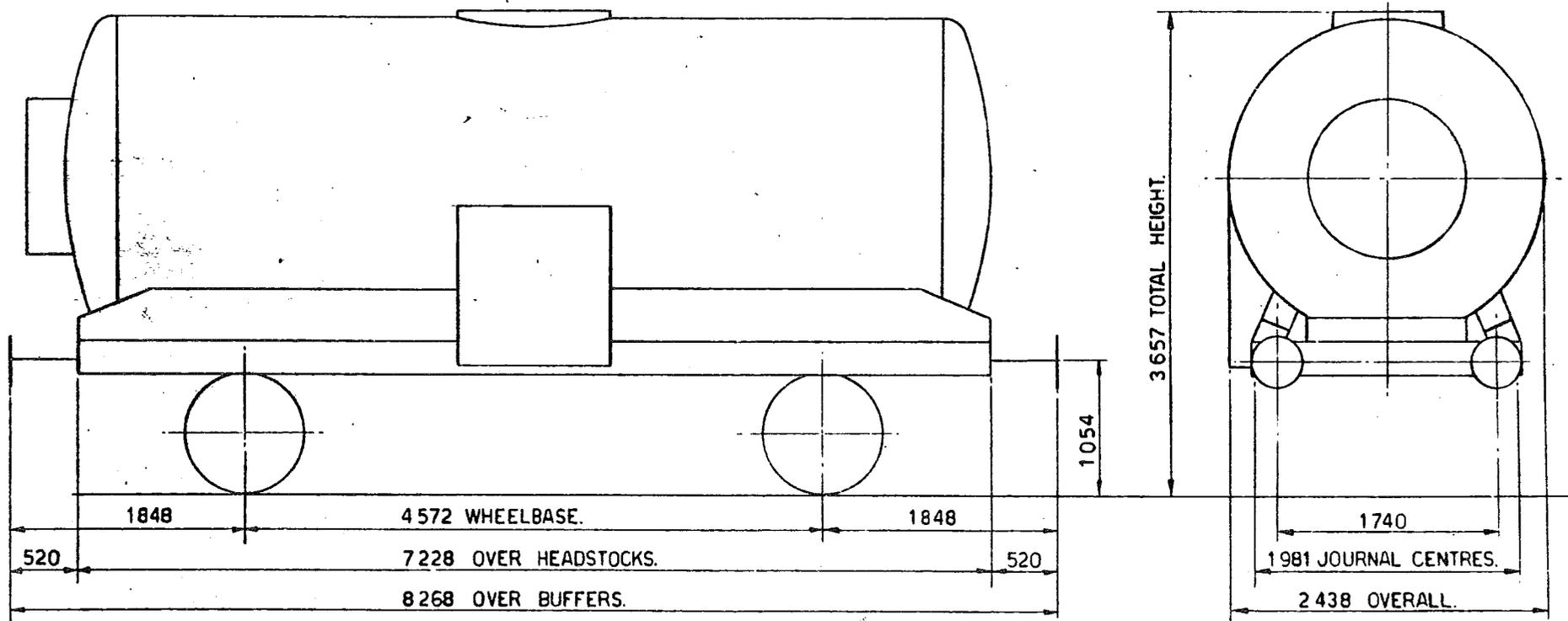

TARE - 21 ⁶⁵⁰ kg
CARRYING CAPACITY - 24,300kg
CAPACITY - 24353 litres
MAX. SPEED - 60 mile/h.
WHEELS - 952DIA.
JOURNALS - 140DIA. ROLLER BEARINGS.

BUFFERS HYDRAULIC, 406DIA. HEADS.
COUPLINGS BR. SCREW.
MIN. CURVE 31m.
GEN ARRGT. DRG No. -
BRAKE - AIR BLOCK, VACUUM PIPED, and HAND LEVER
SUSPENSION - GLOUCESTER PEDESTAL

ISSUE 1

46tonnes G.L.W. CO₂ TANK WAGON

TTO18G

EXCESS LENGTH	3	H	M	L	E
tonnes	46	46	23	23	
VB	0	0	0	0	
AB	23	23	11	11	
RA	8	8	1	1	
MAX. SPEED	60	60	60	60	

TOPS CODE										
CARKND		AARKND			OPERATING PANEL No					
T	T	B	T	T	B	A	1	4	4	2

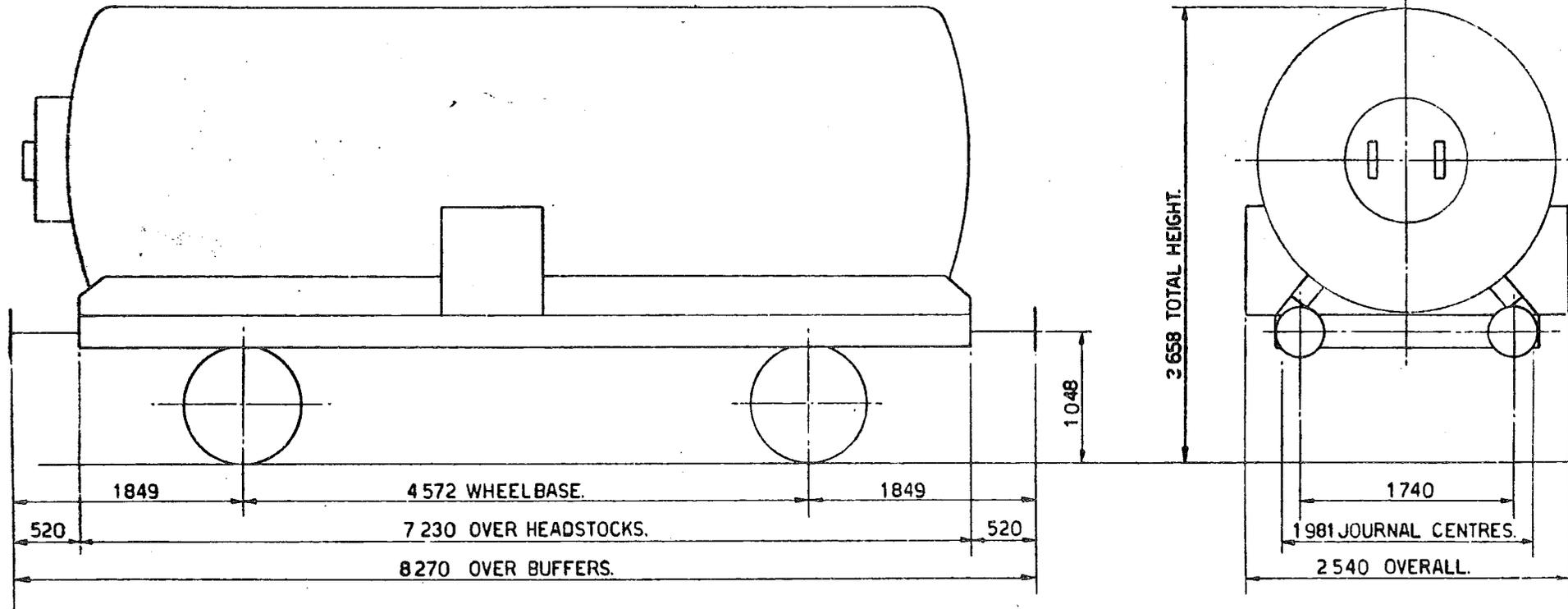

TARE - 20 ⁸⁰⁰ kg.
CARRYING CAPACITY - 25 ²⁰⁰ kg.
CAPACITY - 24333 litres.
MAX. SPEED - 60 mile/h.
WHEELS - 952 DIA.
JOURNALS - 140 DIA. ROLLER BEARINGS

BUFFERS HYDRAULIC 406 DIA. HEADS.
COUPLINGS INSTANTER.
MIN. CURVE - 31m.
GEN. ARRGT. DRG. No. -
BRAKE - AIR, BLOCK, VACUUM PIPED, and HAND LEVER.
SUSPENSION - GLOUCESTER PEDESTAL.

ISSUE 1

EX. P.O. DIAGRAM 6/749 (ALLOCATED)

46 tonne GLW CO₂ TANK WAGON

LOT NUMBER	

TOPS INFORMATION						
AARKND	OPERATING	OPERATING SPEED		BRAKE FORCE DATA		EXCESS
CARKND	PANEL No.	60 mile/h UP TO	46 tonne GLW	12t FORCE UP TO	24.5 tonne GLW	LENGTH
T T A		mile/h ABOVE		2t FORCE ABOVE		3
						RA (GLW)
						8
						DESIGN SHEET
						W1536

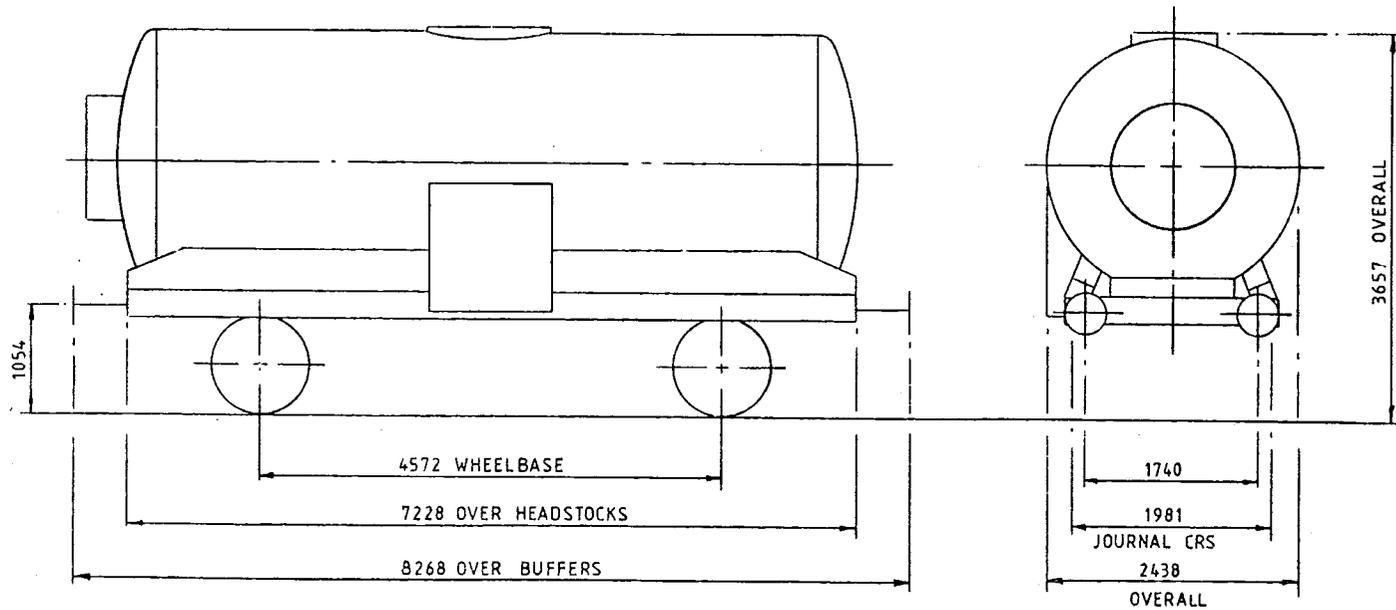

TARE-	21.650 Kg
CAPACITY, WEIGHT-	24.300 Kg
CAPACITY, VOLUME-	24.333 litres
MIN. CURVE-	31m
GEN. ARRGT. DRG. NO.-	

BRAKE-	AIR BLOCK & HAND LEVER
SUSPENSION-	GLOUCESTER PEDESTAL
COUPLINGS-	BR. SCREW
BUFFERS-	HYDRAULIC 406 DIA HEADS
WHEELS-	952 DIA
JOURNALS-	140 DIA ROLLER BEARINGS

ISSUE 1

46 tonne GLW CO₂ TANK WAGON

LOT NUMBER	

TOPS INFORMATION							
AARKND	OPERATING	OPERATING SPEED		BRAKE FORCE DATA	EXCESS	RA	DESIGN
CARKND	PANEL No.	60 mile/h UP TO		16 t FORCE UP TO	LENGTH	(GLW)	SHEET
T T A		mile/h ABOVE		24 t FORCE ABOVE	4	8	WI543
		46 tonne GLW		31 tonne GLW			

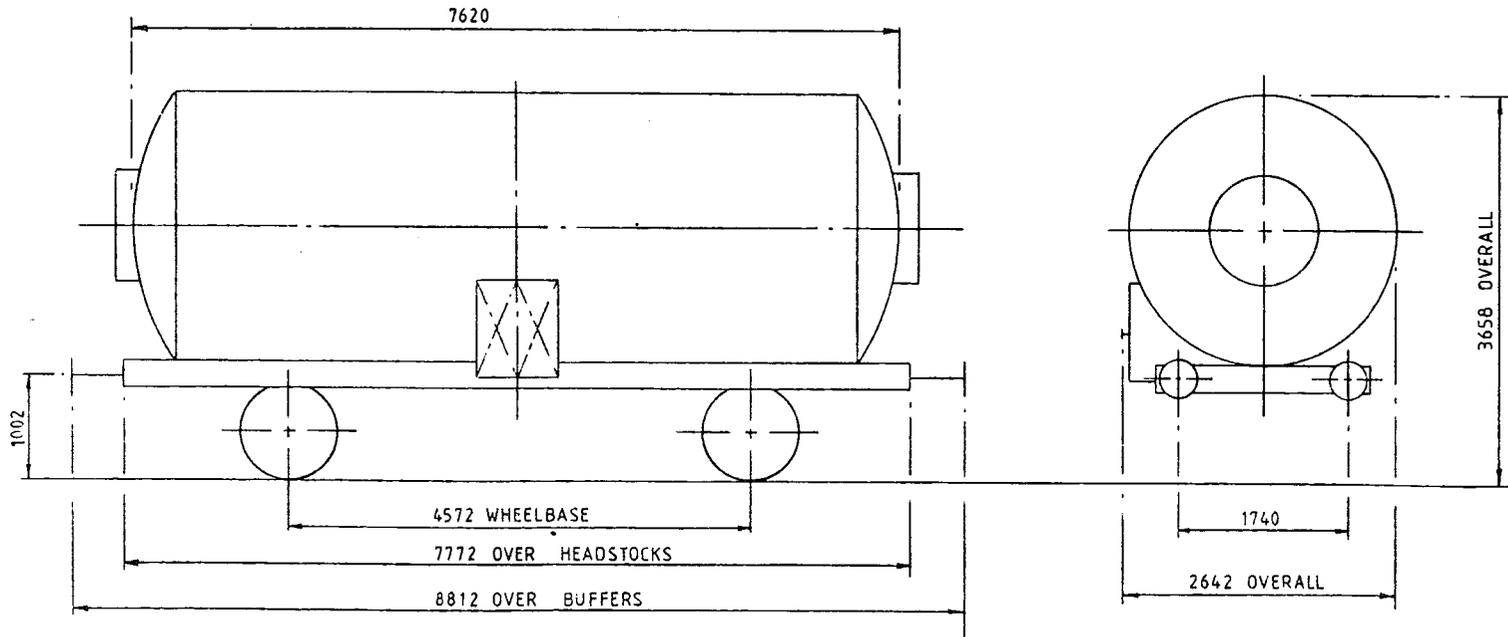

TARE-	18,600 Kg
CAPACITY, WEIGHT-	27,400 Kg
CAPACITY, VOLUME-	28,512 litres
MIN. CURVE-	31m
GEN. ARRGT. DRG. NO.-	

BRAKE-	AIR BLOCK & HAND LEVER
SUSPENSION-	GLOUCESTER PEDESTAL
COUPLINGS-	INSTANTER
BUFFERS-	HYDRAULIC 406 DIA HEADS
WHEELS-	914 DIA
JOURNALS-	140 DIA ROLLER BEARINGS

ISSUE 1

46 tonnes GLW CO₂ TANK WAGON

TTO18K

LOT NUMBER	

TOPS INFORMATION						
AARKND	OPERATING	OPERATING SPEED		BRAKE FORCE DATA		EXCESS LENGTH
CARKND	PANEL No.	60 mile/h UP TO	46 tonne GLW	11† FORCE UP TO	31† GLW	RA (GLW)
T T A A		mile/h ABOVE		23† FORCE ABOVE		3
						9
						W1721

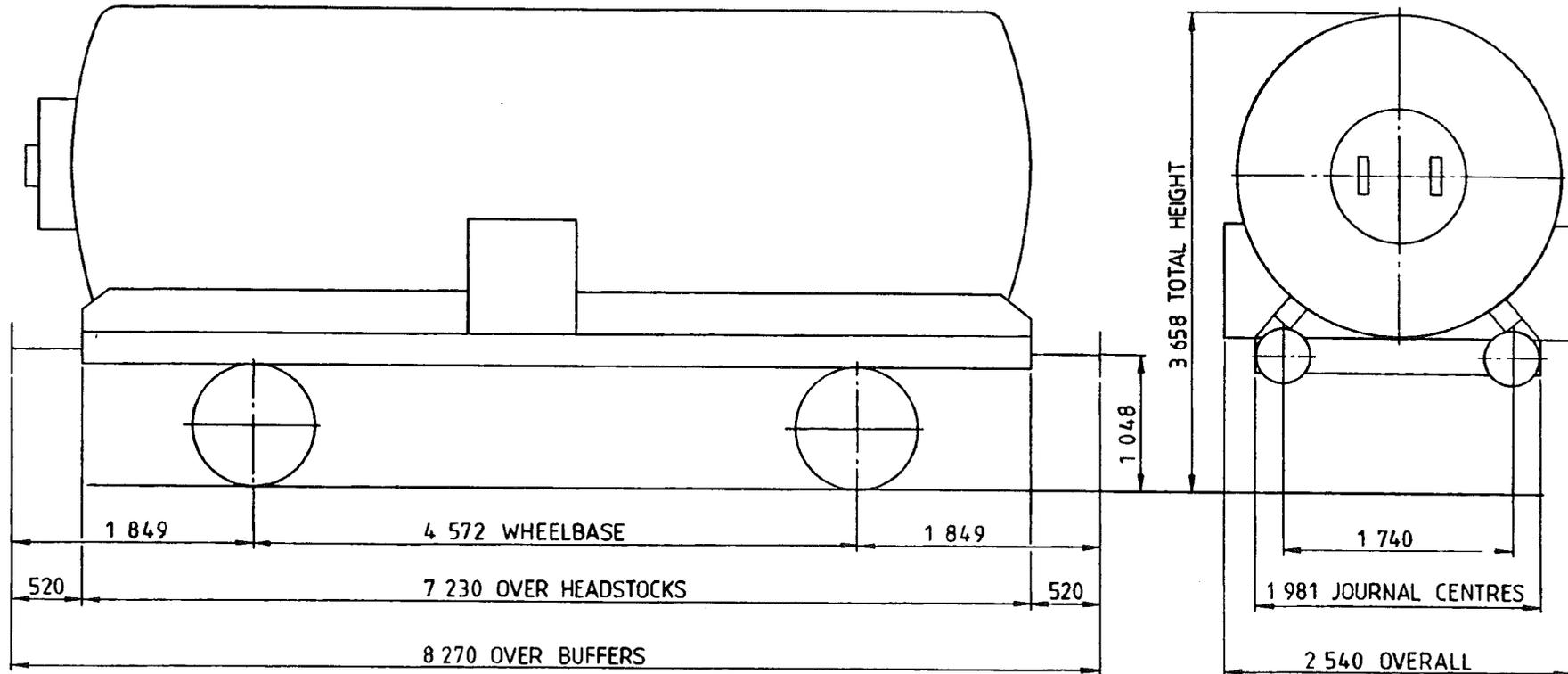

TARE-	20 800kg
CAPACITY, WEIGHT-	25 200kg
CAPACITY, VOLUME-	24 353 LITRES
MIN. CURVE-	31m
GEN. ARRGT. DRG. NO.-	

BRAKE-	AIR BLOCK & HAND LEVER
SUSPENSION-	GLOUCESTER PEDESTAL
COUPLINGS-	INSTANTER
BUFFERS-	HYDRAULIC 406 DIA. HEADS
WHEELS-	952 DIA.
JOURNALS-	140 DIA. ROLLER BEARINGS

ISSUE 1

EX. BR. DIAGRAM

46 tonnes G. L.W. TANK WAGON

TT019A

EXCESS LENGTH	4	H	M	L	E
tonnes	46	46	15	15	
VB	18	18	8	8	
AB					
RA	8	8	1	1	
MAX. SPEED	60	60	45	45	

TOPS CODE									
CARKND		AARKND			OPERATING PANEL				
T	T	F	T	F	A	1	4	4	3

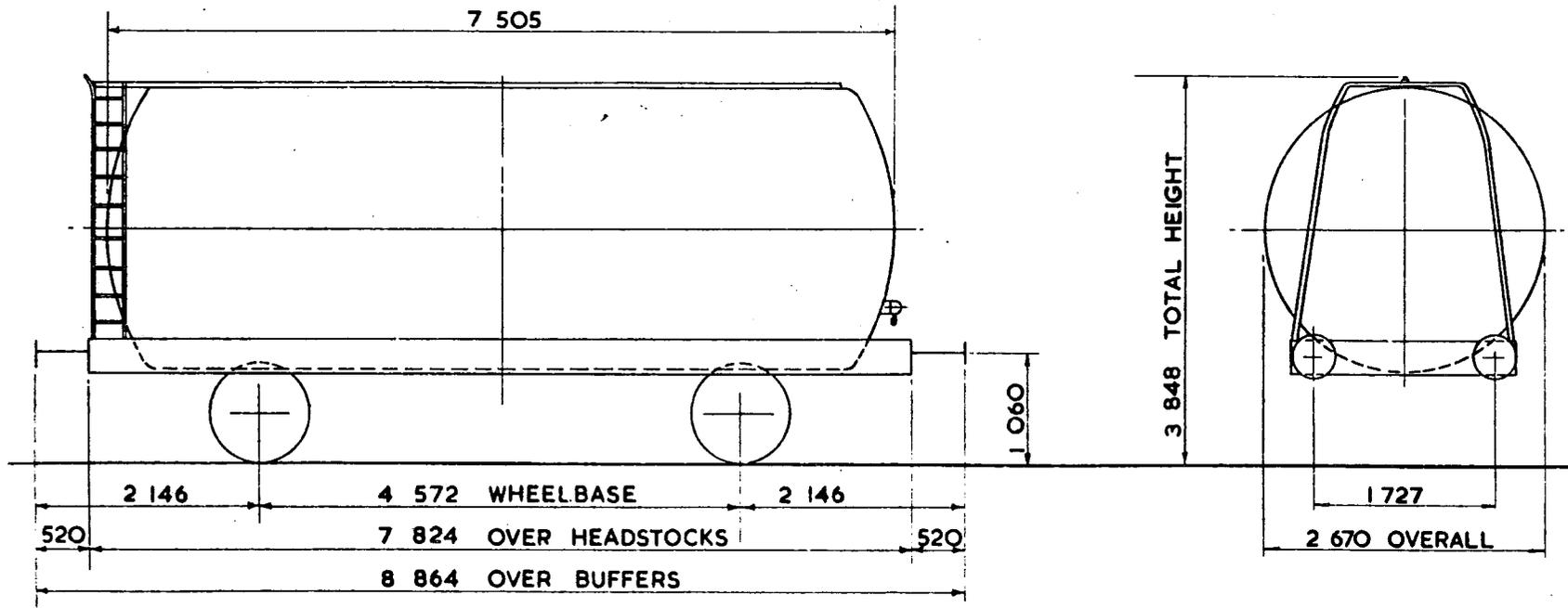

TARE - 14550 kg
CARRYING CAPACITY - 31 400 kg
CAPACITY - 39 414 litres
MAX. SPEED - 60 mile/h.
WHEELS - 952 DIA.
JOURNALS - 140 DIA. ROLLER BEARINGS

BUFFERS - HYDRAULIC 406 DIA. HEADS
COUPLINGS - INSTANTER
MIN. CURVE - 31 m.
GEN. ARRGT. DRG. No. -
BRAKE - VACUUM BLOCK & HAND LEVER.
SUSPENSION - DOUBLE LINK

BUILDER - CHARLES ROBERTS
OWNER - ALGECO (U.K.) LTD.
REGISTERED BY - C.M. & E.E. (B.R.B.) DERBY.
YEAR BUILT - 1964/65
REGISTRATION Nos. - 49006-49056, 49076-49082
OWNERS Nos. - 940-1004, 1027-1037

ISSUE 2
EX. P.O. DIAGRAM 5/148

46 tonnes G.L.W. TANK WAGON

TTO19B

EXCESS LENGTH 4	H	M	L	E
tonnes	46	46	15	15
VB	18	18	8	8
AB	0	0	0	0
RA	8	8	1	1
MAX SPEED	60	60	45	45

TOPS CODE										
CARKND		AARKND		OPERATING PANEL No.						
T	T	W	T	T	W	A	1	4	4	3

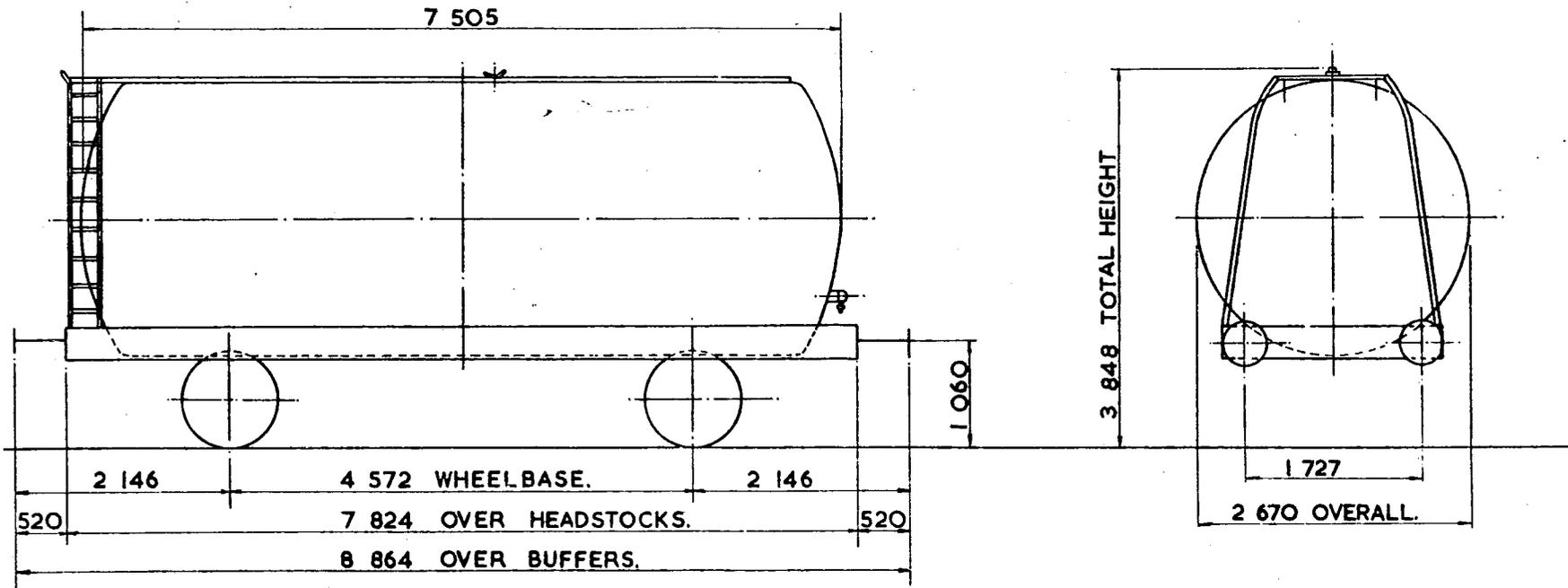

TARE - 14600kg.
CARRYING CAPACITY - 31400kg.
CUBIC CAPACITY - 39414 litres.
MAX. SPEED - 60 mile/h.
WHEELS - 952 DIA.
JOURNALS - 140 DIA ROLLER BEARINGS.

BUFFERS - HYDRAULIC 406 DIA HEADS.
COUPLINGS - INSTANTER.
MIN. CURVE - 31m.
GEN. ARRGT. DRG. No. -
BRAKE - VACUUM BLOCK, AIR PIPED & HAND LEVER.
SUSPENSION - DOUBLE LINK.

BUILDER - CHARLES ROBERTS.
OWNER - ALGECO.
REGISTERED BY - C.M. & E.E. (B.R.B.) DERBY.
YEAR BUILT - 1965.
REGISTRATION Nos. - 49084 TO 49086.
OWNERS Nos. - 1040 TO 1042.

ISSUE 2
EX. P.O. DIAGRAM 5/149

46 tonnes G.L.W. TANK WAGON CLASS A

TT019C

EXCESS LENGTH	4	H	M	L	E
tonnes	46	46	15	15	
VB	0	0	0	0	
AB	26	26	10	10	
RA	8	8	1	1	
MAX. SPEED	60	60	45	45	

TOPS CODE										
CARKND			AARKND			OPERATING PANEL No				
T	T	B	T	T	B	A	1	2	9	2

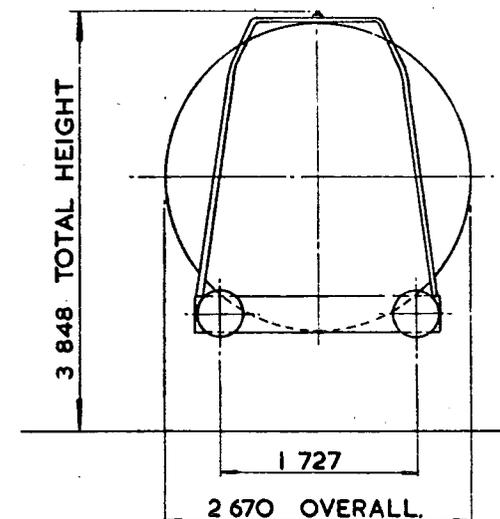
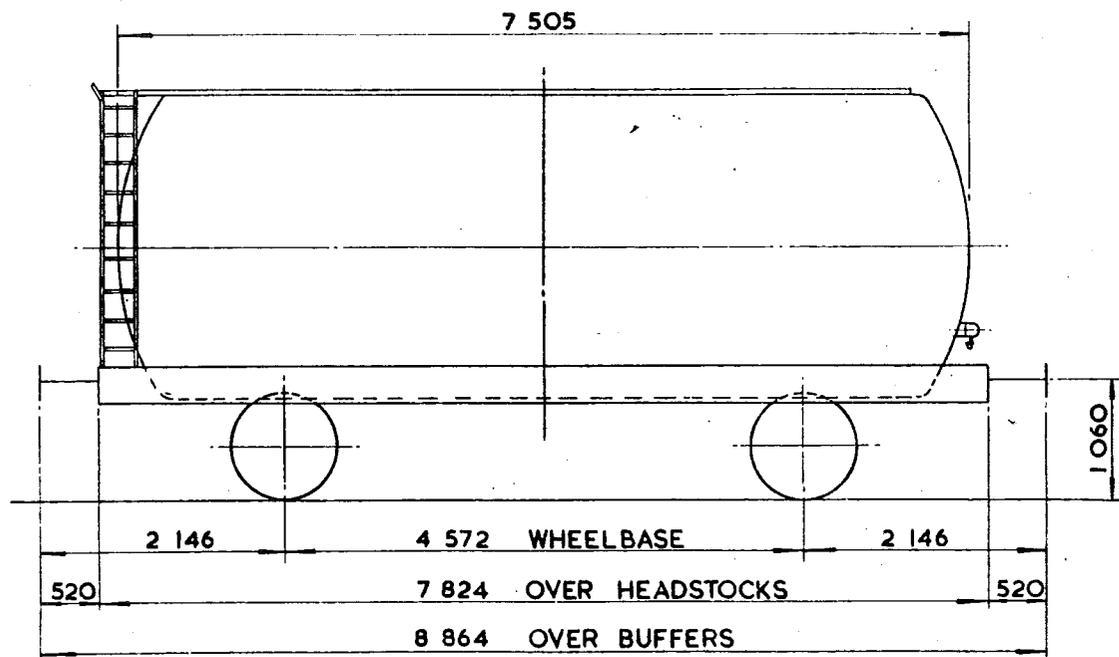

TARE - 14 550 kg
CARRYING CAPACITY - 31 400 kg
CAPACITY - 39 414 litres
MAX. SPEED - 60 mile/h
WHEELS - 952 DIA.
JOURNALS - 140 DIA. ROLLER BEARINGS

BUFFERS - HYDRAULIC 406 DIA. HEADS
COUPLINGS - INSTANTER
MIN CURVE - 31 m
GEN. ARRGT. DRG No. -
BRAKE - AIR BLOCK, VACUUM PIPED & HAND LEVER.
SUSPENSION - DOUBLE LINK

BUILDER - CHARLES ROBERTS
OWNER - ALGECO (U.K.) LTD.
REGISTERED BY - C.M. & E.E. (B.R.B.) DERBY
YEAR BUILT - 1964/65
REGISTRATION Nos - 49057 TO 49062, 49068 - 49075.
OWNERS Nos. - 1005 TO 1010, 1016 TO 1023

ISSUE 2

EX. P.O. DIAGRAM 3/830 (ALLOCATED)

46 tonnes G.L.W. TANK WAGON CLASS A.

TTO19D

EXCESS LENGTH	H	M	L	E
4	46	46	15	15
tonnes	46	46	15	15
VB	18	18	8	8
AB				
RA	8	8	1	1
MAX. SPEED	60	60	45	45

TOPS CODE										
CARKND		AARKND		OPERATING PANEL No						
T	T	F	T	T	F	A	1	4	4	3

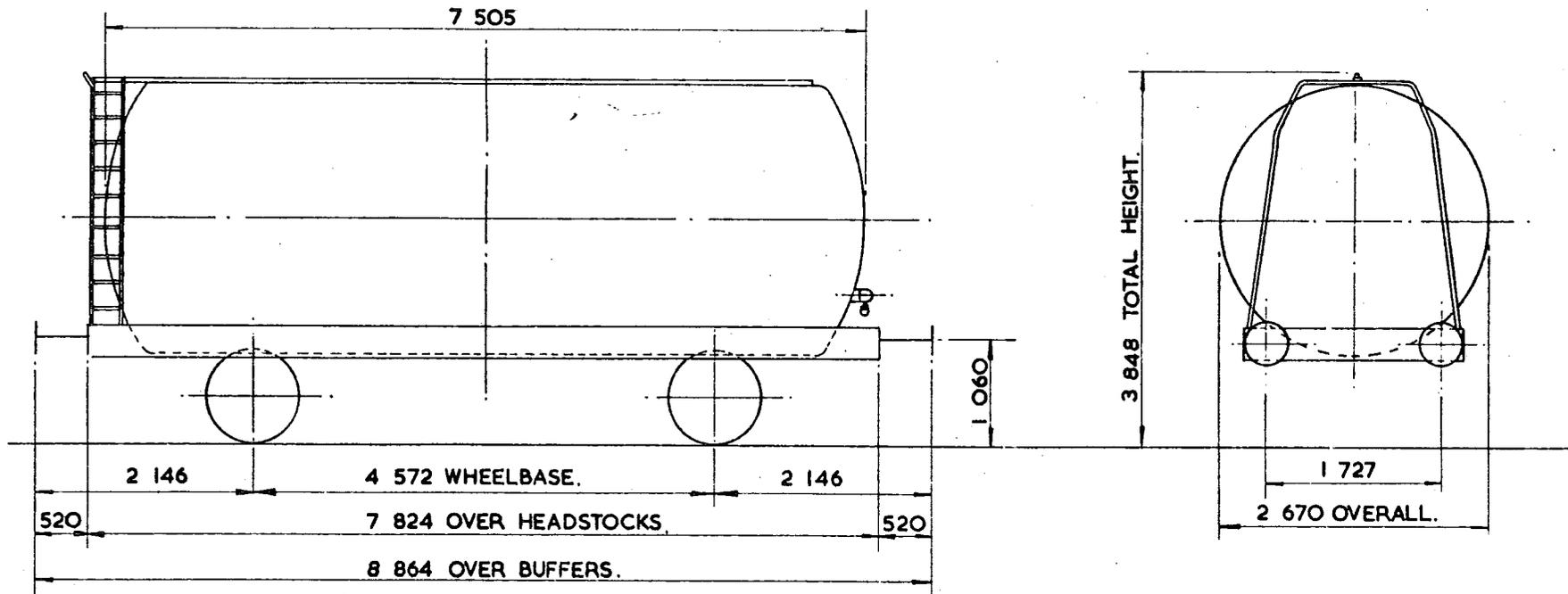

TARE -	14 550kg.
CARRYING CAPACITY	31 400kg
CAPACITY	39.414 m. ³
MAX. SPEED -	60 mlie/h.
WHEELS -	952 DIA.
JOURNALS -	140 DIA. ROLLER BEARINGS

BUFFERS -	HYDRAULIC 406 DIA. HEADS.
COUPLINGS -	INSTANTER.
MIN. CURVE -	31m.
GEN. ARRG. DRG. No. -	
BRAKE -	VACUUM BLOCK & HAND LEVER
SUSPENSION -	DOUBLE LINK.

BUILDER -	CHARLES ROBERTS.
OWNER -	ALGECO (U.K.) LTD.
REGISTERED BY -	C.M. & E.E. (B.R.B.) DERBY.
YEAR BUILT -	1964 / 65.
REGISTRATION Nos. -	49063-49067.
OWNERS Nos. -	

ISSUE 2

EX P.O. DIAGRAM 6/820 (ALLOCATED).

46 tonnes G.L.W. TANK-CLASS A

TT 019E

EXCESS LENGTH	4	H	M	L	E
tonnes	46	46	15	15	
VB	26	26	10	10	
AB					
RA	8	8	1	1	
MAX SPEED	60	60	45	45	

TOPS CODE										
CARKND			AARKND			OPERATING PANEL No				
T	T	B	T	T	B	A	1	2	9	2

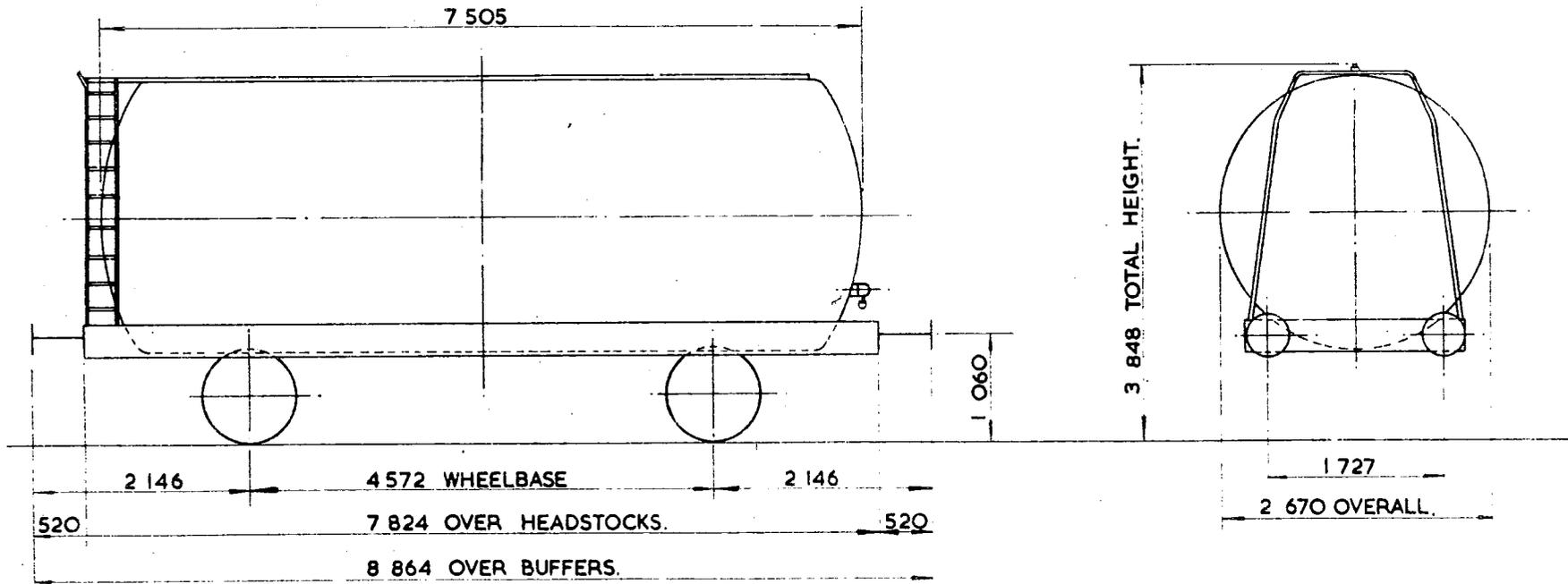

TARE	14 550 kg.
CARRYING CAPACITY	31 400 kg.
CAPACITY	39.414 m ³
MAX SPEED	60 mile/h.
WHEELS	952 DIA.
JOURNALS	140 DIA. ROLLER BEARINGS.

BUFFERS	HYDRAULIC 406 DIA. HEADS.
COUPLINGS	INSTANTER.
MIN CURVE	31m.
GEN ARRGT. DRG No	
BRAKE	VACUUM BLOCK & HAND LEVER.
SUSPENSION	DOUBLE LINK.

BUILDER	CHARLES ROBERTS.
OWNER	ALGECO (U.K.) LTD.
REGISTERED BY	C.M. & E.E. (B.R.B.) DERBY.
YEAR BUILT	1964/65.
REGISTRATION No.	49023
OWNERS Nos	

ISSUE 2
EX. P.O. DIAGRAM 6/835 (ALLOCATED).

46 tonnes G.L.W. TANK WAGON

TTO19F

EXCESS LENGTH	4	H	M	L	E
tonnes	46	46	15	15	
VB	18	18	8	8	
AB					
RA	8	8	1	1	
MAX. SPEED	60	60	45	45	

TOPS CODE										
CARKND					AARKND					OPERATING PANEL No.
T	T	V	T	T	V	A	1	4	4	3

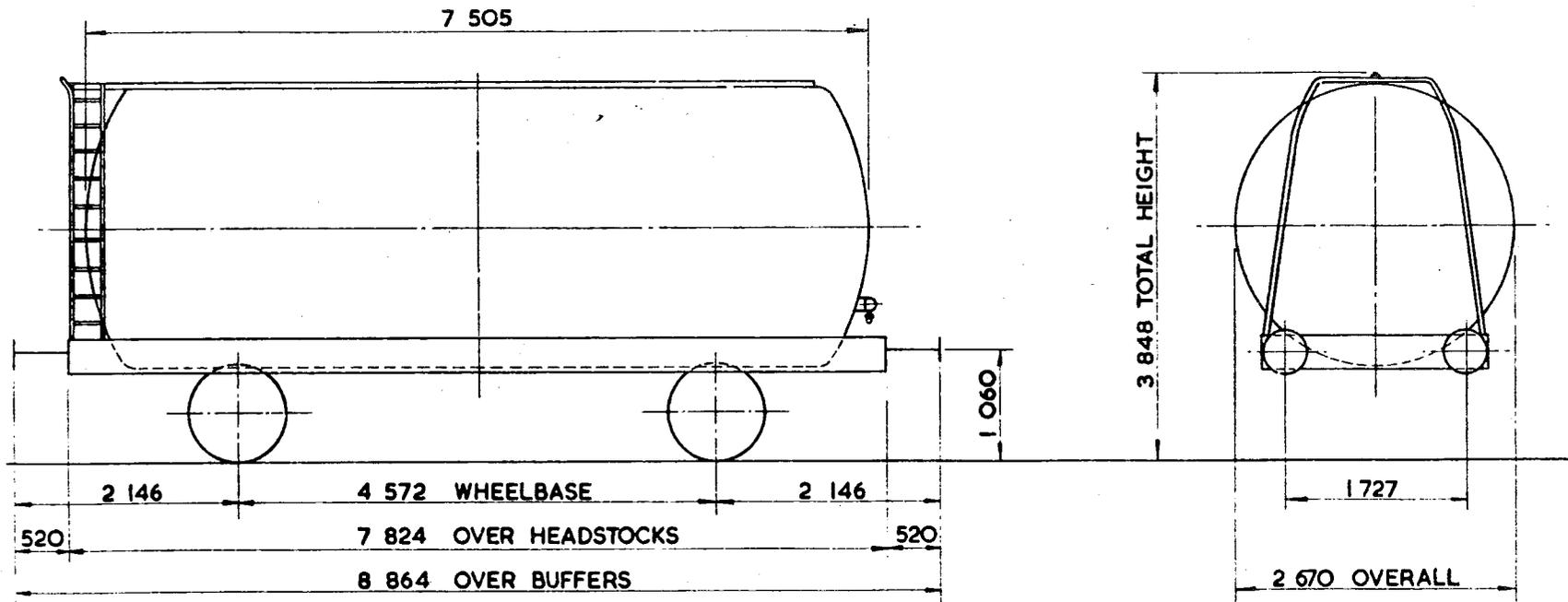

TARE-	14 550 kg
CARRYING CAPACITY-	31 400 kg
CAPACITY-	39 414 litres
MAX. SPEED-	60 mile/h
WHEELS-	952 DIA.
JOURNALS-	140 DIA. ROLLER BEARINGS

BUFFERS-	HYDRAULIC 406 DIA. HEADS
COUPLINGS-	INSTANTER
MIN. CURVE-	31 m
GEN. ARRGT. DRG. No.-	
BRAKE-	VACUUM BLOCK & HAND LEVER
SUSPENSION-	DOUBLE LINK

BUILDER-	CHARLES ROBERTS
OWNER-	ALGECO (U.K.) LTD.
REGISTERED BY-	C.M. & E.E. (B.R.B.) DERBY
YEAR BUILT-	1964/65
REGISTRATION Nos.-	49083
OWNERS Nos.-	

ISSUE 2

EX. P.O. DIAGRAM 6/148

46 tonne GLW TANK WAGON - CLASS A

LOT NUMBER	

TOPS INFORMATION						
AARKND	OPERATING	OPERATING SPEED		BRAKE FORCE DATA		EXCESS LENGTH
CARKND	PANEL No.	60 mile/h UP TO	46 tonne GLW	10t FORCE UP TO	30 tonne GLW	RA (GLW)
T T A A		60 mile/h ABOVE		26t FORCE ABOVE		4
						9
						W1520

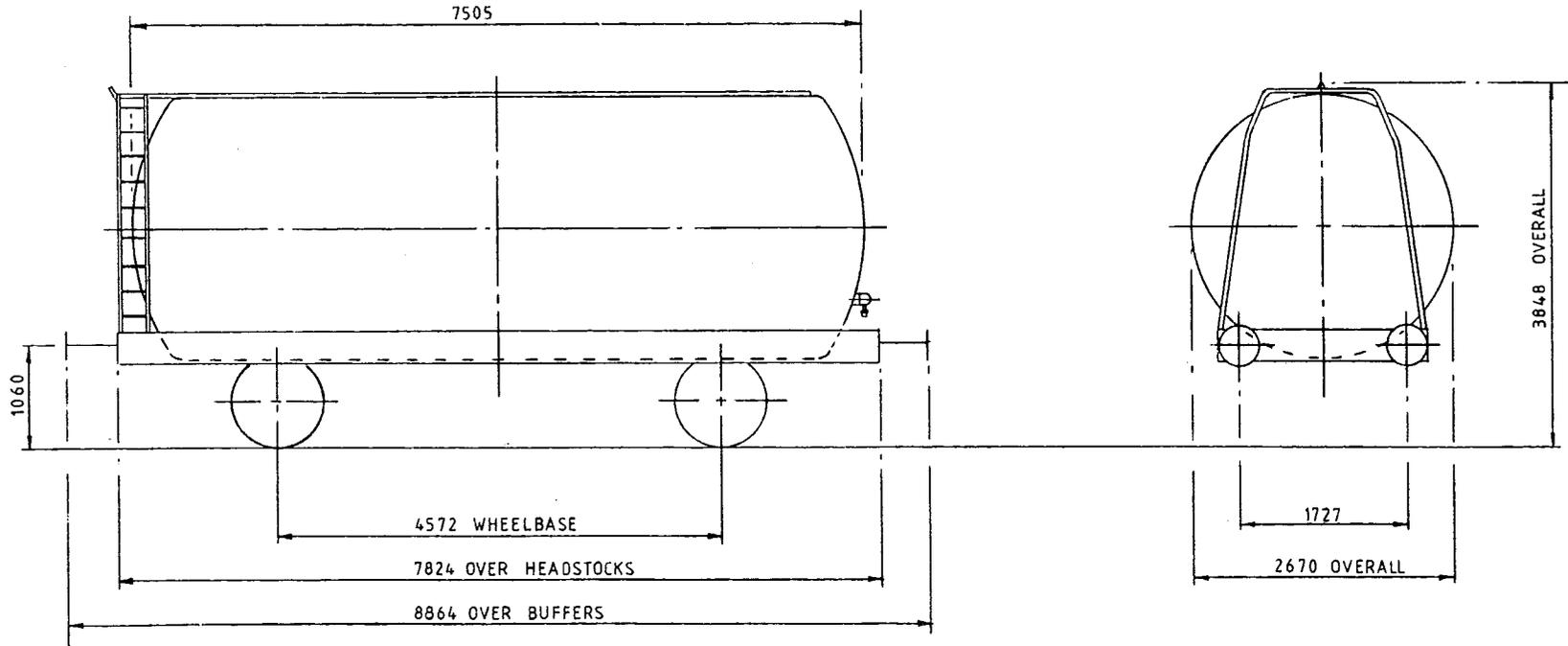

TARE-	13,800 Kg
CAPACITY, WEIGHT-	32,200 Kg
CAPACITY, VOLUME-	39,414 litres
MIN. CURVE-	31m
GEN. ARRGT. DRG. NO.-	

BRAKE-	AIR BLOCK & HAND LEVER
SUSPENSION-	DOUBLE LINK & PARABOLIC SPRING
COUPLINGS-	INSTANTER
BUFFERS-	HYDRAULIC 406 DIA HEADS
WHEELS-	952 DIA
JOURNALS-	140 DIA ROLLER BEARINGS

ISSUE 1

46 tonne GLW TANK WAGON-CLASS 'A'

LOT NUMBER	

TOPS INFORMATION											
AARKND		OPERATING		OPERATING SPEED			BRAKE FORCE DATA		EXCESS LENGTH	RA (GLW)	DESIGN SHEET
CARKND		PANEL No.		45 mile/h UP TO		14 tonne GLW	5 t FORCE UP TO		4	9	W1119
T	T	A	A	60 mile/h ABOVE			23 t FORCE ABOVE				

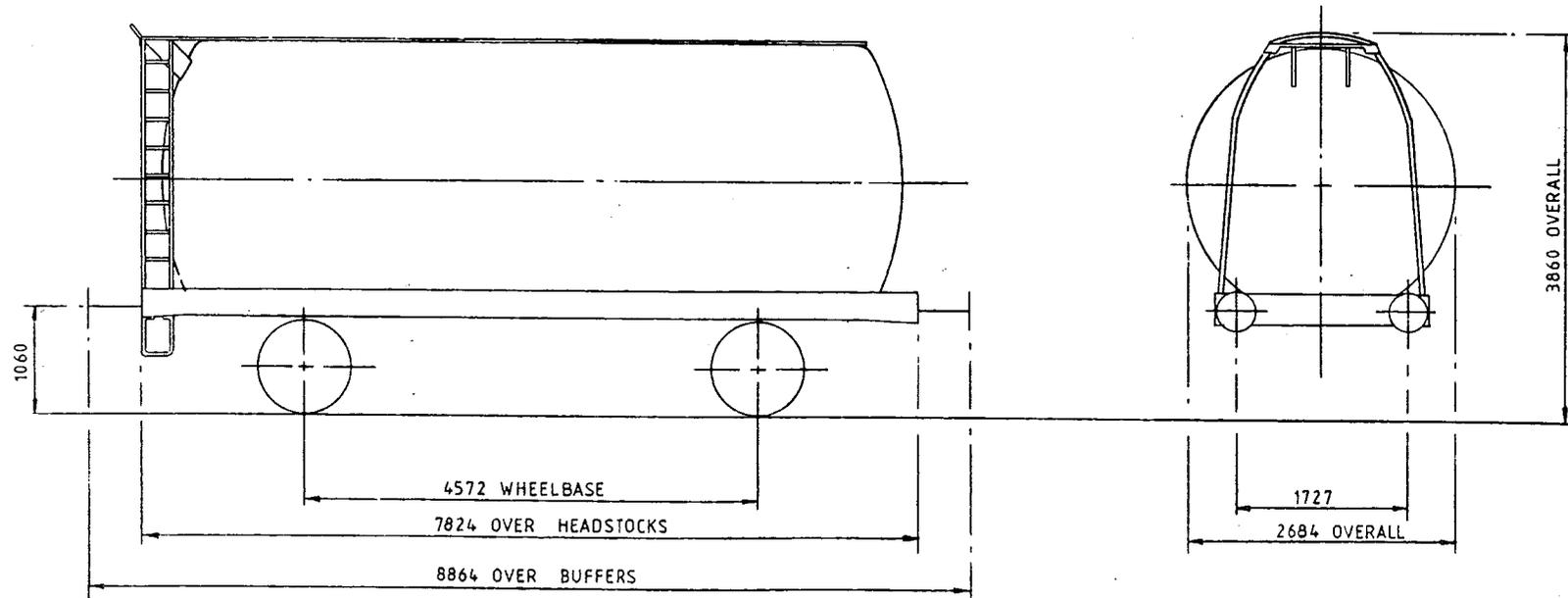

TARE-	13.600 Kg
CAPACITY, WEIGHT-	32.400 Kg
CAPACITY, VOLUME-	38.450 litres
MIN. CURVE-	31m
GEN. ARRGT. DRG. NO.-	

BRAKE-	AIR BLOCK & HAND LEVER
SUSPENSION-	DOUBLE LINK
COUPLINGS-	INSTANTER
BUFFERS-	HYDRAULIC 406 DIA HEADS
WHEELS-	952 DIA
JOURNALS-	140 DIA ROLLER BEARINGS

ISSUE 1

46 tonnes G.L.W. TANK WAGON

TTO20A

EXCESS LENGTH 4	H	M	L	E
tonnes	46	46	15	15
VB	18	18	8	8
AB				
RA	8	8	1	1
MAX. SPEED	60	60	45	45

TOPS CODE						
CARKND	AARKND		OPERATING PANEL No			
T	T	V	T	T	V	A
			1	4	4	4

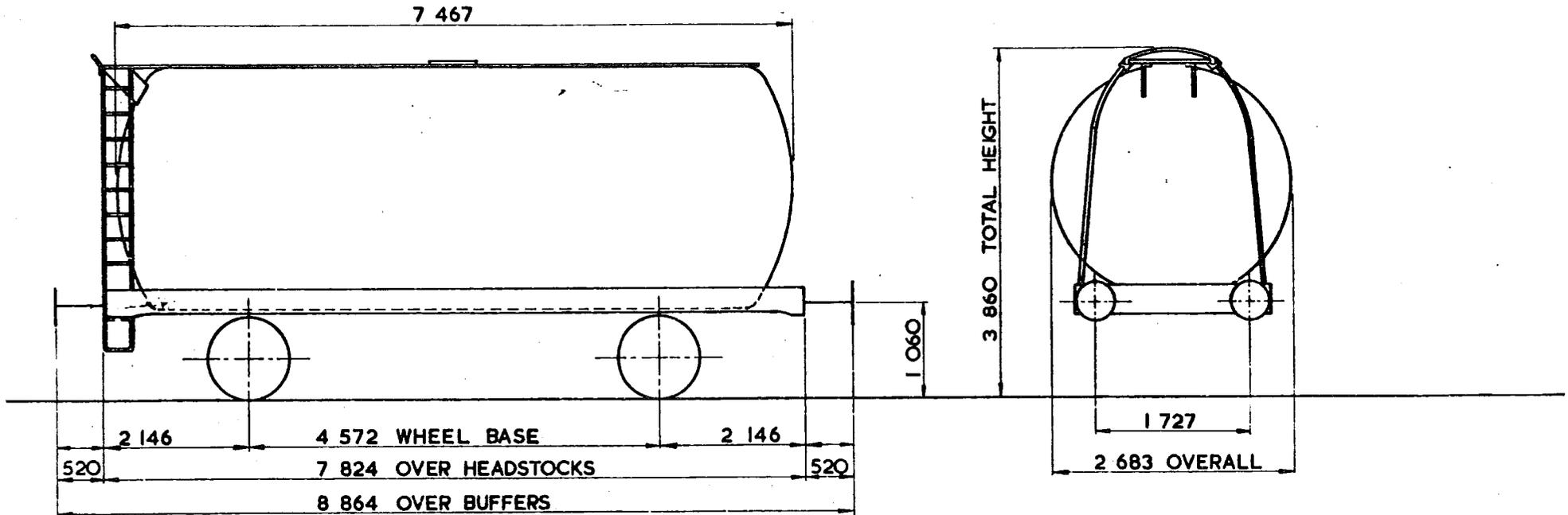

TARE -	14750kg
CARRYING CAPACITY -	31200kg
CAPACITY -	39018 litres
MAX. SPEED -	60 mile/h
WHEELS -	952 DIA.
JOURNALS -	140 DIA. ROLLER BEARINGS

BUFFERS -	HYDRAULIC 406 DIA. HEADS
COUPLINGS -	INSTANTER
MIN. CURVE -	31m
GEN. ARRGT. DRG. No. -	
BRAKE -	VACUUM BLOCK & HAND LEVER
SUSPENSION -	DOUBLE LINK

ISSUE 2
EX. PO. DIAGRAM 6/225 (ALLOCATED)

46 tonnes G. L. W. TANK WAGON

TTO20B

EXCESS LENGTH 4	H	M	L	E
tonnes	46	46	14	14
VB	18	18	8	8
AB				
RA	8	8	1	1
MAX. SPEED	60	60	45	45

TOPS CODE										
CARKND		AARKND			OPERATING PANEL No					
T	T	F	T	T	F	A	1	4	4	5

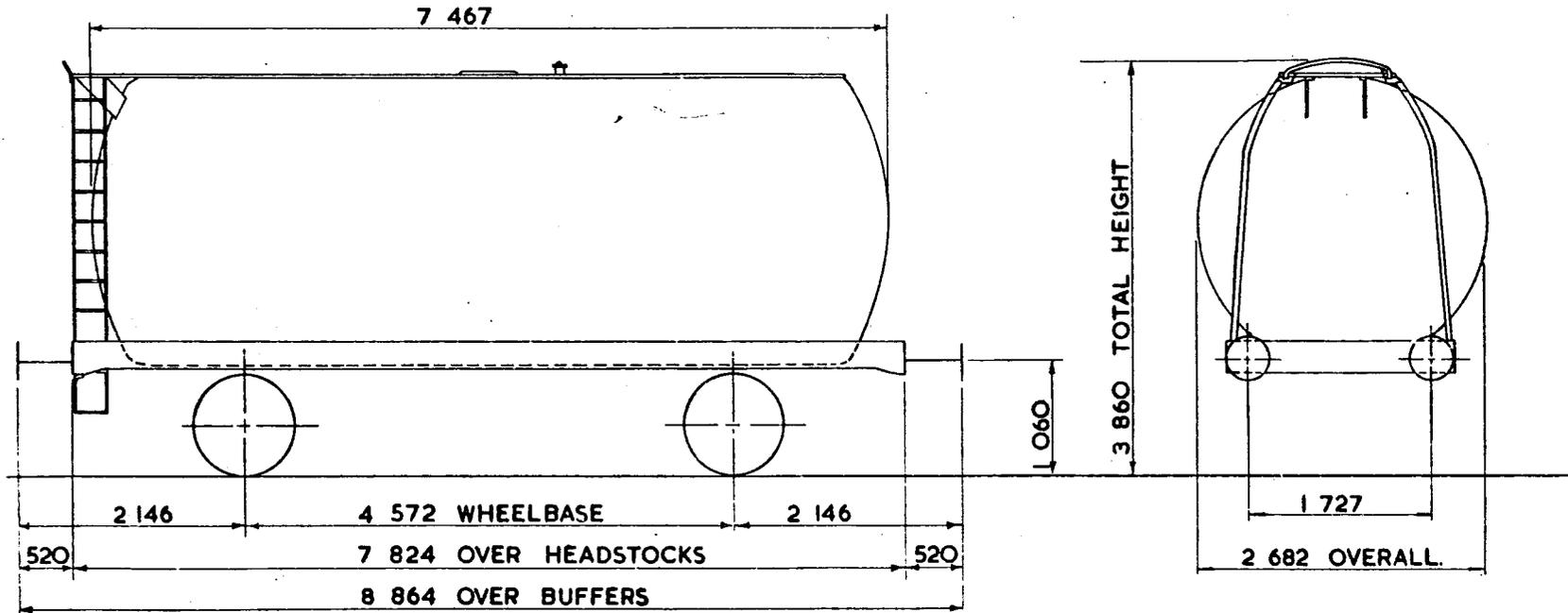

TARE - 13 700 kg.
CARRYING CAPACITY - 32 300
CAPACITY - 39 018 litres.
MAX. SPEED - 60 mile/h.
WHEELS - 952 DIA.
JOURNALS - 140 DIA. ROLLER BEARINGS

BUFFERS - HYDRAULIC 406 DIA. HEADS
COUPLINGS - INSTANTER
MIN. CURVE - 31m.
GEN. ARRGT. DRG. No -
BRAKE - VACUUM BLOCK & HAND LEVER.
SUSPENSION - DOUBLE LINK

BUILDER - CHARLES ROBERTS
OWNER - TIGER RAILCAR LEASING
REGISTERED BY - C.M. & E.E. (B.R.B.) DERBY.
YEAR BUILT 1965
REGISTRATION Nos - 51382 TO 51407
OWNERS Nos. - A 382 TO A 407

EX. P.O. DIAGRAM 6/137

46 tonnes G.L.W. TANK WAGON

TTO20C

DESIGN SHEET No. W.571

EXCESS LENGTH 4	H	M	L	E
tonnes	46	46	14	14
VB	0	0	0	0
AB	27	27	10	10
RA	8	8	1	1
MAX SPEED	60	60	60	60

TOPS CODE					
CARKND	AARKND	OPERATING PANEL NO.			
T	T	B	T	B	A
					1 3 5 6

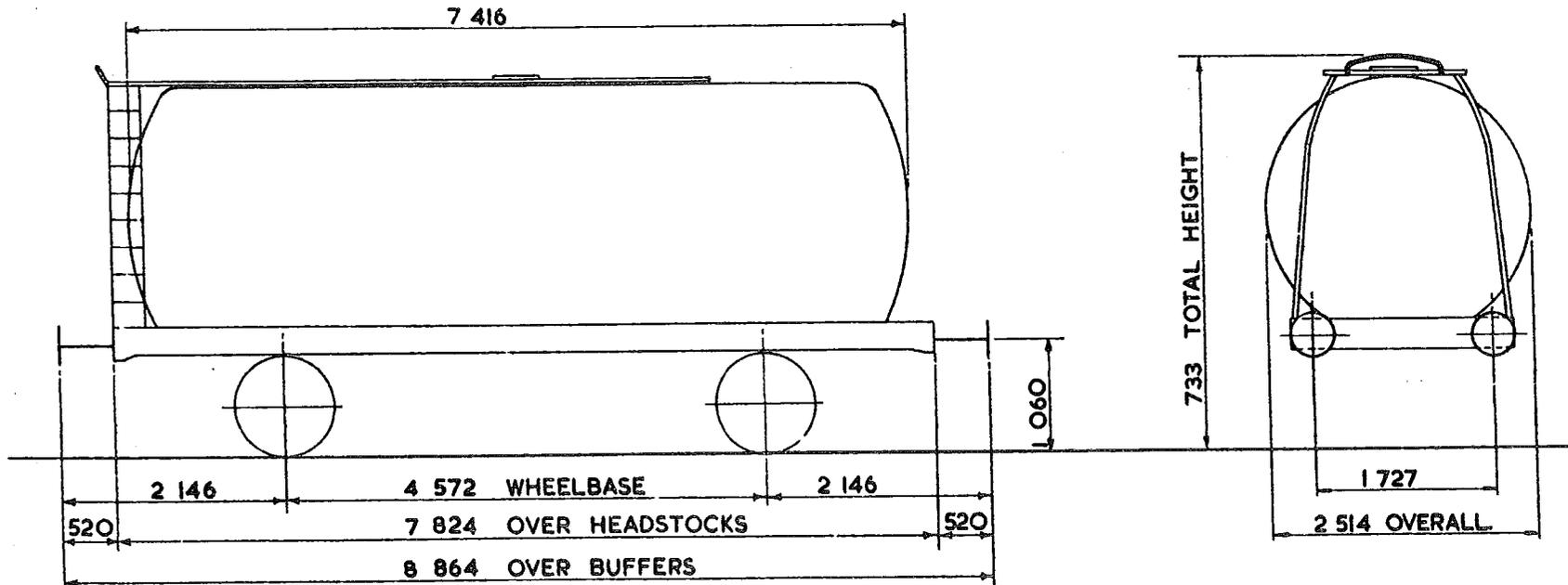

WGT 14 000 kg.
 CARRYING CAPACITY - 32 000 kg
 CAPACITY - 31 222 litres.
 SPEED 60 mile/h.
 DIA. 952 DIA.
 140 DIA. ROLLER BEARINGS

BUFFERS - HYDRAULIC 406 DIA. HEADS
 COUPLINGS INSTANTER
 MIN CURVE 31m.
 GEN ARRGT DRG No.
 BRAKE VACUUM BLOCK & HAND LEVER.
 SUSPENSION GLOUCESTER PEDESTAL

BUILDER - CHARLES ROBERTS
 OWNER - TIGER RAILCAR LEASING.
 REGISTERED BY C.M. & E.E. (B.R.B.) DERBY.
 YEAR BUILT 1965
 REGISTRATION NOS 51408 & 51409
 OWNERS NOS A 408 & A 409

ISSUE 3.

EX. P.O. DIAGRAM 6 / 138

46 tonnes G. L. W. TANK WAGON

TT020 D

EXCESS LENGTH 4	H	M	L	E
tonnes	46	46	14	14
VB	18	18	8	8
AB				
RA	8	8	1	1
MAX. SPEED	60	60	45	45

TOPS CODE		
CARKND	AARKND	OPERATING PANFL No
T T F	T T F A	I 4 4 5

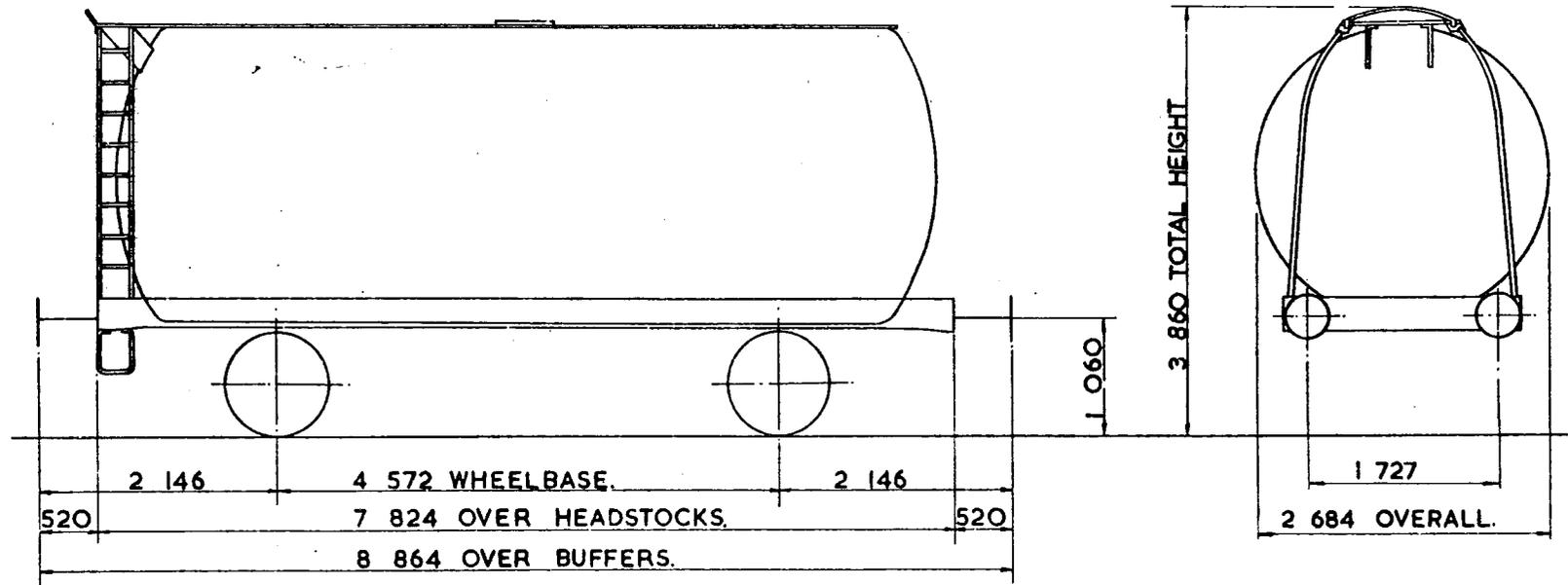

TARE - 13700kg.
CARRYING CAPACITY - 32 300 kg.
CAPACITY - 38459 litres.
MAX. SPEED - 60 mile/h.
WHEELS - 952 DIA.
JOURNALS - 140 DIA. ROLLER BEARINGS.

BUFFERS - HYDRAULIC 406 DIA. HEADS
COUPLINGS - INSTANTER.
MIN. CURVE - 31m.
GEN. ARRGT. DRG. No. -
BRAKE - VACUUM BLOCK & HAND LEVER.
SUSPENSION - DOUBLE LINK.

BUILDER - CHARLES ROBERTS.
OWNER - TEXACO
REGISTERED BY - C.M. & E.E. (B.R.B.) DERBY.
YEAR BUILT - 1965
REGISTRATION Nos. - 54812 TO 54834.
OWNERS Nos. -

ISSUE 2

EX. P. O. DIAGRAM 6/226 (ALLOCATED)

46 tonnes GLW TANK WAGON

TTO2OE

EXCESS LENGTH	4	H	M	L	E
tonnes	46	46	14	14	
VB	18	18	8	8	
AB					
PA	8	8	1	1	
MAX SPEED	60	60	45	45	

TOPS CODE										
CARKND			AARKND			OPERATING PANEL No.				
T	T	V	T	T	V	A	1	4	4	6

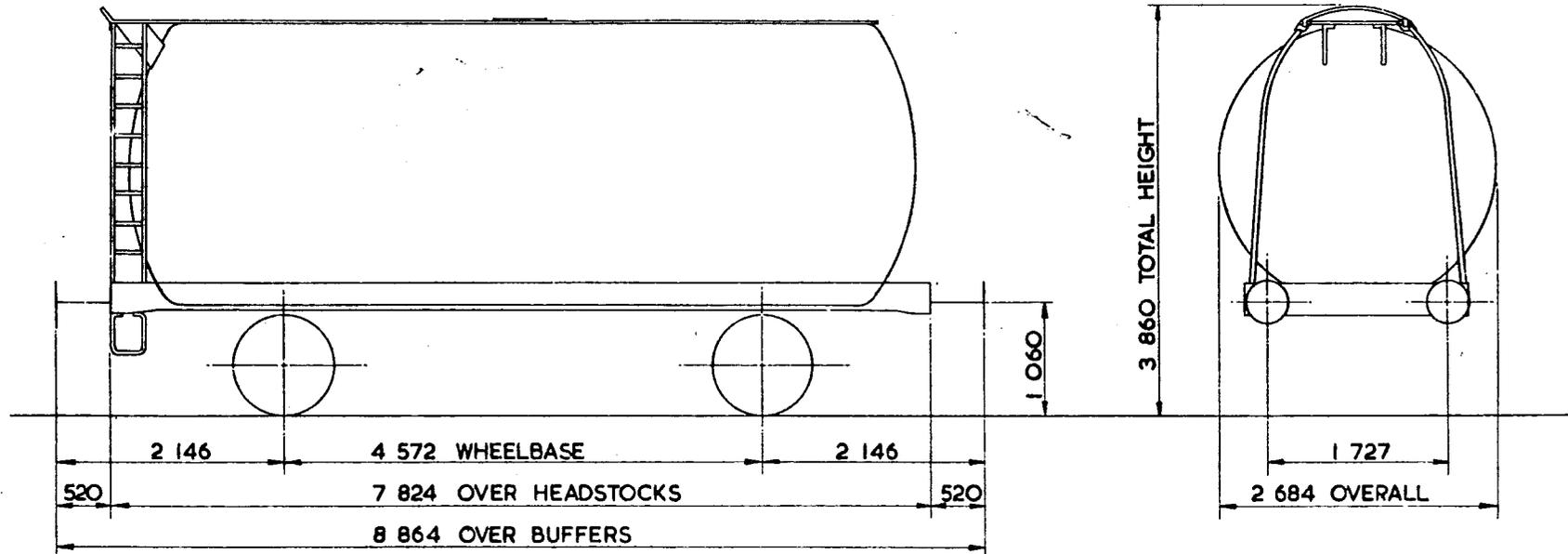

TARE --	13 700 kg
CARRYING CAPACITY --	32 300 kg
CAPACITY --	38 459 litres
MAX. SPEED --	60 mile/h
WHEELS --	952 DIA.
JOURNALS --	140 DIA. ROLLER BEARINGS

BUFFERS	HYDRAULIC 406 DIA. HEADS
COUPLERS	INSTANTER
WAGON LENGTH	31 m
GEN. APPROX. DRG. No.	
CONTROL	VACUUM BLOCK & HAND LEVER
SUSPENSION	DOUBLE LINK

BUILDER --	CHARLES ROBERTS
OWNER --	HARGREAVES FUEL OILS
REGISTERED BY --	C.M. & E.E./ (B.R.B) DERBY
YEAR BUILT --	1964
REGISTRATION Nos. --	53951 TO 53958
OWNERS Nos. --	

ISSUE 2

EX. PO. DIAGRAM 6/226 (ALLOCATED).

46 tonnes G.L.W. TANK WAGON

TT020F

EXCESS LENGTH	4	H	M	L	E
tonnes	46	46	14	14	
VB	21	21	8	8	
AB					
BA	8	8	1	1	
MAX SPEED	60	60	60	60	

TOP'S CODE									
CARKND	AARKND								
T	T	F	T	F	A	1	2	9	4

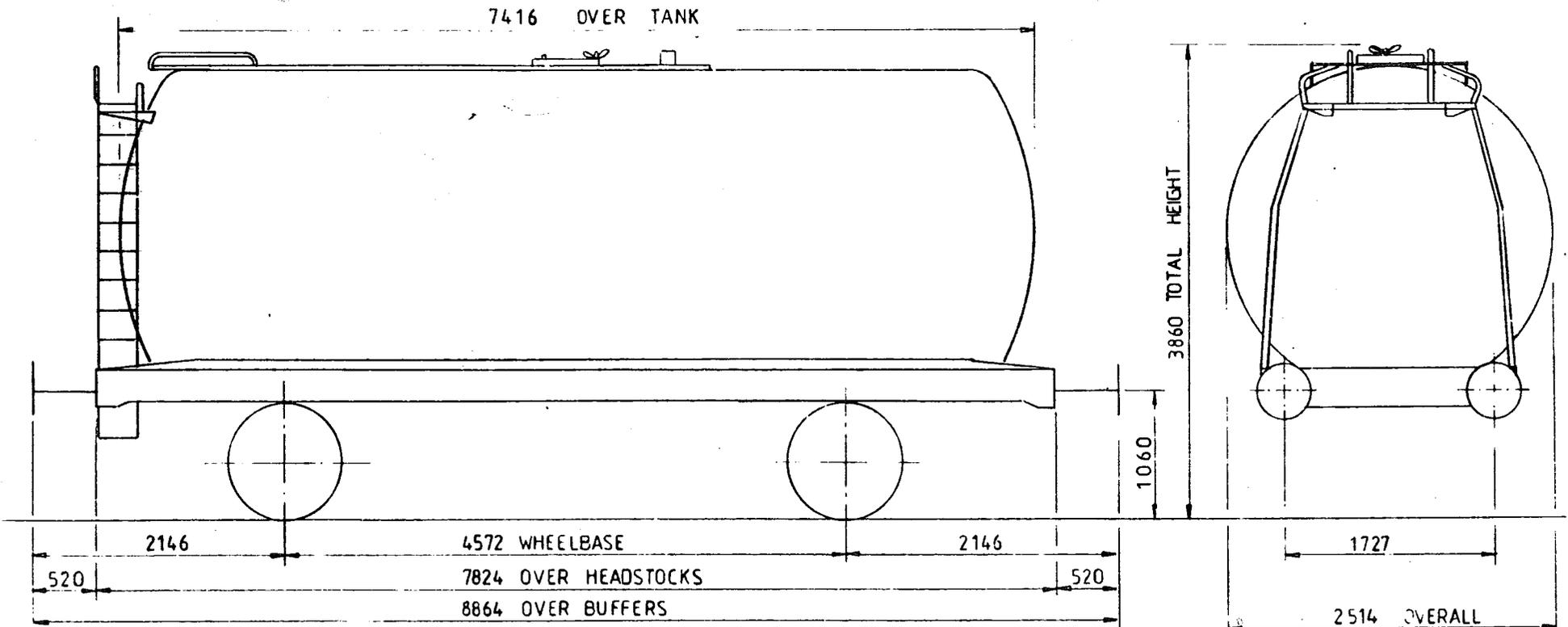

TARE	14 000 kg
CARRYING CAPACITY	32 000 kg
CAPACITY	31822 Litres
MAX SPEED	60 mile/h
WHEELS	Ø 952
JOURNALS	Ø140 ROLLER BEARINGS

BUFFERS	HYDRAULIC Ø406 HEADS
COUPLERS	INSTANTER
MIN CURVE	31 m
GEN ARRGT ORG N°	
BRAKE	A.F.I. VACUUM BLOCK & HAND LEVER
SUSPENSION	DOUBLE LINK

ISSUE 1

46 tonnes G.L.W. TANK WAGON – METHANOL

TTO21A

EXCESS LENGTH 5	H	M	L	E
tonnes	46	46	13	13
VB	0	0	0	0
AB	29	29	10	10
RA	8	8	1	1
MAX. SPEED	60	60	60	60

TOPS CODE		
CARKND	AARKND	OPERATING PANEL No
T	T	B
T	T	B
A	I	O
7	9	

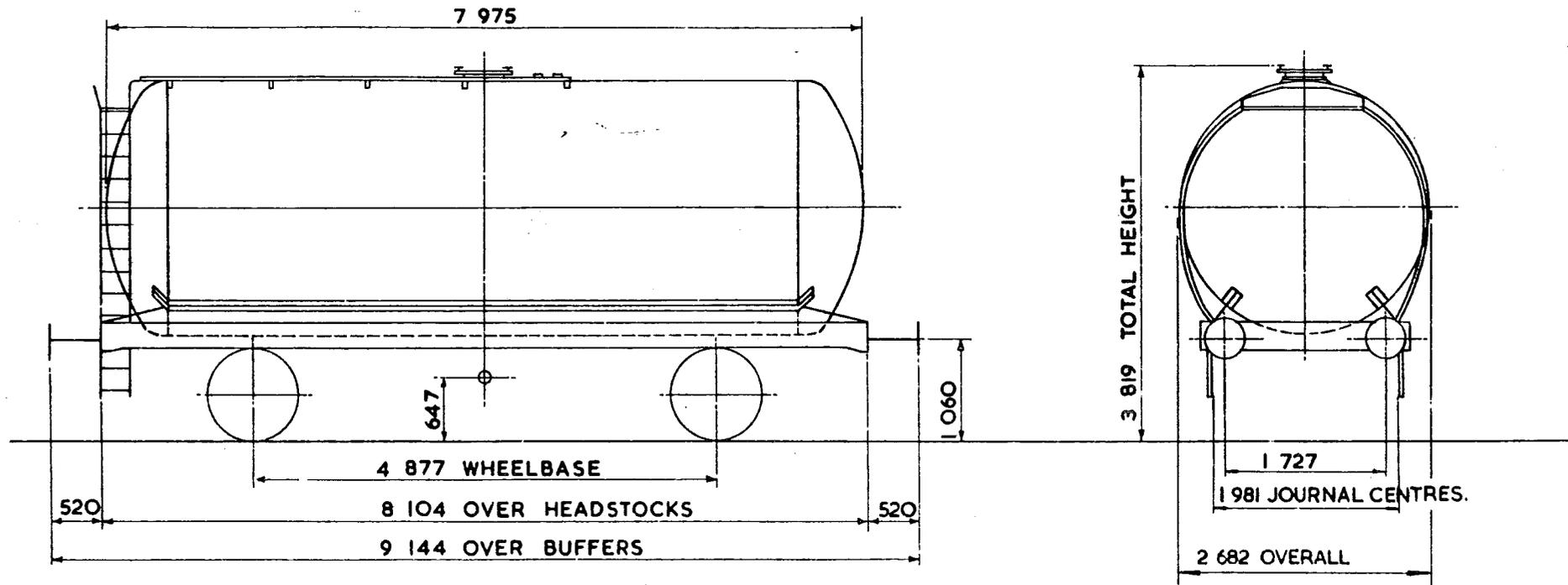

TARE – 13 250 kg.
CARRYING CAPACITY – 33 000 kg
CAPACITY – 43 000 litres.
MAX SPEED – 60 mile/h.
WHEELS – 952 DIA.
JOURNALS – 140 DIA. ROLLER BEARINGS

BUFFERS – HYDRAULIC 406 DIA. HEADS
COUPLINGS – INSTANTER
MIN. CURVE – 31m.
GEN. ARRGT. DRG. No. –
BRAKE – AIR BLOCK, VACUUM PIPED & HAND LEVER
SUSPENSION – DOUBLE LINK

BUILDER – STANDARD RAILWAY WAGON CO.
OWNER – I.C.I. AGRICULTURAL DIV. BILLINGHAM
REGISTERED BY – C.M. & E.E. (B.R.B.) DERBY.
YEAR BUILT – 1970
REGISTRATION Nos – 54351 TO 54380
OWNERS Nos – ML1001 TO ML1030

46 tonnes G.L.W. TANK WAGON-CLASS A

TTO2IB

EXCESS LENGTH	5	H	M	L	E
tonnes.	46	46	13	13	
VB	0	0	0	0	
AB	29	29	10	10	
RA	8	8	1	1	
MAX SPEED	60	60	60	60	

TOPS CODE		
CARKND	AARKND	OPERATING PANEL No
T T B	T T B A	I O 6 4

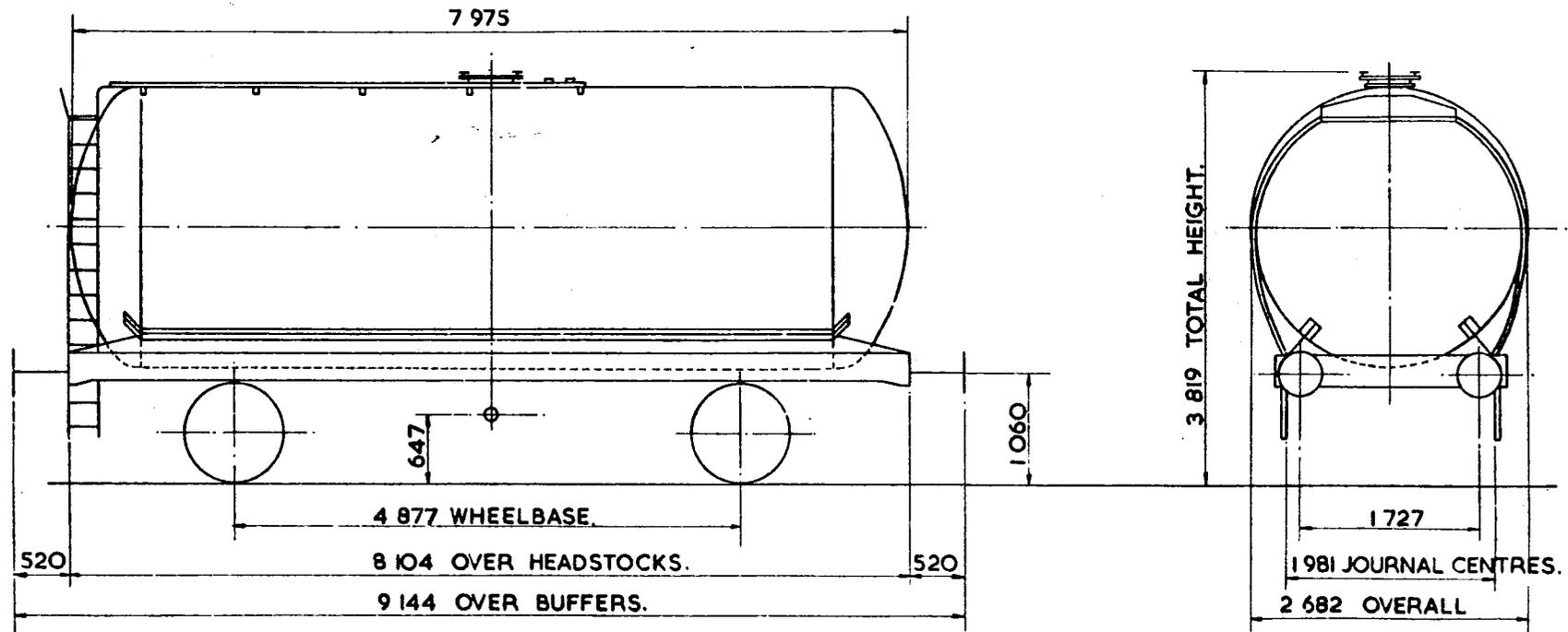

TARE -	13100kg.
CARRYING CAPACITY-	32900kg.
CAPACITY-	43005 litres.
MAX. SPEED -	60 mile/h.
WHEELS -	952 DIA.
JOURNALS -	140 DIA. ROLLER BEARINGS.

BUFFERS -	HYDRAULIC 406 DIA. HEADS.
COUPLINGS -	INSTANTER.
MIN. CURVE -	31m.
GEN. ARRGT DRG. No. -	
BRAKE -	AIR BLOCK VACUUM PIPED & HAND LEVER.
SUSPENSION -	DOUBLE LINK.

BUILDER -	STANDARD RAILWAY WAGON CO.
OWNER -	PROCOR (U.K.) LTD.
REGISTERED BY -	C.M. & E.E. (B.R.B.) DERBY.
YEAR BUILT -	1969
REGISTRATION Nos. -	58136 TO 58155
OWNERS Nos. -	136 TO 155.

ISSUE 2
EX. PO. DIAGRAM 3/135.

46 tonnes G.L.W. TANK WAGON-HYDROCYANIC ACID.

TTO22C

EXCESS LENGTH 4	H	M	L	E
tonnes.	46	46	23	23
VB	0	0	0	0
AB	28	28	12	12
RA	8	8	1	1
MAX. SPEED	35	35	35	35

TOPS CODE										
CARKND			AARKND			OPERATING PANEL No				
T	T	B	T	T	B	A	1	4	4	8

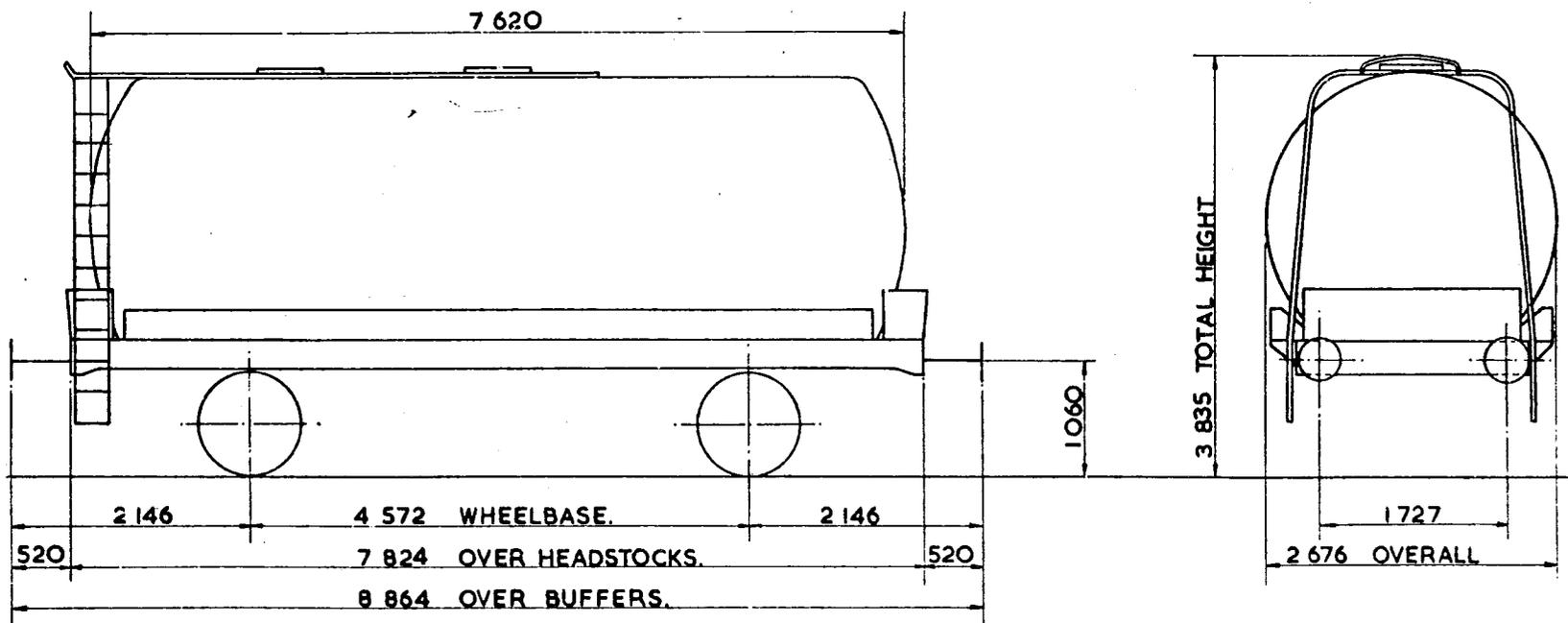

TARE --	22350kg.
CARRYING CAPACITY --	23600kg.
CAPACITY --	33500litres.
MAX. SPEED --	35 mile/h.
WHEELS --	952 DIA.
JOURNALS --	140 DIA. ROLLER BEARINGS.

BUFFERS --	HYDRAULIC 406 DIA. HEADS.
COUPLINGS --	INSTANTER.
MIN. CURVE --	31m.
GEN. ARRGT. DRG. No. --	
BRAKE --	AIR BLOCK, VACUUM PIPED & HAND LEVER
SUSPENSION --	DOUBLE LINK.

BUILDER --	CHARLES ROBERTS.
OWNER --	TIGER RAILCAR LEASING.
REGISTERED BY --	CM.&E.E. (B.R.B) DERBY.
YEAR BUILT --	1965
REGISTRATION Nos. --	51435 TO 51449 (RANGE)
OWNERS Nos. --	51435 TO 51449 (RANGE)

ISSUE 2
EX. P.O. DIAGRAM 6/139

46 tonne GLW. TANK WAGON HYDROCYANIC ACID

TT 022 D

EXCESS LENGTH	4	H	M	L	E
tonnes	46	46	23	23	
VB	0	0	0	0	
AB	22	22	12	12	
RA	8	8	1	1	
MAX. SPEED	45	45	45	45	

TOPS CODE										
CARKND	AARKND			OPERATING PANEL No						
T	T	B	T	T	B	A	1	4	4	9

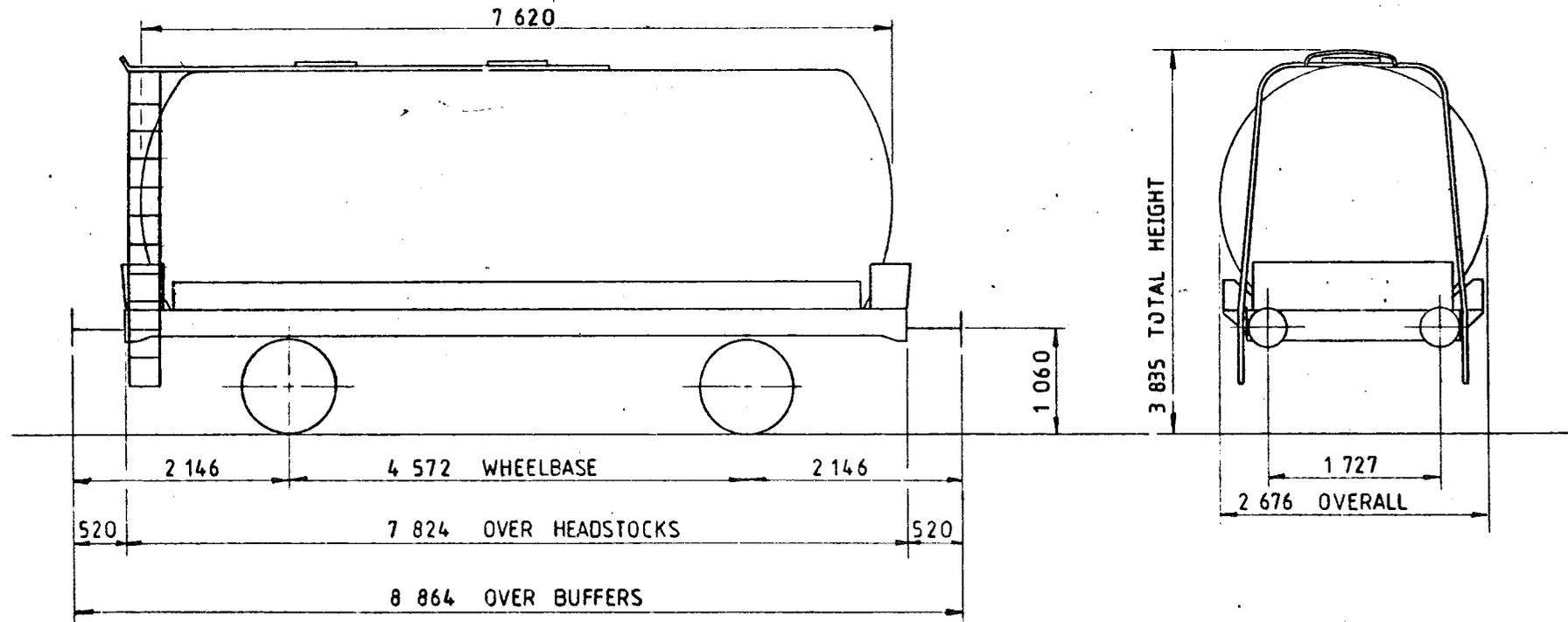

TARE -	22 850 kg
CARRYING CAPACITY -	23 600 kg
CAPACITY -	33 500 litres
MAX. SPEED -	45 mile/h
WHEELS -	952 DIA.
JOURNALS -	140 DIA. ROLLER BEARINGS

BUFFERS -	HYDRAULIC 406 DIA. HEADS
COUPLINGS -	INSTANTER
MIN. CURVE -	31 m
GEN. ARRGT. DRG No. -	
BRAKE -	AIR BLOCK, VACUUM PIPED & HAND LEVER
SUSPENSION -	GLOUCESTER PEDESTAL

issue 1

46 tonnes G.L.W. TANK WAGON

TT022H

EXCESS LENGTH	4	H	M	L	E
tonnes	46	46	13	13	
VB					
AR	22	22	12	12	
MA	8	8	1	1	
MAX SPEED	60	60	45	45	

TOPS CODE										
CARKND			AARKND			OPERATION PANEL				
T	T	A	T	T	A	A	1	6	2	8

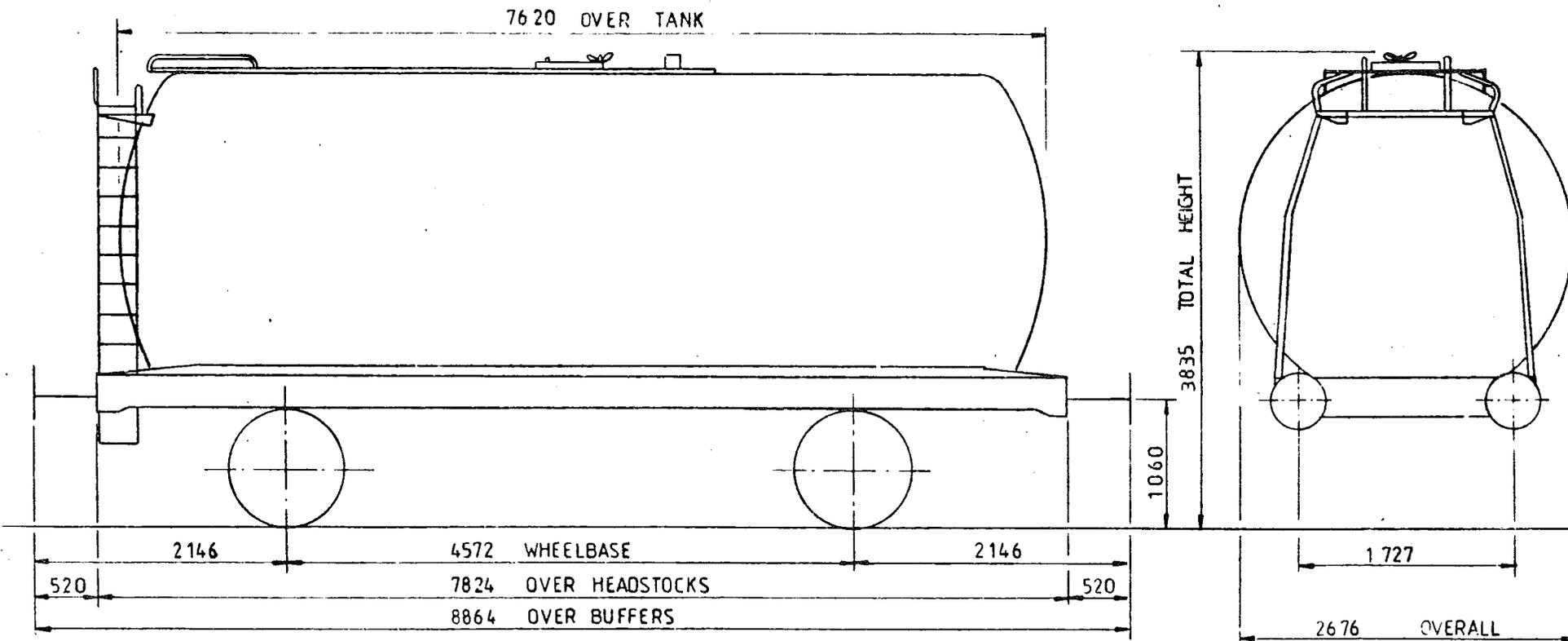

TARE	13100 kg
CARRYING CAPACITY -	32900 kg
CAPACITY -	24957 Litres
MAX SPEED	60 mile/h
WHEELS	Ø 952
JOURNALS	Ø140 ROLLER BEARINGS

BUFFERS	HYDRAULIC Ø406 HEADS
COUPLINGS	INSTANTER
MIN CURVE	31 m
GEN ARRGT DRG No	
BRAKE	AIR BLOCK HAND LEVER
SUSPENSION	.FAT 28

ISSUE 1

46 tonnes G.L.W. TANK WAGON

TT022J

EXCESS LENGTH	4	H	M	L	E
tonnes	46	46	14	14	
VB					
AB	22	22	12	12	
RA	8	8	1	1	
MAX SPEED	60	60	45	45	

TOPS CODE		
CARKND	AARKND	
T	T	A A 1 6 2 8

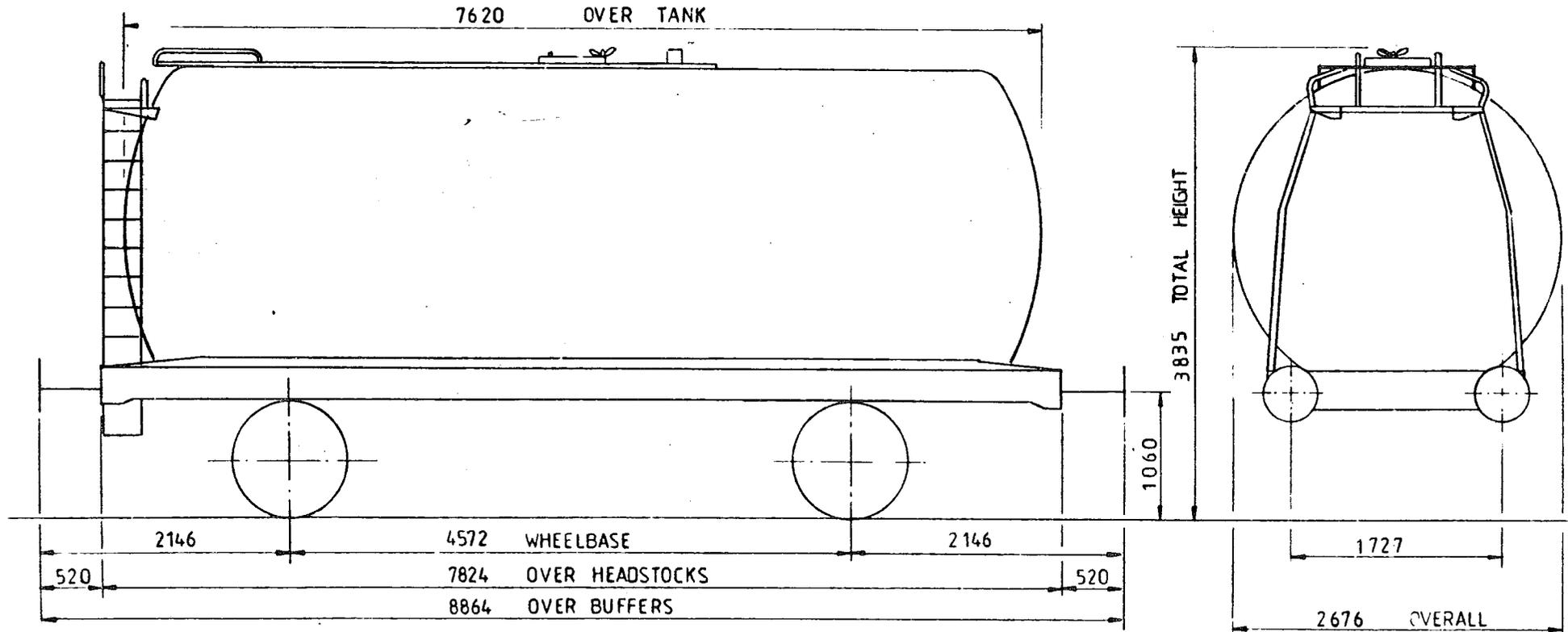

TARE	14 100 kg
CARRYING CAPACITY -	31 900 kg
CAPACITY -	24 957 Litres
MAX SPEED	60 mile/h
WHEELS	φ 952
JOURNALS	φ140 ROLLER BEARINGS

BUFFERS	HYDRAULIC φ406 HEADS
COUPLINGS	INSTANTER
MIN CURVE	31 m
GEN ARRGT DRG No	
BRAKE	AIR BLOCK, HAND LEVER
SUSPENSION	GLOUCESTER PEDESTAL

ISSUE 1

EX P.O. DIAGRAM 6/139 (ALLOCATED)

46 tonnes G. L.W. TANK WAGON

TTO23B

EXCESS LENGTH	4	H	M	L	E
tonnes	46	46	13	13	
VB	0	0	0	0	
AB	22	22	9	9	
RA	8	8	1	1	
MAX SPEED	60	60	45	45	

TOPS CODE									
CARKND		AARKND			OPERATING PANEL No.				
T	T	B	T	B	A	1	4	5	0

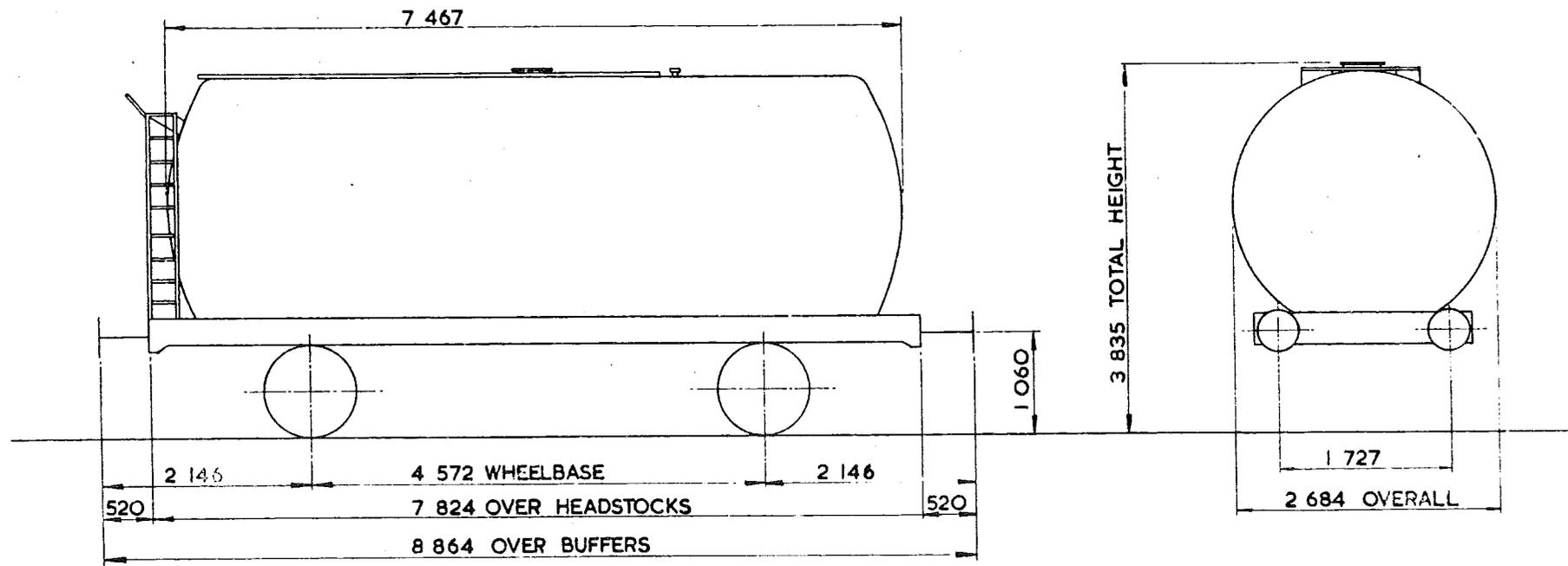

TARE - 13200 kg.
CARRYING CAPACITY - 32800 kg.
CAPACITY - 39614 litres.
MAX SPEED - 60 mile/h
WHEELS - 952 DIA
JOURNALS - 140 DIA ROLLER BEARINGS

BUFFERS - HYDRAULIC 406 DIA HEADS
COUPLINGS - INSTANTER
MIN. CURVE - 31 m
GEN. ARRGT. DRG. No. -
BRAKE - AIR BLOCK, VACUUM PIPED & HAND LEVER.
SUSPENSION - DOUBLE LINK

BUILDER - CHARLES ROBERTS
OWNER - PETROFINA (U.K.) LTD.
REGISTERED BY - C.M. & E.E. (B.R.B.) DERBY
YEAR BUILT - 1966-67
REGISTRATION Nos. - 54701 TO 54730
OWNERS Nos. - 241 TO 270

ISSUE 2
EX. P.O. DIAGRAM 5/134 (ALLOCATED)

46 tonnes GL.W. TANK WAGON - CLASS 'A'

TTO24 A

EXCESS LENGTH	5	H	M	L	E
tonnes	46	46	13	13	
VB	0	0	0	0	
AB	26	26	9	9	
RA	8	8	1	1	
MAX SPEED	60	60	60	60	

TOPS CODE										
CARKND			AARKND			OPERATING PANEL No				
T	T	B	T	T	B	A	1	4	5	1

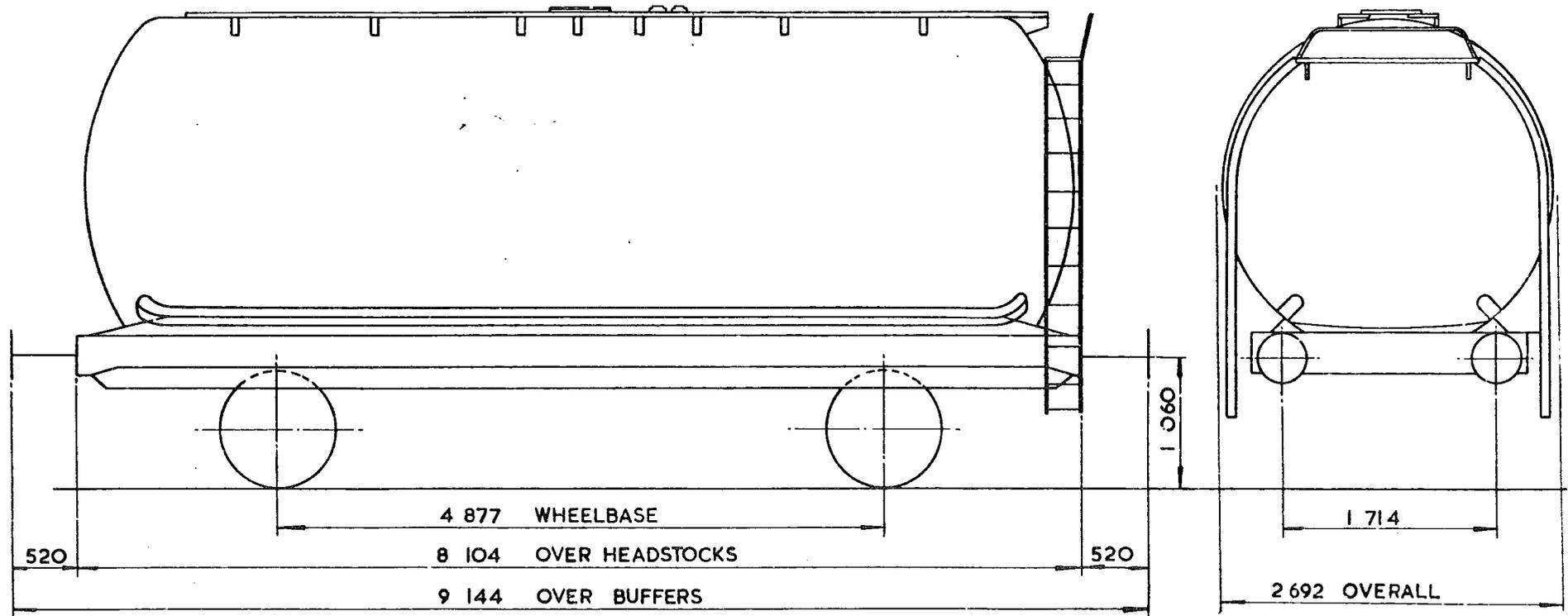

TARE - 13 200 kg
CARRYING CAPACITY - 32 000 kg
CAPACITY - 39 959 OR 40 641 litres
MAX SPEED - 60 mile/h
WHEELS - 952 DIA.
JOURNALS - 140 DIA. ROLLER BEARINGS

BUFFERS - HYDRAULIC 406 DIA. HEADS
COUPLINGS - INSTANTER
MIN. CURVE - 31 m
GEN. ARRGT. DRG. No. -
BRAKE - AIR BLOCK VACUUMPIPED & HAND LEVER
SUSPENSION - DOUBLE LINK

BUILDER - STANDARD RAILWAY WAGON Co.
OWNER - PROCOR (U.K.) LTD.
REGISTERED BY - C.M. & E.E.(B.R.B.) DERBY
YEAR BUILT - 1968
REGISTRATION Nos. - 58101 TO 58135
OWNERS Nos. - 101 TO 135

ISSUE 2

EX PO. DIAGRAM 6/690 (ALLOCATED)

46 tonne GLW TANK WAGON

LOT NUMBER	

TOPS INFORMATION						
AARKND	OPERATING	OPERATING SPEED		BRAKE FORCE DATA		EXCESS LENGTH
CARKND	PANEL No.	45 mile/h UP TO	16 tonne GLW	9t FORCE UP TO	31 tonne GLW	4
T	A	60 mile/h ABOVE		23t FORCE ABOVE		8
						W1511

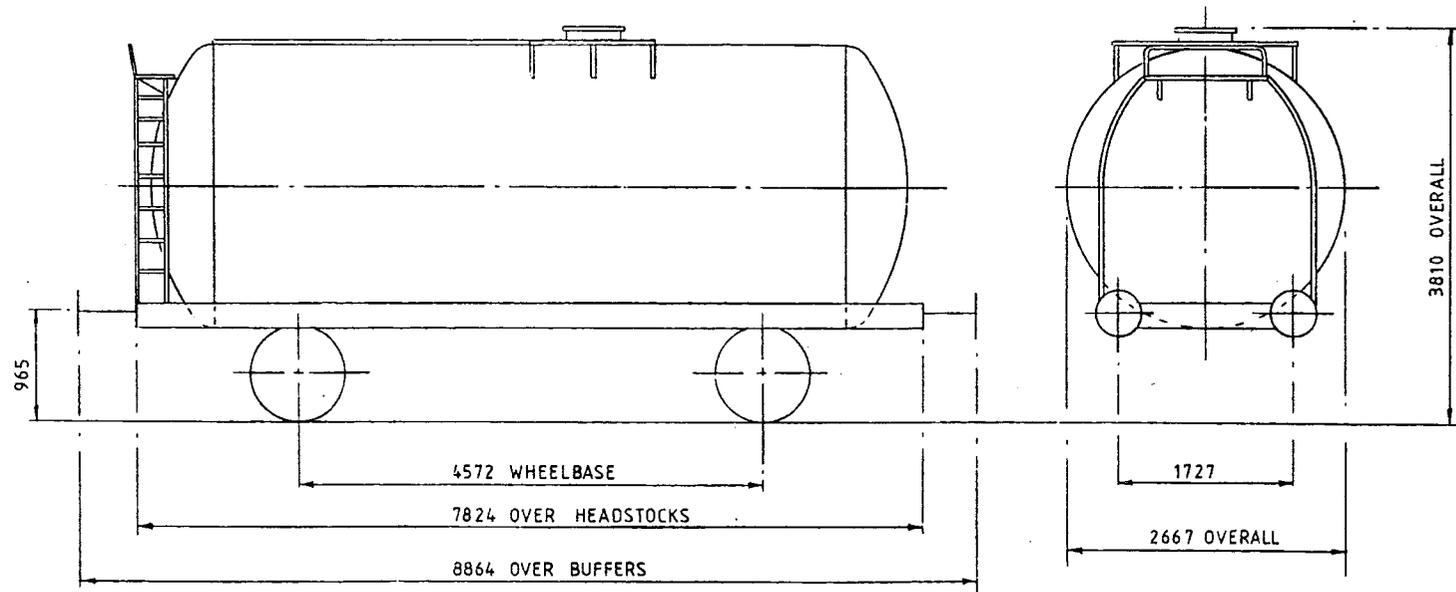

TARE-	15.200 Kg
CAPACITY, WEIGHT-	30.800 Kg
CAPACITY, VOLUME-	35.49' litres
MIN. CURVE-	31m
GEN. ARRGT. DRG. NO.-	

BRAKE-	AIR BLOCK & HAND LEVER
SUSPENSION-	DOUBLE LINK
COUPLINGS-	INSTANTER
BUFFERS-	HYDRAULIC 406 DIA HEADS
WHEELS-	952 DIA
JOURNALS-	140 DIA ROLLER BEARINGS

ISSUE 1

46 tonnes G.L.W. TANK WAGON - CLASS B - COILED

TTO26A

EXCESS LENGTH	5	H	M	L	E
tonnes	46	46	14	14	
VB	0	0	0	0	
AB	23	23	10	10	
RA	8	8	1	1	
MAX. SPEED	60	60	45	45	

TOPS CODE										
CARKND		AARKND		OPERATING PANEL No.						
T	T	B	T	T	B	A	1	4	5	3

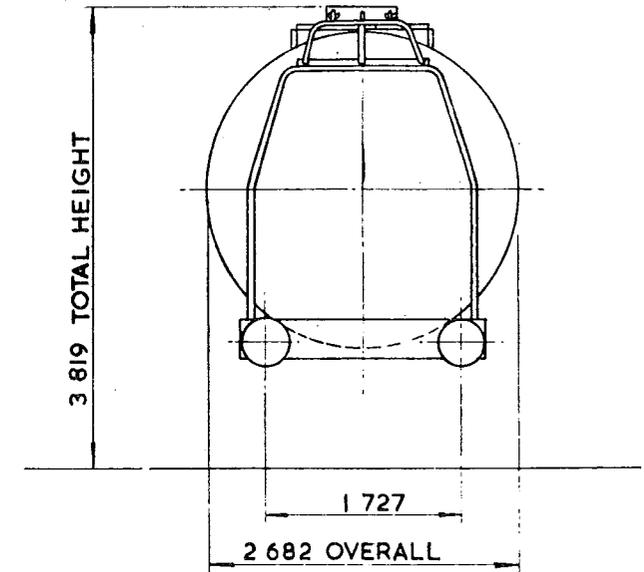
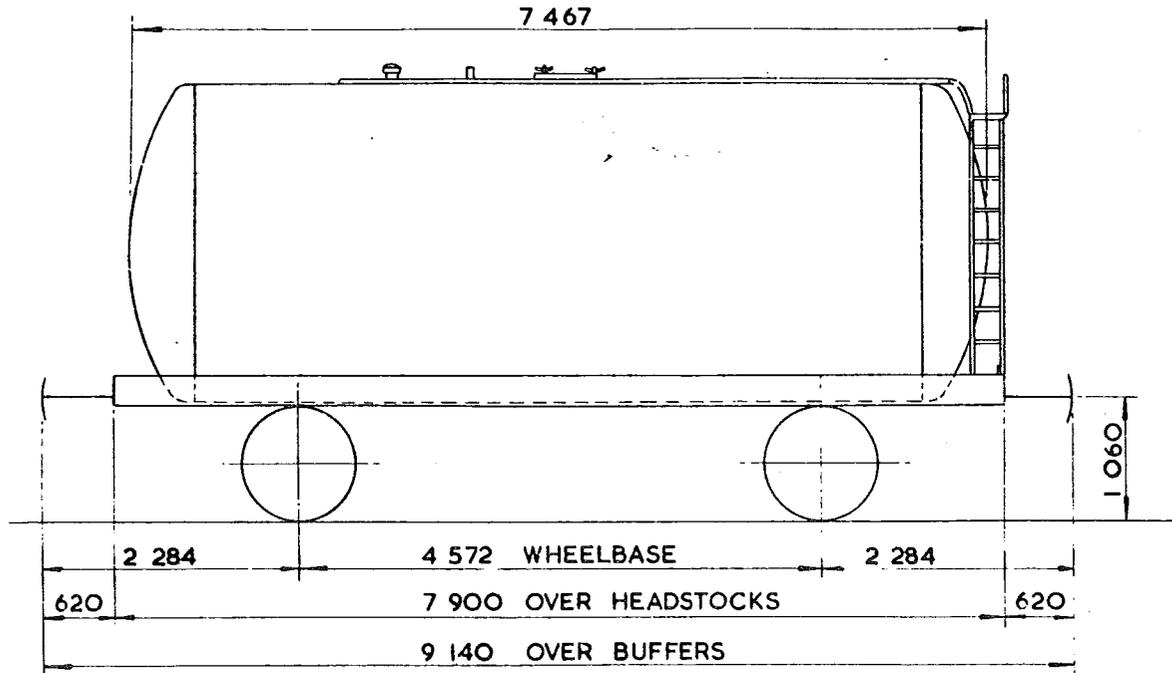

TARE -	13 450 kg
CARRYING CAPACITY -	32 500 kg
CAPACITY -	38 886 litres
MAX. SPEED -	60 mile/h
WHEELS -	952 DIA.
JOURNALS -	140 DIA ROLLER BEARINGS

BUFFERS -	HYDRAULIC 406 DIA. HEADS
COUPLINGS -	INTERNATIONAL SCREW
MIN. CURVE -	31 m
GEN. ARRGT. DRG. No. -	
BRAKE -	AIR BLOCK VACUUM PIPED & HAND LEVER
SUSPENSION -	DOUBLE LINK

BUILDER -	METRO - CAMELL
OWNER -	ALGECO
REGISTERED BY -	C.M. & E.E (B.R.B) DERBY
YEAR BUILT -	1967
REGISTRATION Nos. -	49317 TO 49364
OWNERS Nos. -	187884 TO 187932

ISSUE 2

EX PC. DIAGRAM 6/178

46 tonnes G.L.W. TANK WAGON - CLASS A

TTO26 B

EXCESS LENGTH	4	H	M	L	E
tonnes	46	46	13	13	
VB					
AB	22	22	10	10	
RA	8	8	1	1	
MAX. SPEED	60	60	45	45	

TOPS CODE										
CARKND			AARKND			OPERATING PANEL No				
T	T	A	T	T	A	A	1	4	5	4

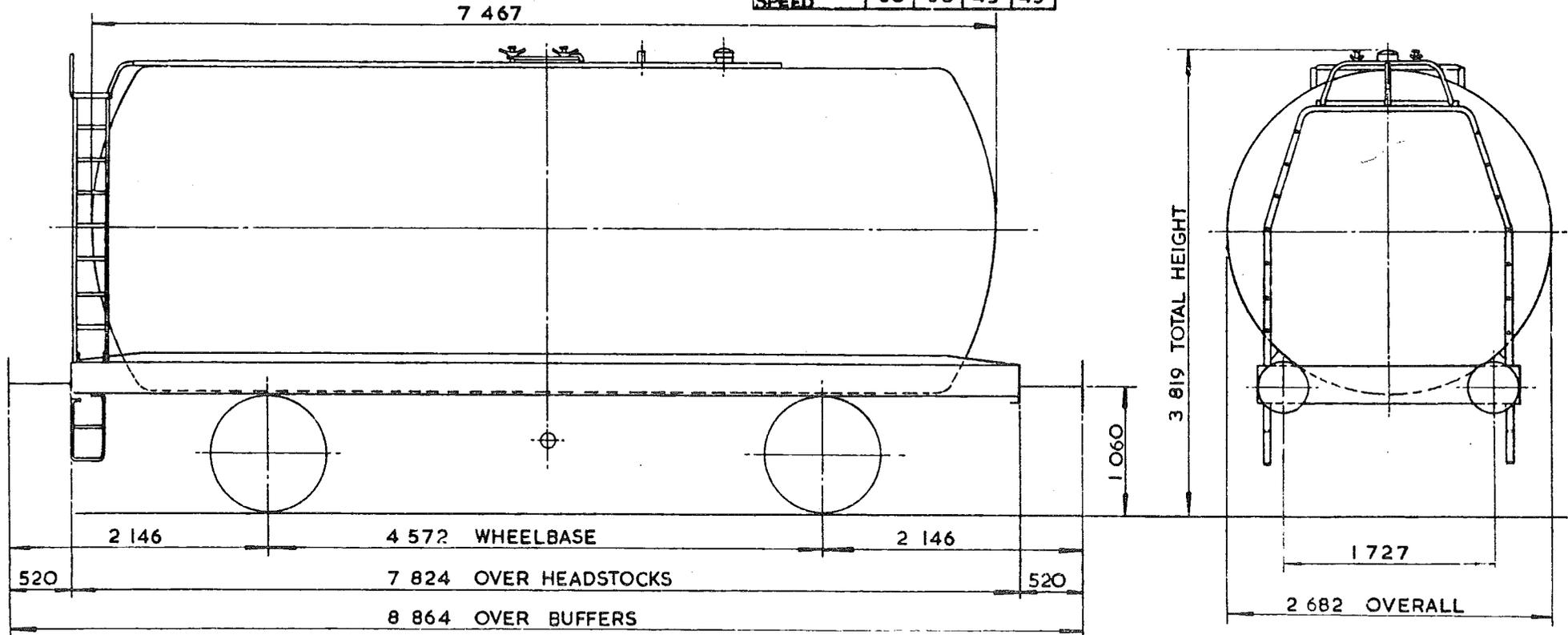

TARE - 12 800 kg
CARRYING CAPACITY - 33 200 kg
CAPACITY - 39 122 litres
MAX. SPEED - 60 mile/h
WHEELS - 952 DIA.
JOURNALS - 140 DIA. ROLLER BEARINGS

BUFFERS - HYDRAULIC 406 DIA. HEADS
COUPLINGS - INSTANTER
MIN. CURVE - 31 m
GEN. ARRGT. DRG. No. -
BRAKE - AIR BLOCK & HAND LEVER
SUSPENSION - DOUBLE LINK

BUILDER - METRO CAMELL
OWNER - BRITISH RAILWAY TRAFFIC & ELECTRIC
REGISTERED BY - C.M. & E.E. (B.R.B.) DERBY
YEAR BUILT - 1966
REGISTRATION Nos. - 57655-57660, 57662 & 57663
OWNERS Nos. - 10288 TO 10313

ISSUE 2
EX. PO. DIAGRAM 6/157

46 tonnes G.L.W. TANK WAGON - CLASS. A.

TTO26C

EXCESS LENGTH	4	H	M	L	E
tonnes	46	46	13	13	
VB	0	0	0	C	
AB	22	22	10	10	
RA	8	8	1	1	
MAX. SPEED	60	60	45	45	

TOPS CODE										
CARKND		AARKND			REMARKS PANELS					
T	T	B	T	T	B	A	1	4	5	5

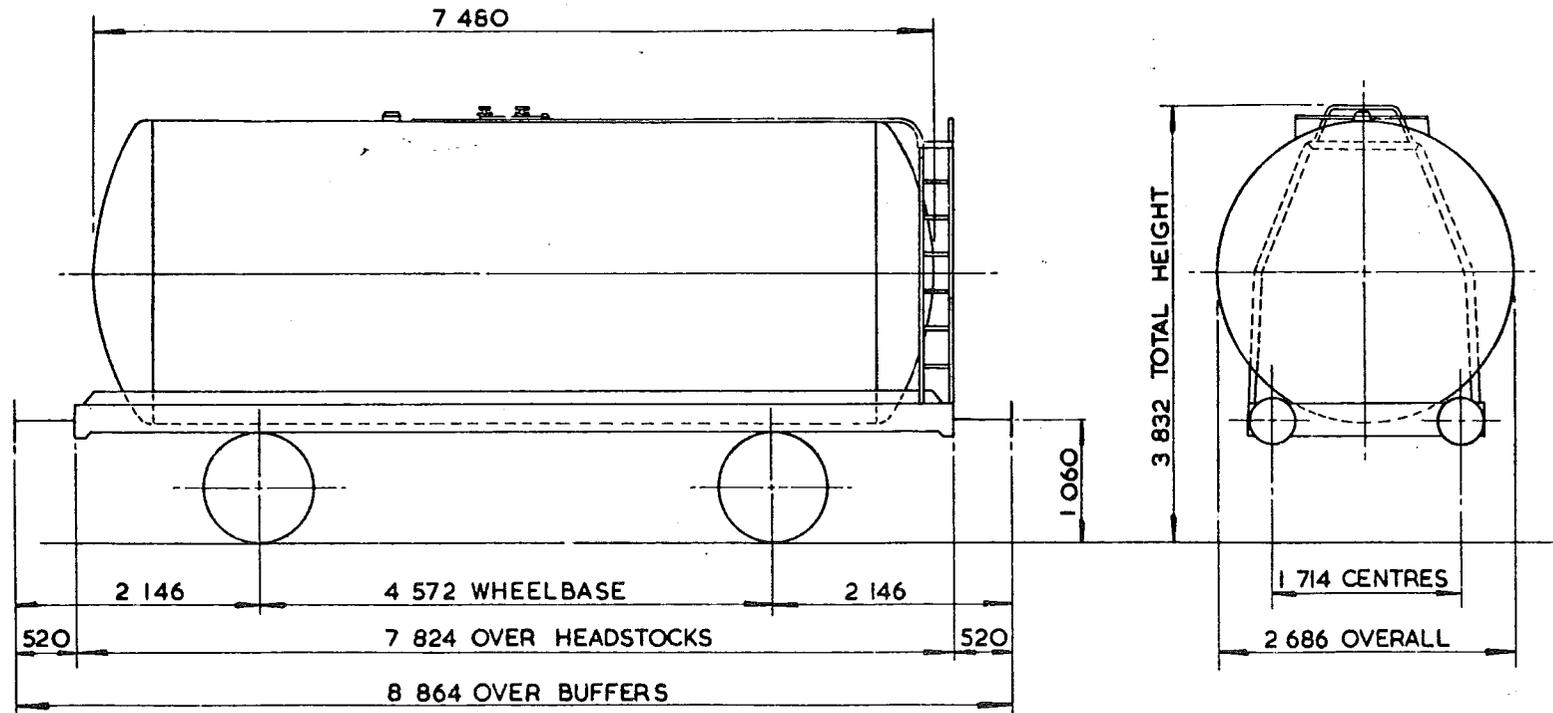

TARE -	13000kg
CARRYING CAPACITY -	33000kg
CAPACITY	38359 litres
MAX. SPEED	60mile/h
WHEELS -	952 DIA
JOURNALS -	140 DIA ROLLER BEARINGS

BUFFERS -	HYDRAULIC 406 DIA. HEADS
COUPLINGS -	INSTANTER
MIN. COUPLER -	31m
GEN. ARRGT. PRG. No. -	
BRAKE -	AIR BLOCK VACUUM PIPED HAND LEVER
SUSPENSION -	DOUBLE LINK

BUILDER -	METRO CAMELL
OWNER	SUKO & B.P.O.
REGISTERED BY -	CM. & E.E. (B.R.B.) DERBY
YEAR BUILT -	1967
REGISTRATION Nos. -	SUKO 60501 TO 60511 BPO 60560 TO 60568
OWNERS Nos. -	

ISSUE 2

EX. P.O. DIAGRAM 6/714 (ALLOCATED).

46 tonnes G.L.W. TANK WAGON - CLASS A

TTO26D

EXCESS LENGTH	4	H	M	L	E
tonnes	46	46	13	13	
VB	0	0	0	0	
AB	22	22	10	10	
RA	8	8	1	1	
MAX SPEED	60	60	45	45	

TOPS CODE										
CARKND			AARKND			OPERATING PANEL No.				
T	T	B	T	T	B	A	1	4	5	5

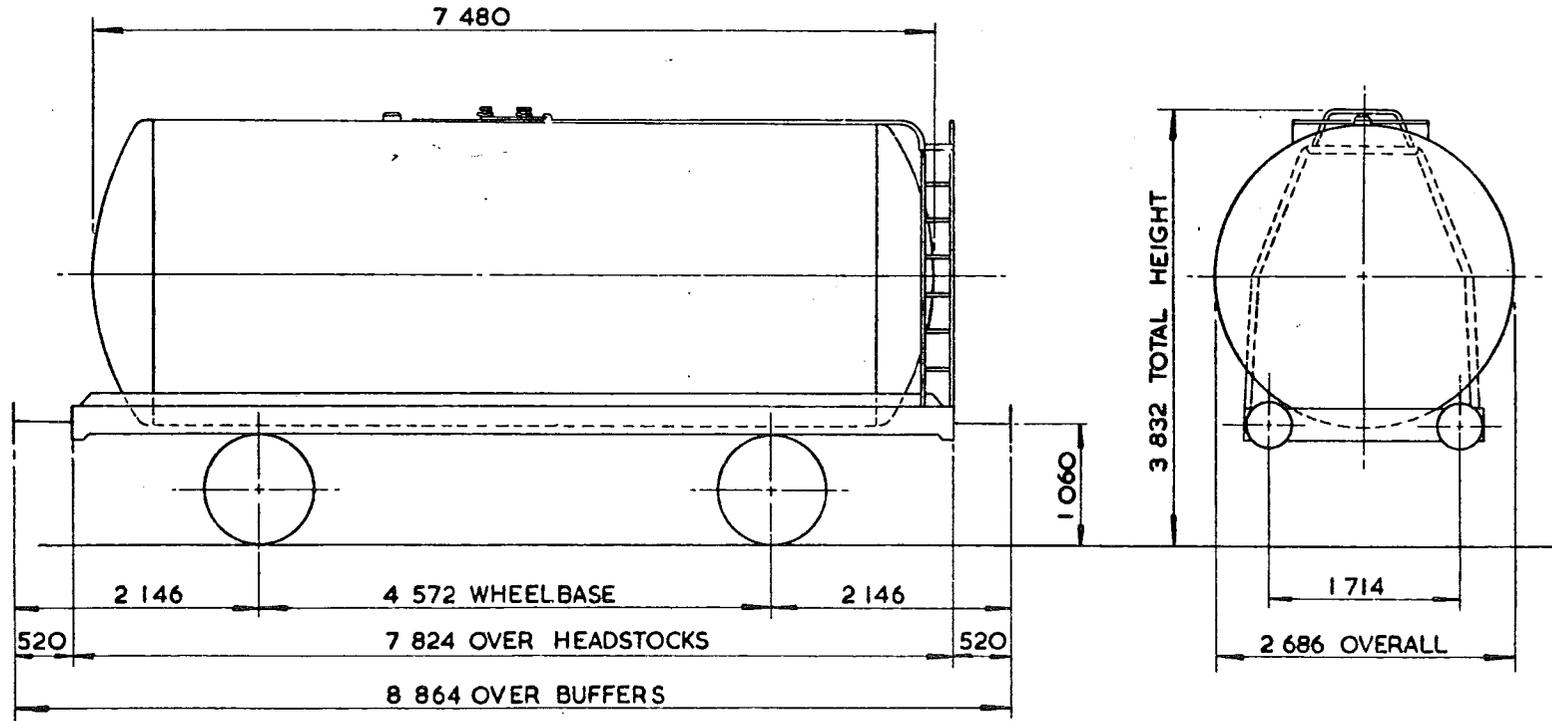

TARE -	13 050 kg
CARRYING CAPACITY -	32 900 kg
CAPACITY -	39 414 litres
MAX. SPEED -	60 mile/h
WHEELS -	952 DIA.
JOURNALS -	140 DIA. ROLLER BEARINGS

BUFFERS -	HYDRAULIC 406 DIA HEADS
COUPLINGS -	INSTANTER
MIN. CURVE -	31m
GEN. ARRGT. DRG. No. -	
BRAKE -	AIR BLOCK VACUUM PIPED HAND LEVER.
SUSPENSION -	DOUBLE LINK

BUILDER -	CHARLES ROBERTS
OWNER -	SUKO & B.P.O.
REGISTERED BY -	C.M. & E.E.(B.R.B.) DERBY
YEAR BUILT -	1966
REGISTRATION Nos. -	SUKO 65500 TO 65617 RANGE BPQ 60569 TO 60679 RANGE
OWNERS Nos. -	

ISSUE 2
EX.P.O. DIAGRAM 6/724 (ALLOCATED)

46 tonnes GLW. TANK WAGON - CLASS A

TTO26E

EXCESS LENGTH	4	H	M	L	E
tonnes	46	46	13	13	
VB	0	0	0	0	
AB	22	22	10	10	
RA	8	8	1	1	
MAX SPEED	60	60	45	45	

TOPS CODE										
CARKND			AARKND			OPERATING PANEL No				
T	T	B	T	T	B	A	1	4	5	5

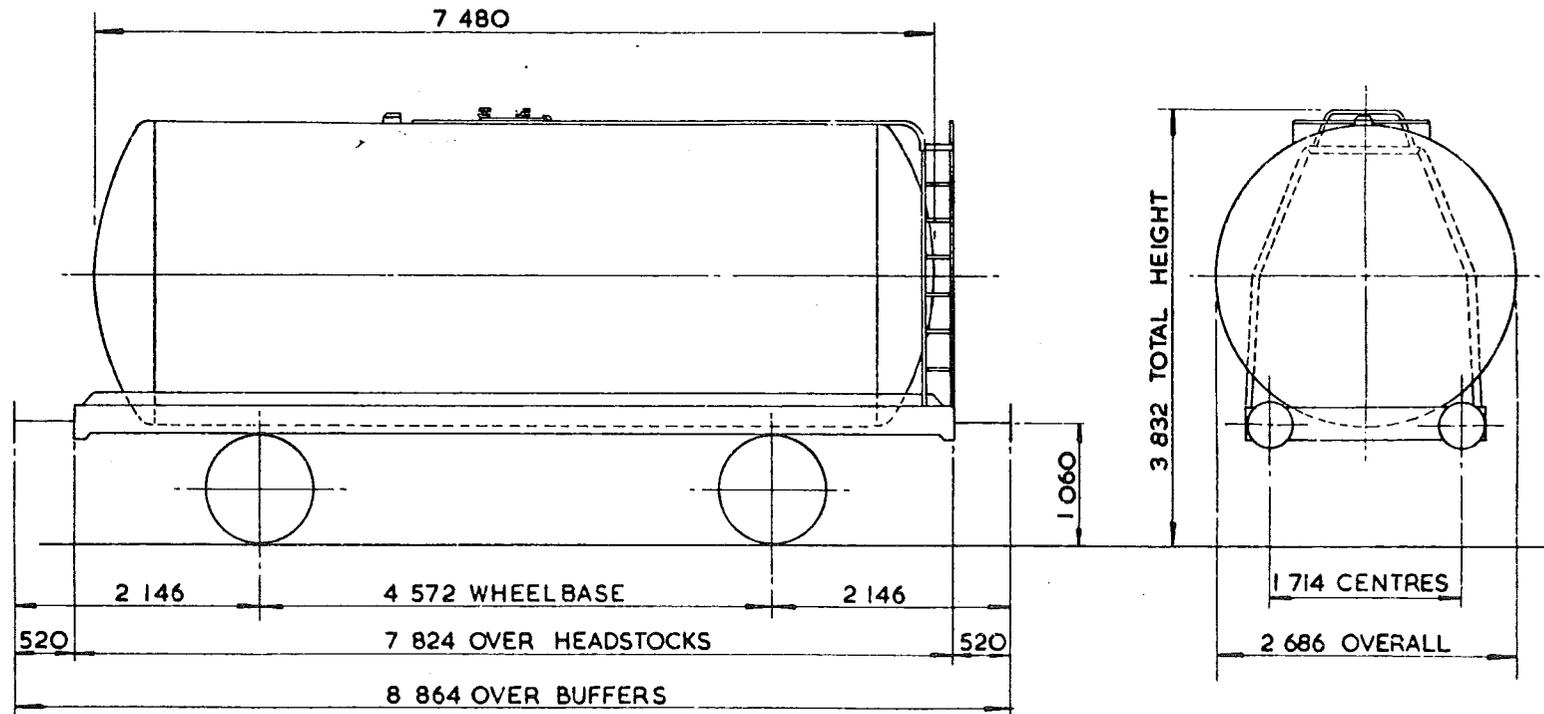

TARE -	13 000 kg
CARRYING CAPACITY -	33 000 kg
CAPACITY - PETROL	38 154 litres, KERO-GAS OIL 38 745 litres
MAX SPEED -	60 mile/h
WHEELS -	952 DIA.
JOURNALS -	140 DIA. ROLLER BEARINGS

BUFFERS -	HYDRAULIC 406 DIA. HEADS.
COUPLINGS -	INSTANTER
MIN. CURVE	31m
GEN. ARRGT. DRG. No	
BRAKE -	AIR BLOCK VACUUM PIPED & HAND LEVER
SUSPENSION -	DOUBLE LINK

BUILDER -	POWELL DUFFRYN
OWNER	SUKO & B.RO.
REGISTERED BY -	C.M. & E.E.(B.R.B) DERBY
YEAR BUILT -	1967
REGISTRATION Nos -	SUKO 60512 TO 67323 RANGE BPO 37188 TO 37195 RANGE
OWNERS Nos -	

ISSUE 2

EX. PO. DIAGRAM 6/715 (ALLOCATED).

46 tonnes G L W TANK WAGON - CLASS B

TTO26F

EXCESS LENGTH	4	H	M	L	E
tonnes	46	46	13	13	
VB	0	0	0	0	
AB	22	22	10	10	
RA	8	8	1	1	
MAX SPEED	60	60	45	45	

TOPS CODE										
CARKND		AARKND			OPERATING PANEL NO					
T	T	B	T	T	B	A	I	4	5	5

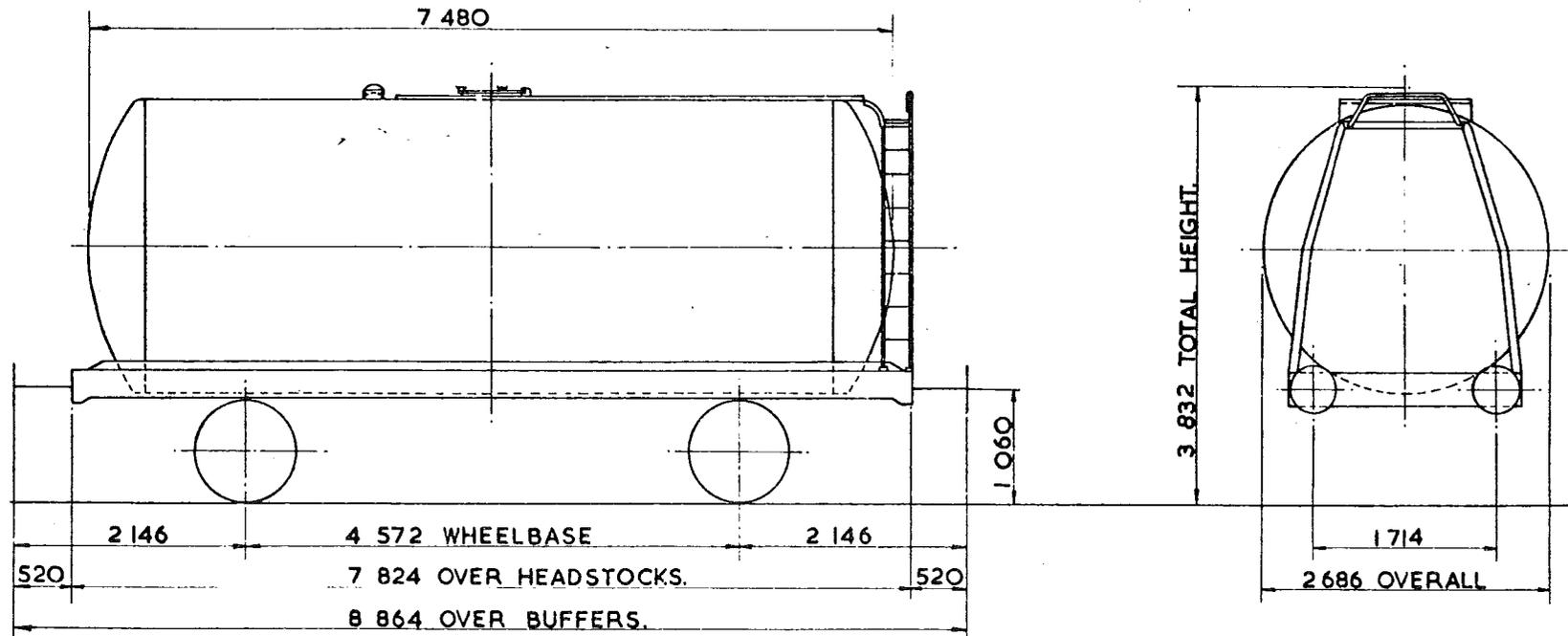

TARE -	13 000 kg
CARRYING CAPACITY -	33 000 kg
CAPACITY -	38 700 litres
MAX SPEED	60 mile/h.
WHEELS -	952 DIA.
JOURNALS -	140 DIA. ROLLER BEARINGS.

BUFFERS -	HYDRAULIC 406 DIA. HEADS.
COUPLER	INSTANTER
MIN CURVE	31m.
GEN ARREST DTG No -	
TRAFFIC -	AIR BLOCK, VACUUM PIPED & HAND LEVER
TRAILER -	DOUBLE LINK.

BUILDER -	POWELL DUFFRYN.
OWNER -	SUKO & B.P.O.
REGISTERED BY -	C.M. & E.E. (B.R.B.) DERBY.
YEAR BUILT -	1966
REGISTRATION Nos. -	SUKO 65618 TO 65711 RANGE BPO 65671 TO 65766 RANGE
OWNERS Nos. -	

ISSUE 2

EX. P.O. DIAGRAM. 6/725 (ALLOCATED)

46 tonnes G.L.W. TANK WAGON CLASS 'B'

TT O26 H

EXCESS LENGTH	4	H	M	L	E
tonnes	46	46	14	14	
VB	21	21	8	8	
AB					
RA	8	8	1	1	
MAX. SPEED	60	60	45	45	

TOPS CODE										
CARKND		AARKND			OPERATING PANEL No					
T	T	F	T	T	F	A	1	4	9	9

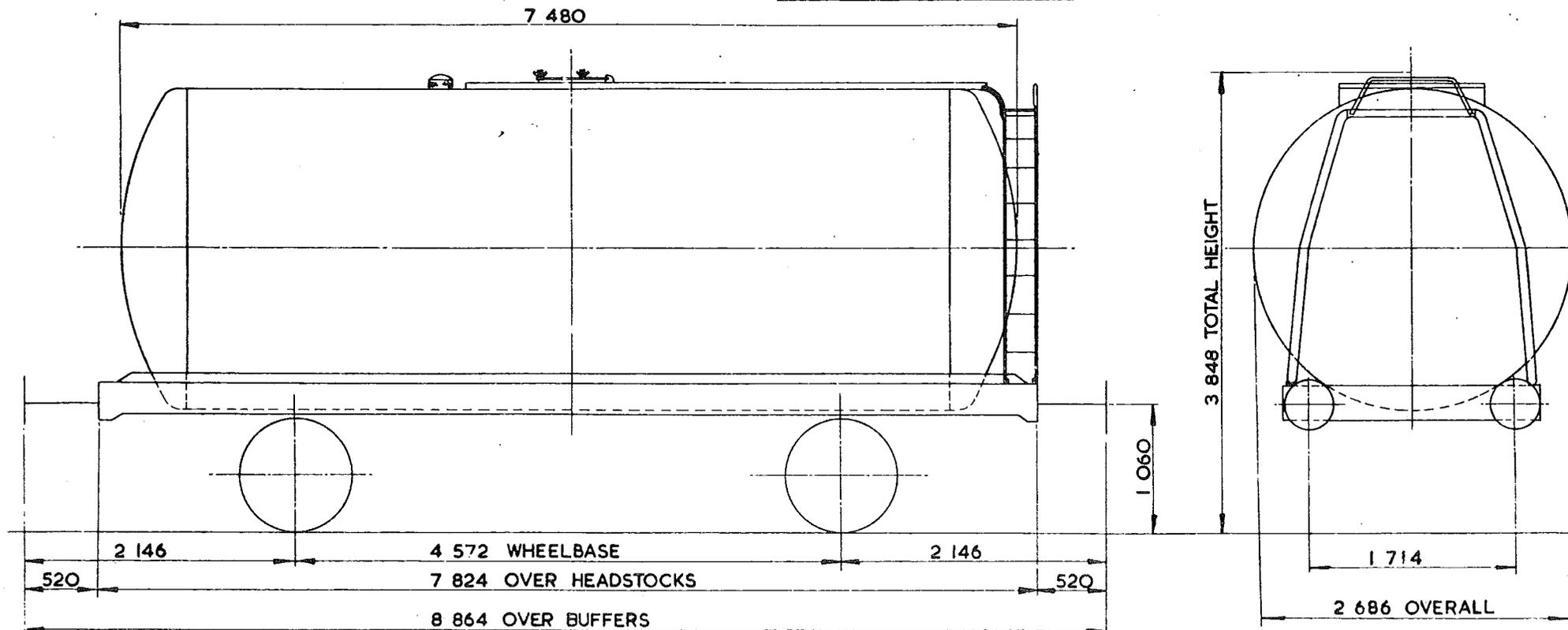

TARE - 13 ³⁰⁰ kg
CARRYING CAPACITY - 32 ⁷⁰⁰ kg
CAPACITY - 34840 litres BRITOL. 38636 litres KERO-GAS OIL
MAX. SPEED - 60 mile/h
WHEELS - 952 DIA
JOURNALS - 140 DIA ROLLER BEARINGS

BUFFERS - HYDRAULIC 406 DIA. HEADS.
COUPLINGS - INSTANTER
MIN. CURVE - 31 m
GEN. ARRGT. DRG. No. -
BRAKE - VACUUM BLOCK & HAND LEVER
SUSPENSION - DOUBLE LINK

BUILDER - R.Y. PICKERING.
OWNER - SUKO & B.P.O.
REGISTERED BY - C.M. & E.E.(B.R.B.) DERBY.
YEAR BUILT - 1965
REGISTRATION Nos. - SUKO 66118 TO 66222 RANGE BPO 66172 TO 66271 RANGE
OWNERS Nos. -

ISSUE 2
EX. P.O. DIAGRAM 6/171.

46 tonnes G.L.W. TANK WAGON - CLASS B

TTO26J

EXCESS LENGTH	4	H	M	L	E
tonnes	46	46	14	14	
VB	21	21	8	8	
AB					
RA	8	8	1	1	
MAX. SPEED	60	60	45	45	

TOPS CODE									
CARKND		AARKND		OPERATING PANEL No.					
T	T	F	T	F	A	1	4	9	9

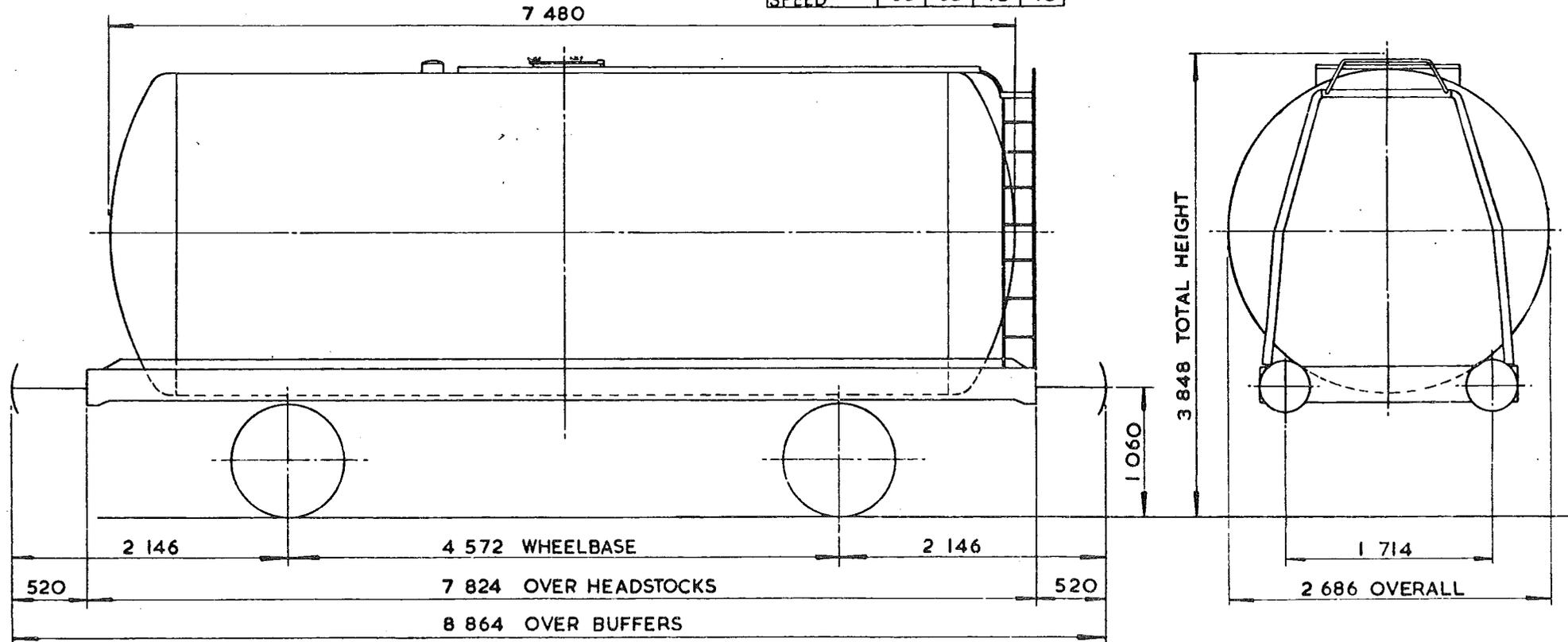

TARE - 13 300 kg
CARRYING CAPACITY - 32 700 kg
CAPACITY - 34804 litres - BUTANE 38636 litres - KERO- GAS OIL
MAX. SPEED - 60 mile/h
WHEELS - 952 DIA.
JOURNALS - 140 DIA. ROLLER BEARINGS

BUFFERS - HYDRAULIC 406 DIA. HEADS.
COUPLINGS - INSTANTER
MIN. CURVE - 31 m
GEN. ARRGT. DRG. No. -
BRAKE - VACUUM BLOCK & HAND LEVER
SUSPENSION - DOUBLE LINK

BUILDER - R.Y. PICKERING
OWNER - SUKO & B.P.O.
REGISTERED BY - C.M. & E.E. (B.R.B.) DERBY
YEAR BUILT - 1965
REGISTRATION Nos. - SUKO 66223 TO 66318 RANGE BPO 66272 TO 66367 RANGE
OWNERS Nos. -

ISSUE 2

EX PO. DIAGRAM 6/174

46 tonnes G. L. W. TANK WAGON - CLASS A

TTO26K

EXCESS LENGTH	4	H	M	L	E
tonnes	46	46	13	13	
VB	0	0	0	0	
AB	21	21	7	7	
RA	8	8	1	1	
MAX. SPEED	60	60	45	45	

TOPS CODE						
CARKND		AARKND		OPERATING PANEL No		
T	T	B	T	B	A	1567

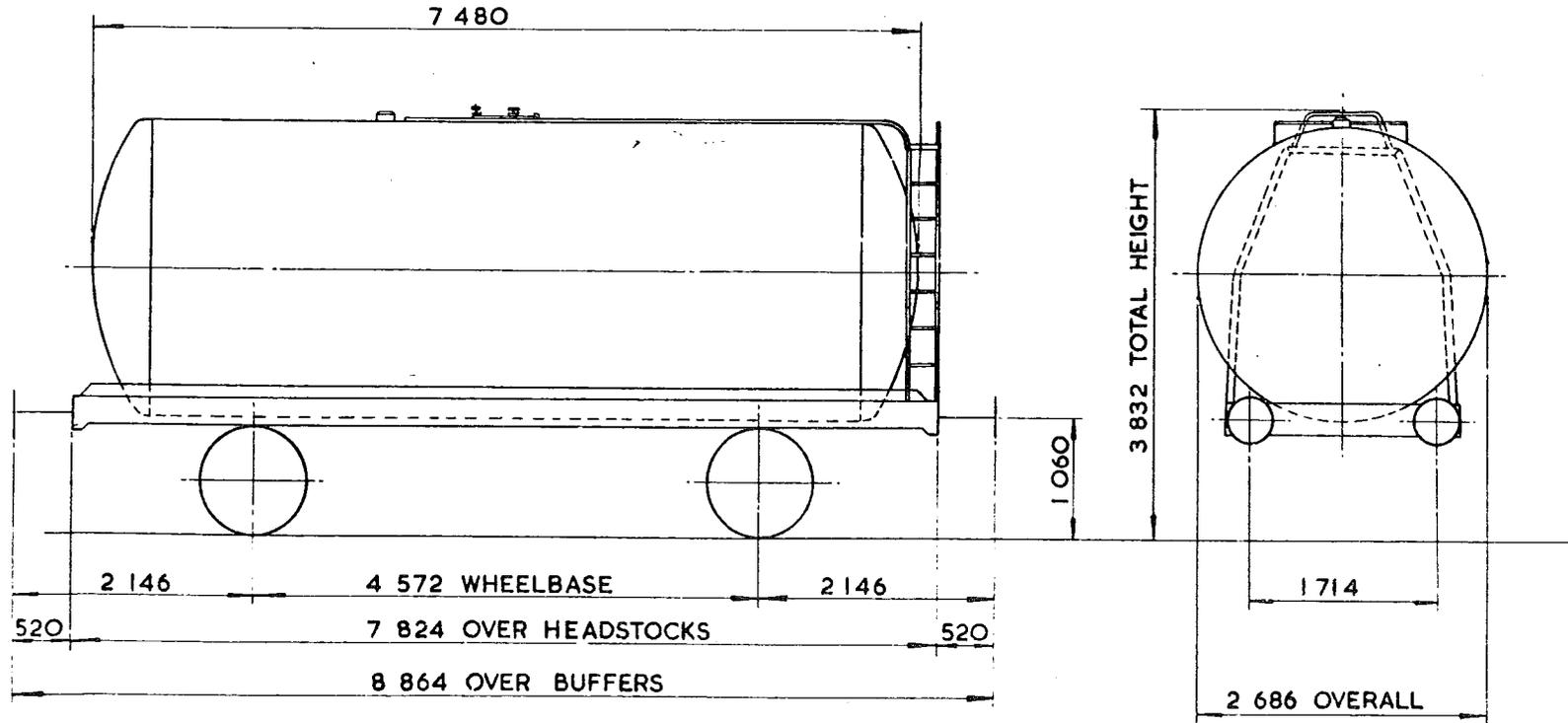

TARE - 13 150 kg
CARRYING CAPACITY - 32800 kg
CAPACITY - PETROL 38154 litres, KERO-GAS OIL 38745 litres
MAX. SPEED - 60 mile/h
WHEELS - 952 DIA.
JOURNALS - 140 DIA. ROLLER BEARINGS

BUFFERS - HYDRAULIC 406 DIA. HEADS.
COUPLINGS - INSTANTER
MIN. CURVE - 31m
GEN. ARRGT. DRG. No. -
BRAKE - AIR BLOCK, VACUUM PIPED & HAND LEVER.
SUSPENSION - DOUBLE LINK

BUILDER - R.Y. PICKERING
OWNER - SUKO & B.P.O.
REGISTERED BY - C.M. & E.E. (B.R.B) DERBY
YEAR BUILT - 1966/67
REGISTRATION Nos - SUKO 67000 TO 67931 RANGE BPO 67060 TO 67974 RANGE
OWNERS Nos. -

ISSUE 2

EX P.O. DIAGRAM 6/161

46 tonnes GL.W. TANK WAGON - CLASS A

TTO26 L

EXCESS LENGTH	4	H	M	L	E
tonnes	46	46	14	14	
VB	21	21	8	8	
AB					
RA	8	8	1	1	
MAX SPEED	60	60	45	45	

TOPS CODE									
CARKND		AARKND			OPERATING PANEL No				
T	T	F	T	F	A	1	4	9	9

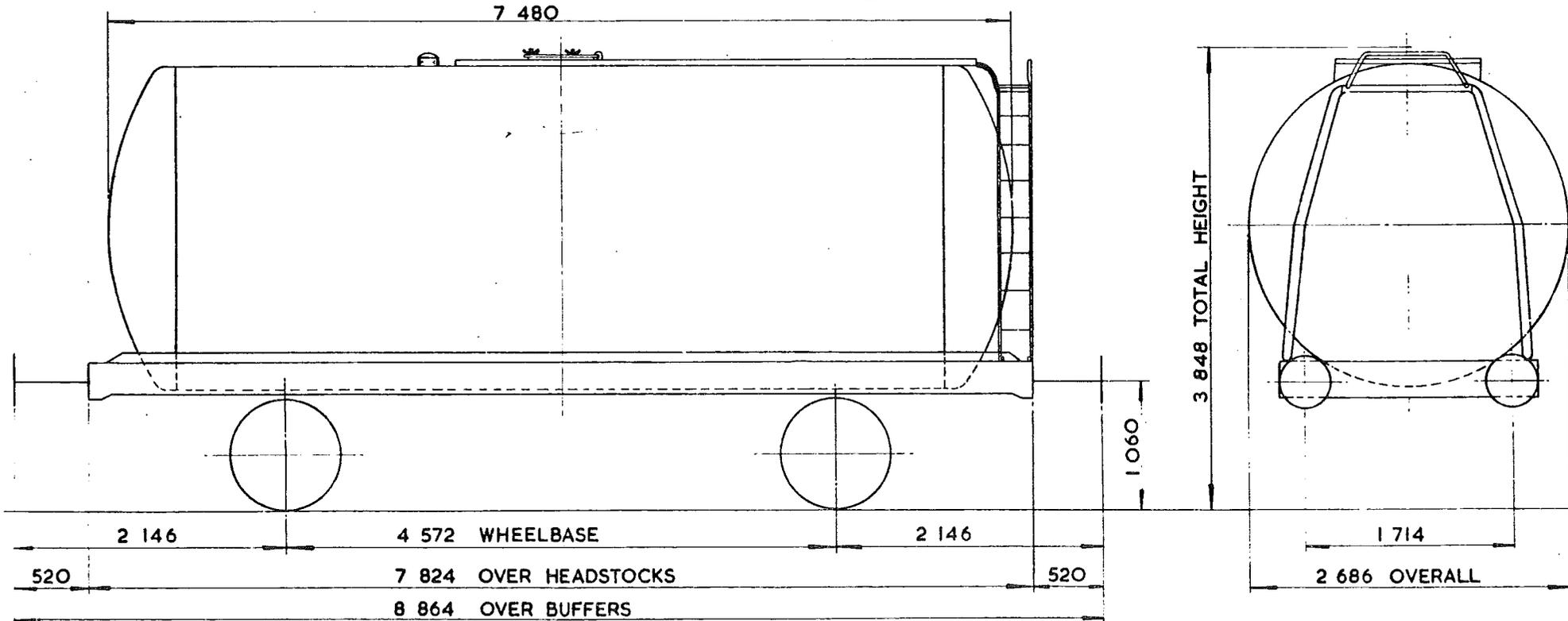

TARE -	13 650 kg
CARRYING CAPACITY -	32 300 kg
CAPACITY -	39 436 litres.
MAX. SPEED -	60 mile/h
WHEELS -	952 DIA.
JOURNALS -	140 DIA. ROLLER BEARINGS

BUFFERS -	HYDRAULIC 406 DIA. HEADS
COUPLINGS -	INSTANTER
MIN. CURVE -	31 m
GEN. ARRGT. DRG No. -	
BRAKE -	VACUUM BLOCK & HAND LEVER
SUSPENSION -	DOUBLE LINK

BUILDER -	POWELL DUFFRYN
OWNER -	SUKO & BPO
REGISTERED BY -	C.M. & E.E. (B.R.B.) DERBY
YEAR BUILT -	1964
REGISTRATION Nos. -	SUKO 60100 TO 68204 (RANGE) BPC 60160 TO 68274 (RANGE)
OWNERS Nos. -	

ISSUE 2

EX. P. O. DIAGRAM 6/716 (ALLOCATED)

46 tonnes G. L. W. TANK WAGON - CLASS A

TTO26 M

EXCESS LENGTH	4	H	M	L	E
tonnes	46	46	14	14	
	VB	21	21	8	8
	AB				
	RA	8	8	1	1
MAX. SPEED	60	60	45	45	

TOPS CODE										
CARKND			AARKND			OPERATING PANEL No.				
T	T	F	T	T	F	A	1	4	9	9

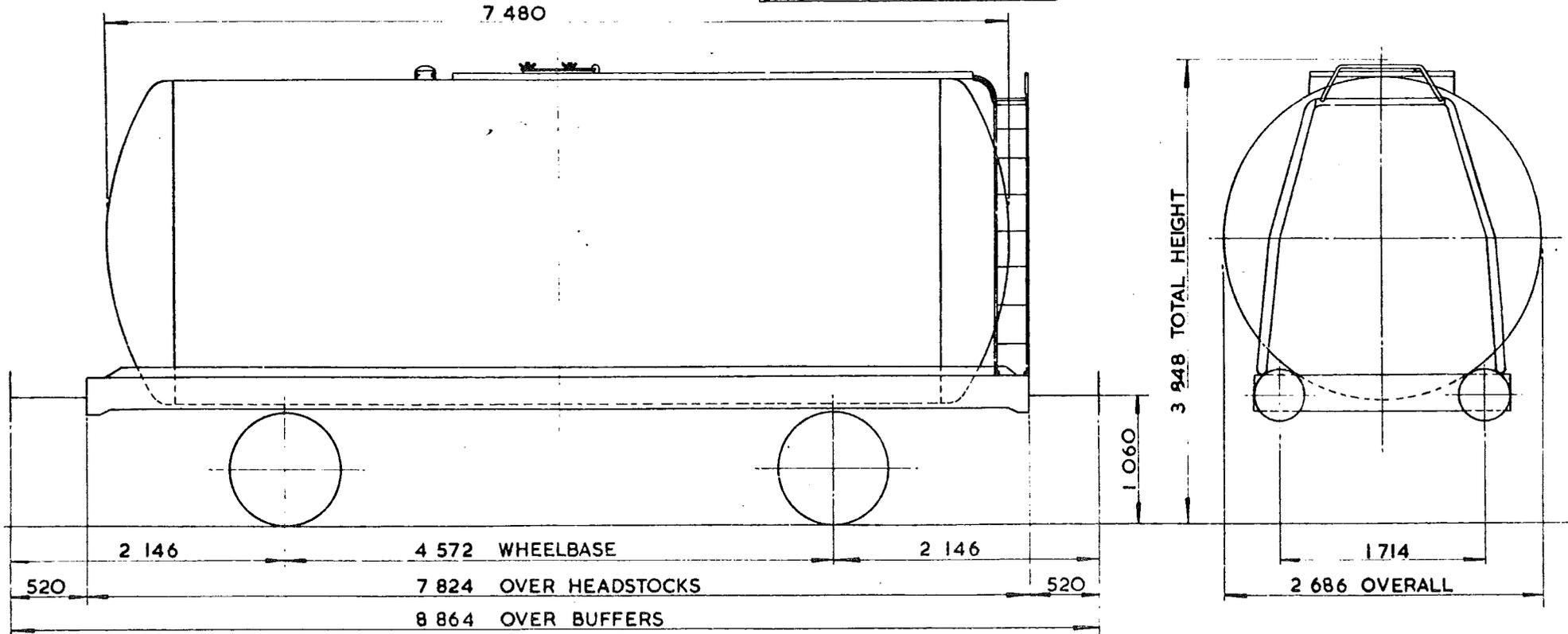

TARE -	13 200 kg
CARRYING CAPACITY -	32 800 kg
CAPACITY -	37 881 litres - PETROL, 38 468 litres - KERO-GAS OIL
MAX. SPEED -	60 mile/h
WHEELS -	952 DIA.
JOURNALS -	140 DIA. ROLLER BEARINGS

BUFFERS -	HYDRAULIC .406 DIA. HEADS.
COUPLINGS -	INSTANTER
MIN. CURVE -	31 m
GEN. ARRGT. DRG. No. -	
BRAKE -	VACUUM BLOCK & HAND LEVER
SUSPENSION -	DOUBLE LINK

BUILDER -	R.Y. PICKERING
OWNER -	SUKO & B.P.O.
REGISTERED BY -	C.M. & E.E. (B.R.B.) DERBY
YEAR BUILT -	1964
REGISTRATION Nos. -	SUKO 60159 TO 68214 RANGE BPO 60170 TO 68280 RANGE
OWNERS Nos. -	

ISSUE 2
EX PO. DIAGRAM 6/159

46 tonnes G.L.W. TANK WAGON - CLASS A

TTO26N

EXCESS LENGTH	4	H	M	L	E
tonnes	46	46	14	14	
VB	21	21	8	8	
AB					
RA	8	8	1	1	
MAX. SPEED	60	60	45	45	

TOPS CODE										
CARKND			AARKND			OPERATING PANEL No.				
T	T	F	T	T	F	A	1	4	9	9

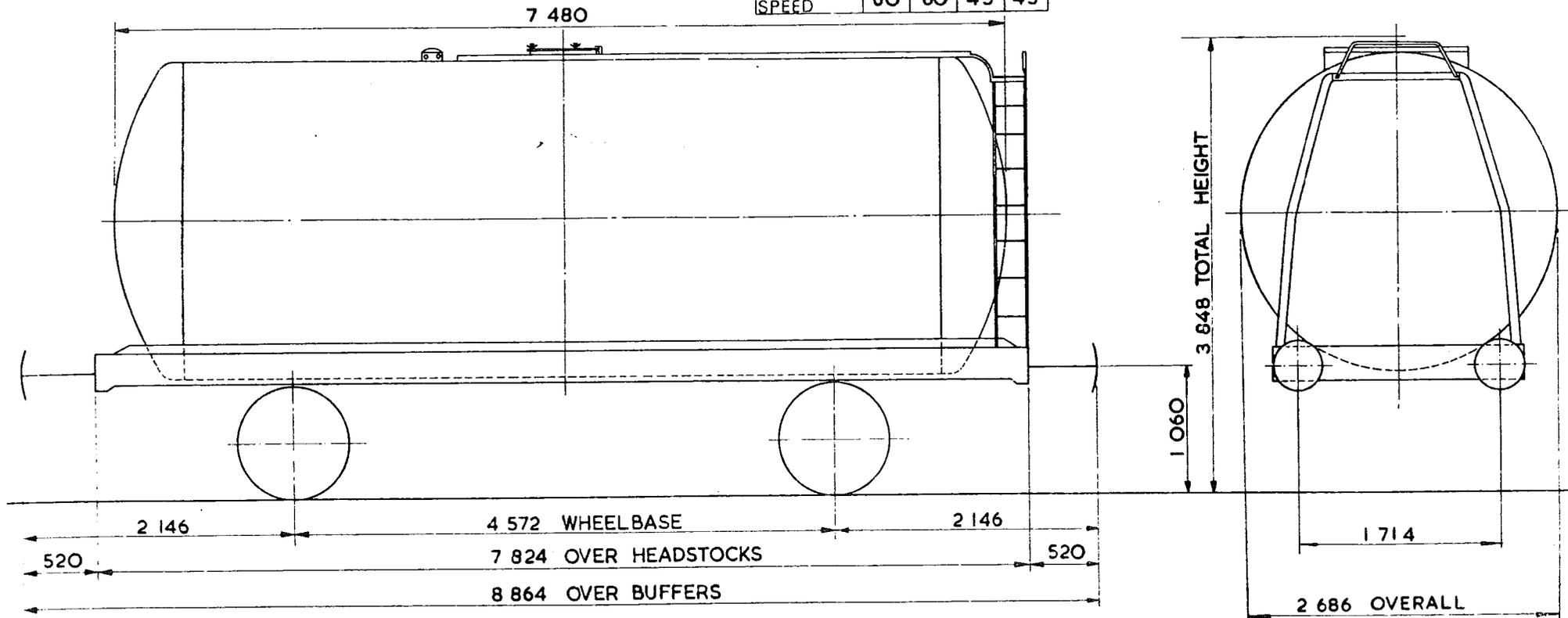

TARE - 13 300 kg
CARRYING CAPACITY - 32 700 kg
CAPACITY - 37 854 litres - PETROL 38 440 litres KERO-GAS OIL
MAX. SPEED - 60 mile/h
WHEELS - 952 DIA.
JOURNALS - 140 DIA. ROLLER BEARINGS

BUFFERS - HYDRAULIC 406 DIA. HEADS.
COUPLINGS - INSTANTER
MIN. CURVE 31m
GEN. ARRGT DRG. No. -
BRAKE - VACUUM BLOCK & HAND LEVER
SUSPENSION - DOUBLE LINK

BUILDER - R.Y. PICKERING
OWNER - SUKO & BPO
REGISTERED BY - C.M. & E.E. (B.R.B.) DERBY
YEAR BUILT - 1965
REGISTRATION Nos - SUKO 60103 TO 68548 (RANGE) BPO 60161 TO 68589 (RANGE)
OWNERS Nos. -

ISSUE 2

EX. PO. DIAGRAM 6/160

46 tonnes G.L.W. TANK WAGON

TTO26P

EXCESS LENGTH	4	H	M	L	E
TONS	46	46	14	14	
VB	21	21	8	8	
AB					
RA	8	8	1	1	
MAX. SPEED	60	60	45	45	

TOPS CODE									
CARKND			AARKND			OPERATING PANEL No			
T	T	T	F	T	T	F	A	I	500

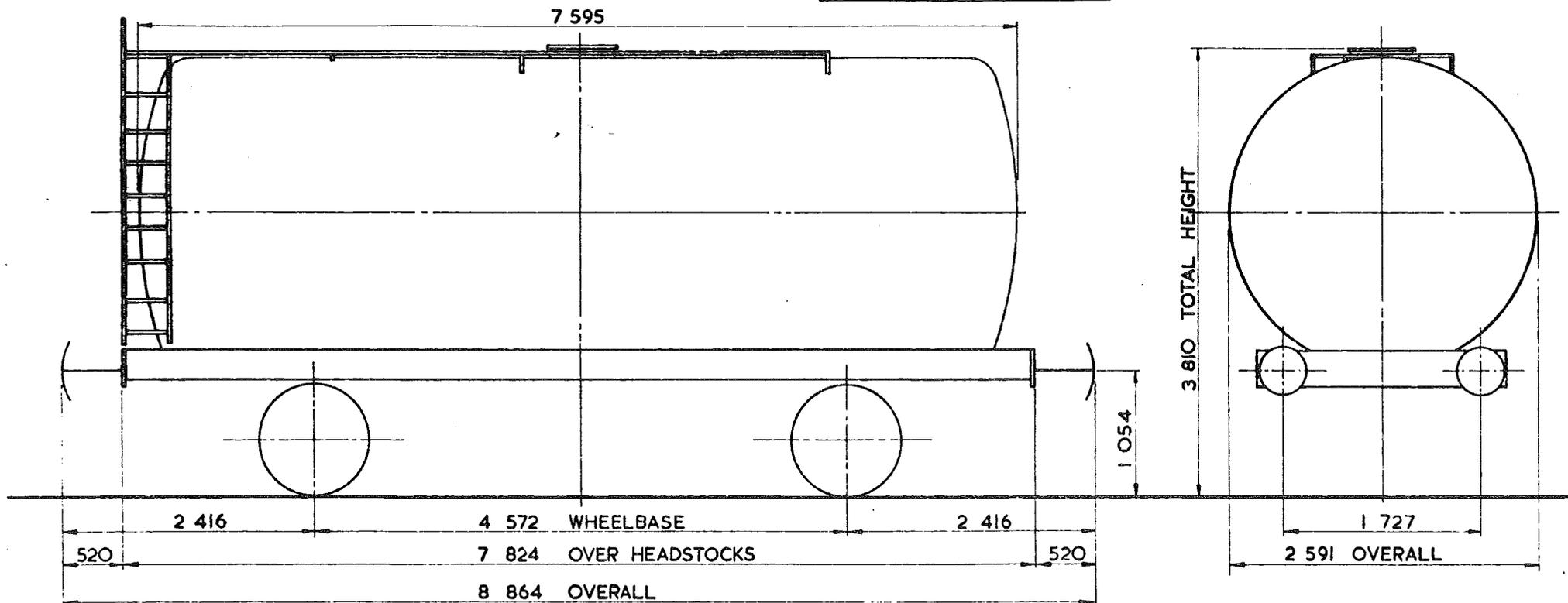

TARE -	13450kg
CARRYING CAPACITY -	32500kg
CAPACITY -	39532 litres
MAX. SPEED -	60mile/h
WHEELS -	952 DIA.
JOURNALS -	140 DIA. ROLLER BEARING

BUFFERS -	HYDRAULIC 406 DIA. HEADS
COUPLINGS -	INSTANTER
MIN. CURVE -	31m
GEN. ARRGT. DRG. No. -	
BRAKE -	VACUUM BLOCK & HAND LEVER
SUSPENSION -	DOUBLE LINK

ISSUE 2
EX. PO. DIAGRAM 6/718(ALLOCATED)

46 tonnes G.L.W. TANK WAGON

TTO26 Q

EXCESS LENGTH	4	H	M	L	E
tonnes	46	46	13	13	
VB	0	0	0	0	
AB	22	22	10	10	
RA	8	8	1	1	
MAX. SPEED	60	60	45	45	

TOPS CODE		
CARKND	AARKND	OPERATING PANEL No
T T B	T T B A	1 5 1 6

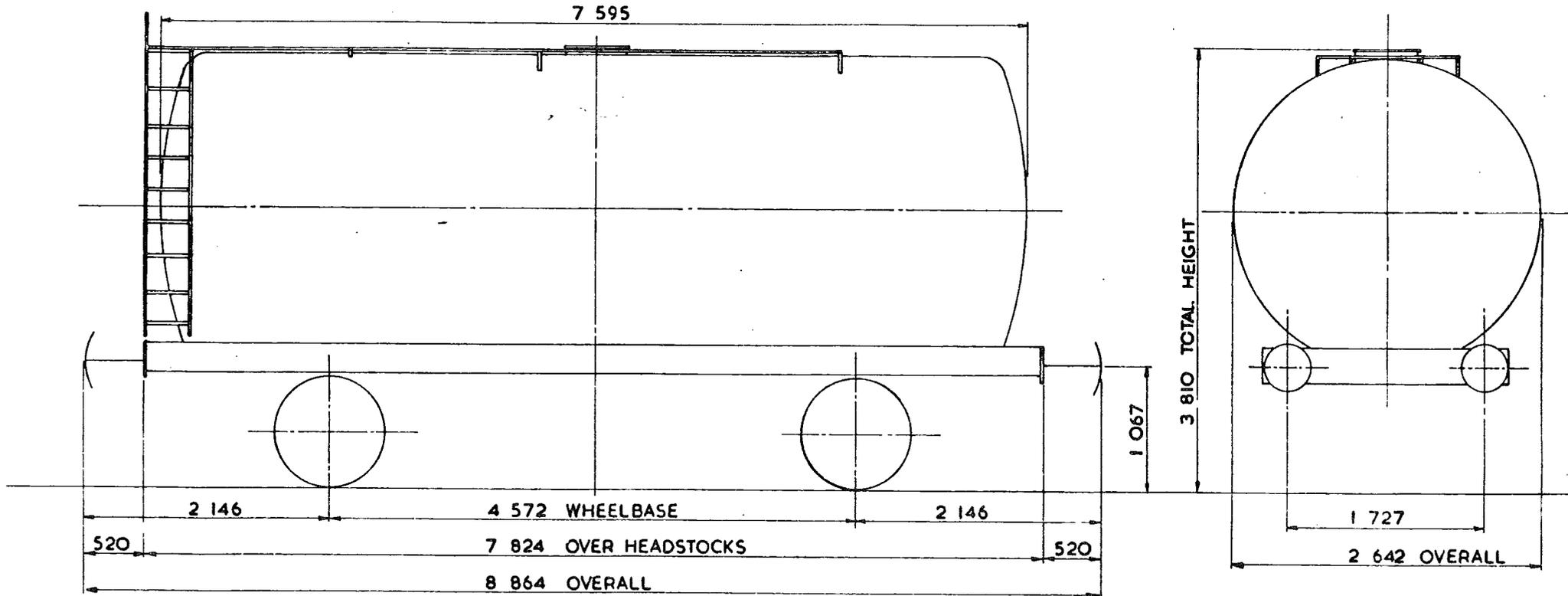

TARE -	12 900 kg
CARRYING CAPACITY -	33 100 kg
CAPACITY -	39 232 litres
MAX. SPEED -	60 mile/h
WHEELS -	952 DIA.
JOURNALS -	140 DIA ROLLER BEARINGS

BUFFERS -	HYDRAULIC 406 DIA. HEADS
COUPLINGS -	INSTANTER
MIN. CURVE -	31m
GEN. ARRGT. DRG. No. -	
BRAKE -	AIR BLOCK, VACUUM PIPED & HAND LEVER
SUSPENSION -	DOUBLE LINK

ISSUE 2

EX. P.O. DIAGRAM 6/719 (ALLOCATED)

46 tonnes G.L.W. TANK WAGON

TTO26R

EXCESS TONNAGE	4	H	M	L	E
tonnes	46	46	13	13	
VB	0	0	0	0	
BR	22	22	10	10	
PA	8	8	1	1	
MAX SPEED	60	60	45	45	

TOPS CODE		
CARKND	AARKND	OPERATING PANEL
T T	B T T B A I	5 0 6

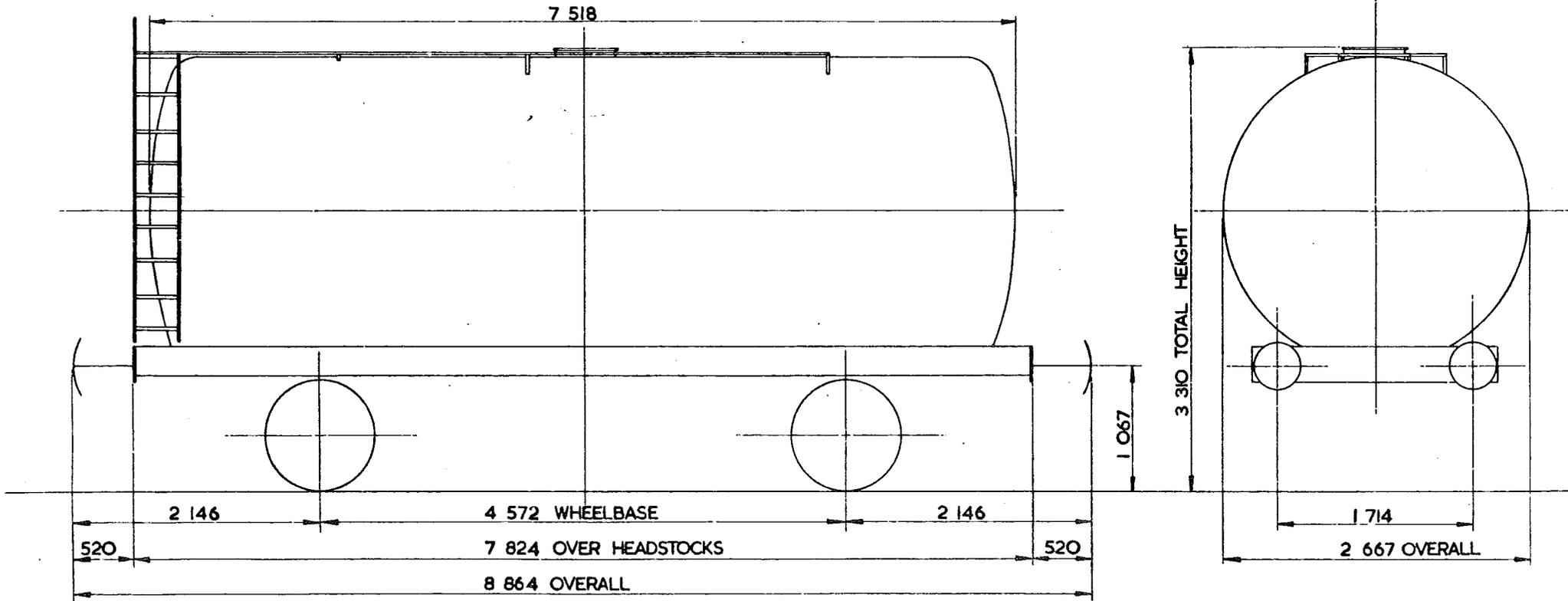

TARE -	12 650 kg
CARRYING CAPACITY -	33 300 kg
CAPACITY -	40 000 litres
MAX SPEED -	60 mile/h
WHEELS -	952 DIA
JOURNALS -	140 DIA ROLLER BEARINGS

BUFFERS -	HYDRAULIC 406 DIA. HEADS.
COUPLINGS	INSTANTER
MIN CURVE	31 m
GEN. ARRGT	
BRAKE -	AIR BLOCK/VACUUM PIPED & HAND LEVER.
SUSPENSION -	DOUBLE LINK

BUILDER -	POWELL DUFFRYN
OWNER -	SUKO & BPO
REGISTERED BY	C.M. & E.E. (B.R.B.) DERBY
YEAR BUILT	1966
REGISTRATION Nos.	SUKO 67346 TO 67400 BPO 67389 TO 674399
WORKING Nos.	

ISSUE 2

EX. PO. DIAGRAM 6/720. (ALLOCATED).

46 tonnes G.L.W. TANK WAGON CLASS 'A'

TT026X

EXCESS LENGTH	4	H	M	L	E
tonnes	46	46	13	13	
VB					
AB	21	21	7	7	
BA	8	8	1	1	
MAX SPEED	60	60	60	60	

TOPS CODE	
CARKND	AARKND
T T A T T A A 1 6 1 5	

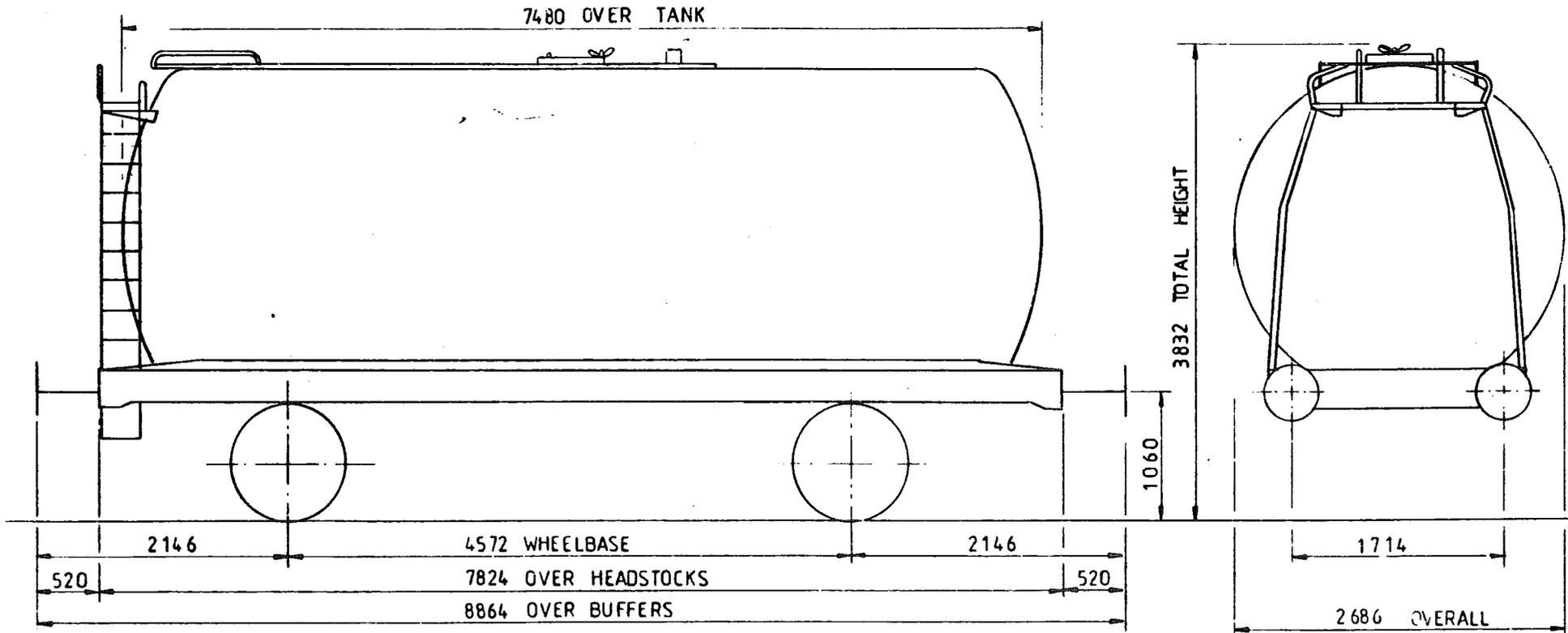

TARE	12 000 kg
CARRYING CAPACITY	33 000 kg
CAPACITY	38154 litres (Petrol), 38745 litres (Kero-gas oil)
MAX SPEED	60 mile/h
WHEELS	φ 952
JOURNALS	φ140 ROLLER BEARINGS

BUFFERS	HYDRAULIC φ406 HEADS
COUPLINGS	INSTANTER
MIN CURVE	31 m
GEN ARRGT DRG No	
BRAKE	AIR BLOCK
	HAND LEVER
SUSPENSION	FRICTION CONTROLLED PARABOLIC SPRING

ISSUE 1

EX PO DIAGRAM 6/161(ALLOCATED)

46 tonnes GL.W. TANK WAGON-CLASS A

TT 026 V

EXCESS LENGTH	4	H	M	L	E
tonnes	46	46	14	14	
VB					
AB	26	26	11	11	
RA	8	8	1	1	
MAX SPEED	60	60	60	60	

TOPS CODE										
CARKND			AARKND			OPERATING PANEL No.				
T	T	A	T	T	A	A	1	4	6	4

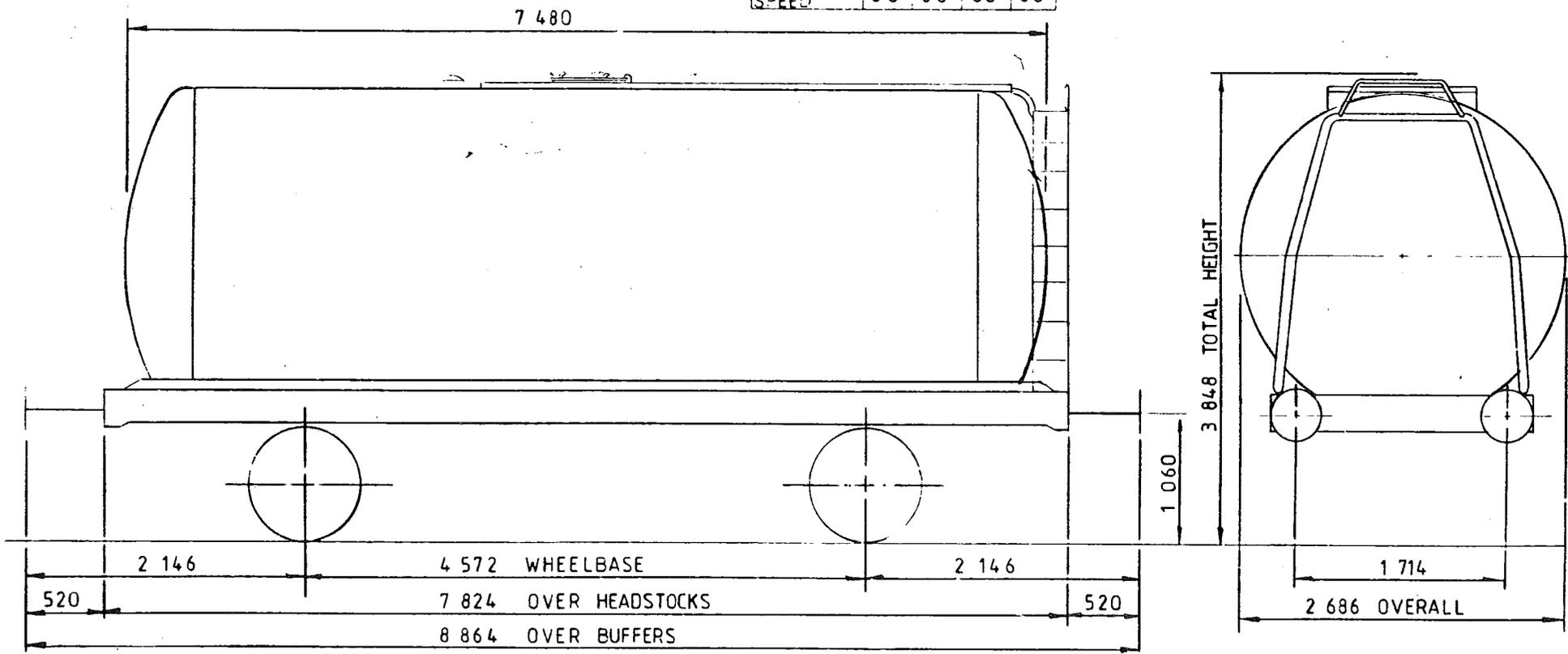

TARE	13 300 kg
CARRYING CAPACITY	32 700 kg
CAPACITY	37854 litres PETROL, 38440 litres KERO-GAS OIL
MAX SPEED	60 mile / h
WHEELS	952 DIA.
JOURNALS	140 DIA. ROLLER BEARINGS

BUFFER	HYDRAULIC, 406 DIA. HEADS
COUPLINGS	INSTANTER
MIN. CURVE	31 m
GEN. ARRGT. DRG. No.	
BRAKE	AIR BLOCK & HAND LEVER
SUSPENSION	FAT. 26

issue 1

EX PO DIAGRAM 6/160 (ALLOCATED)

46 tonne GLW TANK WAGON-CLASS 'A'

LOT NUMBER	

TOPS INFORMATION						
AARKND	OPERATING	OPERATING SPEED		BRAKE FORCE DATA		EXCESS LENGTH
CARKND	PANEL No.	60 mile/h UP TO	46 tonne GLW	7t FORCE UP TO	24.5 tonne GLW	RA (GLW)
T T A A		mile/h ABOVE		21t FORCE ABOVE		DESIGN SHEET
						W895

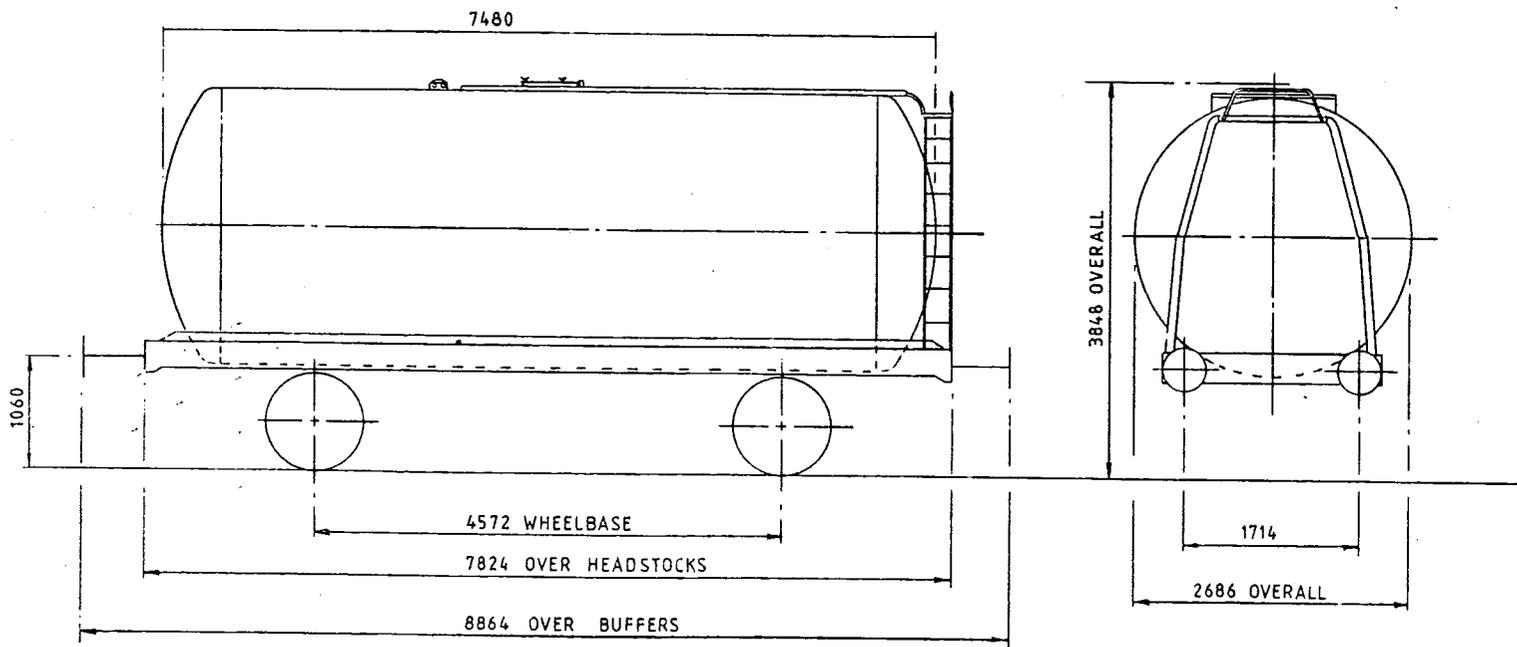

TARE-	12.800 Kg
CAPACITY, WEIGHT-	33.200 Kg
CAPACITY, VOLUME-	37.854 litres petrol, 38.440 litres kero gas oil
MIN. CURVE-	31m
GEN. ARRGT. DRG. NO.-	

BRAKE-	AIR BLOCK & HAND LEVER
SUSPENSION-	DOUBLE LINK & PARABOLIC SPRING
COUPLINGS-	INSTANTER
BUFFERS-	HYDRAULIC 406 DIA HEADS
WHEELS-	952 DIA
JOURNALS-	140 DIA ROLLER BEARINGS

ISSUE 1

46 tonnes G.L.W. TANK WAGON.

TTO27A

EXCESS LENGTH	4	H	M	L	E
tonnes	46	46	14	14	
VB	19	19	8	8	
AB					
RA	8	8	1	1	
MAX. SPEED	60	60	45	45	

TOPS CODE					
CARKND	ΛARKND	OPERATING PANEL No.			
T	T	F	T	F	A I S O I

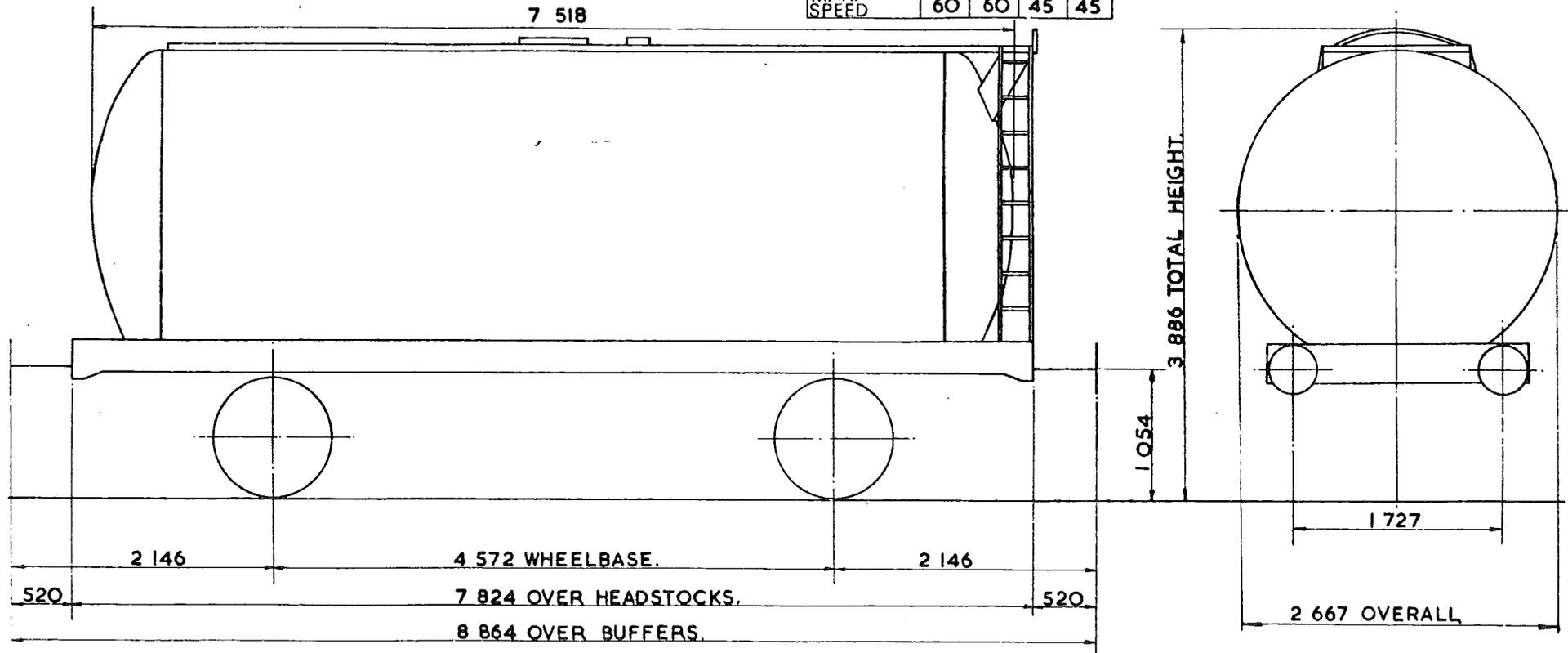

TARE - 13 400 kg
CARRYING CAPACITY - 32 600 kg
CAPACITY - 38 641 litres.
MAX. SPEED - 60 mile/h.
WHEELS - 952 DIA.
JOURNALS - 140 DIA. ROLLER BEARINGS.

BUFFERS - HYDRAULIC 406 DIA. HEADS
COUPLINGS - INSTANTER
MIN. CURVE - 31m.
GEN. ARRGT. DRG. No. -
BRAKE - VACUUM BLOCK & HAND LEVER
SUSPENSION - DOUBLE LINK.

BUILDER - CHARLES ROBERTS.
OWNER - CHARRINGTON GARDENER LOCKET.
REGISTERED BY - C.M.&E.E.(B.R.B.) DERBY.
YEAR BUILT - 1965.
REGISTRATION Nos. - 53731 TO 53735
OWNERS Nos. - 431 TO 435

ISSUE 2
EX. PO. DIAGRAM 6/796 (ALLOCATED)

46 tonnes G.L.W. TANK WAGON

TTO27B

EXCESS LENGTH	4	H	M	L	E
tonnes	46	46	14	14	
VB	19	19	8	8	
AB					
RA	8	8	1	1	
MAX. SPEED	60	60	45	45	

TOPS CODE										
CARKND		AARKND			OPERATING PANEL No					
T	T	F	T	T	F	A	I	5	O	I

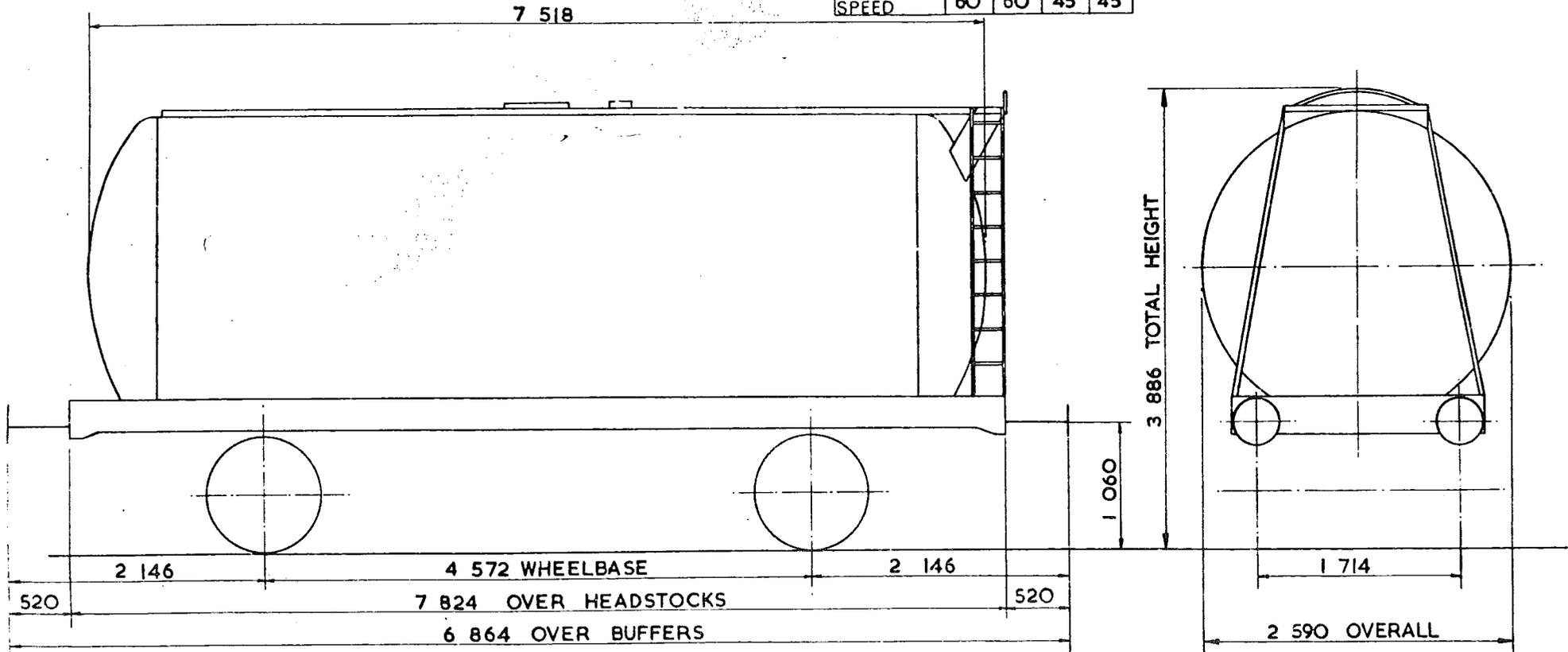

TARE - 14 100 kg
CARRYING CAPACITY - 31 900 kg
CAPACITY - 38 641 litres
MAX. SPEED - 60 mile/h
WHEELS - 952 DIA.
JOURNALS - 140 DIA. ROLLER BEARINGS.

BUFFERS - HYDRAULIC 406 DIA. HEADS
COUPLINGS - INSTANTER.
MIN. CURVE - 31m
GEN. ARRGT. DRG. No. -
BRAKE - VACUUM BLOCK & HAND LEVER
SUSPENSION - DOUBLE LINK.

BUILDER - R.Y. PICKERING.
OWNER - CHARRINGTON GARDNER LOCKET.
REGISTERED BY - C.M. & E.E. (B.R.B.) DERBY
YEAR BUILT - 1965/66.
REGISTRATION Nos. - 53741 TO 53761.
OWNERS Nos. - 441 TO 461

46 tonnes G.L.W. TANK WAGON

TTO27C

EXCESS LENGTH	4	H	M	L	E
tonnes	46	46	13	13	
VB	19	19	8	8	
AB					
RA	8	8	1	1	
MAX SPEED	60	60	45	45	

TOPS CODE										
CARKND			AARKND			OPERATING PANEL No				
T	T	F	T	T	F	A	1	5	1	9

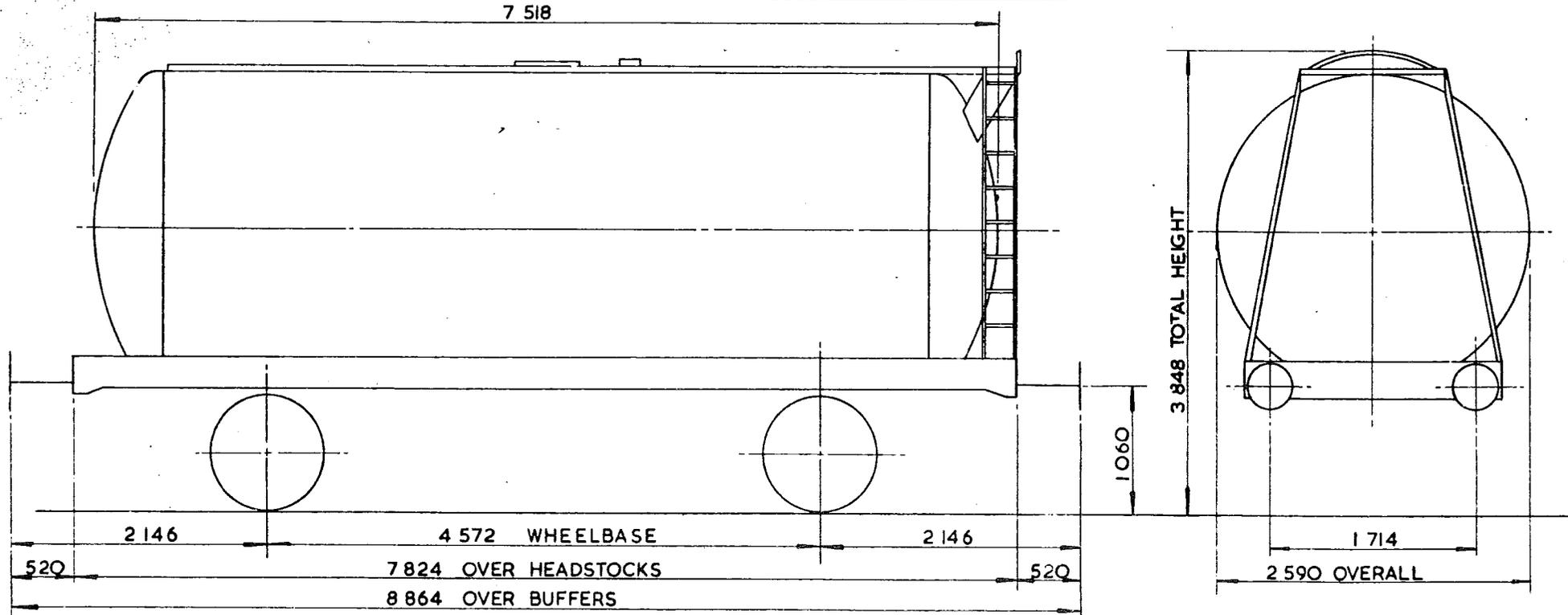

TARE -	13100kg
CARRYING CAPACITY	32 900 kg
CAPACITY	38185 litres
MAX. SPEED -	60 mile/h
WHEELS -	952 DIA
JOURNALS -	140 DIA ROLLER BEARINGS

BUFFERS -	HYDRAULIC. 406 DIA. HEADS.
COUPLINGS -	INSTANTER
MIN. CURVE -	31m
GEN. ARRGT. DRG. No -	
BRAKE -	VACUUM BLOCK & HAND LEVER
SUSPENSION -	DOUBLE LINK

BUILDER -	R. Y. PICKERING
OWNER -	CHARRINGTON GARDNER LOCKET
REGISTERED BY -	C.M. & E.E. (B.A.B.) DERBY
YEAR BUILT -	1965/66
REGISTRATION Nos. -	53771 TO 53778
OWNERS Nos. -	501 TO 508

ISSUE 2
EX. PO. DIAGRAM 6/793 (ALLOCATED)

46 tonnes G.L.W. TANK WAGON - CLASS B

TTO27D

EXCESS LENGTH	5	H	M	L	E
tonnes	46	46	15	15	
VB	19	19	8	8	
AB					
RA	8	8	1	1	
MAX. SPEED	60	60	45	45	

TOPS CODE									
CARKND			AARKND			OPERATING PANEL No			
T	T	F	T	F	A	1	5	2	1

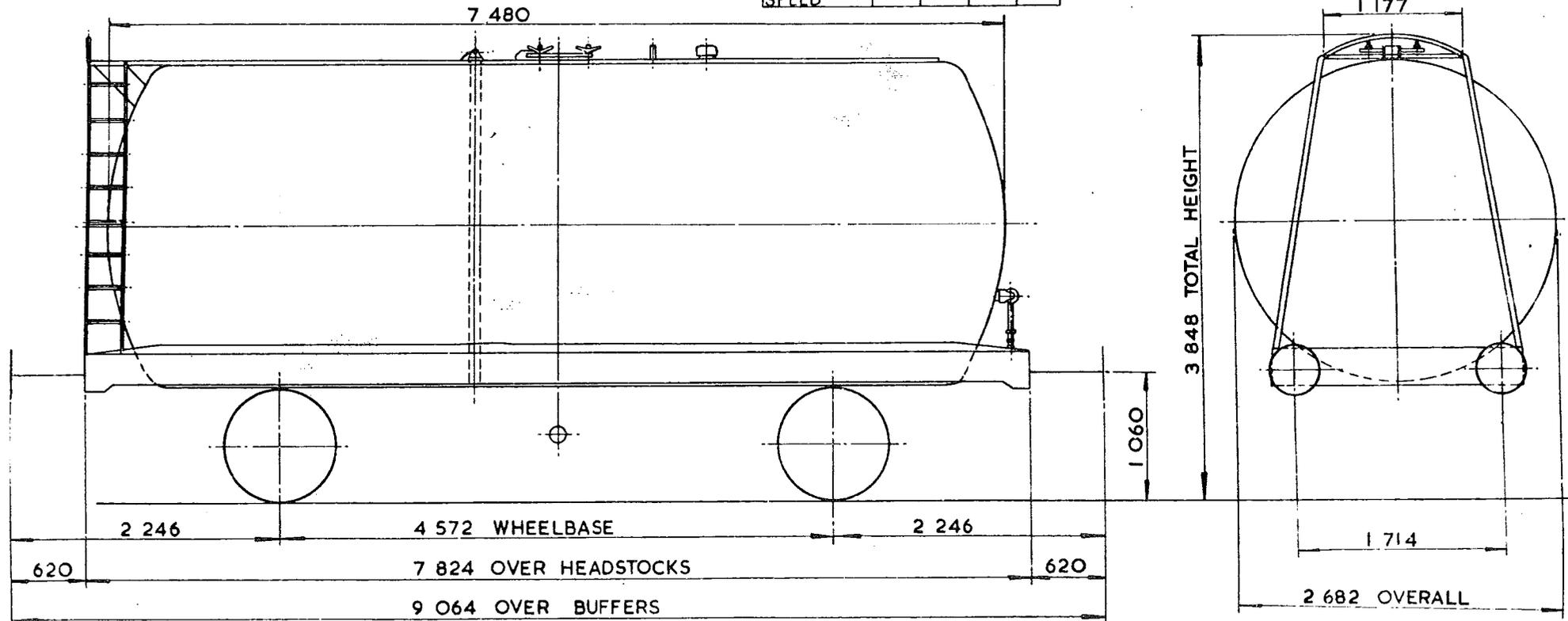

TARE - 14 500 kg
CARRYING CAPACITY - 31 500 kg
CAPACITY - 38 140 litres
MAX SPEED - 60 mile/h
WHEELS - 952 DIA.
JOURNALS - 140 DIA. ROLLER BEARINGS

BUFFERS - HYDRAULIC 406 DIA. HEADS
COUPLINGS - INTERNATIONAL SCREW
MIN. CURVE - 31m
GEN ARRGT. DRG. No. -
BRAKE - VACUUM BLOCK & HAND LEVER
SUSPENSION - DOUBLE LINK

BUILDER - R.Y. PICKERING
OWNER - BRITISH RAILWAY TRAFFIC & ELECTRIC
REGISTERED BY - C.M. & E.E.(B.R.B.) DERBY
YEAR BUILT - 1965
REGISTRATION Nos. - 57061 TO 57075
OWNERS Nos. -

ISSUE 2
EX PO. DIAGRAM 6/167

46 tonnes G.L.W. TANK WAGON-CLASS A

TTO27E

EXCESS LENGTH	4	H	M	L	E
tonnes	46	46	14	14	
VB	19	19	8	8	
AB					
RA	8	8	1	1	
MAX SPEED	60	60	45	45	

TOPS CODE		
CARKND	AARKND	OPERATIONAL PANELING
T	T	F A I S O I

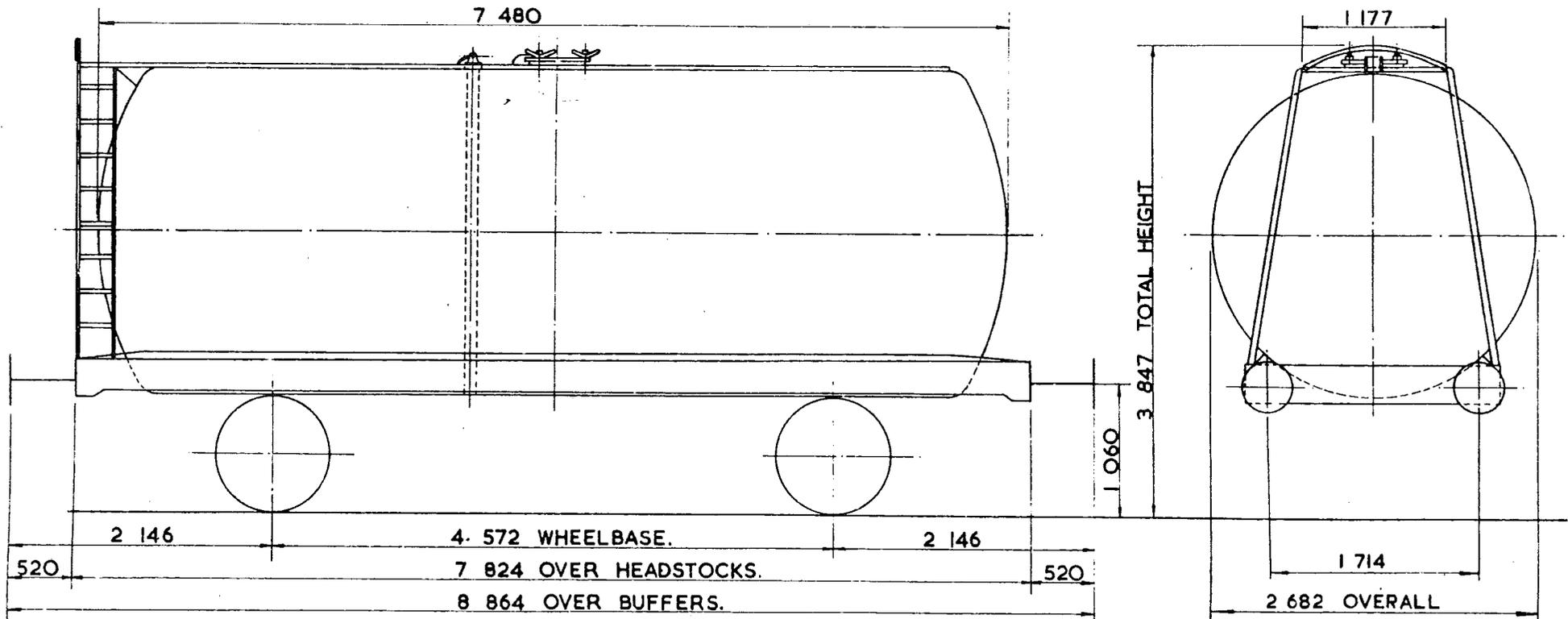

TARE - 13250kg.
CARRYING CAPACITY - 32700kg.
CAPACITY - 39368 litres
MAX SPEED - 60 mile/h.
WHEELS - 952 DIA.
JOURNALS - 140 DIA. ROLLER BEARINGS.

BUFFERS - HYDRAULIC 406 DIA. HEADS
COUPLINGS - INSTANTER.
MIN. CURVE - 31m.
GEN ARRGT. DRG. No. -
BRAKE - VACUUM BLOCK & HAND LEVER
SUSPENSION - DOUBLE LINK.

BUILDER - R.Y. PICKERING.
OWNER - BRITISH RAILWAY TRAFFIC & ELECTRIC.
REGISTERED BY - C.M. & E.E. (B.R.B.) DERBY.
YEAR BUILT - 1965
REGISTRATION Nos. - 57306 & 57307.
OWNERS Nos. - 5986 & 5987

ISSUE 2
EX. P.O. DIAGRAM 6/155

46 tonnes G.L.W. TANK WAGON CLASS 'A'-'B'

TTO27F

EXCESS LENGTH 4	H	M	L	E
tonnes	46	46	13	13
VB	24	24	7	7
AB				
RA	8	8	1	1
MAX. SPEED	60	60	45	45

TOPS CODE										
CARKND	AARKND			OPERATING PANEL No						
T	T	F	T	T	F	A	I	5	2	0

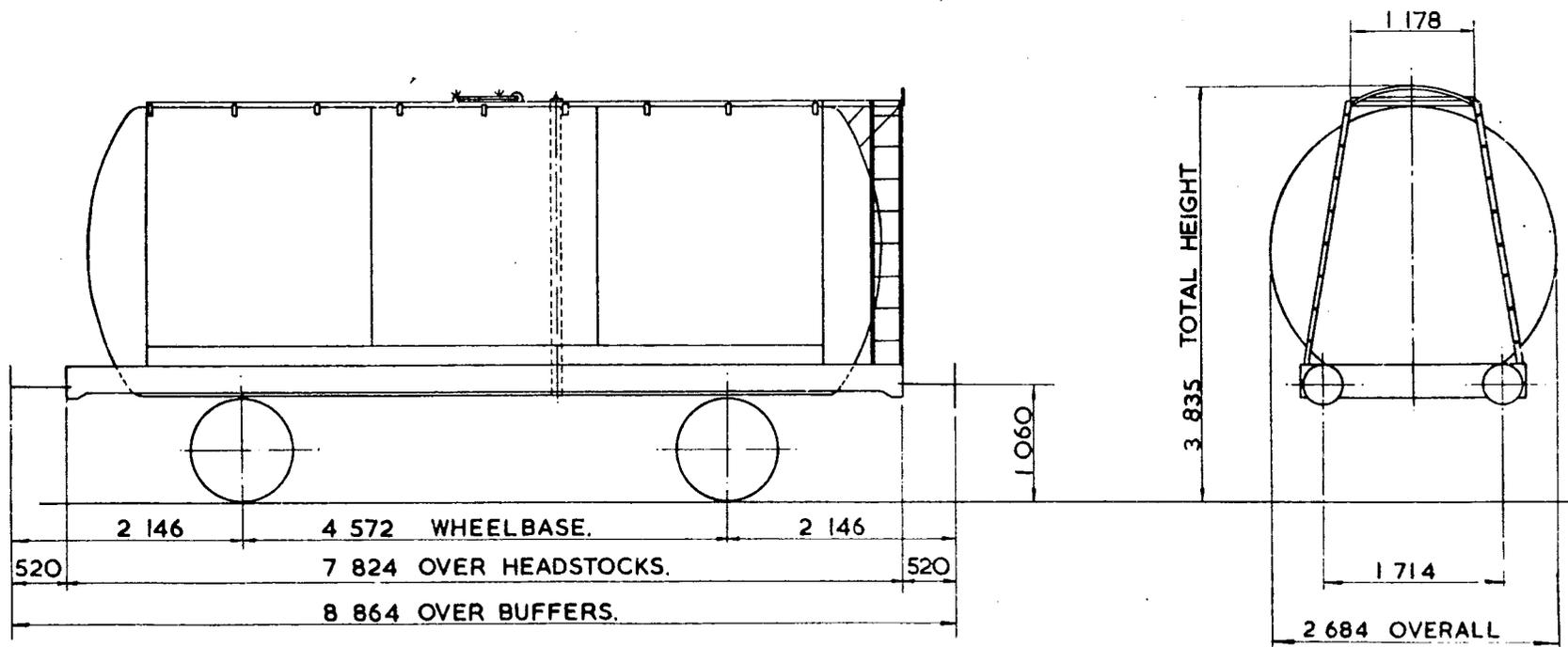

TARE - 13200kg.
CARRYING CAPACITY - 32800kg.
CAPACITY - 37666 litres.
MAX SPEED - 60 mile/h
WHEELS - 952 DIA.
JOURNALS - 140 DIA. ROLLER BEARINGS.

BUFFERS - HYDRAULIC 406 DIA. HEADS
COUPLINGS - INSTANTER.
MIN. CURVE - 31m.
GEN. ARRGT. DRG. No. -
BRAKE - VACUUM BLOCK & HAND LEVER
SUSPENSION - DOUBLE LINK.

BUILDER - R.Y. PICKERING.
OWNER - TEXACO.
REGISTERED BY - CM. & E.E.(B.R.B.) DERBY.
YEAR BUILT - 1965.
REGISTRATION Nos. - 54802 TO 54809, 54847
OWNERS Nos. -

ISSUE 2

EX. P.O. DIAGRAM 6/181 (ALLOCATED.)

46 tonnes GLW. TANK WAGON - CLASS B

TT 027 J

EXCESS LENGTH	5	H	M	L	E
tonnes	46	46	15	15	
VB	0	0	0	0	
AB	25	25	9	9	
RA	8	8	1	1	
MAX. SPEED	60	60	45	45	

TOPS CODE						
CARKND	AARKND		OPERATING PANEL No			
T T B	T T B	A	1	3	5	7

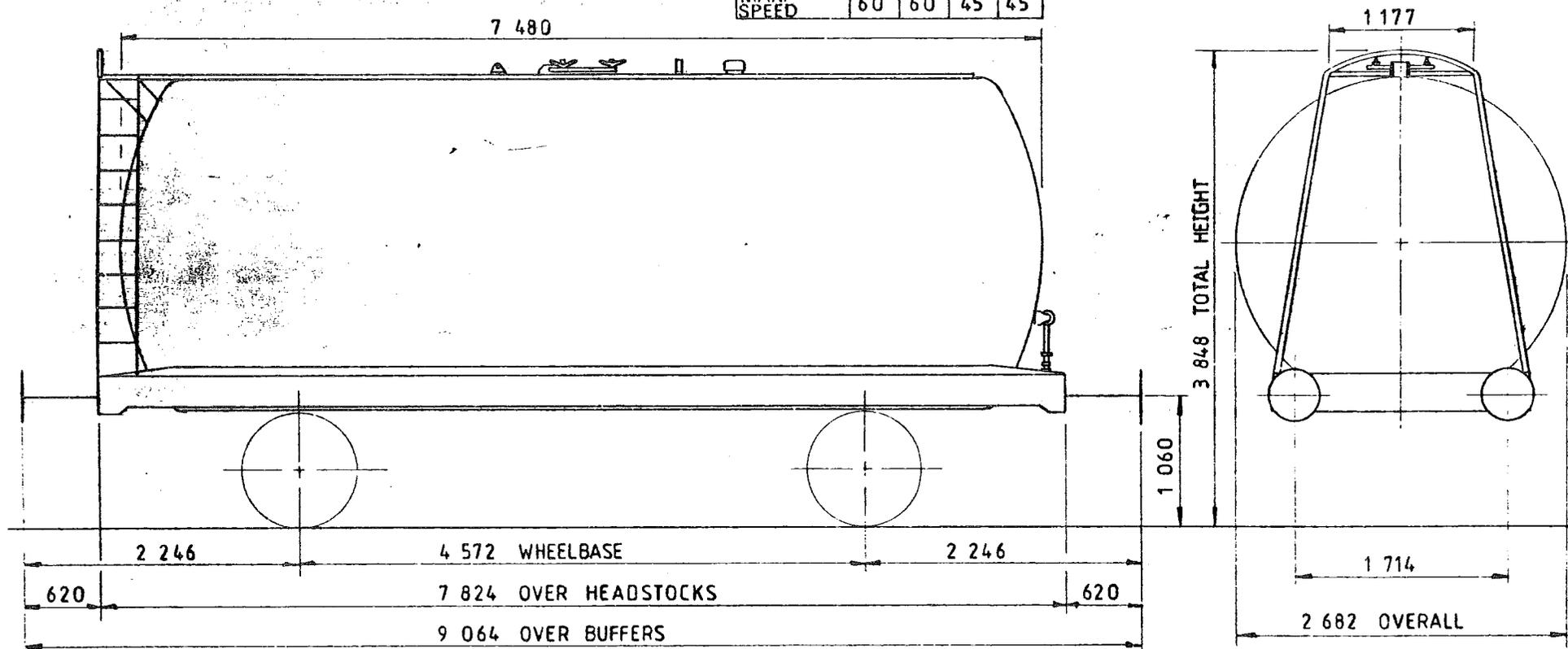

TARE -	14 500 kg
CARRYING CAPACITY -	31 500 kg
CAPACITY -	38 140 litres
MAX. SPEED -	60 mile /h
WHEELS -	952 DIA.
JOURNALS -	140 DIA. ROLLER BEARINGS

BUFFERS	HYDRAULIC 406 DIA HEADS
COUPLINGS -	INTERNATIONAL SCREW
MIN. CURVE -	31m
GEN ARRGT. DRG No. -	
BRAKE -	AIR BLOCK, VACUUM PIPED & HAND LEVER
SUSPENSION -	DOUBLE LINK

issue 1

46 tonnes GLW. TANK WAGON - CLASS B

TT 027K

EXCESS LENGTH	5	H	M	L	E
tonnes	46	46	15	15	
VB					
AB	26	26	10	10	
RA	8	8	1	1	
MAX SPEED	60	60	45	45	

TOPS CODE					
CARKND	AARKND	OPERATING PANEL No			
T	T	A	T	A	A
1	4	5	9		

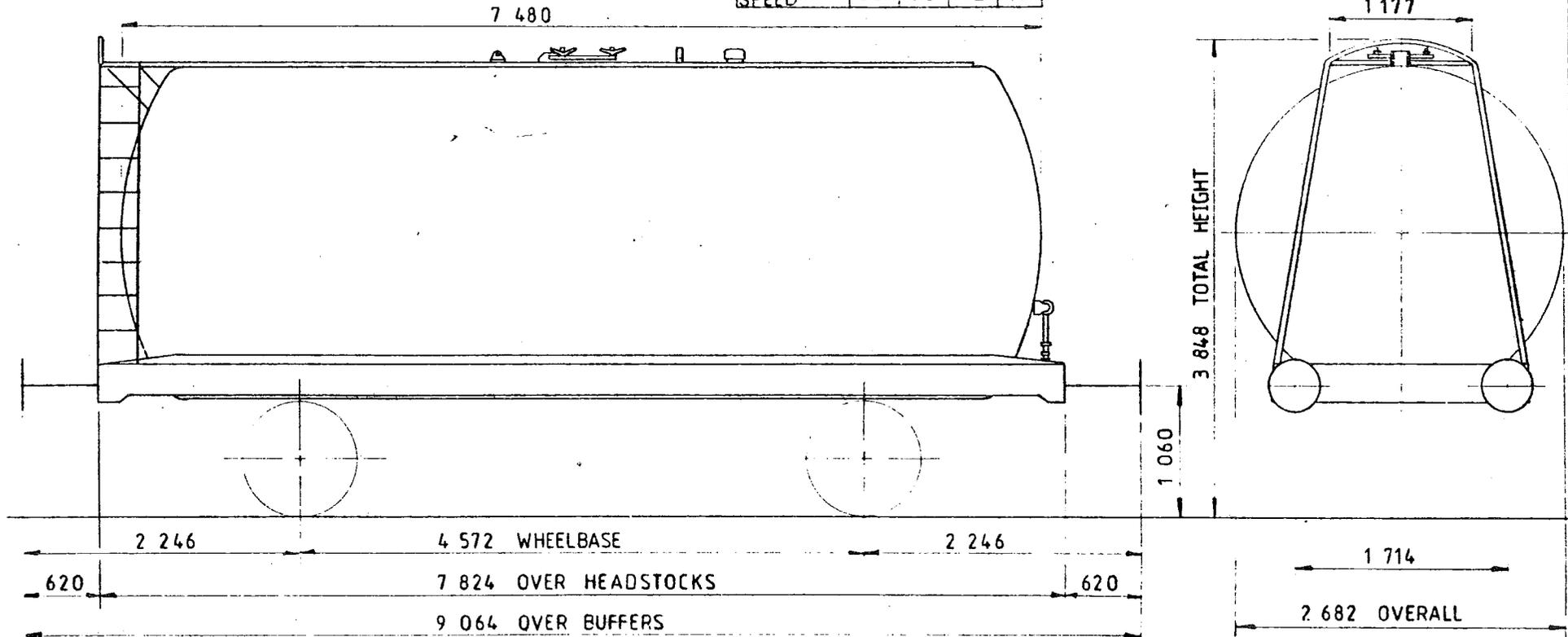

TARE -	14,500 kg
CARRYING CAPACITY -	31,500 kg
CAPACITY -	38,140 litres
MAX SPEED -	60 mile/h
WHEELS -	952 DIA.
JOURNALS -	140 DIA ROLLER BEARINGS

BUFFERS	HYDRAULIC 406 DIA HEADS
COUPLINGS	INTERNATIONAL SCREW
MIN CURVE	31m
GEN ARRGT DRG No	
BRAKE	AIR BLOCK & HAND LEVER
SUSPENSION	DOUBLE LINK

issue 1

46 tonnes G.L.W. TANK WAGON

TT027L

EXCESS LENGTH	4	H	M	L	E
tonnes	46	46	13	13	
VB	21	21	8	8	
AB					
RA	8	8	1	1	
MAX SPEED	60	60	45	45	

TOPS CODE										
CARKND		AARKND			ERRATA PAGE N					
T	T	F	T	T	F	A	1	3	0	1

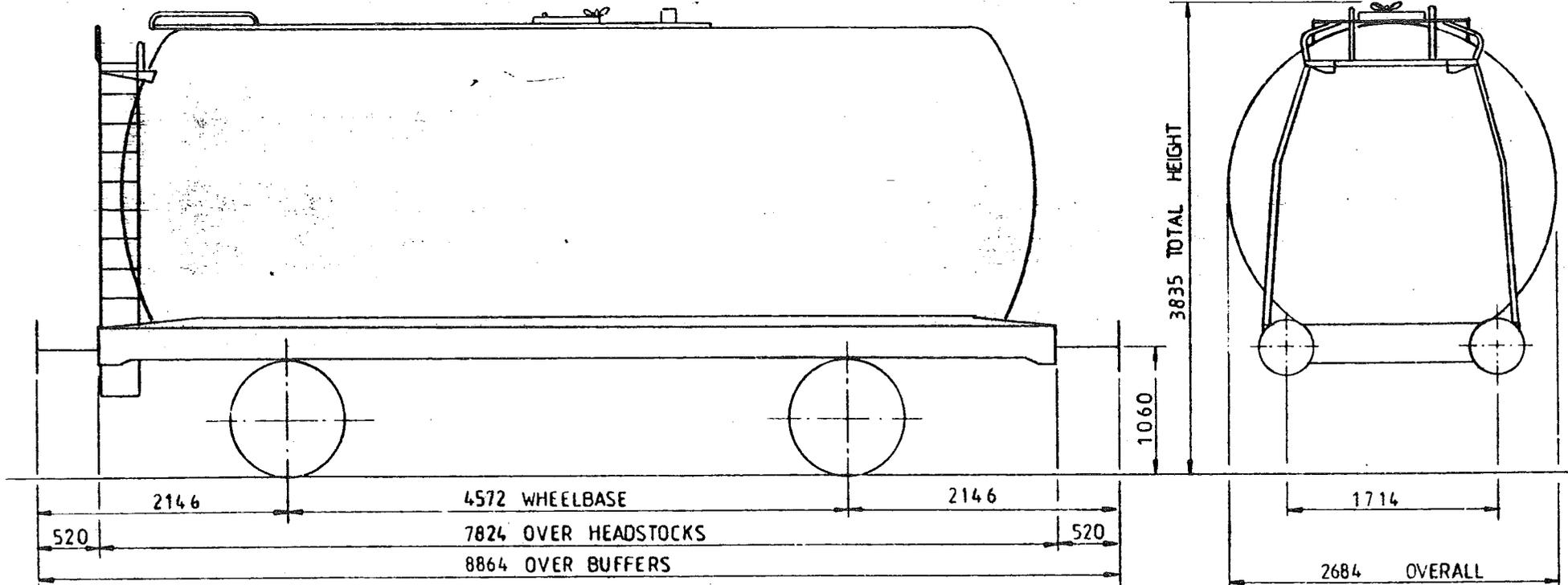

TARE	13200 kg
CARRYING CAPACITY	32000 kg
CAPACITY	37686 Litres
MAX SPEED	60 mile/h
WHEELS	φ 952
JOURNALS	φ140 ROLLER BEARINGS

BUFFERS	HYDRAULIC φ406 HEADS
COUPLINGS	INSTANTER
MIN CURVE	31 m
GEN ARRGT DRG No	
BRAKE	A.F.I. VACUUM BLOCK, HAND LEVER
SUSPENSION	DOUBLE LINK

ISSUE 1

EX PO DIAGRAM 6/181 (ALLOCATED)

46 tonnes G.L.W. TANK WAGON

TT027M

EXCESS LENGTH 4	H	M	L	E
tonnes	46	46	13	13
VB	24	24	7	7
AB				
RA	8	8	1	1
MAX SPEED	60	60	45	45

TOPS CODE										
CARKND		AARKND			OPERATING PANEL No					
T	T	F	T	T	F	A	1	5	2	0

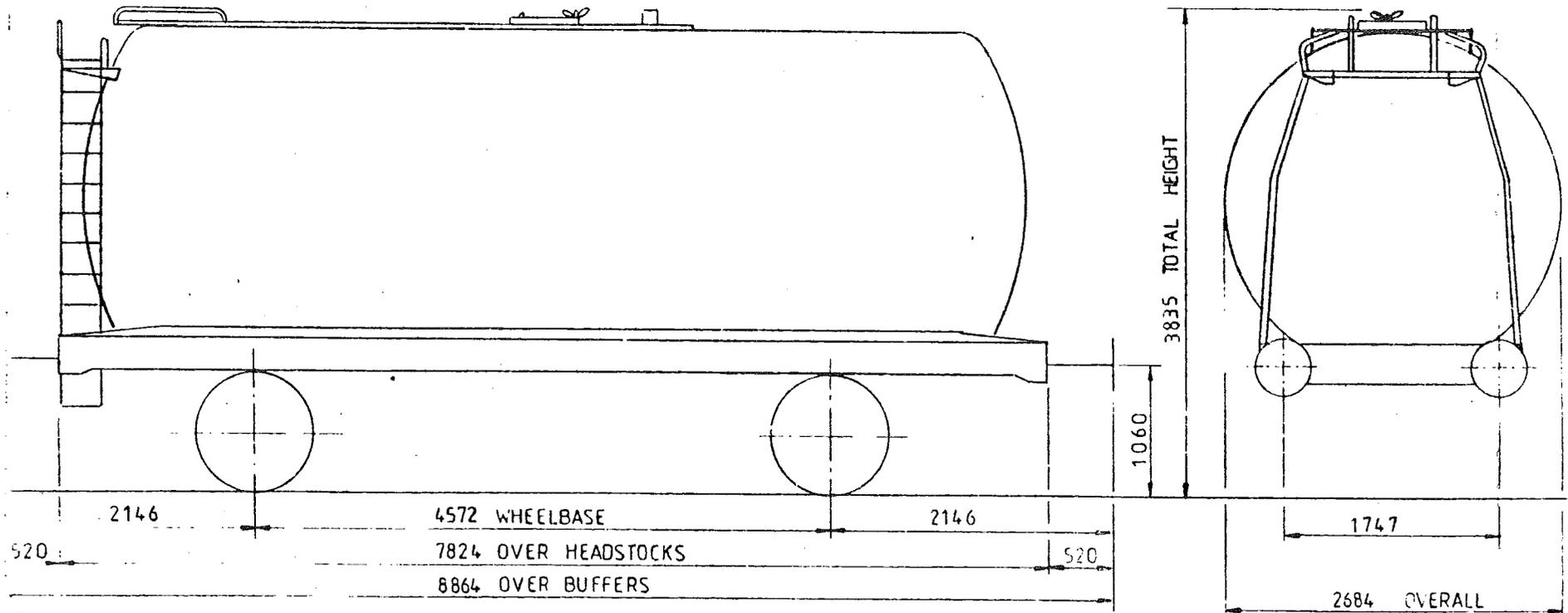

TARE	13 ⁺⁵⁰ kg
CARRYING CAPACITY	32 ⁵⁰⁰ kg
CAPACITY	37686 Litres
MAX SPEED	60 mile/h
WHEELS	φ 952
JOURNALS	φ140 ROLLER BEARINGS

BUFFERS	HYDRAULIC φ406 HEADS
COUPLINGS	INSTANTER
MIN CURVE	31 m
GEN ARRGT DRG No	
BRAKE	A.F.I. VACUUM BLOCK, HAND LEVER
SUSPENSION	DOUBLE LINK

ISSUE 1

46 tonne GLW TANK WAGON

LOT NUMBER	

TOPS INFORMATION										
AARKND	OPERATING PANEL No.			OPERATING SPEED		BRAKE FORCE DATA		EXCESS LENGTH	RA (GLW)	DESIGN SHEET
				60 mile/h UP TO	46 tonne GLW	5 t FORCE UP TO	30.5 tonne GLW	4	9	W1180
T T A A				mile/h ABOVE		22t FORCE ABOVE				

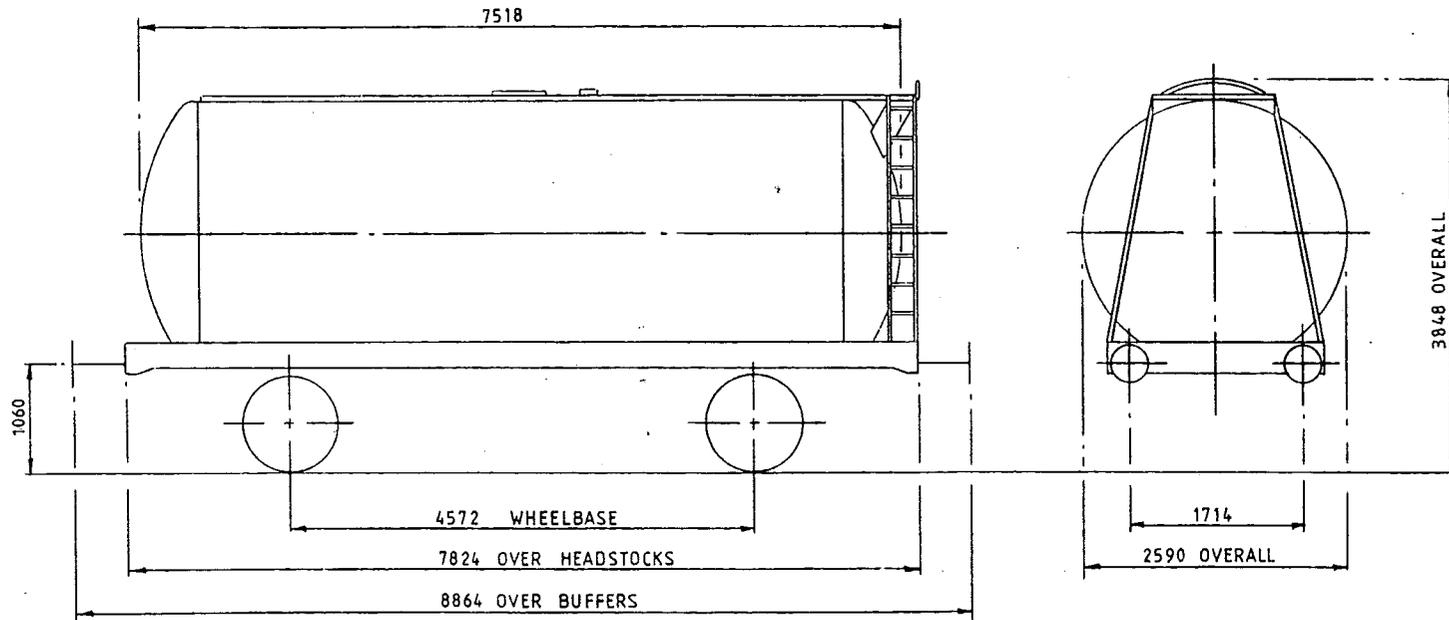

TARE-	13.500 Kg
CAPACITY, WEIGHT-	31.300 Kg
CAPACITY, VOLUME-	38.641 litres
MIN. CURVE-	31m
GEN. ARRGT. DRG. NO.-	

BRAKE-	AIR BLOCK & HAND LEVER
SUSPENSION-	DOUBLE LINK
COUPLINGS-	INSTANTER
BUFFERS-	HYDRAULIC 406 DIA HEADS
WHEELS-	952 DIA
JOURNALS-	140 DIA ROLLER BEARINGS

ISSUE 1

46 tonne GLW TANK WAGON-CLASS 'B'

LOT NUMBER	

TOPS INFORMATION								
AARKND	OPERATING	OPERATING SPEED		BRAKE FORCE DATA		EXCESS	RA	DESIGN
CARKND	PANEL No.	60 mile/h UP TO	46 tonne GLW	5 t FORCE UP TO	30.5 tonne GLW	LENGTH	(GLW)	SHEET
T T A A		mile/h ABOVE		22t FORCE ABOVE		4	9	W1181

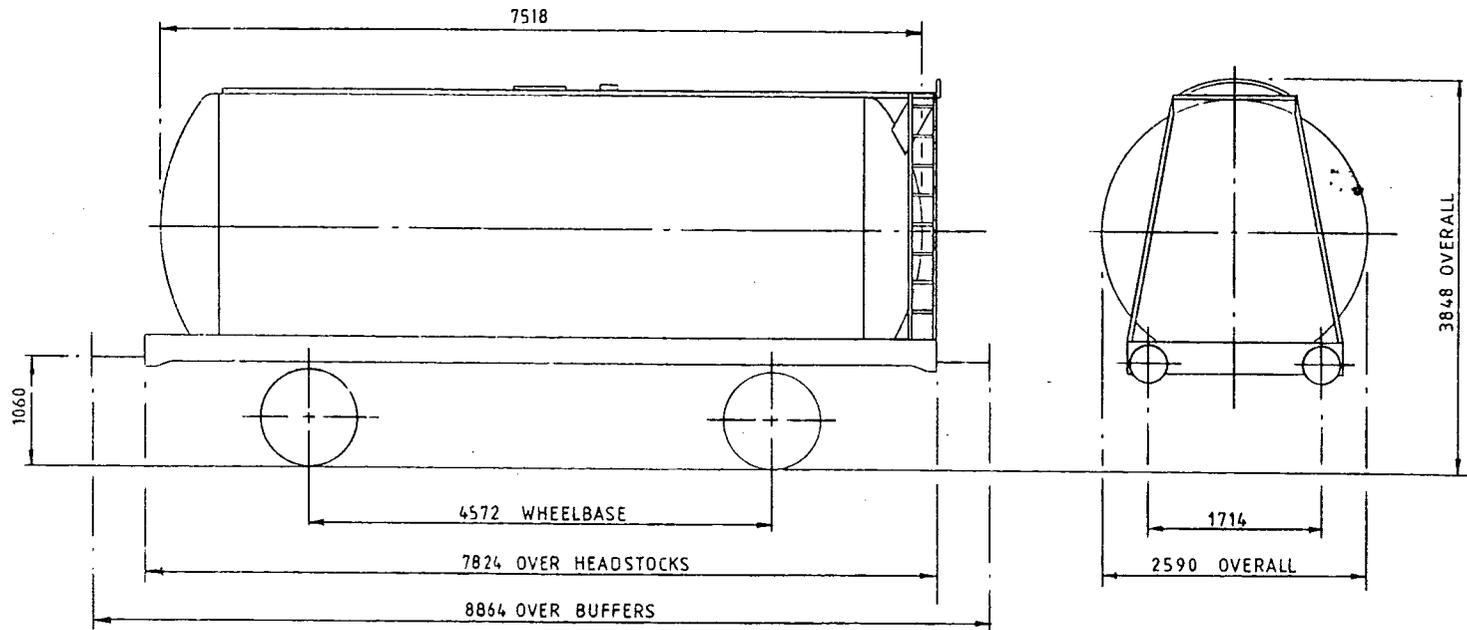

TARE-	12.850 Kg
CAPACITY, WEIGHT-	33.150 Kg
CAPACITY, VOLUME-	38.186 litres
MIN. CURVE-	31 m
GEN. ARRGT. DRG. NO.-	

BRAKE-	AIR BLOCK & HAND LEVER
SUSPENSION-	DOUBLE LINK
COUPLINGS-	INSTANTER
BUFFERS-	HYDRAULIC 406 DIA HEADS
WHEELS-	952 DIA
JOURNALS-	140 DIA ROLLER BEARINGS

ISSUE 1

46 tonne GLW TANK WAGON

LOT NUMBER	

TOPS INFORMATION						
AARKND	OPERATING		OPERATING SPEED		BRAKE FORCE DATA	
CARKND	PANEL No.		60 mile/h UP TO	46 tonne GLW	10t FORCE UP TO	EXCESS LENGTH
T T B A			mile/h ABOVE		23t FORCE ABOVE	4
					31 tonne GLW	RA (GLW)
						8
						DESIGN SHEET
						W1274

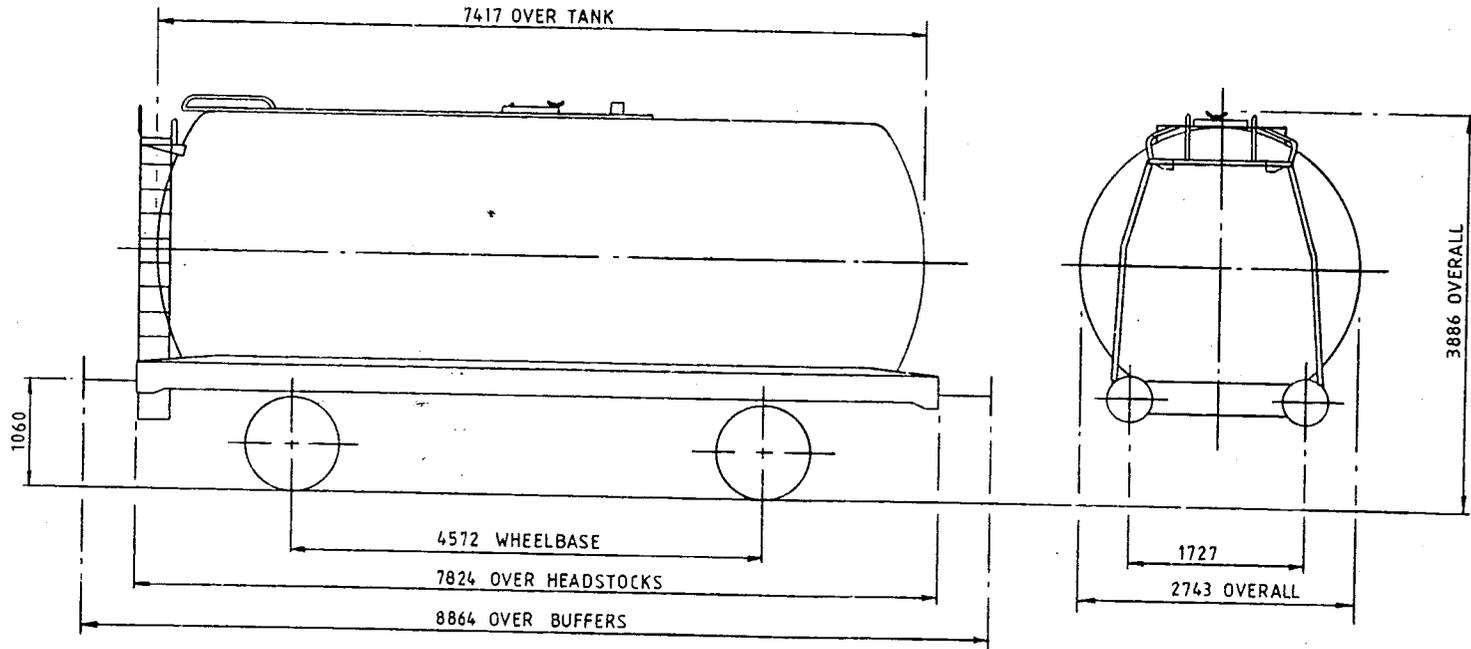

TARE-	13.000 Kg
CAPACITY, WEIGHT-	33.000 Kg
CAPACITY, VOLUME-	38.413 litres
MIN. CURVE-	31 m
GEN. ARRGT. DRG. NO.-	

BRAKE-	AIR BLOCK, VAC PIPE, HAND LEVER
SUSPENSION-	DOUBLE LINK & PARABOLIC SPRING
COUPLINGS-	INSTANTER
BUFFERS-	HYDRAULIC 406 DIA HEADS
WHEELS-	952 DIA
JOURNALS-	140 DIA ROLLER BEARINGS

ISSUE 1

46 tonnes G.L.W. TANK WAGON - CLASS B

TT028 A

EXCESS LENGTH	4	H	M	L	E
tonnes	46	46	15	15	
VB	20	20	8	8	
AB					
RA	8	8	1	1	
MAX. SPEED	60	60	45	45	

TOPS CODE					
CARKND	AARKND	OPERATING PANEL No			
T	T	F	A	1	5
				2	2

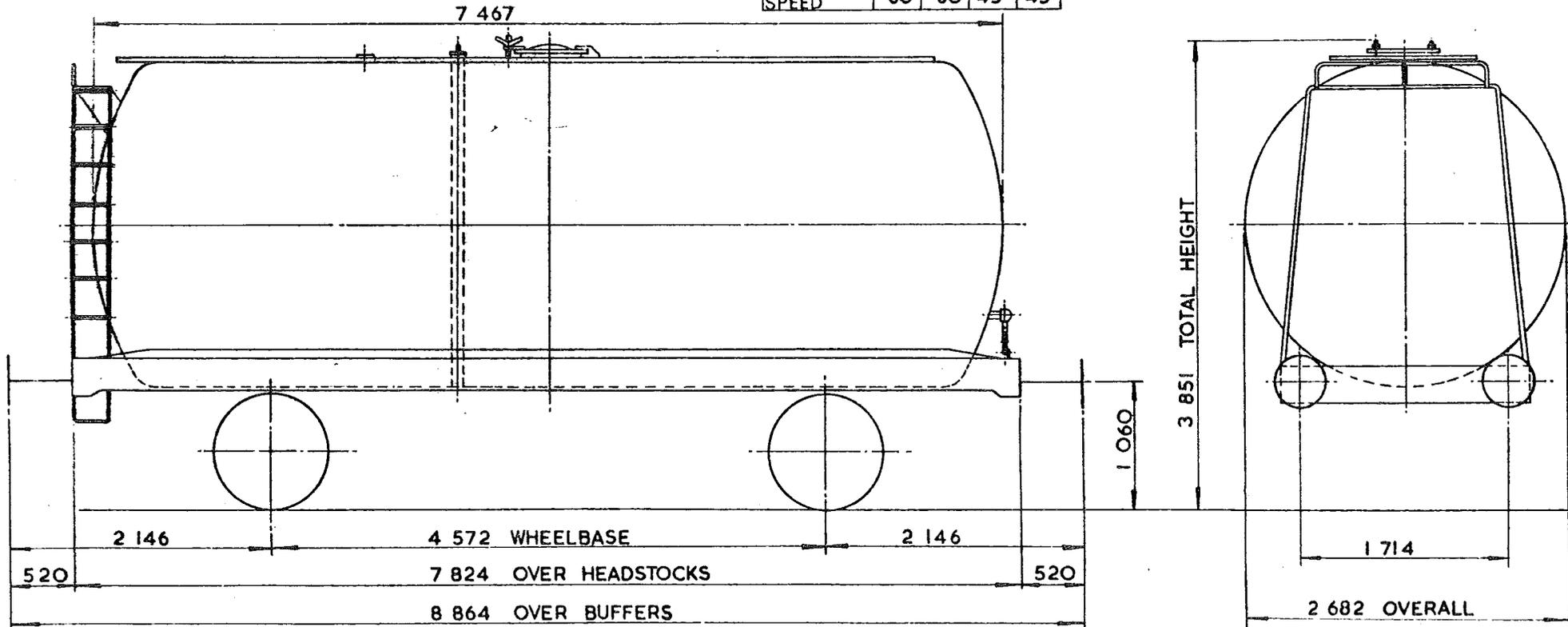

TARE - 14 750 kg
CARRYING CAPACITY - 31 200 kg
CAPACITY - 38 822 litres
MAX. SPEED - 60 mile/h
WHEELS - 952 DIA.
JOURNALS - 140 DIA. ROLLER BEARINGS

BUFFERS - HYDRAULIC 406 DIA. HEADS
COUPLINGS - INSTANTER
MIN. CURVE - 31m
GEN. ARRGT. DRG. No. -
BRAKE - VACUUM BLOCK & HAND LEVER
SUSPENSION - DOUBLE LINK

BUILDER - PRESSED STEEL
OWNER - BRITISH RAILWAY TRAFFIC ELECTRIC
REGISTERED BY - C.M. & E.E. (B.R.B.) DERBY
YEAR BUILT - 1965
REGISTRATION Nos. - 57193
OWNERS Nos. - 5759

ISSUE 2

EX RO. DIAGRAM 6/169

46 tonnes G.L.W. TANK WAGON - SULPHURIC ACID

TTO29A

EXCESS LENGTH 4	H	M	L	E
tonnes	46	46	13	13
VB	19	19	8	8
AB				
RA	8	8	1	1
MAX. SPEED	60	60	45	45

TOPS CODE								
CARKND			AARKND			OPERATING PANEL No		
T	T	F	T	T	F	A	1	5
							1	9

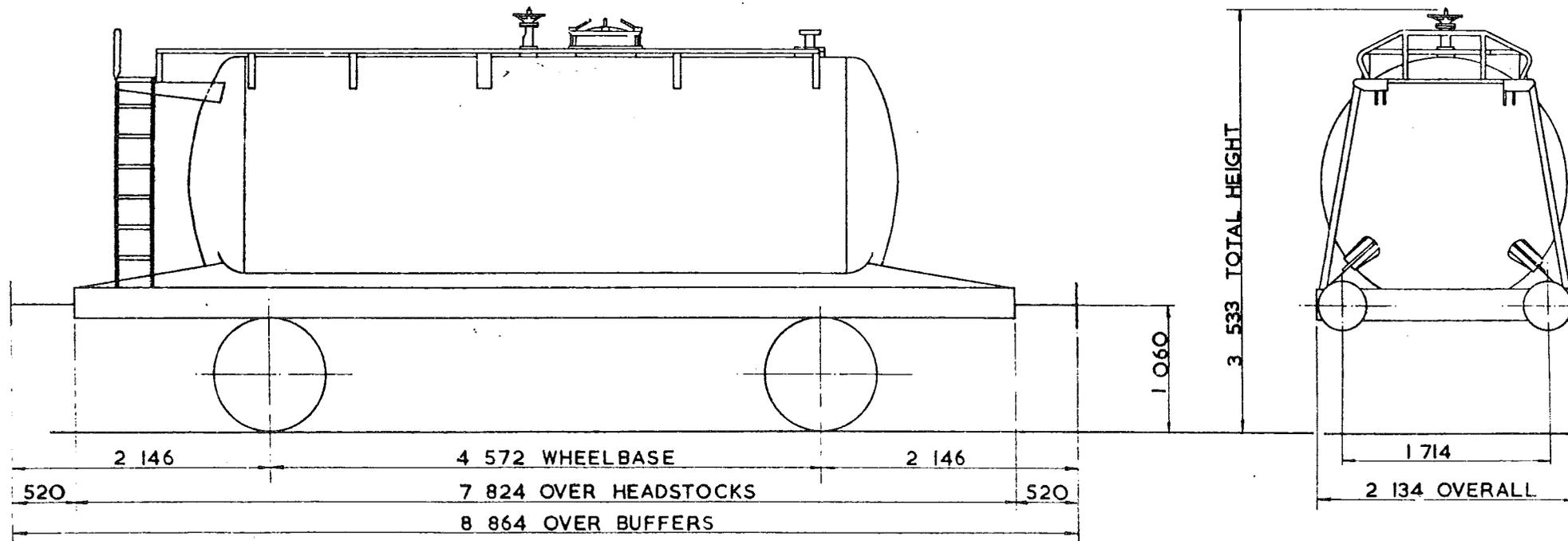

TARE - 13 200kg.
CARRYING CAPACITY - 32 800kg
CAPACITY - 18 297 litres.
MAX. SPEED - 60 mile/h.
WHEELS - 952 DIA.
JOURNALS - 140 DIA. ROLLER BEARINGS.

BUFFERS - HYDRAULIC 406 DIA. HEADS.
COUPLINGS - INSTANTER.
MIN. CURVE - 31m.
GEN. ARRGT. DRG. No. -
BRAKE - VACUUM BLOCK & HAND LEVER.
SUSPENSION - DOUBLE LINK.

BUILDER - POWELL DUFFRYN.
OWNER - BRITISH RAILWAY TRAFFIC & ELECTRIC.
REGISTERED BY - C.M. & E.E. (B.R.B.) DERBY.
YEAR BUILT - 1966.
REGISTRATION Nos - 57308 TO 57322
OWNERS Nos - 5988 TO 6002

ISSUE 2

EX. P.O. DIAGRAM 6/634 (ALLOCATED)

46 tonnes G.L.W. TANK WAGON - CLASS A.

TTO29C

EXCESS LENGTH	4	H	M	L	E
tonnes	46	46	14	14	
VB	22	22	13	13	
AB	0	0	0	0	
RA	8	8	1	1	
MAX. SPEED	60	60	45	45	

TOPS CODE		
CARKND	AARKND	OPERATING PANEL No
T T G T T G A	I 5 0 7	

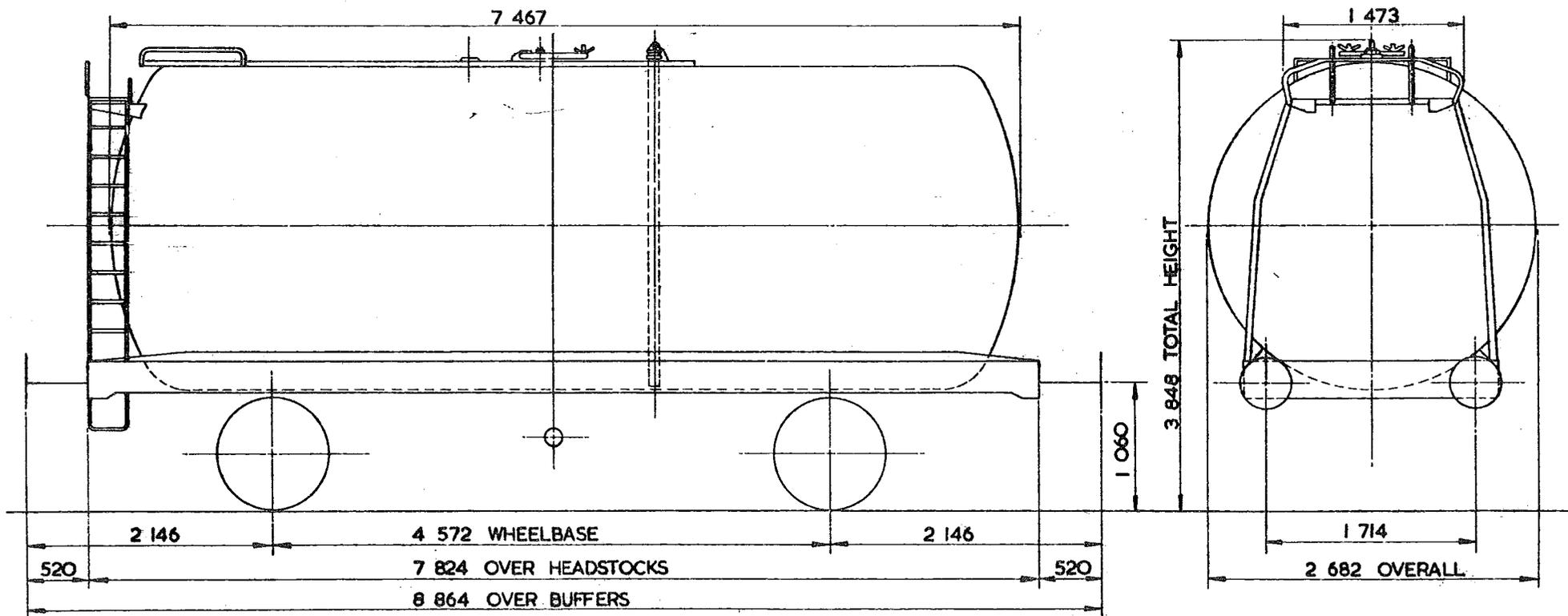

TARE -	14200 kg
CARRYING CAPACITY -	31800
CAPACITY -	39550 litres
MAX. SPEED -	60 mile/h
WHEELS -	952 DIA
JOURNALS -	140 DIA ROLLER BEARINGS

BUFFERS -	HYDRAULIC 406 DIA HEADS
COUPLINGS -	INSTANTER
MIN. CURVE -	31 m
GEN. ARRGT. DRG. No. -	
BRAKE -	VACUUM BLOCK, AIR PIPED & HAND LEVER
SUSPENSION -	DOUBLE LINK

BUILDER -	POWELL DUFFRYN
OWNER -	B.R.T. & E.
REGISTERED BY -	C.M. & E.E. (B.R.B.) DERBY
YEAR BUILT -	1965
REGISTRATION Nos. -	57092 TO 57127 (RANGE).
OWNERS Nos. -	5658 TO 5693 (RANGE).

46 tonnes G.L.W. TANK WAGON-CLASS A.

TTO29D

EXCESS LENGTH	4	H	M	L	E
tonnes	46	46	14	14	
VB	20	20	8	8	
AB					
RA	8	8	1	1	
MAX. SPEED	60	60	45	45	

TOPS CODE					
CARKND	AARKND	OPERATING PANEL No.			
T	T	F	T	F	A
1	5	0	2		

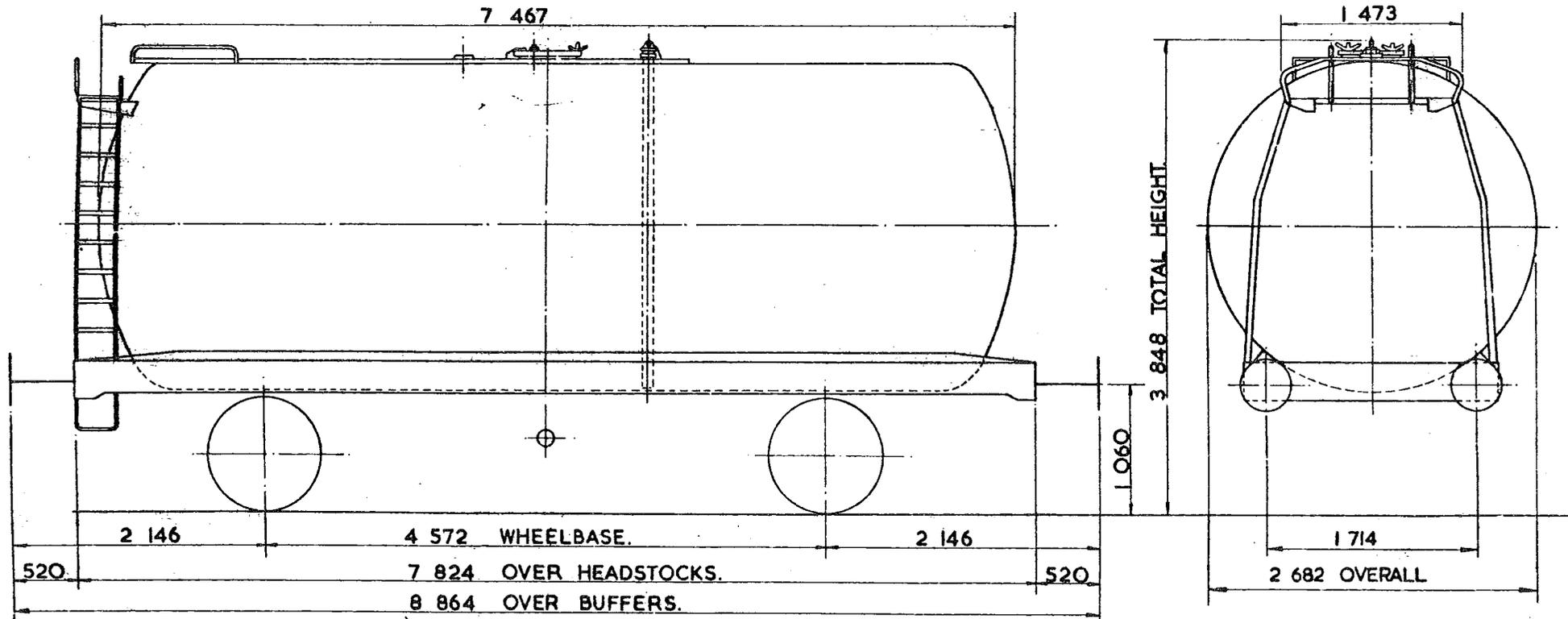

TARE - 14200kg.
CARRYING CAPACITY - 31800kg.
CAPACITY - 39550 litres
MAX. SPEED - 60 mile/h.
WHEELS - 952 DIA.
JOURNALS - 140 DIA. ROLLER BEARINGS.

BUFFERS - HYDRAULIC 406 DIA. HEADS.
COUPLINGS - INSTANTER.
MIN. CURVE - 31m.
GEN. ARRGT. DRG. No. -
BRAKE - VACUUM. BLOCK & HAND LEVER.
SUSPENSION - DOUBLE LINK.

BUILDER - POWELL DUFFRYN.
OWNER - BRITISH RAILWAY TRAFFIC & ELECTRIC.
REGISTERED BY - C.M. & E.E.(B.R.B.)DERBY.
YEAR BUILT - 1965/66.
REGISTRATION Nos. - 57088 TO 57141. (RANGE)
OWNERS Nos. - 5654 TO 5707. (RANGE)

ISSUE 2
EX. PO. DIAGRAM 6/156

46 tonnes GLW TANK WAGON

TT 029 K

EXCESS LENGTH	5	H	M	L	E
tonnes	46	46	13	13	
VB	19	19	8	8	
AB					
BA	8	8	1	1	
MAX SPEED	60	60	45	45	

TOPS CODE										
CARKND		AARKND			OPERATING PANEL N°					
T	T	F	T	T	F	A	1	4	7	2

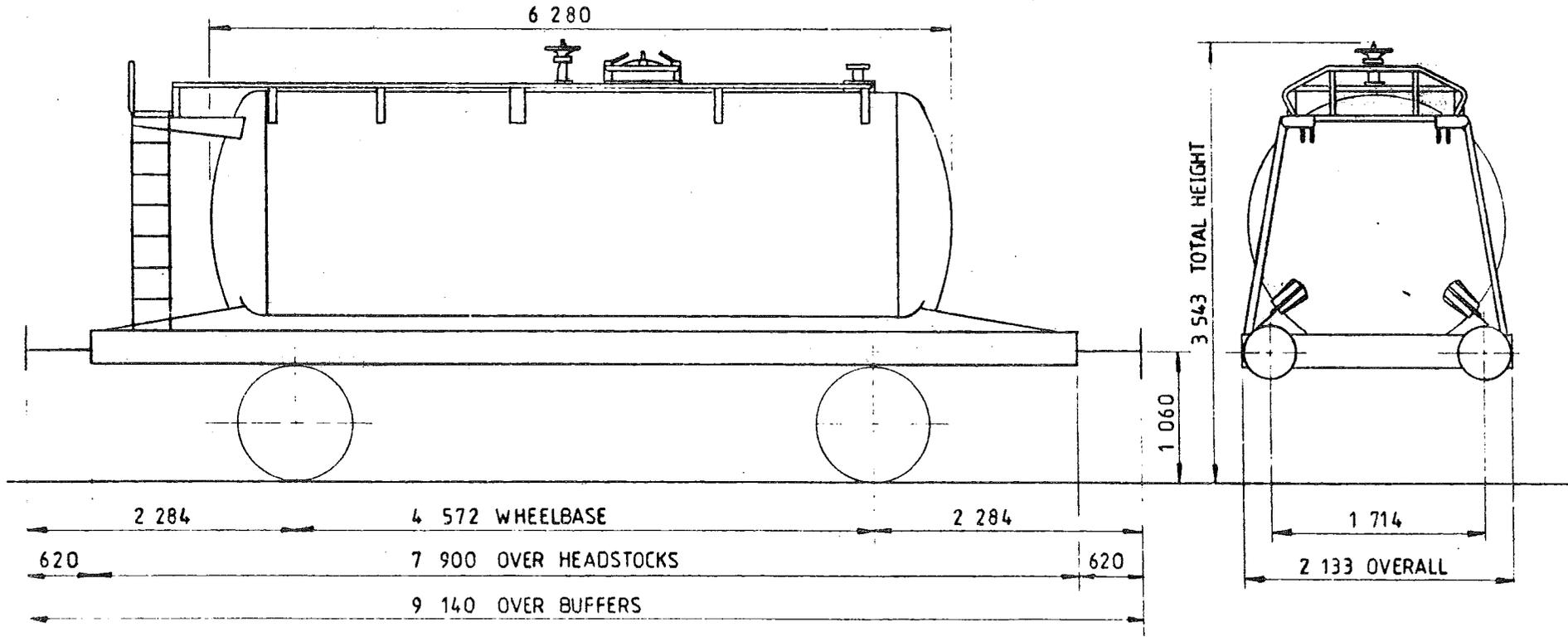

TARE	13 200 kg
CARRYING CAPACITY	32 800 kg
CAPACITY	19 543 litres
MAX SPEED	60 mile/h
WHEEL DIA.	952 DIA.
BEARINGS	140 ROLLER BEARINGS

WHEELS	HYDRAULIC 406 DIA HEADS
TOPS CODE	INTERNATIONAL SCREW
MIN GUNGE	31 m.
GEN ARRIVAL ORG No	
BRAKE	VACUUM BLOCK & HAND LEVER
SUSPENSION	DOUBLE LINK

Issue 1

EX PO. DIAGRAM 61196

46 tonnes G.L.W. TANK WAGON

TT029L

EXCESS LENGTH	4	H	M	L	E
tonnes	46	46	14	14	
VB	0	0	0	0	
AB	21	21	7	7	
RA	8	8	1	1	
MAX SPEED	60	60	45	45	

TOPS CODE	
CARKND	AARKND
TTBTTBTA1304	

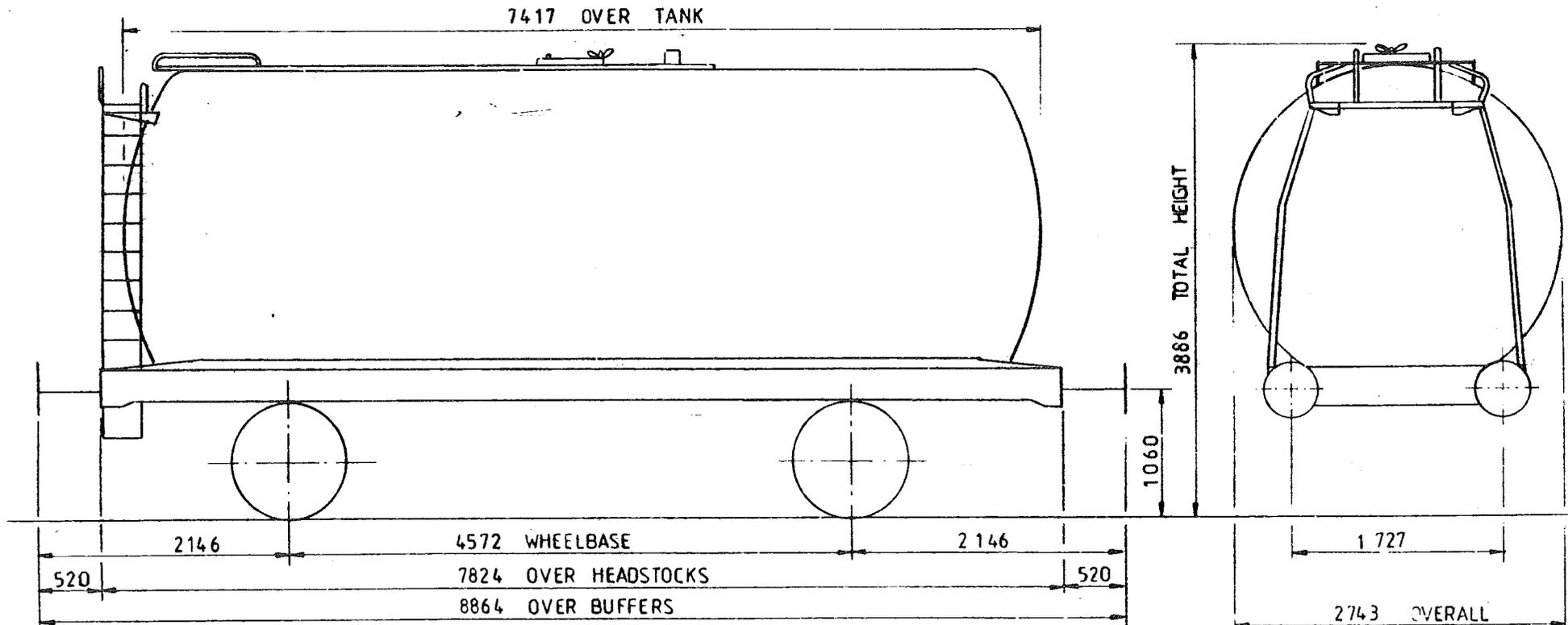

TARE	13450 kg
CARRYING CAPACITY	32000 kg
CAPACITY -	38413 Litres
MAX SPEED	60 mile/h
WHEELS	φ 952
JOURNALS	φ140 ROLLER BEARINGS

BUFFERS	HYDRAULIC φ406 HEADS
COUPLINGS	INSTANTER
MIN CURVE	31 m
GEN ARRGT DRG No	
BRAKE	AIR BLOCK, VAC PIPE, HAND LEVER
SUSPENSION	DOUBLE LINK

ISSUE 1

46 tonnes G.L.W. TANK WAGON CLASS B

TT029Q

EXCESS LENGTH	4	H	M	L	E
tonnes	46	46	13	13	
VB					
AB	22	22	8	8	
RA	8	8	1	1	
MAX SPEED	60	60	60	60	

TOPS CODE										
CARKND	AARKND									
T	T	A	T	T	A	A	1	6	3	4

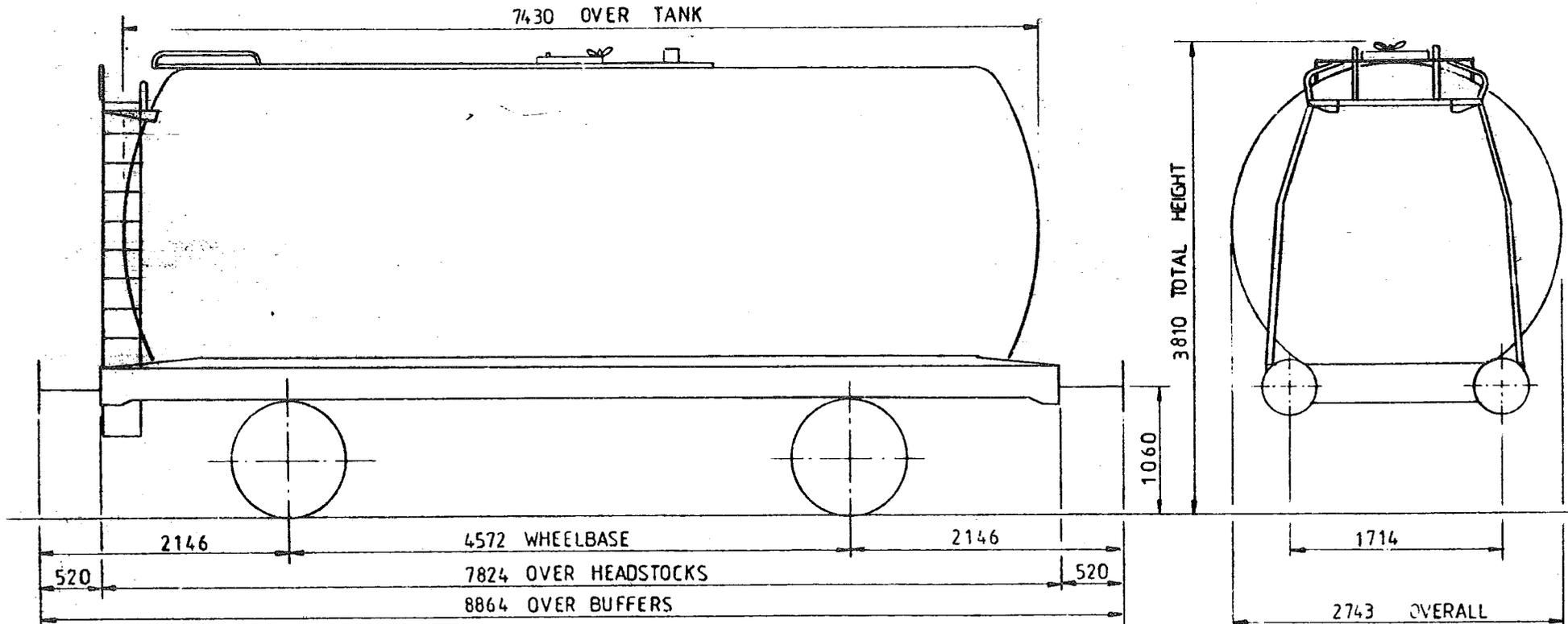

TARE	13 300 kg
CARRYING CAPACITY	32 700 kg
CAPACITY -	43785 Litres
MAX SPEED	60 mile/h
WHEELS	φ 952
JOURNALS	φ124 ROLLER BEARINGS

BUFFERS	HYDRAULIC φ406 HEADS
COUPLINGS	INSTANTER
MIN CURVE	31 m
GEN ARRGT DRG No	
BRAKE	AIR BLOCK, HAND LEVER
SUSPENSION	DOUBLE LINK AND PARABOLIC TAPERLEAF SPRINGS

ISSUE 1

EX PO DIAGRAM 6/679 (ALLOCATED)

46 tonnes G.L.W. TANK WAGON CLASS B

TT029R

EXCESS LENGTH	4	H	M	L	E
tonnes	46	46	13	13	
VB					
AB	22	22	7	7	
RA	8	8	1	1	
MAX SPEED	60	60	45	45	

TOPS CODE					
CARKND	AARKND				
T	T	A	T	A	A 1 5 8 6

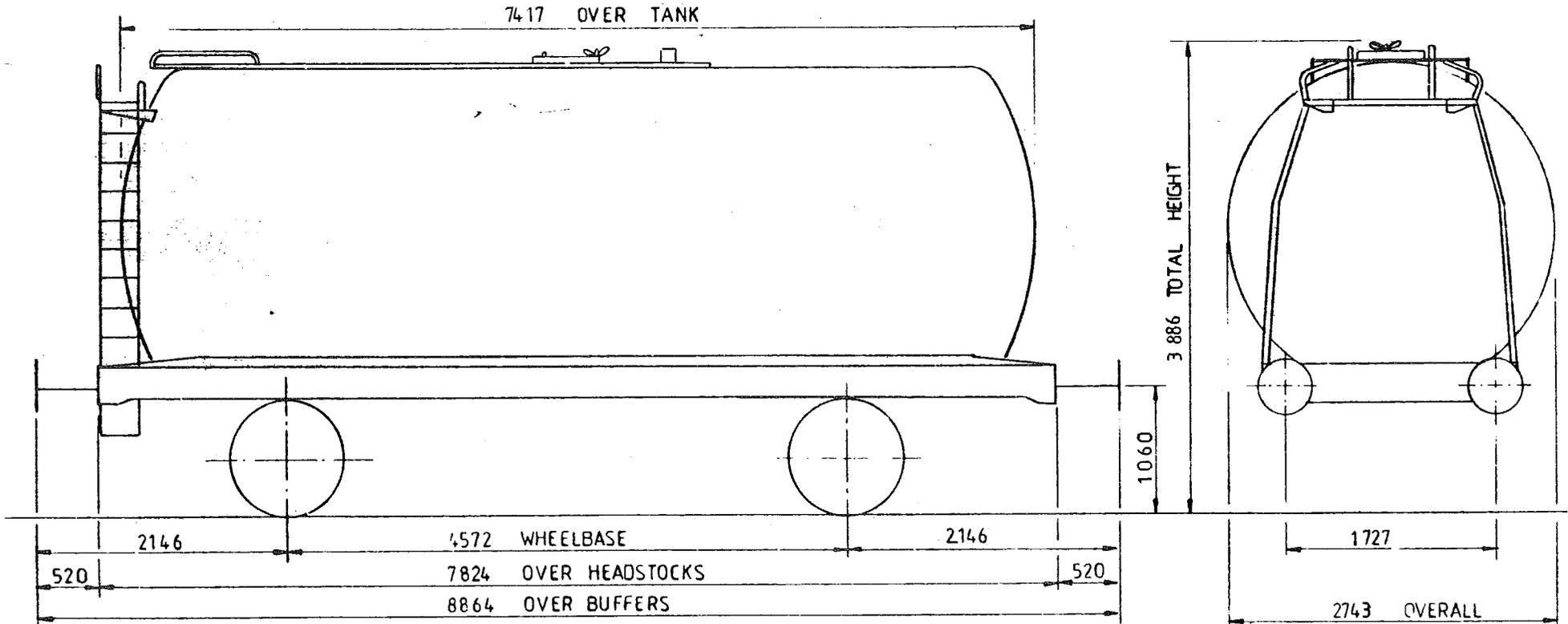

TARE	13000 kg
CARRYING CAPACITY	32900 kg
CAPACITY -	Litres
MAX SPEED	60 mile/h
WHEELS	φ 952
JOURNALS	φ140 ROLLER BEARINGS

BUFFERS	HYDRAULIC φ406 HEADS
COUPLINGS	INSTANTER
MIN CURVE	31 m
GEN ARRGT DRG No.	
BRAKE	AIR BLOCK HAND LEVER
SUSPENSION	FAT 26

ISSUE 1

EX PO DIAGRAM 6/179 (ALLOCATED)

46 tonnes G.L.W. TANK WAGON

TT030D

EXCESS LENGTH	L	H	M	L	E
tonnes	46	46	11	11	
VB					
AB	22	22	8	8	
RA	8	8	1	1	
MAX SPEED	60	60	60	60	

TOPS CODE				
CARKND	AARKND
T	T	A	A	1 5 7 0

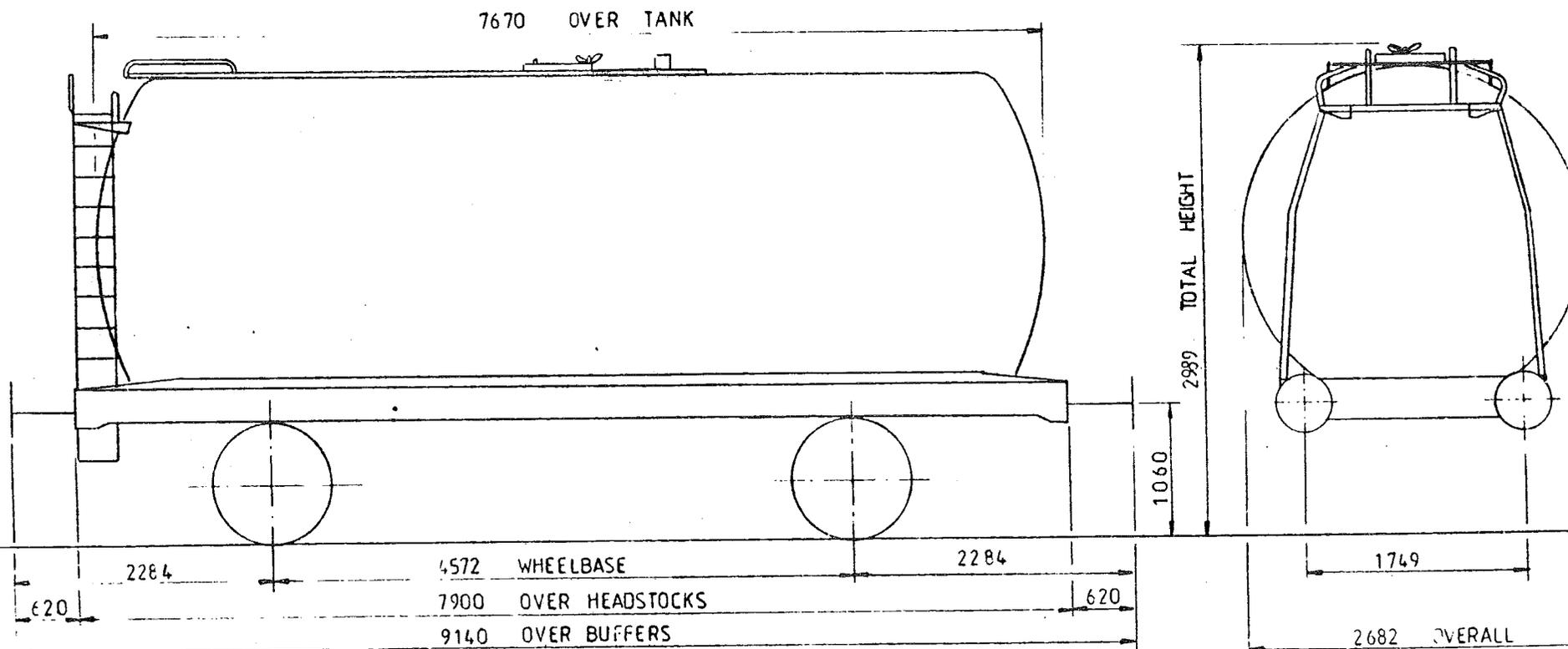

TARE	11 000 kg
CARRYING CAPACITY	35 000 kg
CAPACITY	40914 Litres
MAX SPEED	60 mile/h
WHEELS	φ 952
JOURNALS	φ140 ROLLER BEARINGS

BUFFERS	SELF CONTAINED	740 HEADS
COUPLINGS	INTERNATIONAL SCREW	
MIN CURVE	31 m	
GEN ARRGT	ORG No.	
DRARE	AIR BLOCK	HAND LEVER
SUSPENSION	FRICTION CONTROLLED PARABOLIC SPRINGS	

ISSUE 1

46 tonnes G.L.W. TANK WAGON CLASS B

TTO30E

EXCESS LENGTH	4	H	M	L	E
tonnes	46	46	12	12	
VB					
AB	22	22	8	8	
RA	8	8	1	1	
MAX SPEED	60	60	60	60	

TOPS CODE						
CARKND	AARKND	FRONT PANEL				
T	T	A	T	A	A	
						1570

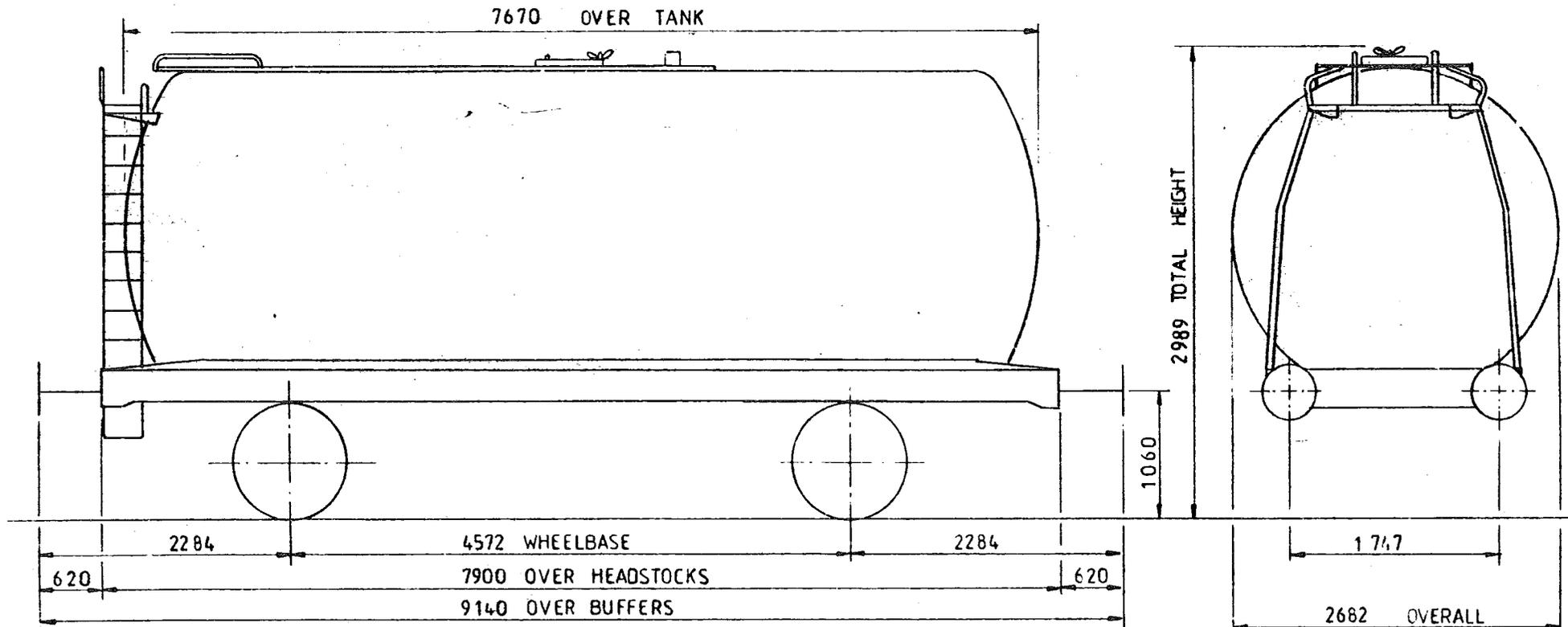

TARE	11450 kg
CARRYING CAPACITY	34500 kg
CAPACITY	40459 Litres
MAX SPEED	60 mile/h
WHEELS	φ 952
JOURNALS	φ140 ROLLER BEARINGS

BUFFERS	SELF CONTAINED,	φ406 HEADS
COUPLINGS	INTERNATIONAL SCREW	
MIN CURVE	31 m	
GEN ARRG'T DRG No		
BRAKE	AIR BLOCK	HAND LEVER
SUSPENSION	FRICTION CONTROLLED PARABOLIC SPRING	

ISSUE 1

EX PO DIAGRAM 6/141

46 tonnes G.L.W. TANK WAGON

TT030F

EXCESS LENGTH	4	H	M	L	E
tonnes	46	46	11	11	
VB					
AB	22	22	8	8	
RA	8	8	1	1	
MAX SPEED	60	60	60	60	

TOPS CODE		
CARKND	AARKND	
T	T	A A 1 5 7 0

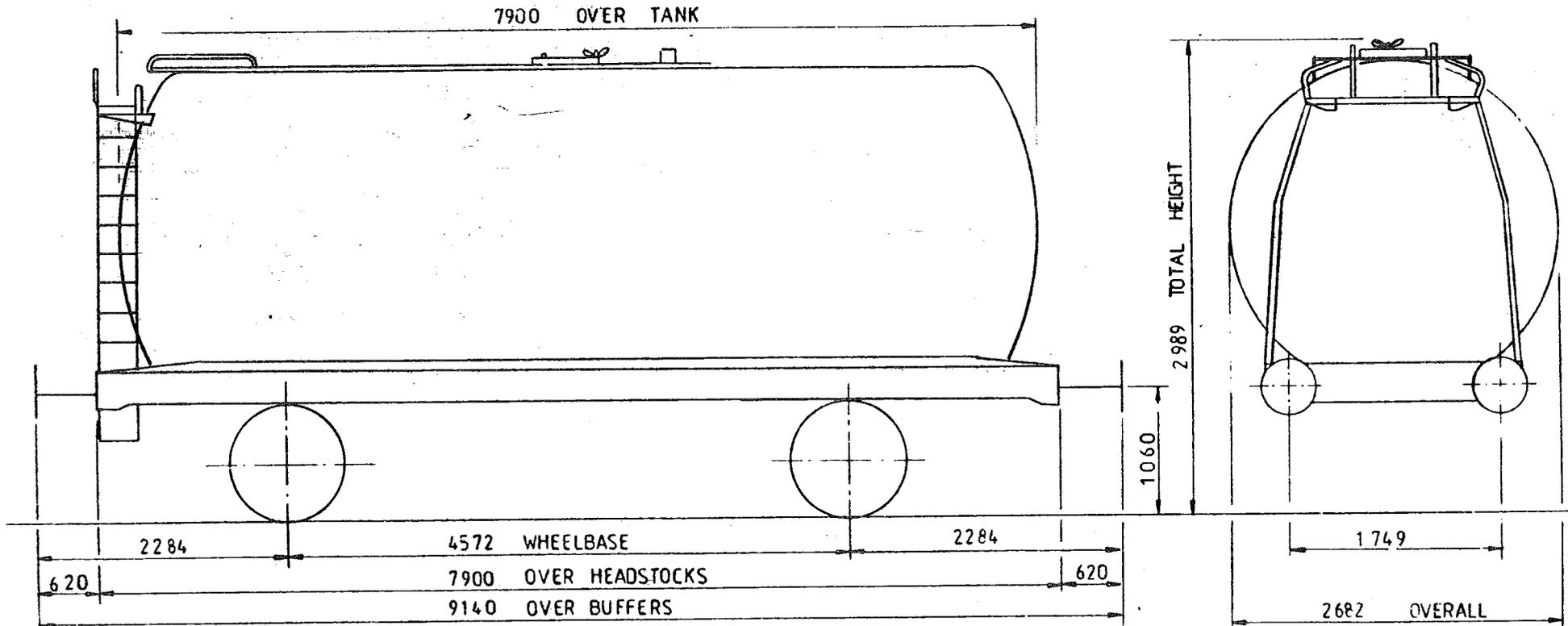

TARE	11000 kg
CARRYING CAPACITY	35000 kg
CAPACITY	41596 Litres
MAX SPEED	60 mile/h
WHEELS	φ 952
JOURNALS	φ140 ROLLER BEARINGS

BUFFERS	SELF CONTAINED, φ400 HEADS
COUPLINGS	INTERNATIONAL SCREW
MIN CURVE	31 m
GEN ARRGT DRG No	
BRAKE	AIR BLOCK HAND LEVER
SUSPENSION	FRICTION CONTROLLED PARABOLIC SPRING

ISSUE 1

EX PO DIAGRAM 6/142

46 tonnes G.L.W. TANK WAGON-CLASS A-CLOSE COUPLED

TTO31A

EXCESS LENGTH	4	H	M	L	E
tonnes	46	46	14	14	
VB					
AB	22	22	9	9	
RA	8	8	1	1	
MAX. SPEED	60	60	45	45	

TOPS CODE									
CARKND			AARKND			OPERATING PANEL No.			
T	T	A	T	A	A	1	5	4	6

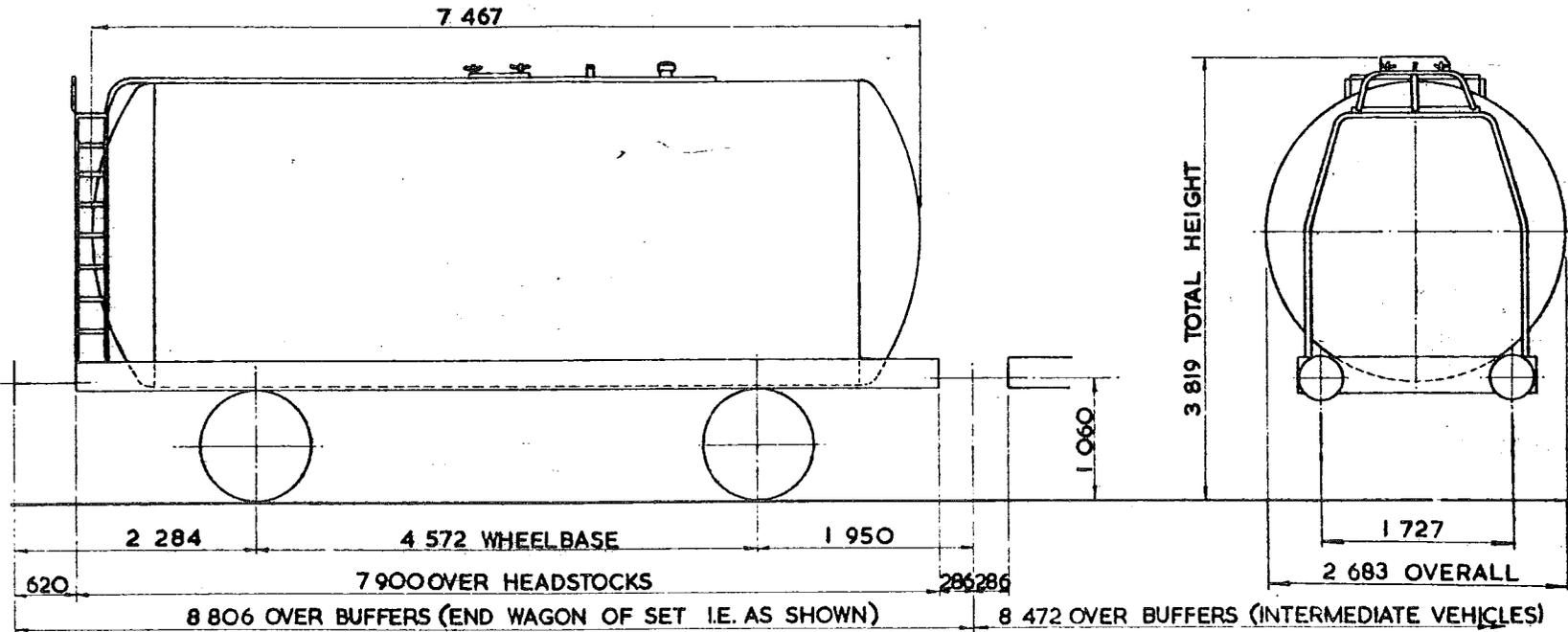

TARE - 13 450 kg
CARRYING CAPACITY - 32 500 kg
CAPACITY - 38 886 litres
MAX. SPEED - 60 mile/h
WHEELS - 952 DIA.
JOURNALS - 140 DIA. ROLLER BEARINGS

BUFFERS - HYDRAULIC 406 DIA. HEADS
COUPLINGS - INTERNATIONAL SCREW, CLOSE COUPLED
MIN. CURVE - 31m
GEN. ARRGT. DRG. No. -
BRAKE - AIR BLOCK & HAND LEVER
SUSPENSION - DOUBLE LINK

BUILDER - METRO CAMELL
OWNER - B.R.T. & E. LTD
REGISTERED BY - C.M. & E.E.(B.R.B.) DERBY
YEAR BUILT - 1967
REGISTRATION Nos. - 57747 TO 57821 (RANGE)
OWNERS Nos. - 10397 TO 10471 (RANGE)

ISSUE 2
EX P.O. DIAGRAM 6/222

46 tonnes G.L.W. TANK WAGON- CLASS B - CLOSE COUPLED

TT031D

DESIGN SHEET No. W.070

EXCESS LENGTH L	H	M	L	E
tonnes	46	46	13	13
VB				
AB	22	22	9	9
RA	8	8	1	1
MAX. SPEED	60	60	60	60

TOPS CODE							
CARKND		AARKND		OPERATING PANEL No.			
T	T	A	T	A	A	1	5
						8	8

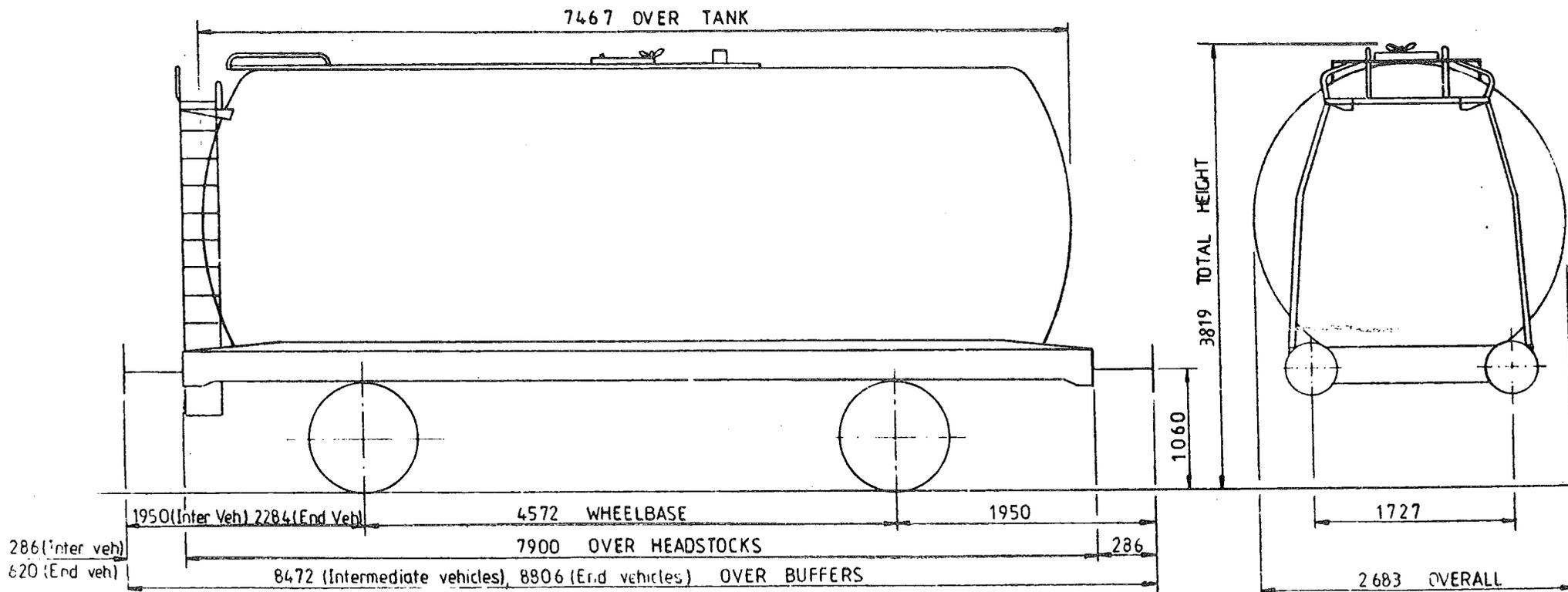

TARE -	13 500 kg
CARRYING CAPACITY -	32 500 kg
CAPACITY -	36 886 litres
MAX. SPEED -	60 mile/h
WHEEL -	Ø 952
WHEELS -	Ø140 ROLLER BEARINGS

BUFFERS -	HYDRAULIC Ø406 HEADS
COUPLINGS -	INTERNATIONAL SCREW
MIN. CURVE -	31 m
GEN. ARRGT. DRG No -	
BRAKE -	AIR, BLOCK & HAND LEVER
SUSPENSION -	FAT 26

ISSUE 2.

46 tonne GLW TANK WAGON CLASS 'B' -CLOSE COUPLED

LOT NUMBER	

TOPS INFORMATION												
AARKND	OPERATING PANEL No.			OPERATING SPEED		BRAKE FORCE DATA		EXCESS LENGTH	RA (GLW)	DESIGN SHEET		
CARKND				60 mile/h UP TO mile/h ABOVE		46 tonne GLW		9 t FORCE UP TO 22 t FORCE ABOVE	31 tonne GLW	4	8	W1288
T	T	B	A									

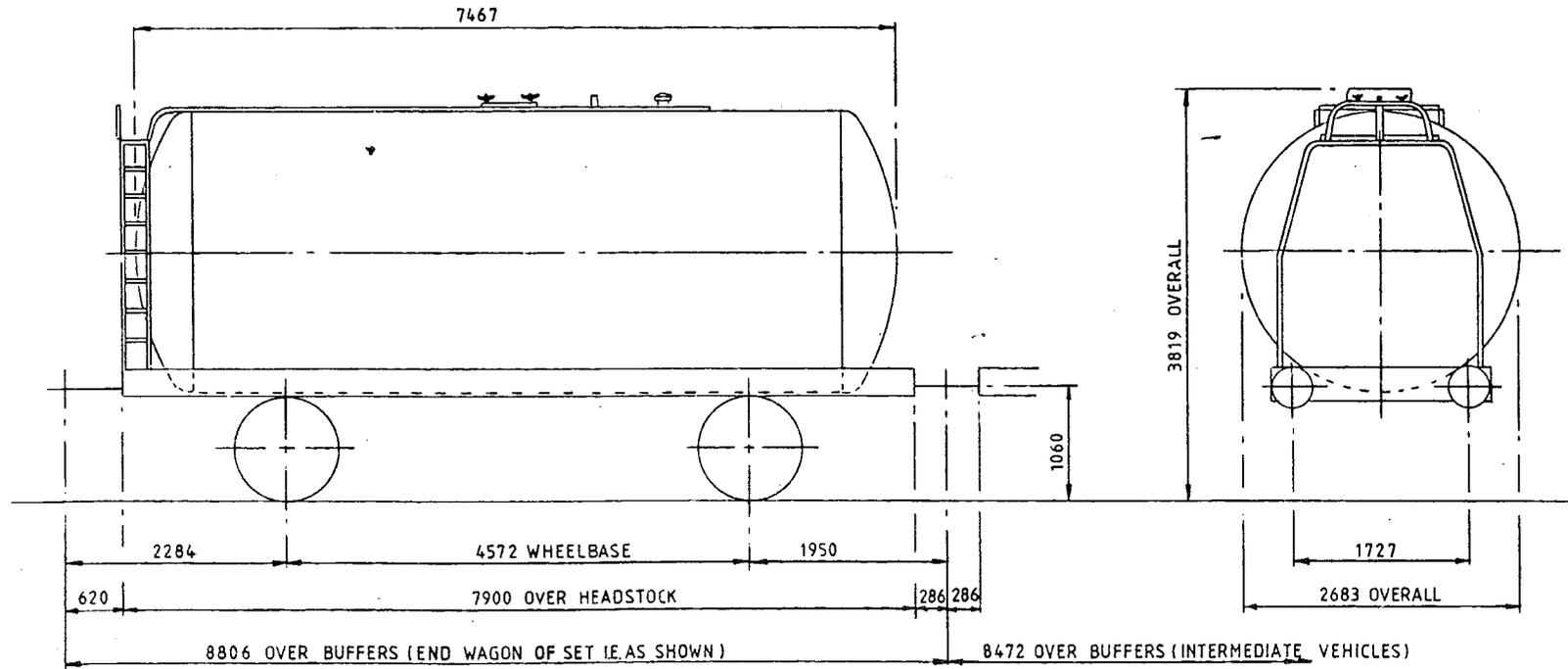

TARE-	13.000 Kg
CAPACITY, WEIGHT-	33.000 Kg
CAPACITY, VOLUME-	38.886 litres
MIN. CURVE-	31 m
GEN. ARRGT. DRG. NO.-	

BRAKE-	AIR BLOCK, VAC PIPE, HAND LEVER
SUSPENSION-	DOUBLE LINK & PARABOLIC SPRING
COUPLINGS-	INTERNATIONAL SCREW CLOSE COUPLED
BUFFERS-	HYDRAULIC 406 DIA HEADS
WHEELS-	952 DIA
JOURNALS-	140 DIA ROLLER BEARINGS

ISSUE 1

46 tonnes G.L.W. TANK WAGON

TTO32A

EXCESS LENGTH	5	H	M	L	E
tonnes	46	46	14	14	
VB	17	17	7	7	
AB					
RA	8	8	1	1	
MAX. SPEED	60	60	45	45	

TOPS CODE										
CARKND		AARKND		TOPS PARTIAL PANEL No.						
T	T	F	T	T	F	A	I	5	4	9

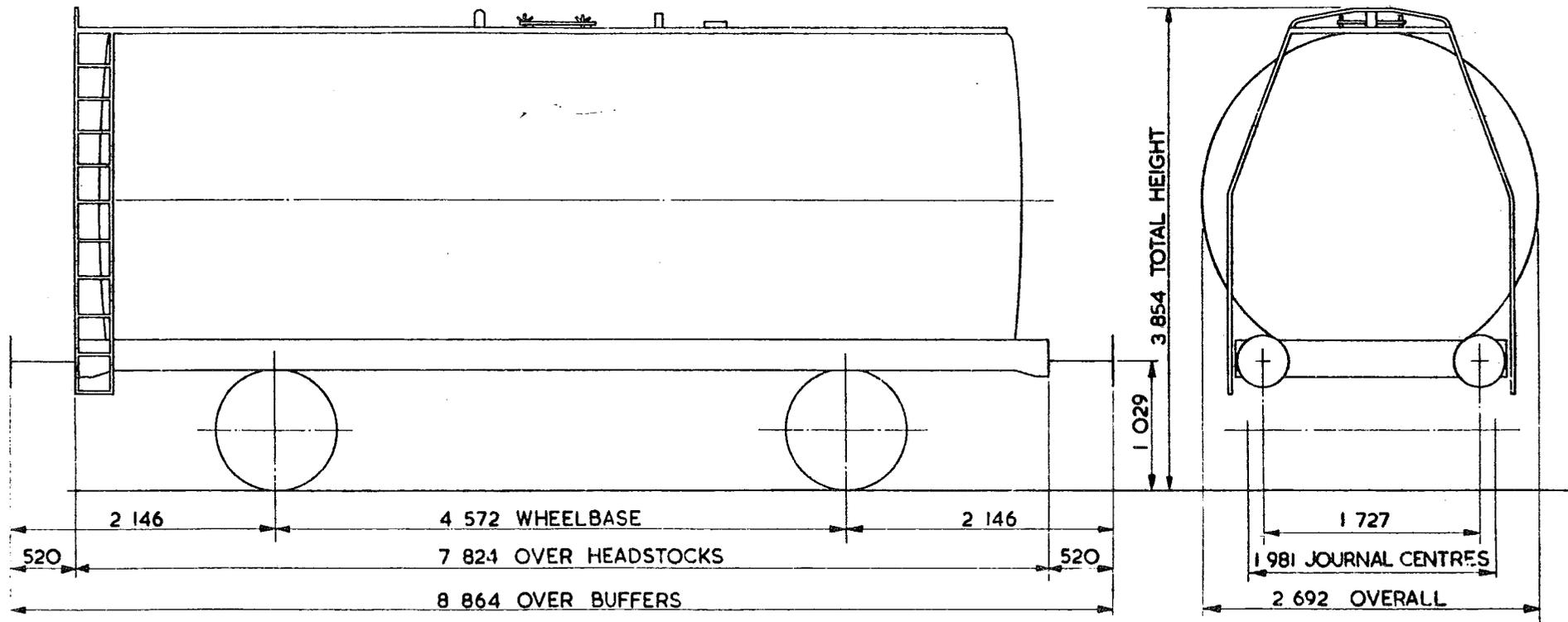

TARE - 13450 kg
CARRYING CAPACITY - 32500 kg
CAPACITY - 39761 litres.
MAX. SPEED - 60 mile/h
WHEELS - 952 DIA.
JOURNALS - 140 DIA. ROLLER BEARINGS

BUFFERS - HYDRAULIC 406 DIA. HEADS
COUPLINGS INSTANTER
MIN CURVE 31 m
GEN. ARRGT. DRG. No. -
BRAKE - VACUUM BLOCK & HAND LEVER
SUSPENSION - DOUBLE LINK

BUILDER METRO-CAMMELL
OWNER - STORAGE & TRANSPORT SYSTEM LTD
REGISTERED BY - C.M. & E.E. (B.R.B.) DERBY
YEAR BUILT - 1965
REGISTRATION Nos. 53062-53081, 53089-53091
OWNERS Nos. - 62-91

ISSUE 2

EX. P.O. DIAGRAM 6/746 (ALLOCATED)

46 tonnes G.L.W. TANK WAGON - CLASS A

TTO32B

EXCESS LENGTH	5	H	M	L	E
tonnes	46	46	14	14	
VB	0	0	0	0	
AB	26	26	10	10	
RA	8	8	1	1	
MAX. SPEED	60	60	45	45	

TOPS CODE										
CARKND			AARKND			OPERATING PANEL No				
T	T	B	T	T	B	A	1	3	2	9

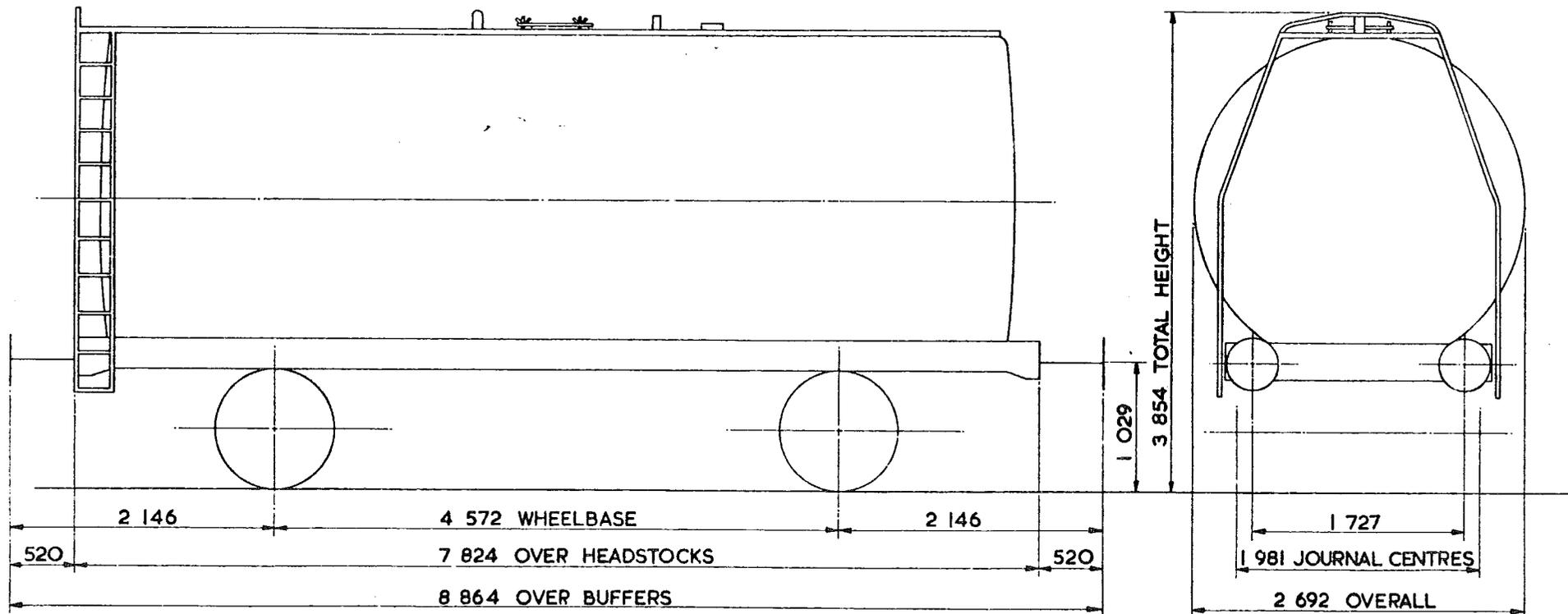

TARE -	13 450 kg
CARRYING CAPACITY-	32 500 kg
CAPACITY-	39 761 litres.
MAX SPEED -	60 mile/h
WHEELS -	952 DIA.
JOURNALS -	140 DIA. ROLLER BEARINGS

BUFFERS -	HYDRAULIC 406 DIA. HEADS
COUPLINGS -	INSTANTER
MIN CURVE -	31 m
GEN. ARRGT. DRG. No. -	
BRAKE -	AIR BLOCK, VACUUM PIPED & HAND LEVER
SUSPENSION -	DOUBLE LINK

BUILDER -	METRO - CAMELL
OWNER -	STORAGE & TRANSPORT SYSTEM LTD.
REGISTERED BY -	C.M. & E.E. (B.R.B) DERBY
YEAR BUILT -	1965
REGISTRATION Nos. -	53082 - 53088
OWNERS Nos. -	

ISSUE 2
EX. PO. DIAGRAM 6/349

46 tonne GLW TANK WAGON - CLASS A

LOT NUMBER	

TOPS INFORMATION										
AARKND	OPERATING PANEL No.			OPERATING SPEED		BRAKE FORCE DATA		EXCESS LENGTH	RA (GLW)	DESIGN SHEET
CARKND				60 mile/h UP TO	46 tonne GLW	10t FORCE UP TO	31 tonne GLW	4	8	WI493
T T A A				mile/h ABOVE		26t FORCE ABOVE				

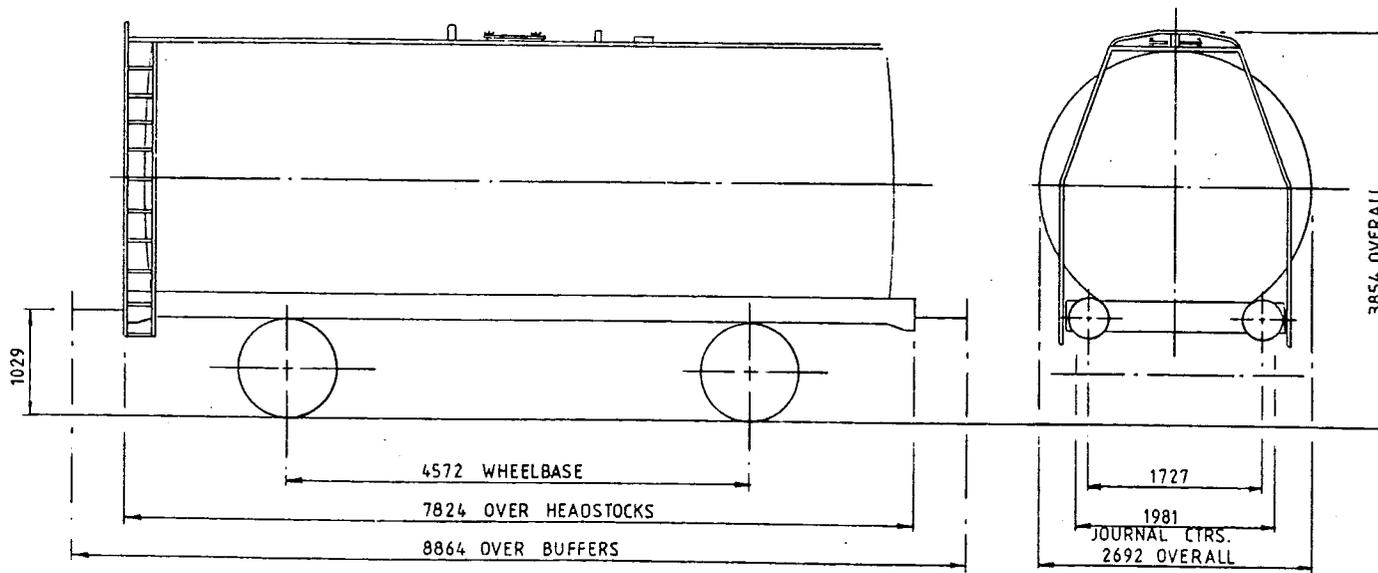

TARE-	13,800 Kg
CAPACITY, WEIGHT-	32,200 Kg
CAPACITY, VOLUME-	39,761 litres
MIN. CURVE-	31 m
GEN. ARRGT. DRG. NO.-	

BRAKE-	AIR BLOCK & HAND LEVER
SUSPENSION-	DOUBLE LINK & PARABOLIC SPRING
COUPLINGS-	INSTANTER
BUFFERS-	HYDRAULIC 406 DIA HEADS
WHEELS-	952 DIA
JOURNALS-	140 DIA ROLLER BEARINGS

ISSUE 1

46 tonnes G.L.W. TANK WAGON

TTO33A

EXCESS LENGTH	5	H	M	L	E
tonnes	46	46	14	14	
VB	20	20	8	8	
AB					
RA	6	6	1	1	
MAX SPEED	60	60	45	45	

TOPS CODE									
CARKND	AARKND		T T V T T V A I S S O						

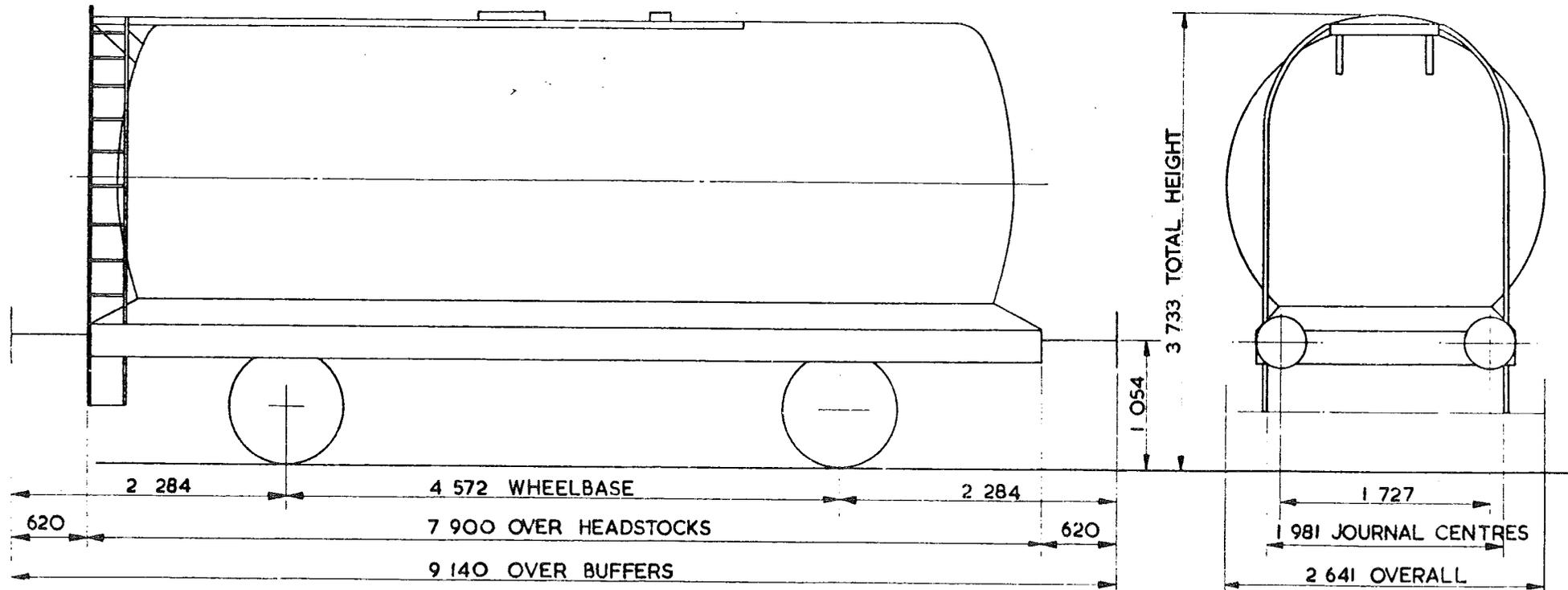

TARE - 13 250 kg
CARRYING CAPACITY - 32 700 kg
CAPACITY - 39 550 litres
MAX. SPEED - 60 mile/h
WHEELS - 952 DIA.
JOURNALS - 140 DIA. ROLLER BEARINGS

BUFFERS - HYDRAULIC 406 DIA. HEADS
COUPLINGS - B.R. SCREW
MIN. CURVE - 31 m
GEN. ARRGT DRG No.
BRAKE - VACUUM BLOCK & HAND LEVER
SUSPENSION - EYEBOLT

BUILDER - CHARLES ROBERTS
OWNER - TIGER RAILCAR LEASING
REGISTERED BY - C.M. & E.E. (B.R.B.) DERBY
YEAR BUILT - 1964
REGISTRATION Nos. - 51539 TO 51547
OWNERS Nos. - A539 TO A547

ISSUE 2
EX. P.O. DIAGRAM 6/762 (ALLOCATED)

46 tonnes GL.W. TANK WAGON

TTO33B

EXCESS LENGTH	5	H	M	L	E
tonnes	46	46	14	14	
VB	20	20	8	8	
AB					
RA	6	6	1	1	
MAX. SPEED	60	60	45	45	

TOPS CODE										
CARKND	AARKND									
T	T	V	T	T	V	A	1	5	5	0

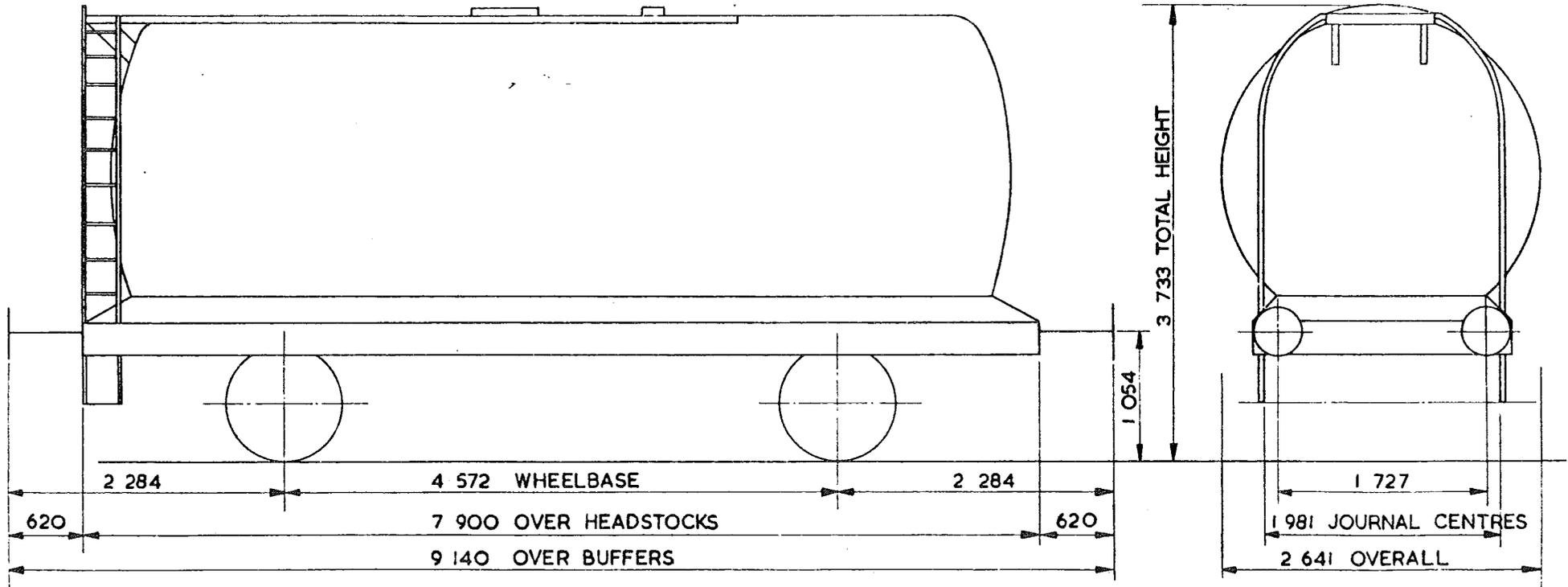

TARE - 13 250 kg
CARRYING CAPACITY - 32 700 kg
CAPACITY - 39 550 litres
MAX SPEED - 60 mile/h
WHEELS - 952 DIA.
JOURNALS - 140 DIA. ROLLER BEARINGS.

BUFFERS - HYDRAULIC 406 DIA. HEADS
COUPLINGS B.R. SCREW
MIN CURVE 31m
GEN ARRGT DRG No
BRAKE VACUUM BLOCK & HAND LEVER
SUSPENSION EYEBOLT & AUXILIARY RUBBERS

BUILDER - CHARLES ROBERTS
OWNER TIGER RAILCAR LEASING
REGISTERED BY C.M. & E.E. (B.R.B.) DERBY
YEAR BUILT - 1963
REGISTRATION No. 51549 - 51560
OWNERS Nos - A549 - A560

ISSUE 2
EX. P.O. DIAGRAM 6/763 (ALLOCATED)

46 tonne GLW TANK WAGON - CLASS A

LOT NUMBER	

TOPS INFORMATION										
AARKND		OPERATING		OPERATING SPEED		BRAKE FORCE DATA		EXCESS LENGTH	RA (GLW)	DESIGN SHEET
CARKND		PANEL No.		60 mile/h UP TO		5 t FORCE UP TO		5	9	W1492
T T A A				mile/h ABOVE 46 tonne GLW		24 t FORCE ABOVE 30.5 tonne GLW				

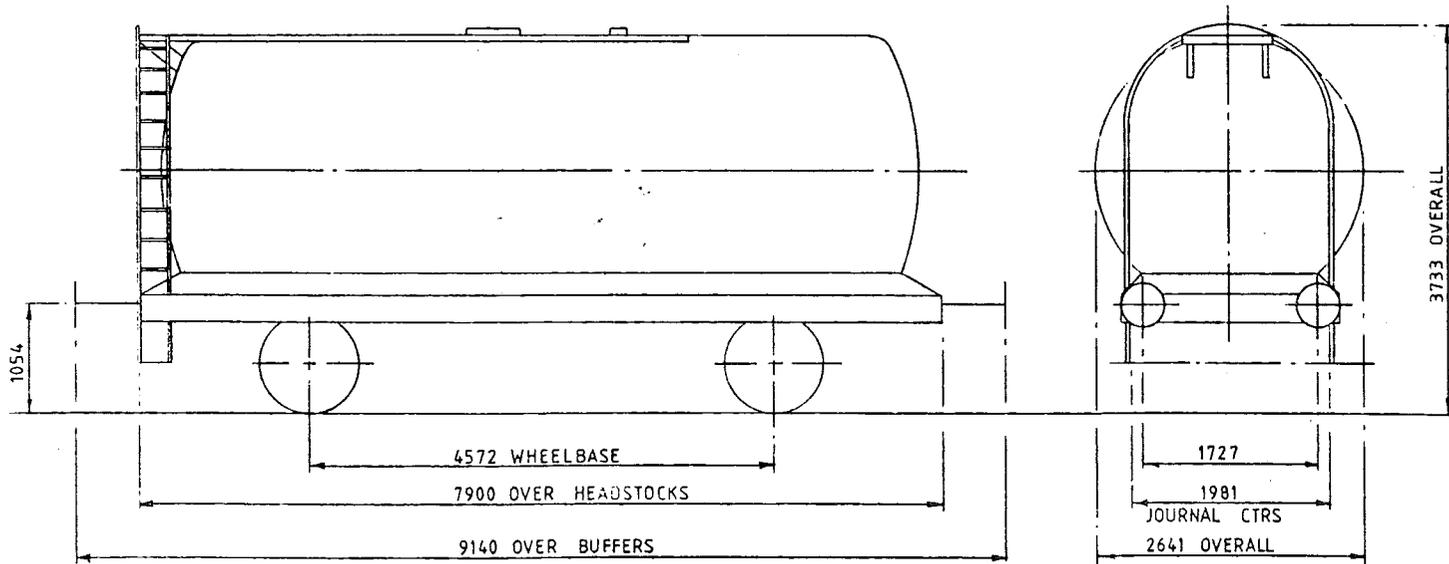

TARE-	12.700 Kg
CAPACITY, WEIGHT-	33.300 Kg
CAPACITY, VOLUME-	39.550 litres
MIN. CURVE-	31m
GEN. ARRGT. DRG. NO.-	

BRAKE-	AIR BLOCK & HAND LEVER
SUSPENSION-	DOUBLE LINK & PARABOLIC SPRING
COUPLINGS-	B.R. SCREW
BUFFERS-	HYDRAULIC 406 DIA HEADS
WHEELS-	952 DIA
JOURNALS-	140 DIA ROLLER BEARINGS

ISSUE 1

46 tonnes G.L.W. TANK WAGON.

TTO34A

EXCESS LENGTH	4	H	M	L	E
tonnes.	46	46	14	14	
VB	17	17	8	8	
AB					
RA	8	8	1	1	
MAX. SPEED	60	60	45	45	

TOPS CODE										
CARKND			AARKND			OPERATING PANEL No				
T	T	V	T	T	V	A	1	5	0	3

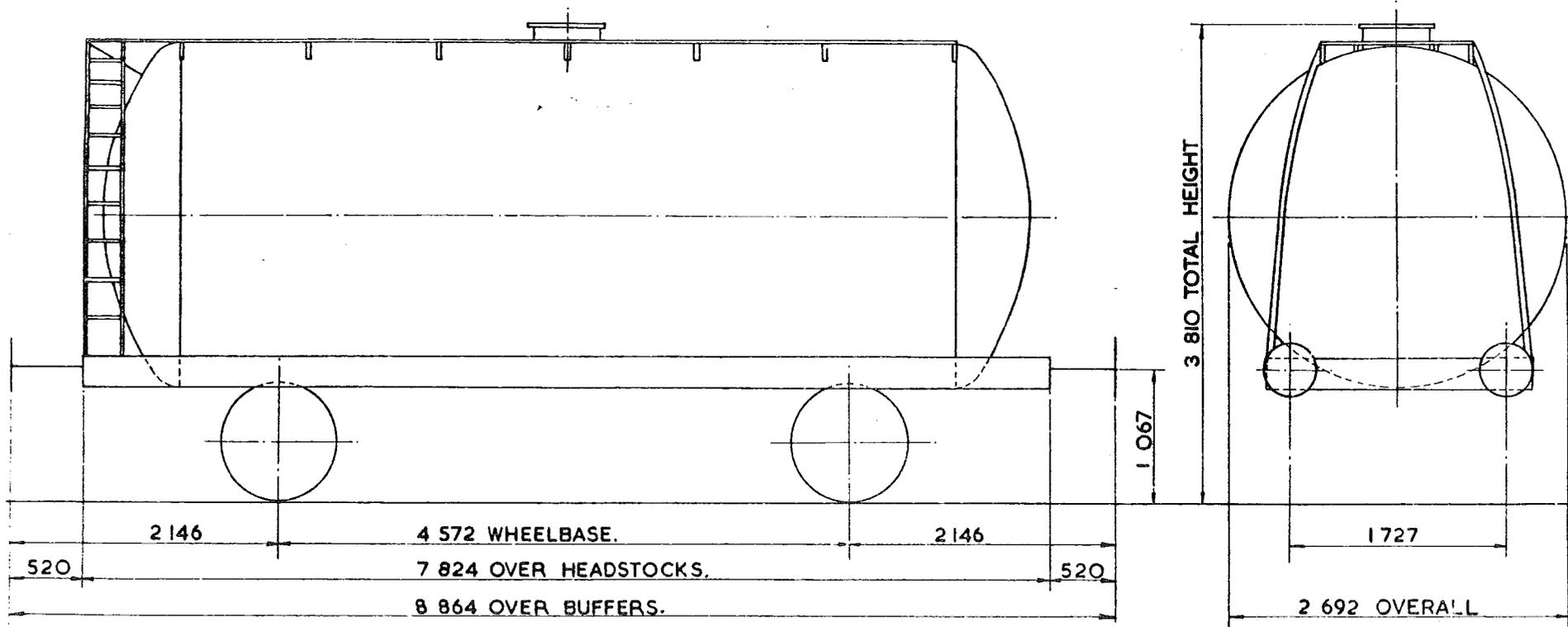

TARE - 13 500 kg
CARRYING CAPACITY - 32 500 kg
CAPACITY - 38 736 litres
MAX SPEED - 60 mile/h
WHEELS - 952 DIA.
JOURNALS - 140 DIA. ROLLER BEARINGS.

BUFFERS - HYDRAULIC 406 DIA. HEADS
COUPLINGS - INSTANTER
MIN. CURVE - 31m.
GEN. ARRGT. DRG. No. -
BRAKE - VACUUM BLOCK & HAND LEVER
SUSPENSION - DOUBLE LINK.

BUILDER - CHARLES ROBERTS & CO. LTD.
OWNER - SUKO & BPO
REGISTERED BY - C.M. & E.E. (B.R.B.) DERBY.
YEAR BUILT - 1965
REGISTRATION Nos. - SUKO 60120 TO 60259 (RANGE) BPO 60176 TO 60298 (RANGE)
OWNERS Nos. -

ISSUE 2

EX. PO. DIAGRAM 6/804 (ALLOCATED).

46 tonnes G.L.W. TANK WAGON.

TTO34B

EXCESS LENGTH	4	H	M	L	E
tonnes.	46	46	14	14	
VB	18	18	7	7	
AB					
RA	8	8	1	1	
MAX. SPEED	60	60	45	45	

TOPS CODE									
CARKND		AARKND			OPERATING PANEL No				
T	T	F	T	T	F	A	I	5	O

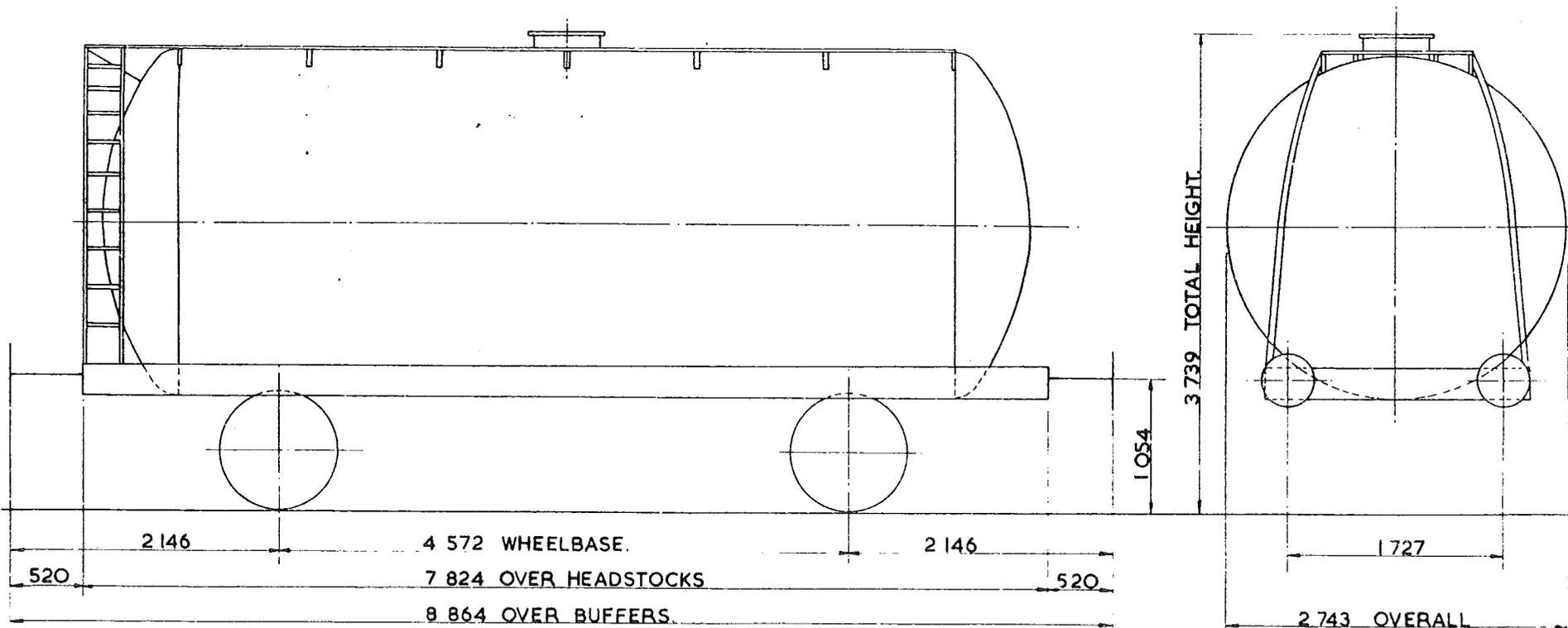

TARE --	13450kg.
CARRYING CAPACITY--	32500kg.
CAPACITY--	39491 litres.
MAX. SPEED --	60 mile/h
WHEELS --	952 DIA.
JOURNALS -	140 DIA. ROLLER BEARINGS

BUFFERS --	HYDRAULIC 406 DIA. HEADS
COUPLINGS	INSTANTER
MIN CURVE	31m
GEN ARRGT DRG No.	
BRAKE -	VACUUM BLOCK & HAND LEVER
SUSPENSION	DOUBLE LINK

BUILDER--	CHARLES ROBERTS
OWNER --	SUKO & BPO
REGISTERED BY--	C.M.&E.E. (B.R.B.) DERBY
YEAR BUILT--	1966
REGISTRATION Nos --	SUKO 66319 TO 66351 BPO 66370 TO 66390
OWNERS Nos. --	

ISSUE 2

EX. P.O. DIAGRAM 6/723 (ALLOCATED)

46 tonnes G.L.W. TANK WAGON

TTO34C

EXCESS LENGTH	4	H	M	L	E
tonnes	46	46	14	14	
VB	18	18	8	8	
AB					
RA	8	8	1	1	
MAX. SPEED	60	60	45	45	

TOPS CODE			
CARKND	AARKND	OPERATING PANEL No	
T	T	F	T T F A I 5 0 4

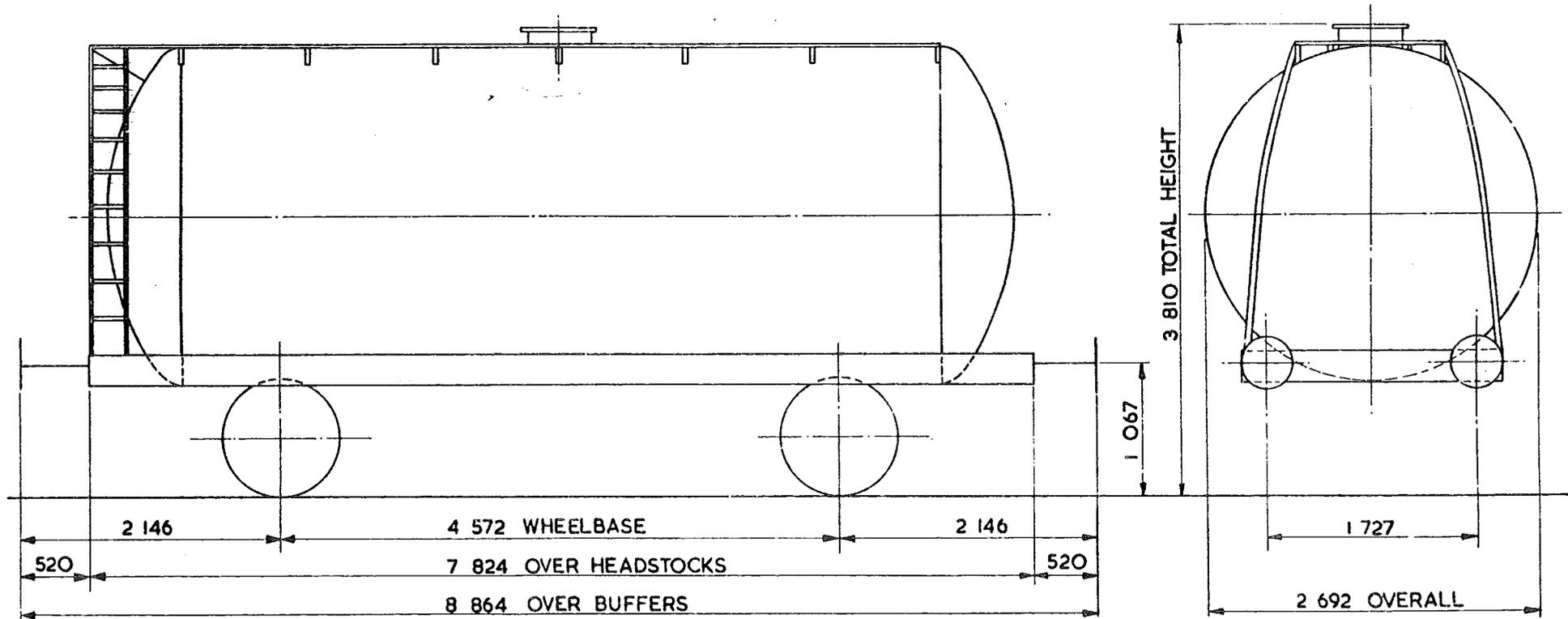

TARE --	13 500 kg
CARRYING CAPACITY --	32 500 kg
CAPACITY --	38 736 litres
MAX. SPEED --	60 mile/h
WHEELS --	952 DIA.
JOURNALS --	140 DIA. ROLLER BEARINGS

BUFFERS --	HYDRAULIC 406 DIA. HEADS
COUPLINGS --	INSTANTER
MIN. CURVE --	31m
GEN ARRGT DRG No --	
BRAKE --	VACUUM BLOCK & HAND LEVER
SUSPENSION --	DOUBLE LINK

BUILDER --	CHARLES ROBERTS
OWNER --	SUKO & BPO
REGISTERED BY --	CM.&E.E. (BR.B.) DERBY
YEAR BUILT --	1964
REGISTRATION Nos. --	SUKO 60101 TO 68254 (RANGE) BPO 60171 TO 68366 (RANGE)
OWNERS Nos. --	

ISSUE 2

EX. P.O. DIAGRAM 6/717 (ALLOCATED)

46 tonnes G.L.W. TANK WAGON - CLASS 'A'

TT034F

EXCESS LENGTH	4	H	M	L	E
tonnes	46	46	13	13	
VB					
AB	25	25	9	9	
BA	8	8	1	1	
MAX SPEED	60	60	60	60	

TOPS CODE									
CARKND		AARKND			OPERATION PAGE N				
T	T	A	T	A	A	1	5	9	3

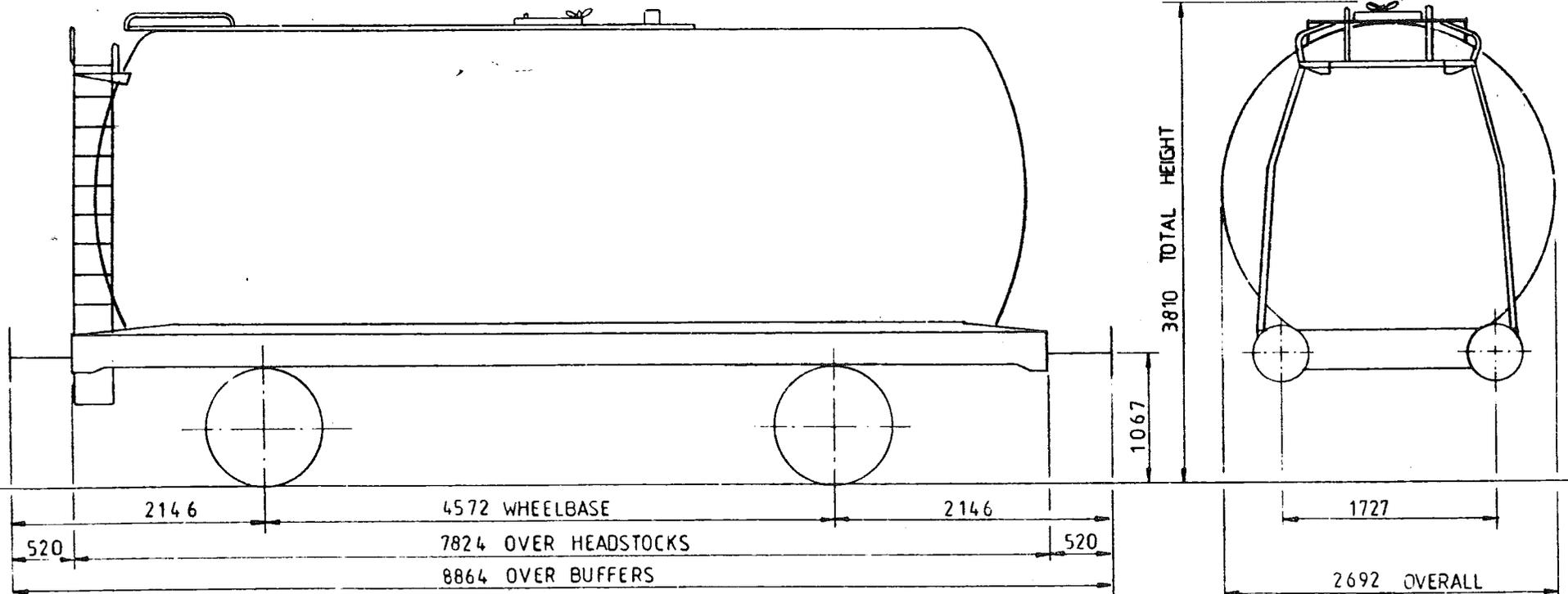

TARE	12 ⁰⁵⁰ kg
CARRYING CAPACITY -	33000 kg
CAPACITY -	38736 Litres
MAX SPEED	60 mile/h
WHEELS	φ 952
JOURNALS	φ140 ROLLER BEARINGS

BUFFERS	HYDRAULIC φ406 HEADS
COUPLINGS	INSTANTER
MIN CURVE	31 m
GEN ARRGT DRG No	
BRAKE	AIR BLOCK HAND LEVER
SUSPENSION	PARABOLIC SHORT LINK

ISSUE 1

EX PO DIAGRAM 5/1717 (ALLOCATED)

46 tonne GLW TANK WAGON - CLASS 'A'

LOT NUMBER	

TOPS INFORMATION											
AARKND		OPERATING		OPERATING SPEED			BRAKE FORCE DATA		EXCESS LENGTH	RA (GLW)	DESIGN SHEET
CARKND		PANEL No.		60 mile/h UP TO 46 tonne GLW			6t FORCE UP TO 31 tonne GLW		4	9	W1195
T	T	A	A								

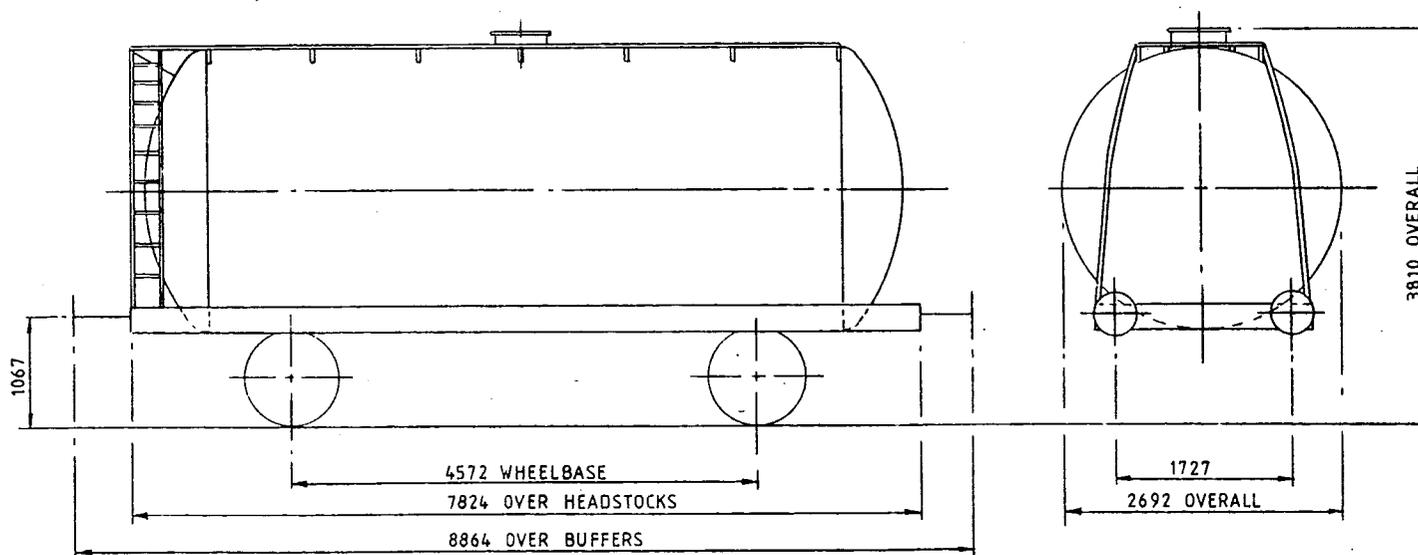

TARE-	12.550 Kg
CAPACITY, WEIGHT-	33.450 Kg
CAPACITY, VOLUME-	38.736 litres
MIN. CURVE-	31 m
GEN. ARRGT. DRG. NO.-	

BRAKE-	AIR BLOCK & HAND LEVER
SUSPENSION-	DOUBLE LINK & PARABOLIC SPRING
COUPLINGS-	INSTANTER
BUFFERS-	HYDRAULIC 406 DIA HEADS
WHEELS-	952 DIA
JOURNALS-	140 DIA ROLLER BEARINGS

ISSUE 1

46 tonne GLW TANK WAGON - CLASS 'A'

LOT NUMBER	

TOPS INFORMATION						
AARKND	OPERATING	OPERATING SPEED		BRAKE FORCE DATA		EXCESS
CARKND	PANEL No.	60 mile/h UP TO	46 tonne GLW	6t FORCE UP TO	31 tonne GLW	LENGTH
T T A A		60 mile/h ABOVE		25 t FORCE ABOVE		4
						RA (GLW)
						9
						DESIGN SHEET
						W1196

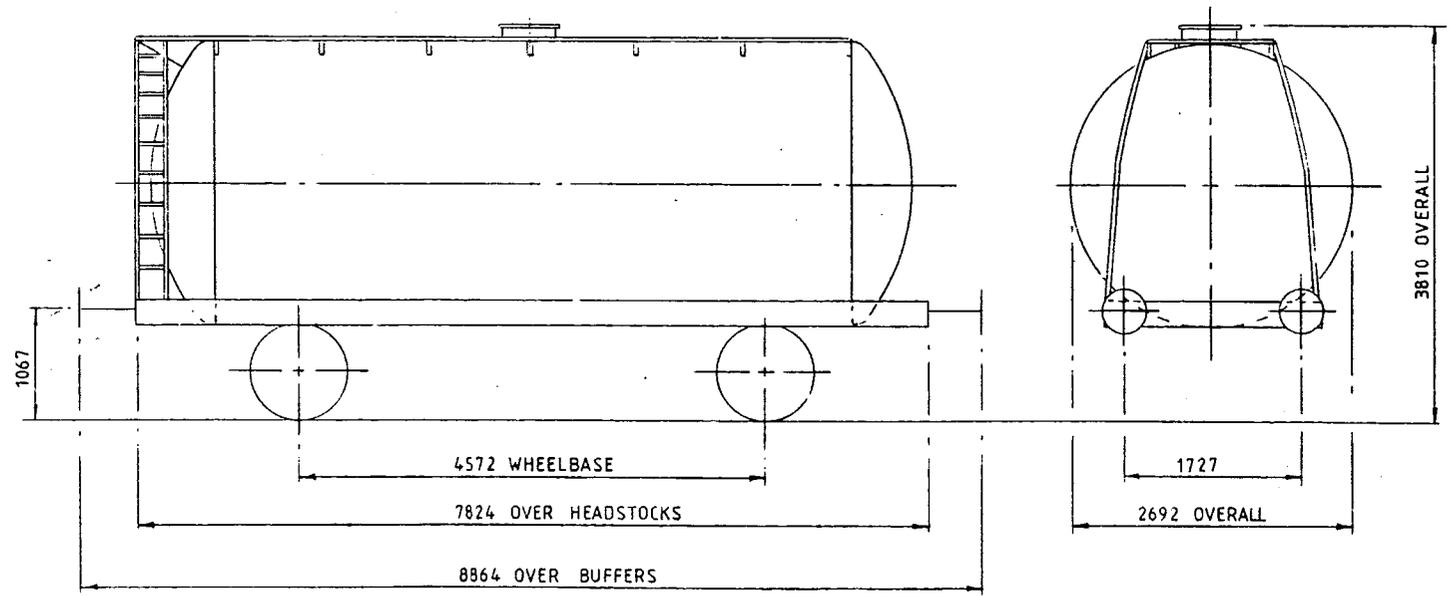

TARE-	12,600 Kg
CAPACITY, WEIGHT-	33,400 Kg
CAPACITY, VOLUME-	38,736 litres
MIN. CURVE-	31 m
GEN. ARRGT. DRG. NO.-	

BRAKE-	AIR BLOCK & HAND LEVER
SUSPENSION-	DOUBLE LINK & PARABOLIC SPRING
COUPLINGS-	INSTANTER
BUFFERS-	HYDRAULIC 406 DIA HEADS
WHEELS-	952 DIA
JOURNALS-	140 DIA ROLLER BEARINGS

ISSUE 1

46 tonne GLW TANK WAGON

LOT NUMBER	

TOPS INFORMATION												
AARKND		OPERATING		OPERATING SPEED			BRAKE FORCE DATA			EXCESS LENGTH	RA (GLW)	DESIGN SHEET
CARKND		PANEL No.		60 mile/h UP TO			5t FORCE UP TO			4	9	WI296
T T A A				mile/h ABOVE			46 tonne GLW			30.5 tonne GLW		

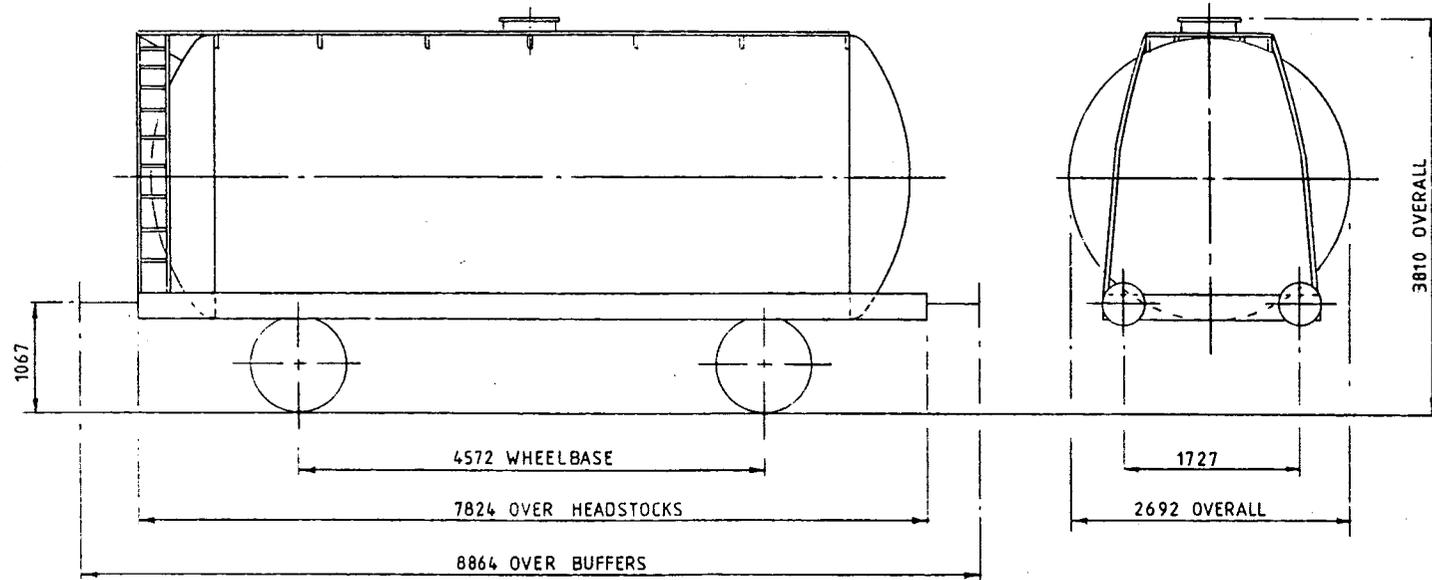

TARE-	12,800 Kg
CAPACITY, WEIGHT-	33,200 Kg
CAPACITY, VOLUME-	38,736 litres
MIN. CURVE-	31 m
GEN. ARRGT. DRG. NO.-	

BRAKE-	AIR BLOCK & HAND LEVER
SUSPENSION-	DOUBLE LINK & PARABOLIC SPRING
COUPLINGS-	INSTANTER
BUFFERS-	HYDRAULIC 406 DIA HEADS
WHEELS-	952 DIA
JOURNALS-	140 DIA ROLLER BEARINGS

ISSUE 1

46 tonne GLW TANK WAGON

LOT NUMBER	

TOPS INFORMATION										
AARKND		OPERATING		OPERATING SPEED		BRAKE FORCE DATA		EXCESS LENGTH	RA (GLW)	DESIGN SHEET
CARKND		PANEL No.		60 mile/h UP TO 46 tonne GLW		5t FORCE UP TO 30 tonne GLW		4	8	WI277
T	T	A	A							

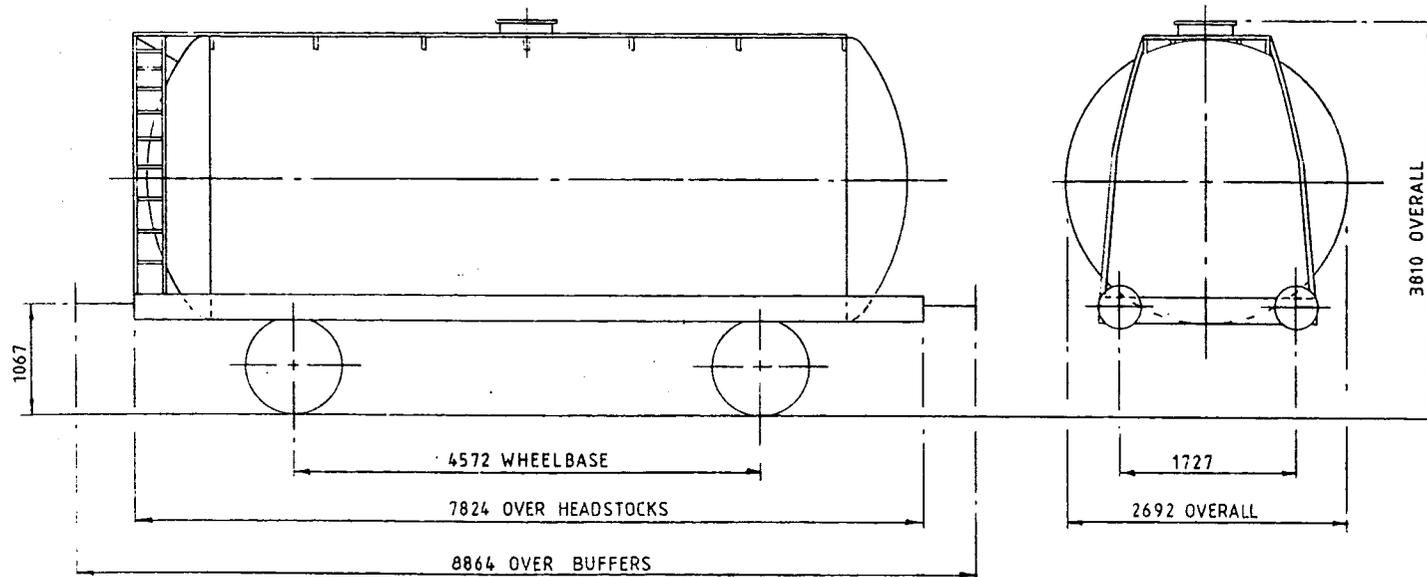

TARE-	13.200 Kg
CAPACITY, WEIGHT-	32.800 Kg
CAPACITY, VOLUME-	38.736 litres
MIN. CURVE-	31 m
GEN. ARRGT. DRG. NO.-	

BRAKE-	AIR BLOCK & HAND LEVER
SUSPENSION-	DOUBLE LINK & PARABOLIC SPRING
COUPLINGS-	INSTANTER
BUFFERS-	HYDRAULIC 406 DIA HEADS
WHEELS-	952 DIA
JOURNALS-	140 DIA ROLLER BEARINGS

ISSUE 1

46 tonne GLW TANK WAGON-CLASS 'B'

LOT NUMBER	

TOPS INFORMATION						
AARKND	OPERATING		OPERATING SPEED		BRAKE FORCE DATA	
CARKND	PANEL No.		60 mile/h UP TO 46 tonne GLW		5t FORCE UP TO 30.5tonne GLW	
T T A A			mile/h ABOVE		24t FORCE ABOVE	
					EXCESS LENGTH	RA (GLW)
					4	9
						DESIGN SHEET
						WI353

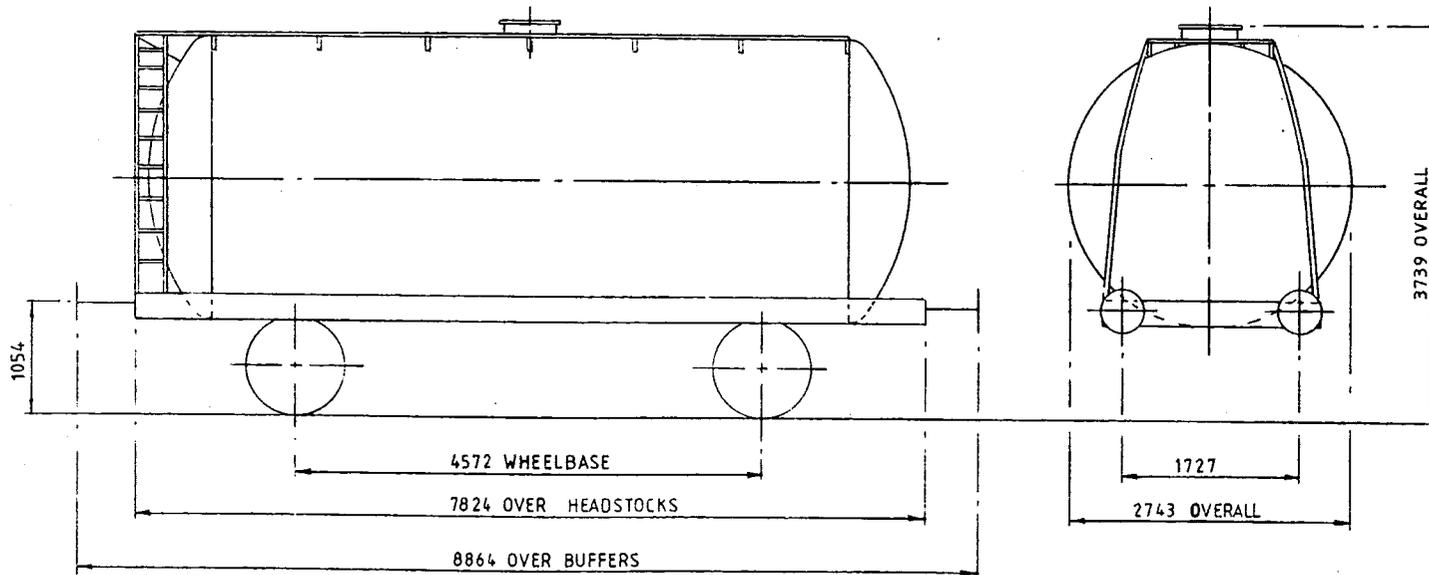

TARE-	12,700 Kg
CAPACITY, WEIGHT-	33,300 Kg
CAPACITY, VOLUME-	39.491 litres
MIN. CURVE-	31m
GEN. ARRGT. DRG. NO.-	

BRAKE-	AIR BLOCK & HAND LEVER
SUSPENSION-	DOUBLE LINK & PARABOLIC SPRING
COUPLINGS-	INSTANTER
BUFFERS-	HYDRAULIC 406 DIA HEADS
WHEELS-	952 DIA
JOURNALS-	140 DIA ROLLER BEARINGS

ISSUE 1

46 tonne GLW TANK WAGON (GREASE)

LOT NUMBER	

TOPS INFORMATION							
AARKND	OPERATING	OPERATING SPEED		BRAKE FORCE DATA	EXCESS LENGTH	RA (GLW)	DESIGN SHEET
CARKND	PANEL No.	45 mile/h UP TO	13.5 tonne GLW	7t FORCE UP TO	31 tonne GLW	4	W1375
T T G A		60 mile/h ABOVE		18t FORCE ABOVE		8	

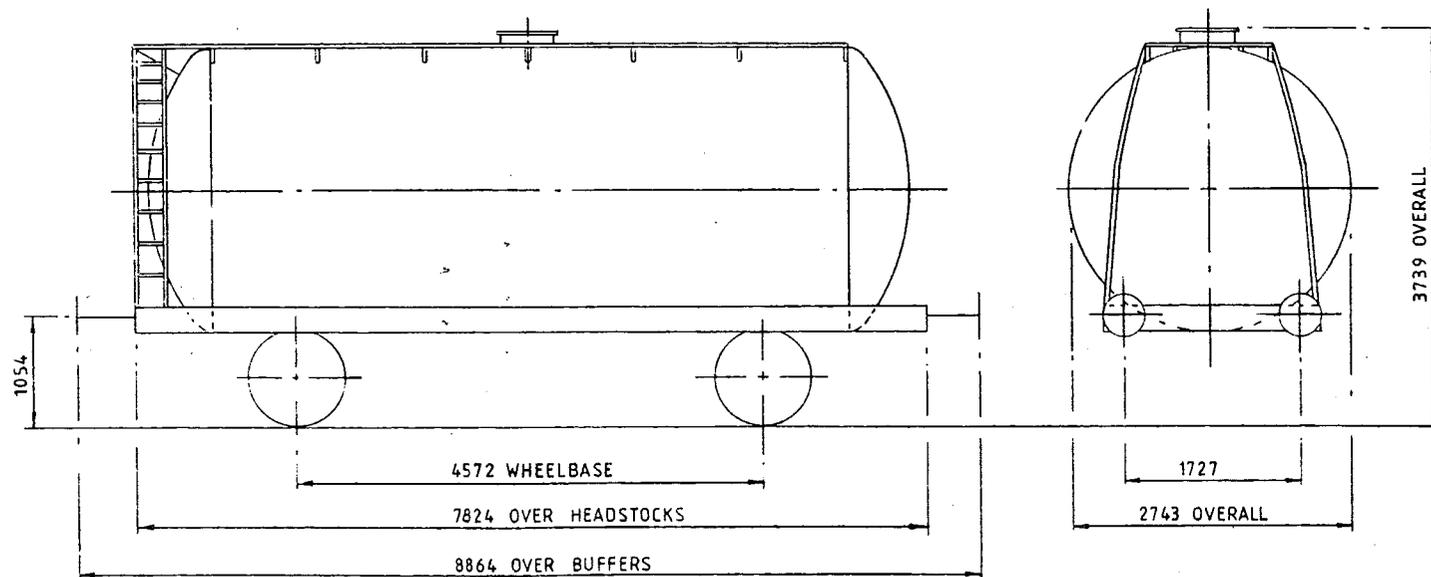

TARE-	13,450 Kg
CAPACITY, WEIGHT-	32,500 Kg
CAPACITY, VOLUME-	39.49 litres
MIN. CURVE-	31 m
GEN. ARRGT. DRG. NO.-	

BRAKE-	VAC. BLOCK, AIR PIPED, HAND LEVER
SUSPENSION-	DOUBLE LINK
COUPLINGS-	INSTANTER
BUFFERS-	HYDRAULIC 406 DIA HEADS
WHEELS-	952 DIA
JOURNALS-	140 DIA ROLLER BEARINGS

ISSUE 1

46 tonnes G.L.W. TANK WAGON - CLASS B - COILED

TTO35A

EXCESS LENGTH	5	H	M	L	E
tonnes	46	46	15	15	
VB	19	19	8	8	
AB					
RA	8	8	1	1	
MAX SPEED	60	60	45	45	

TOPS CODE										
CARKND	AARKND			OPERATING PANEL No.						
T	T	F	T	T	F	A	1	5	2	1

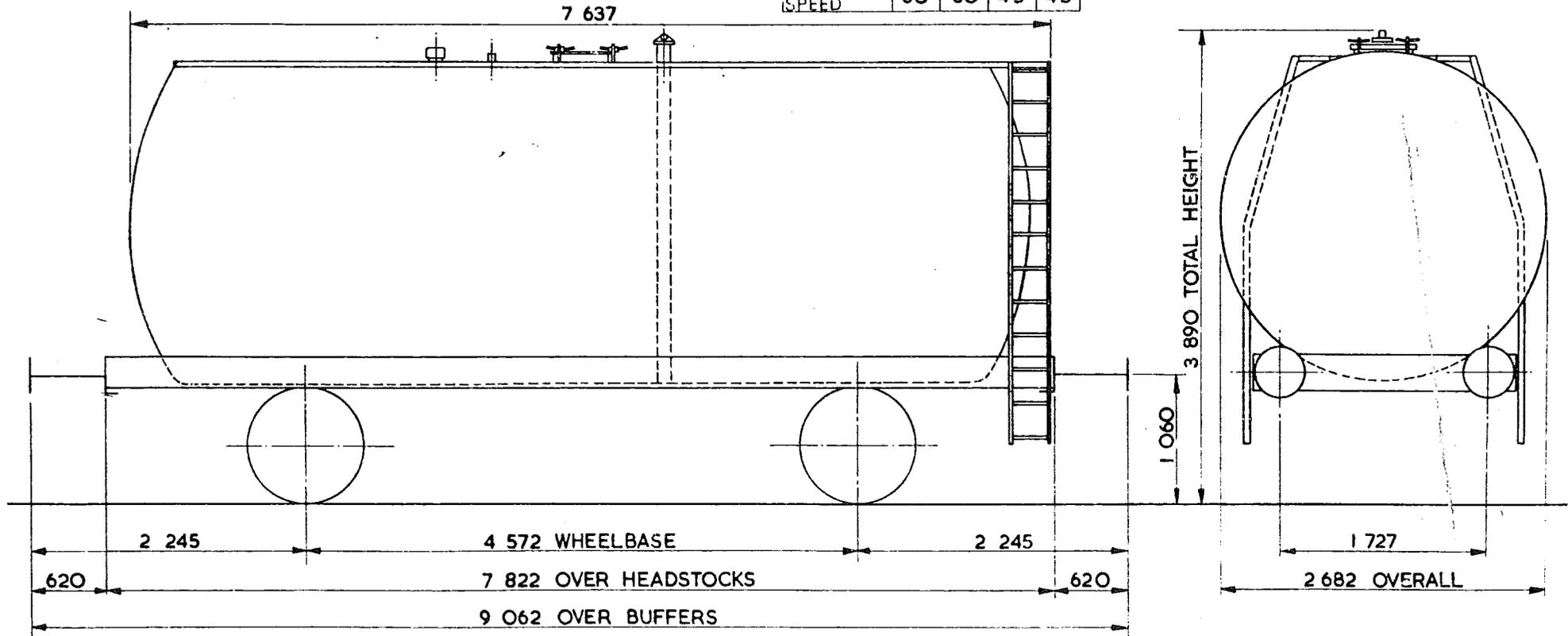

TARE -	14 550 kg
CARRYING CAPACITY -	31 400 kg
CAPACITY -	39 296 litres
MAX. SPEED -	60 mile/h
WHEELS -	952 DIA.
JOURNALS -	140 DIA. ROLLER BEARINGS

BUFFERS -	HYDRAULIC 406 DIA. HEADS
COUPLINGS -	INTERNATIONAL SCREW
MIN CURVE -	31 m
GEN ARRGT DRG No -	
BRAKE -	VACUUM BLOCK & HAND LEVER
SUSPENSION -	DOUBLE LINK

BUILDER -	METRO CAMELL
OWNER -	B. R. T. & E.
REGISTERED BY -	C. M. & E. E. (B. R. B.) DERBY
YEAR BUILT -	1965
REGISTRATION Nos. -	57041 TO 57060
OWNERS Nos. -	5573 TO 5592

ISSUE 2

EX. PO. DIAGRAM 6/177

46 tonnes G.L.W. TANK WAGON - CLASS A

TTO35B

EXCESS LENGTH	4	H	M	L	E
tonnes	46	46	14	14	
VB	17	17	7	7	
AB					
RA	8	8	1	1	
MAX SPEED	60	60	45	45	

TOPS CODE					
CARKND	AARKND	OPERATING PANEL No			
T	T	F	T	F	A
I	5	O	5		

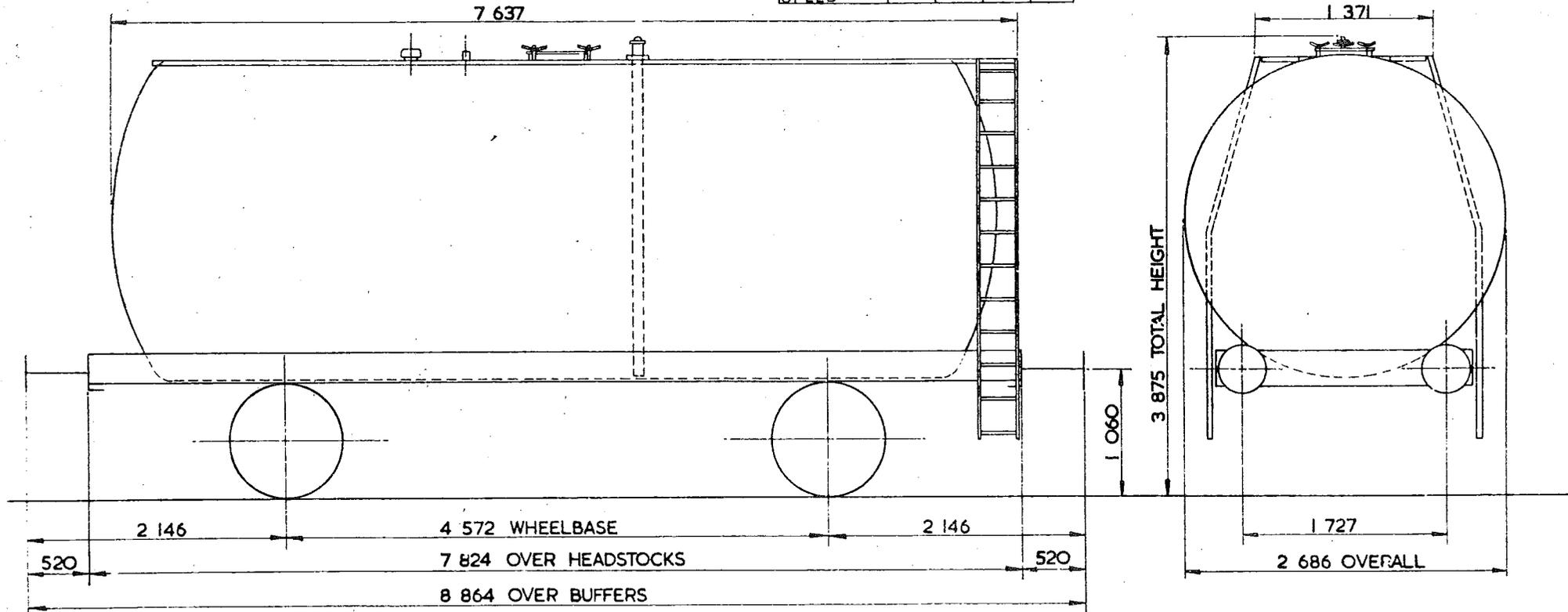

TARE -	14 350 kg
CARRYING CAPACITY -	31 800 kg
CAPACITY -	39 296 litres
MAX. SPEED -	60 mile/h
WHEELS -	952 DIA
JOURNALS -	140 DIA ROLLER BEARINGS

BUFFERS -	HYDRAULIC 406 DIA HEADS
COUPLINGS -	INSTANTER
MIN. CURVE -	31 m
GEN. ARRGT. DRG. No -	
BRAKE -	VACUUM BLOCK & HAND LEVER.
SUSPENSION -	DOUBLE LINK

BUILDER -	METRO CAMELL
OWNER -	SUKO & BPO
REGISTERED BY -	C.M. & E.E. (B.R.B.) DERBY
YEAR BUILT -	1964
REGISTRATION Nos. -	SUKO 64130 TO 64141 BPO 64180 TO 64187
OWNERS Nos. -	

ISSUE 2

EX. PO. DIAGRAM 6/176.

46 tonnes G.L.W. TANK WAGON - CLASS A

TTO35C

EXCESS LENGTH	4	H	M	L	E
tonnes	46	46	14	14	
VB	19	19	8	8	
AB					
RA	8	8	1	1	
MAX. SPEED	60	60	45	45	

TOPS CODE		
CARKND	AARKND	OPERATING PANFL No
T T F	T T F A	I 5 0 I

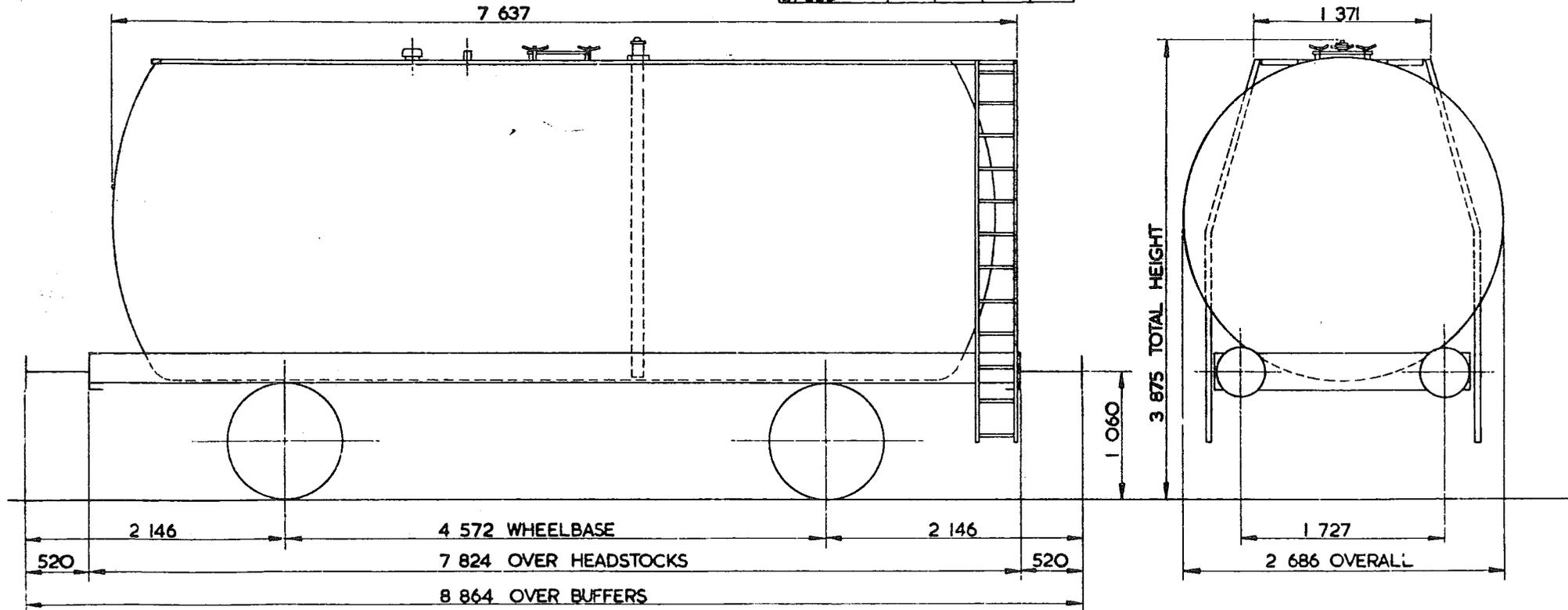

TARE -	13550 kg
CARRYING CAPACITY -	32 400 kg
CAPACITY -	39277 litres
MAX. SPEED -	60 mile/h
WHEELS -	952 DIA
JOURNALS -	140 DIA ROLLER BEARINGS

BUFFERS -	HYDRAULIC 406 DIA HEADS
COUPLINGS -	INSTANTER
MIN. CURVE -	31 m
GEN. ARRG. DRG. No. -	
BRAKE -	VACUUM BLOCK & HAND LEVER.
SUSPENSION -	DOUBLE LINK

BUILDER -	METRO-CAMMELL
OWNER -	SUKO & B.P.O
REGISTERED BY -	C.M. & E.E. (B.R.B.) DERBY.
YEAR BUILT -	1964
REGISTRATION Nos. -	SUKO 60119 TO 68311 (RANGE) BPO 60266 TO 68371 (RANGE)
OWNERS Nos. -	

ISSUE 2
EX. P.O. DIAGRAM 6/152.

46 tonnes G.L.W. TANK WAGON-CLASS B-COILED

TTO35D

EXCESS LENGTH	4	H	M	L	E
tonnes	46	46	15	15	
VB	19	19	8	8	
AB					
RA	8	8	1	1	
MAX. SPEED	60	60	45	45	

TOPS CODE										
CARKND		AARKND			OPERATING PANEL No					
T	T	F	T	T	F	A	1	4	9	0

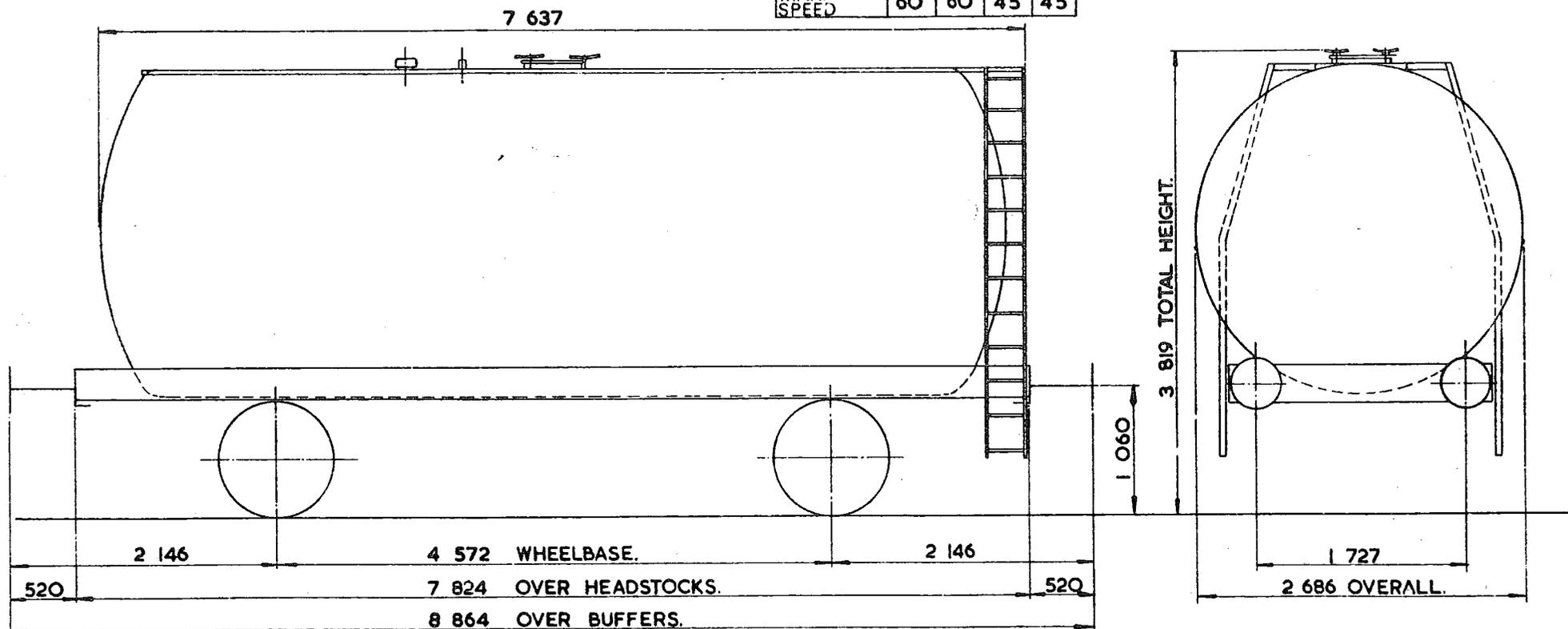

TARE -	14 350 kg.
CARRYING CAPACITY -	31 600 kg.
CAPACITY -	39 296 litres.
MAX. SPEED -	60 mile/h.
WHEELS -	952 DIA.
JOURNALS -	140 DIA. ROLLER BEARINGS.

BUFFERS -	HYDRAULIC 406 DIA. HEADS.
COUPLINGS -	INSTANTER.
MIN. CURVE -	31 m.
GEN. ARRGT. DRG. No. -	
BRAKE -	VACUUM BLOCK & HAND LEVER
SUSPENSION -	DOUBLE LINK.

BUILDER -	METRO-CAMMELL.
OWNER -	SUKO & BPO.
REGISTERED BY -	C.M.&E.E. (B.R.B.) DERBY.
YEAR BUILT -	1964/65.
REGISTRATION Nos. -	SUKO 64100 TO 64122, BPO 64160 TO 64176.
OWNERS Nos. -	

ISSUE 2

EX. P.O. DIAGRAM 6/175.

46 tonnes G.L.W. TANK WAGON - CLASS B

TTO35E

EXCESS LENGTH	4	H	M	L	E
tonnes	46	46	14	14	
VB	19	19	8	8	
AB					
RA	8	8	1	1	
MAX. SPEED	60	60	45	45	

TOPS CODE										
CARKND		AARKND			OPERATING PANEL No.					
T	T	F	T	T	F	A	I	5	O	I

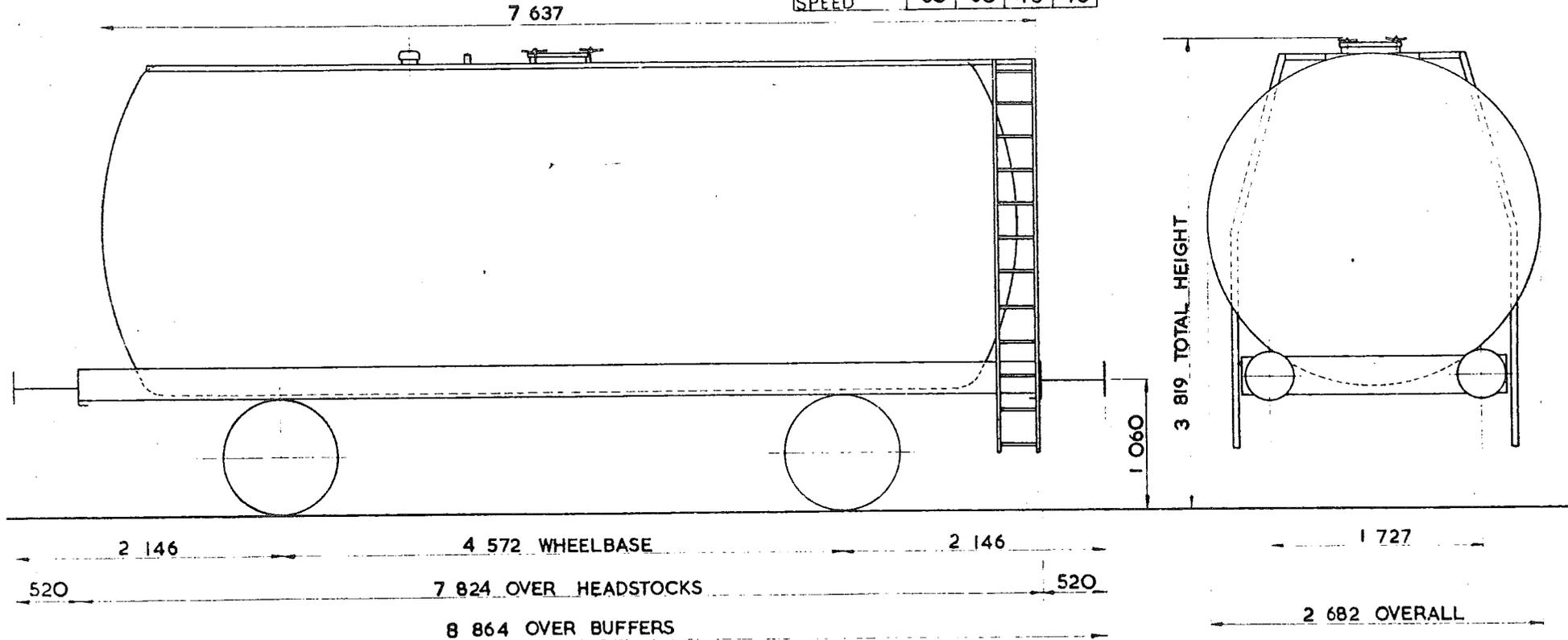

TARE - 13 300 kg
CARRYING CAPACITY - 32 700 kg
CAPACITY - 39 277 litres
MAX. SPEED - 60 mile/h
WHEELS - 952 DIA.
JOURNALS - 140 DIA. ROLLER BEARINGS

BUFFERS - HYDRAULIC 406 DIA. HEADS
COUPLINGS - INSTANTER
MIN. CURVE - 31m
GEN ARRG'T DRG No. -
BRAKE - VACUUM BLOCK & HAND LEVER
SUSPENSION - DOUBLE LINK

BUILDER - METRO CAMELL
OWNER - SUKO & BPO
REGISTERED BY - C.M. & E.E. (B.R.B.) DERBY
YEAR BUILT - 1965
REGISTRATION Nos. - SUKO 66100 TO 66117 BPO 66160 TO 66171
OWNERS Nos. -

ISSUE 2
EX RO. DIAGRAM 6/188

46 tonnes G.L.W. TANK WAGON CLASS A

TT035G

DESIGN SHEET No. W769

EXCESS LENGTH	L	H	M	L	E
tonnes	46	46	13	13	
VB					
AB	25	25	9	9	
RA	8	8	1	1	
MAX. SPEED	60	60	60	60	

TOPS CODE										
CARKND	AARKND				OPERATING PANEL No.					
T	T	A	T	T	A	A	1	5	9	3

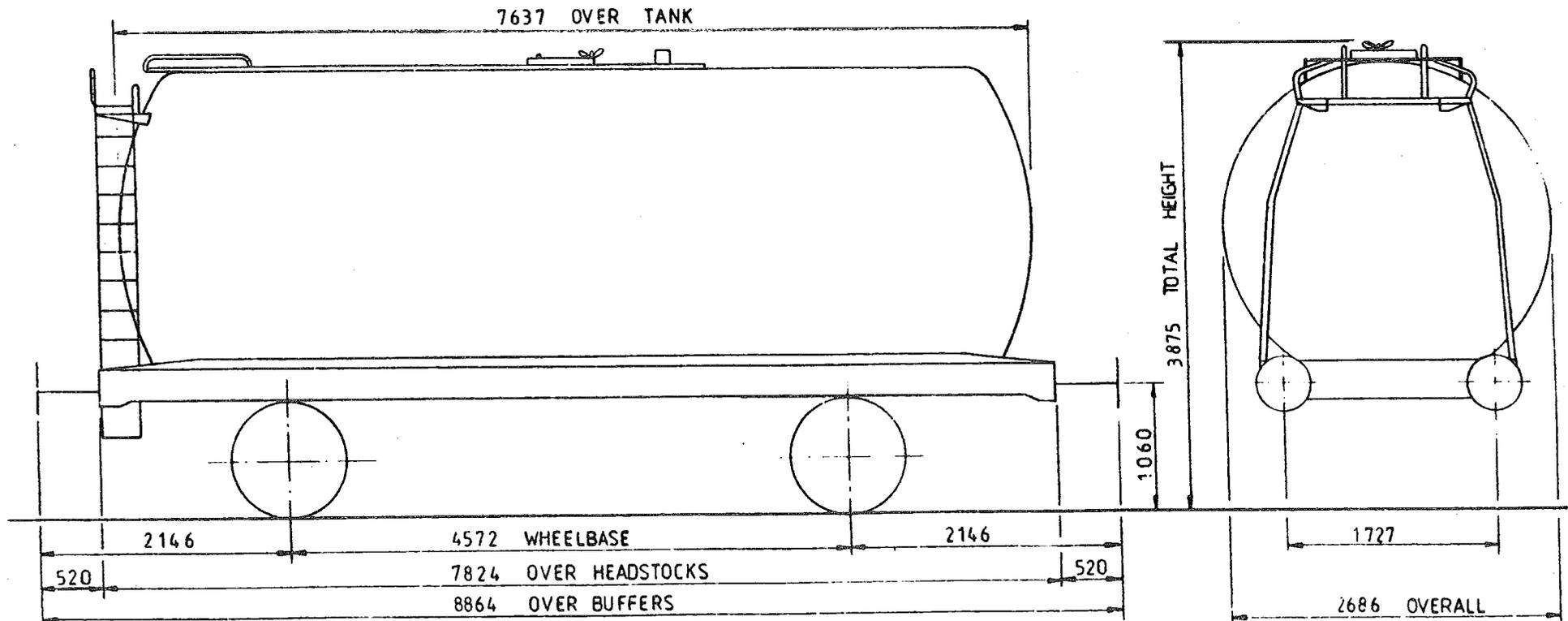

TARE —	12 500 kg
CARRYING CAPACITY —	33 500 kg
CAPACITY —	39277 Litres
MAX SPEED —	60 mile/h
WHEELS —	Ø 952
JOURNALS —	Ø140 ROLLER BEARINGS

BUFFERS —	HYDRAULIC Ø406 HEADS
COUPLINGS —	INSTANTER
MIN. CURVE —	31 m
GEN. ARRGT DRG No —	
BRAKE —	AIR, BLOCK & HAND LEVER
SUSPENSION —	PARABOLIC SHORT LINK

ISSUE 2.

46 tonne GLW TANK WAGON-CLASS 'B'

LOT NUMBER	

TOPS INFORMATION						
AARKND	OPERATING	OPERATING SPEED		BRAKE FORCE DATA		EXCESS LENGTH
CARKND	PANEL No.	60 mile/h UP TO	46 tonne GLW	5 t FORCE UP TO	30.5 tonne GLW	RA (GLW)
T T A A		mile/h ABOVE		25 t FORCE ABOVE		DESIGN SHEET
						W1157

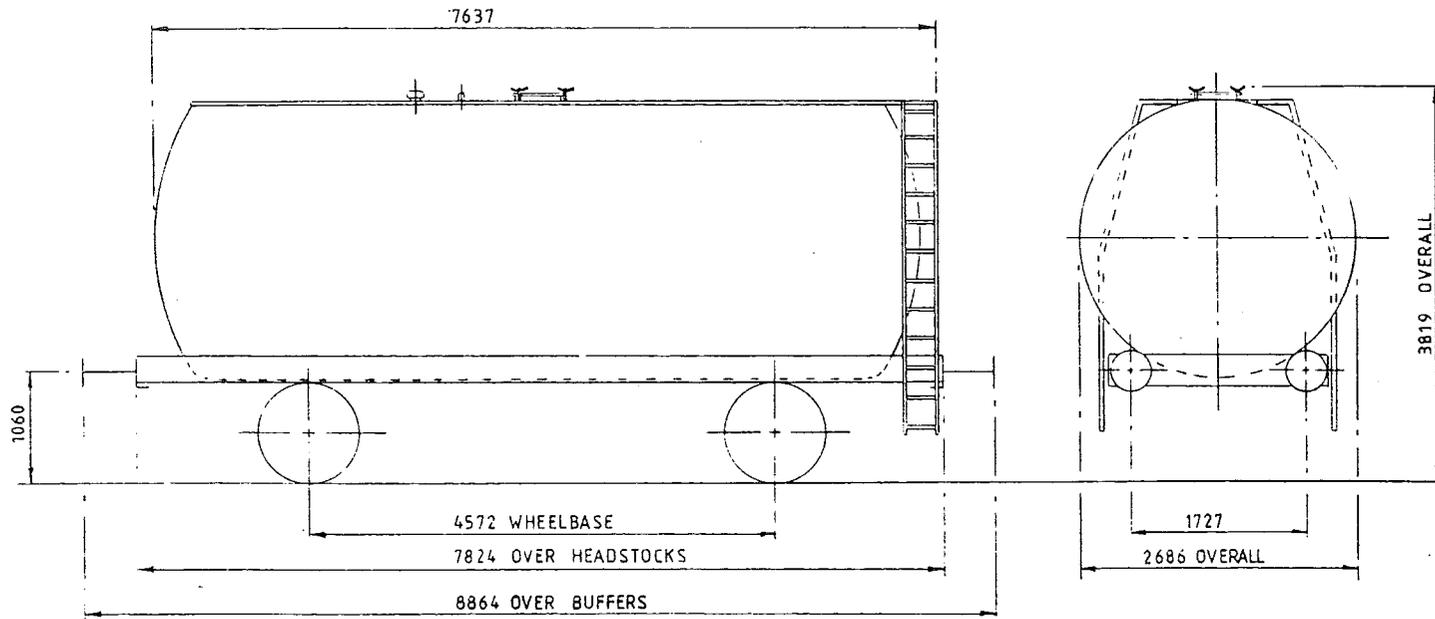

TARE-	15.100 Kg
CAPACITY, WEIGHT-	30.900 Kg
CAPACITY, VOLUME-	39.296 litres
MIN. CURVE-	31m
GEN. ARRGT. DRG. NO.-	

BRAKE-	AIR BLOCK & HAND LEVER
SUSPENSION-	DOUBLE LINK & PARABOLIC SPRING
COUPLINGS-	INSTANTER
BUFFERS-	HYDRAULIC 406 DIA HEADS
WHEELS-	952 DIA
JOURNALS-	140 DIA ROLLER BEARINGS

ISSUE 1

46 tonne GLW TANK WAGON-CLASS 'B'

LOT NUMBER	

TOPS INFORMATION												
AARKND		OPERATING		OPERATING SPEED			BRAKE FORCE DATA			EXCESS LENGTH	RA (GLW)	DESIGN SHEET
CARKND	PANEL No.	60 mile/h UP TO			46 tonne GLW	5 t FORCE UP TO			30.5 tonne GLW	4	9	W1159
T	T	A	A									

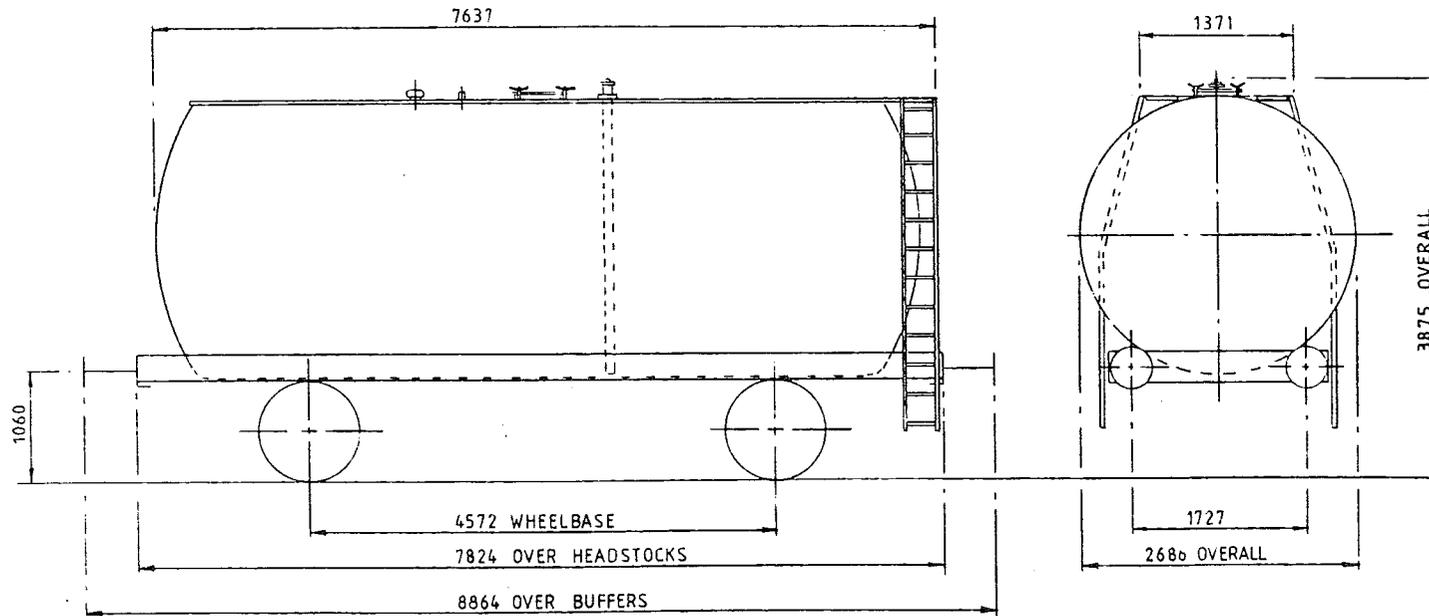

TARE-	14,500 Kg
CAPACITY, WEIGHT-	31,500 Kg
CAPACITY, VOLUME-	39,296 litres
MIN. CURVE-	31m
GEN. ARRGT. DRG. NO.-	

BRAKE-	AIR BLOCK & HAND LEVER
SUSPENSION-	DOUBLE LINK & PARABOLIC SPRING
COUPLINGS-	INSTANTER
BUFFERS-	HYDRAULIC 406 DIA HEADS
WHEELS-	952 DIA
JOURNALS-	140 DIA ROLLER BEARINGS

ISSUE I

46 tonne GLW TANK WAGON-CLASS 'A'

LOT NUMBER	

TOPS INFORMATION										
AARKND		OPERATING		OPERATING SPEED		BRAKE FORCE DATA		EXCESS LENGTH	RA (GLW)	DESIGN SHEET
CARKND		PANEL No.		60 mile/h UP TO 46 tonne GLW		5t FORCE UP TO 31 tonne GLW				
T	T	A	A					4	9	W1224

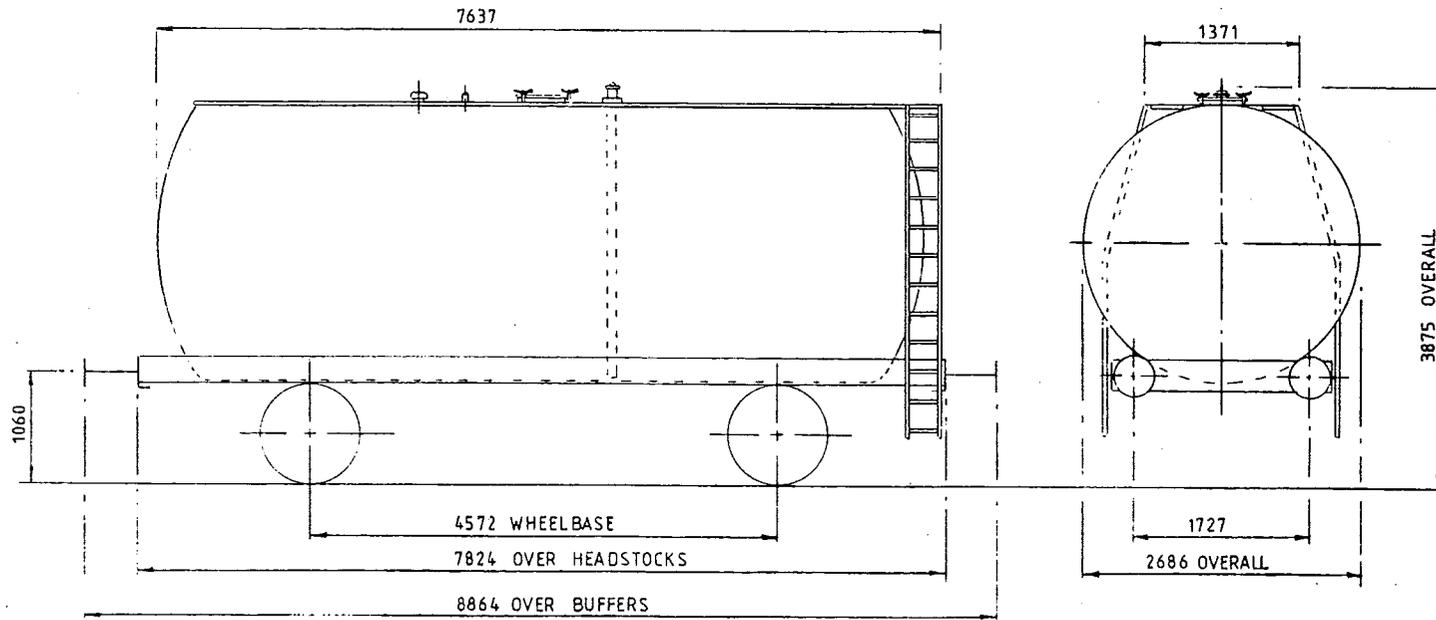

TARE-	12.600 Kg
CAPACITY, WEIGHT-	33.400 Kg
CAPACITY, VOLUME-	39.277 litres
MIN. CURVE-	31m
GEN. ARRGT. DRG. NO.-	

BRAKE-	AIR BLOCK & HAND LEVER
SUSPENSION-	DOUBLE LINK & PARABOLIC SPRING
COUPLINGS-	INSTANTER
BUFFERS-	HYDRAULIC 406 DIA HEADS
WHEELS-	952 DIA
JOURNALS-	140 DIA ROLLER BEARINGS

ISSUE I

46 tonne GLW TANK WAGON-CLASS 'A'

LOT NUMBER	

TOPS INFORMATION										
AARKND	OPERATING			OPERATING SPEED		BRAKE FORCE DATA		EXCESS LENGTH	RA (GLW)	DESIGN SHEET
CARKND	PANEL No.			60 mile/h UP TO	46 tonne GLW	5 t FORCE UP TO	30.5 tonne GLW	4	8	W1298
T T A A				mile/h ABOVE		23 t FORCE ABOVE				

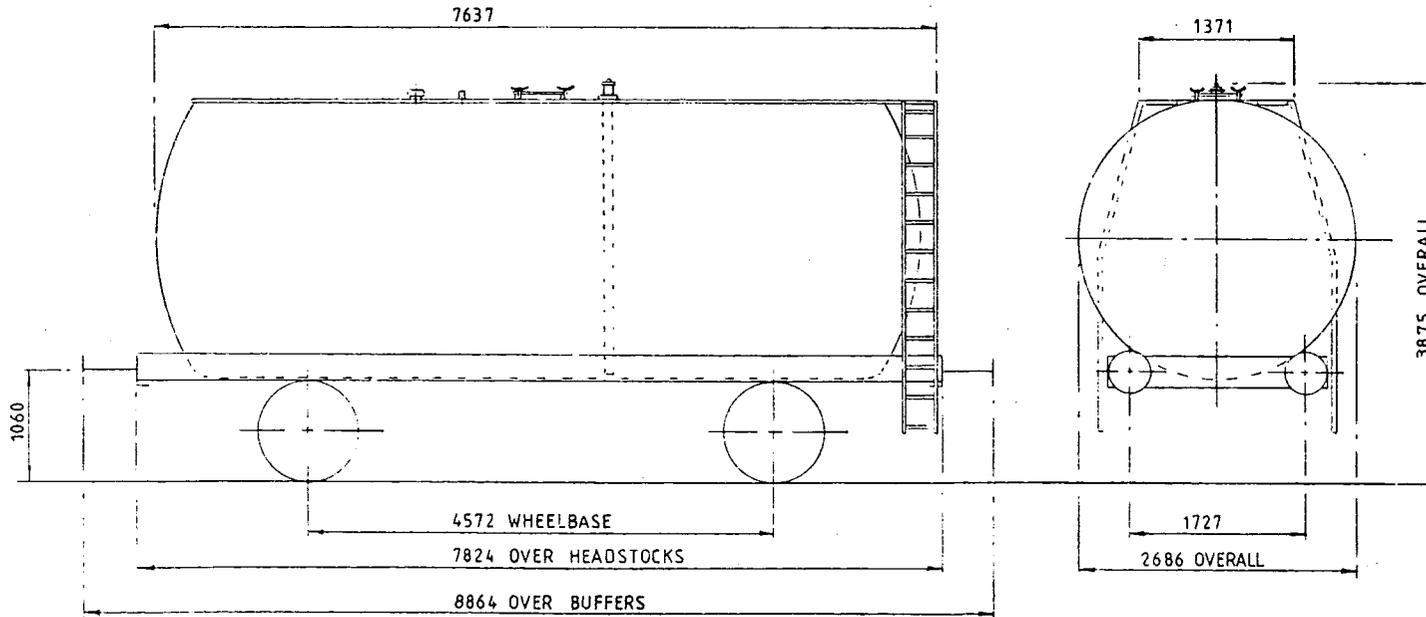

TARE-	13.500 Kg
CAPACITY, WEIGHT-	32.500 Kg
CAPACITY, VOLUME-	39.277 litres
MIN. CURVE-	31m
GEN. ARRGT. DRG. NO.-	

BRAKE-	AIR BLOCK & HAND LEVER
SUSPENSION-	DOUBLE LINK & PARABOLIC SPRING
COUPLINGS-	INSTANTER
BUFFERS-	HYDRAULIC 406 DIA HEADS
WHEELS-	952 DIA
JOURNALS-	140 DIA ROLLER BEARINGS

ISSUE 1

46 tonne GLW TANK WAGON-CLASS 'B'

LOT NUMBER	

TOPS INFORMATION												
AARKND		OPERATING		OPERATING SPEED			BRAKE FORCE DATA			EXCESS LENGTH	RA (GLW)	DESIGN SHEET
CARKND		PANEL No.		45 mile/h UP TO 13.5 tonne GLW			8t FORCE UP TO 31 tonne GLW					
T	T	G	A							4	8	W1348

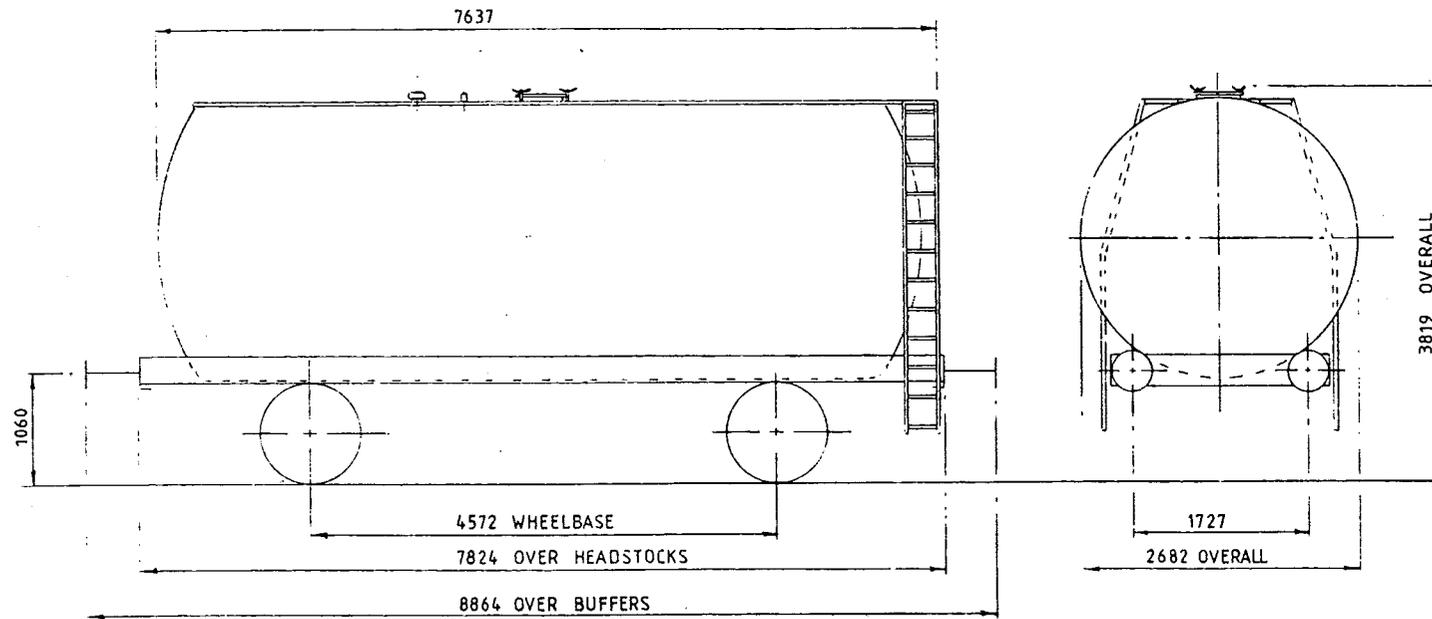

TARE-	13.300 Kg
CAPACITY, WEIGHT-	32.700 Kg
CAPACITY, VOLUME-	39.277 litres
MIN. CURVE-	31m
GEN. ARRGT. DRG. NO.-	

BRAKE-	VAC. BLOCK, AIR PIPED, HAND LEVER
SUSPENSION-	DOUBLE LINK
COUPLINGS-	INSTANTER
BUFFERS-	HYDRAULIC 406 DIA HEADS
WHEELS-	952 DIA
JOURNALS-	140 DIA ROLLER BEARINGS

ISSUE 1

46 tonne GLW TANK WAGON-CLASS B'

LOT NUMBER	

TOPS INFORMATION						
AARKND	OPERATING	OPERATING SPEED		BRAKE FORCE DATA		EXCESS LENGTH
CARKND	PANEL No.	60 mile/h UP TO	46 tonne GLW	5 t FORCE UP TO	30.5 tonne GLW	RA (GLW)
T T A A		mile/h ABOVE		24t FORCE ABOVE		4
						9
						W1350

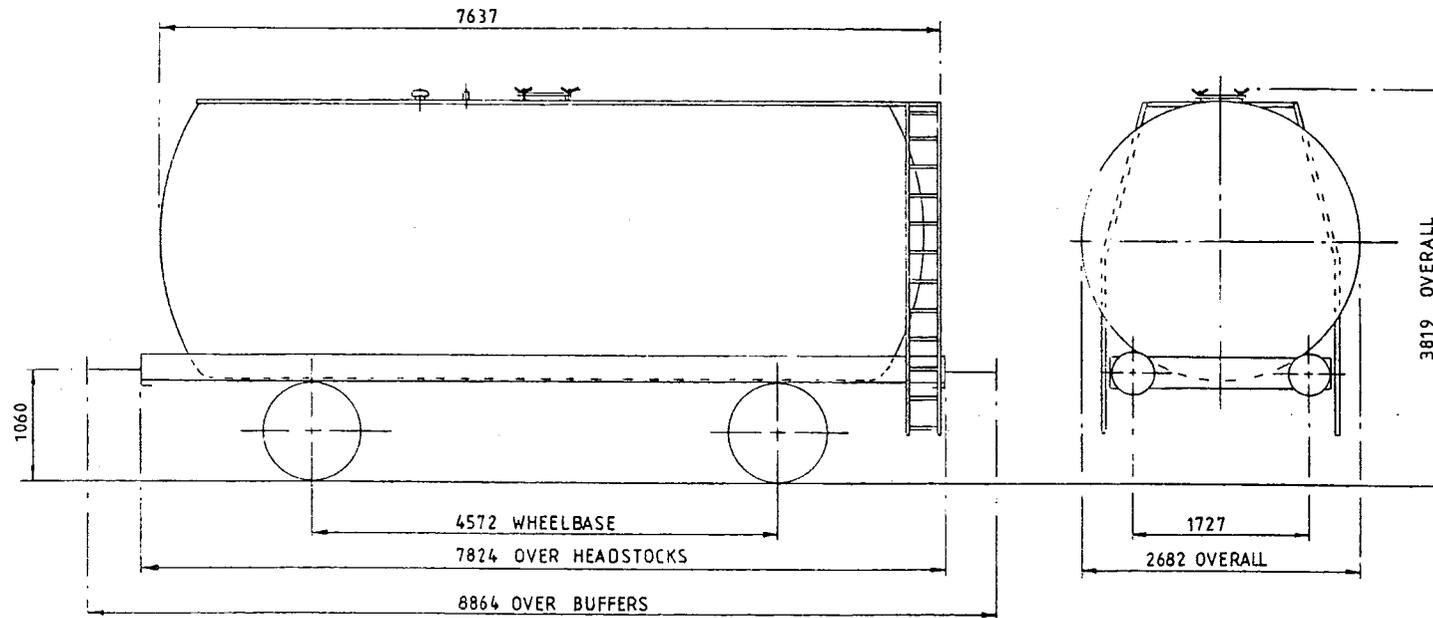

TARE-	12.550 Kg
CAPACITY, WEIGHT-	33.450 Kg
CAPACITY, VOLUME-	39.277 litres
MIN. CURVE-	31m
GEN. ARRGT. DRG. NO.-	

BRAKE-	AIR BLOCK & HAND LEVER
SUSPENSION-	DOUBLE LINK & PARABOLIC SPRING
COUPLINGS-	INSTANTER
BUFFERS-	HYDRAULIC 406 DIA HEADS
WHEELS-	952 DIA
JOURNALS-	140 DIA ROLLER BEARINGS

ISSUE 1

46 tonne GLW TANK WAGON-CLASS 'B' COILED

LOT NUMBER	

TOPS INFORMATION						
AARKND	OPERATING	OPERATING SPEED		BRAKE FORCE DATA		EXCESS LENGTH
CARKND	PANEL No.	60 mile/h UP TO	46 tonne GLW	6t FORCE UP TO	30.5 tonne GLW	RA (GLW)
T	A A	mile/h ABOVE		25t FORCE ABOVE		4
						9
						W1326

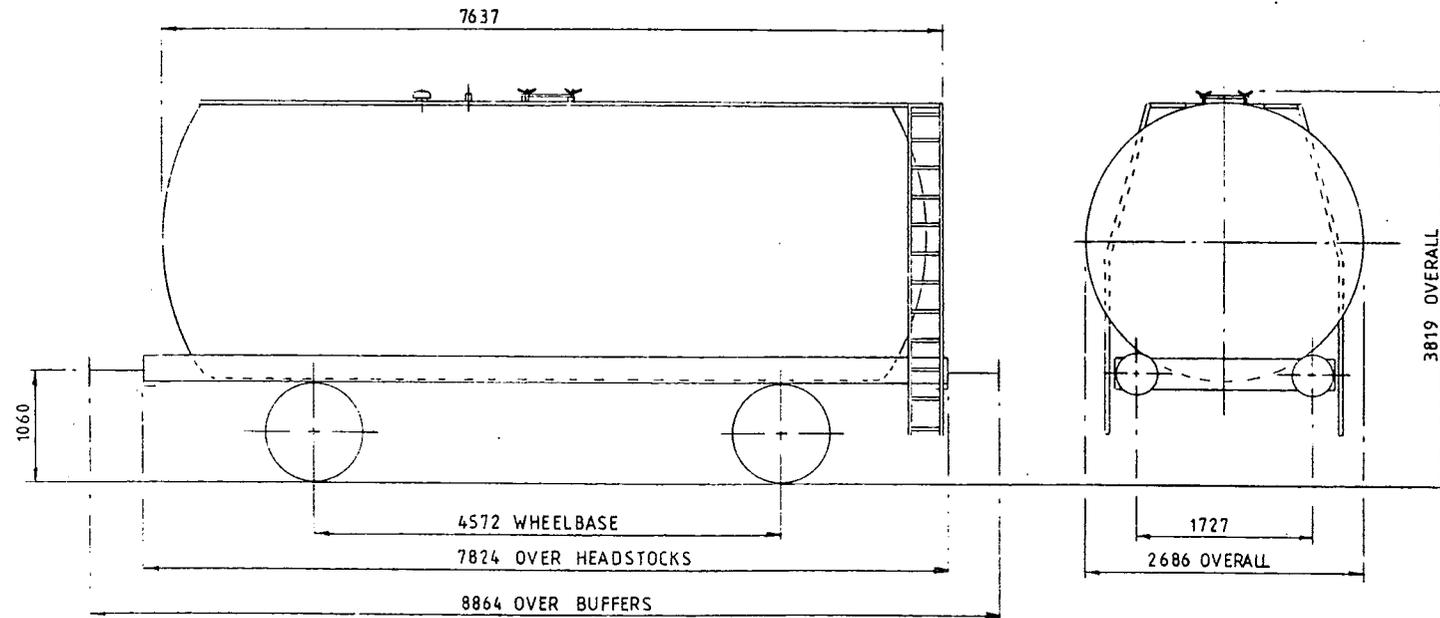

TARE-	14.650 Kg
CAPACITY, WEIGHT-	31.350 Kg
CAPACITY, VOLUME-	39.296 litres
MIN. CURVE-	31m
GEN. ARRGT. DRG. NO.-	

BRAKE-	AIR BLOCK & HAND LEVER
SUSPENSION-	DOUBLE LINK & PARABOLIC SPRING
COUPLINGS-	INSTANTER
BUFFERS-	HYDRAULIC 406 DIA HEADS
WHEELS-	952 DIA
JOURNALS-	140 DIA ROLLER BEARINGS

ISSUE 1

46 tonnes G.L.W. TANK WAGON

TTO36A

EXCESS LENGTH	H	M	L	E
tonnes	46	46	14	14
VB	19	19	8	8
AB				
RA	8	8	1	1
MAX. SPEED	60	60	45	45

TOPS CODE										
CARKND		AARKND			OPERATING PANEL No					
T	T	F	T	T	F	A	I	5	O	I

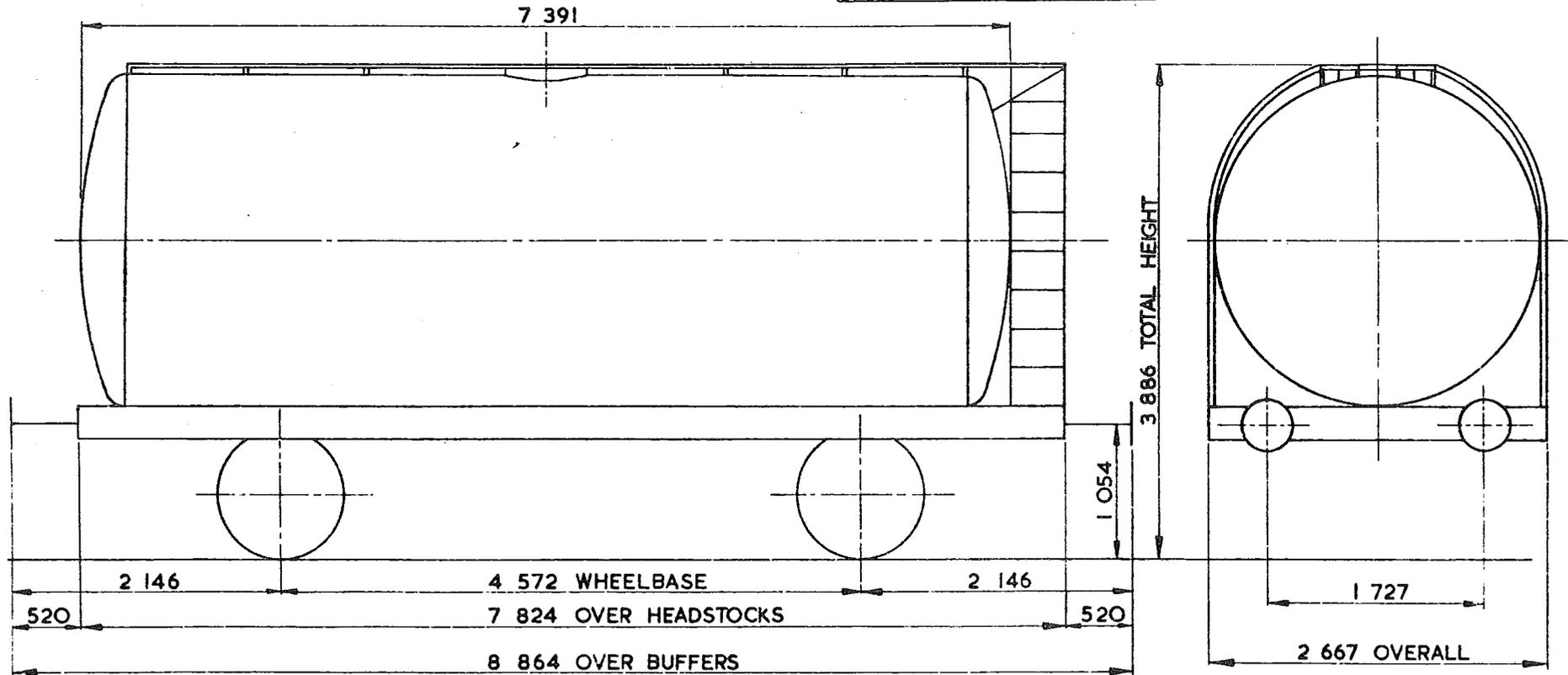

TARE -	14,100kg
CARRYING CAPACITY -	31,900kg
CAPACITY -	38,186 litres
MAX. SPEED -	60 miles/h
WHEELS -	952 DIA.
JOURNALS -	140 DIA. ROLLER BEARINGS

BUFFERS -	HYDRAULIC 406 DIA. HEADS
COUPLINGS -	INSTANTER
MIN. CURVE -	31m
GEN. ARRGT. DRG. No. -	
BRAKE -	VACUUM BLOCK & HAND LEVER
SUSPENSION -	DOUBLE LINK

ISSUE 2
EX. PO. DIAGRAM 6/795 (ALLOCATED)

46 tonnes G.L.W. TANK WAGON

TTO36B

EXCESS LENGTH 4	H	M	L	E
tonnes	46	46	14	14
VB	19	19	8	8
AB	0	0	0	0
RA	8	8	1	1
MAX SPEED	60	60	45	45

TOPS CODE									
CARKND		AARKND			OPERATING PANEL No.				
T	T	G	T	G	A	I	S	O	B

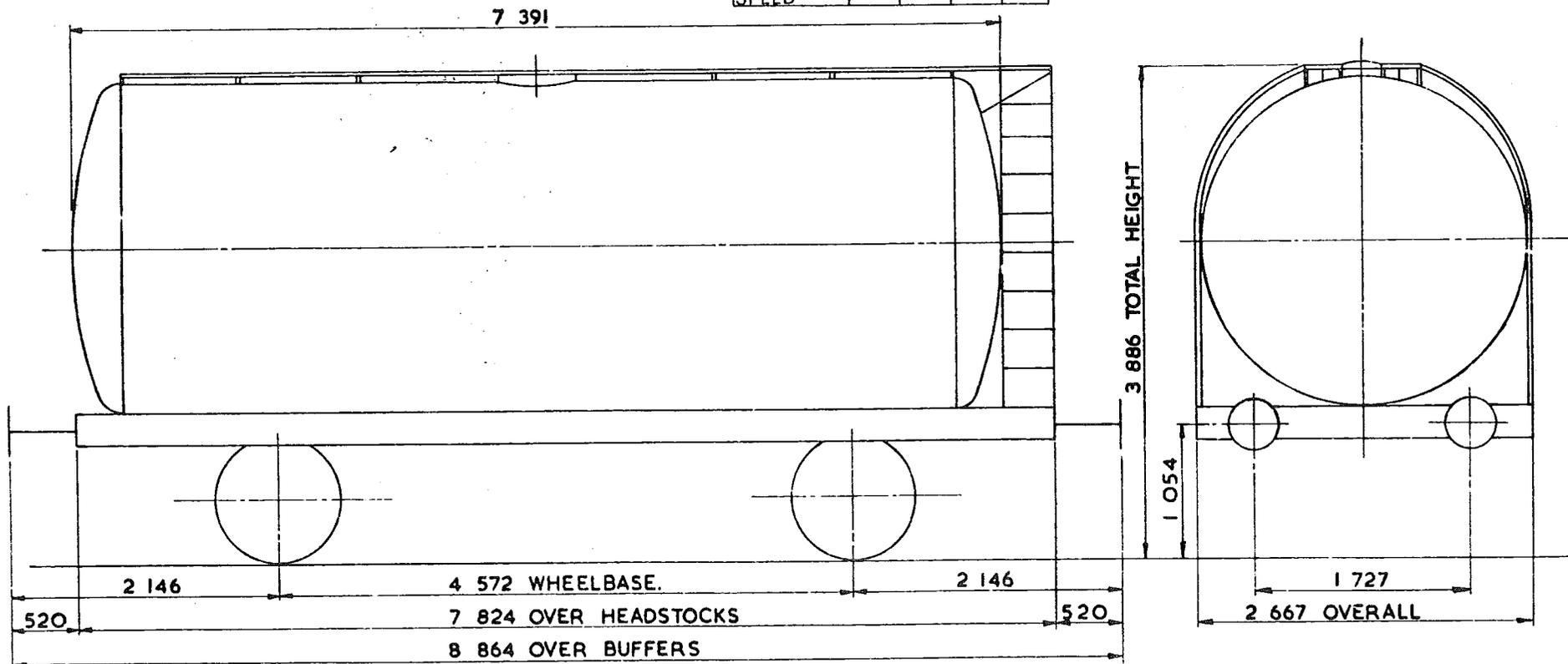

TARE -	13 450 kg
CARRYING CAPACITY -	32 500 kg
CAPACITY -	38 641 litres
MAX. SPEED -	60 mile/h
WHEELS -	952 DIA.
JOURNALS -	140 DIA. ROLLER BEARINGS

BUFFERS -	HYDRAULIC 406 DIA. HEADS
COUPLINGS -	INSTANTER
MIN. CURVE -	31 m
GEN. ARRGT. DRG. No. -	
BRAKE -	VACUUM BLOCK AIR PIPED & HAND LEVER
SUSPENSION -	DOUBLE LINK

ISSUE 2
EX. P.O. DIAGRAM 6/797 (ALLOCATED).

46 tonne GLW TANK WAGON-CLASS 'B'

LOT NUMBER	

TOPS INFORMATION											
AARKND		OPERATING		OPERATING SPEED			BRAKE FORCE DATA		EXCESS LENGTH	RA (GLW)	DESIGN SHEET
CARKND		PANEL No.		60 mile/h UP TO 46 tonne GLW			5t FORCE UP TO 30.5 tonne GLW		4	9	W1183
T	T	A	A	mile/h ABOVE			22t FORCE ABOVE				

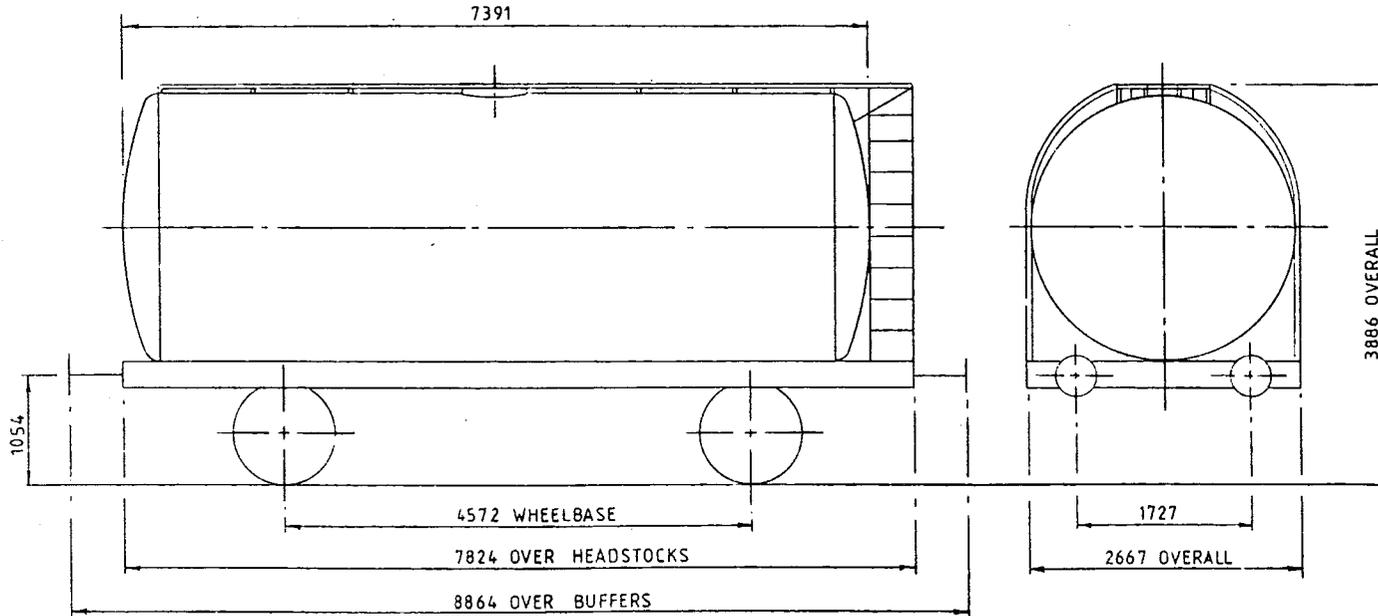

TARE-	13,050 Kg
CAPACITY, WEIGHT-	32,950 Kg
CAPACITY, VOLUME-	38,786 litres
MIN. CURVE-	31m
GEN. ARRGT. DRG. NO.-	

BRAKE-	AIR BLOCK & HAND LEVER
SUSPENSION-	DOUBLE LINK
COUPLINGS-	INSTANTER
BUFFERS-	HYDRAULIC 406 DIA HEADS
WHEELS-	952 DIA
JOURNALS-	140 DIA ROLLER BEARINGS

ISSUE 1

46 tonne GLW TANK WAGON - CLASS B

LOT NUMBER	

TOPS INFORMATION						
AARKND	OPERATING	OPERATING SPEED		BRAKE FORCE DATA		EXCESS LENGTH
CARKND	PANEL No.	60 mile/h UP TO	46 tonne GLW	5t FORCE UP TO	30.5 tonne GLW	4
T T A A		mile/h ABOVE		22t FORCE ABOVE		9
						W1182

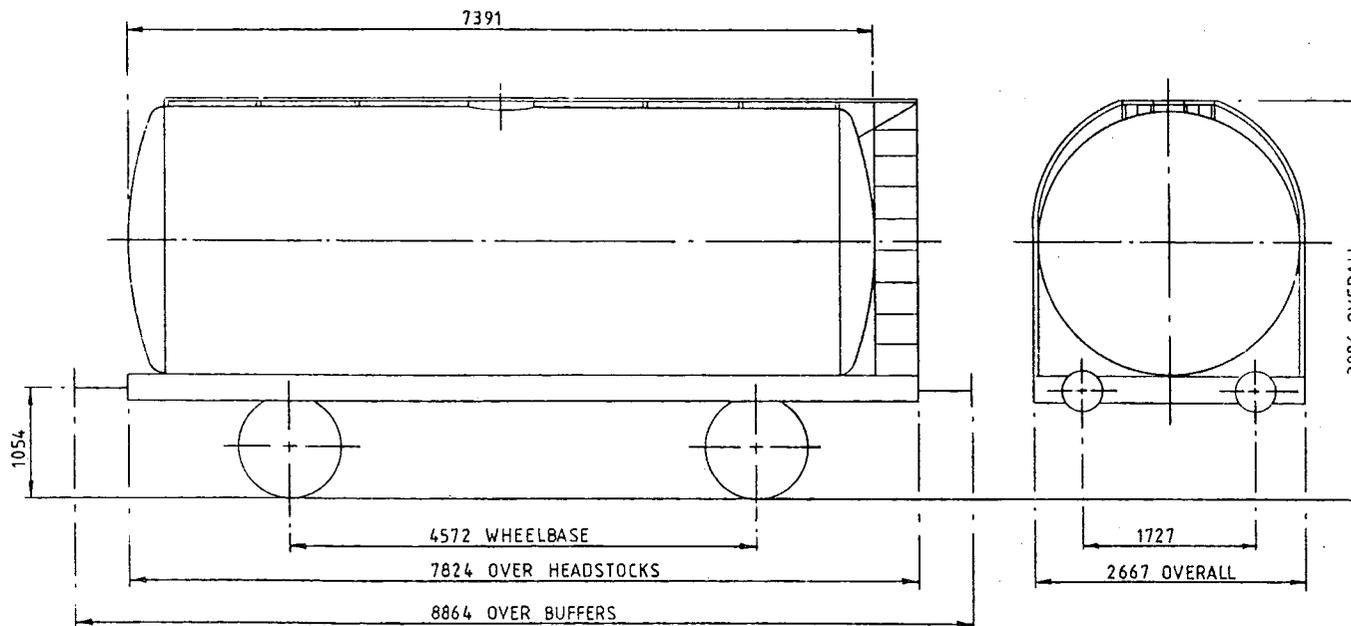

TARE-	13.200 Kg
CAPACITY, WEIGHT-	32.800 Kg
CAPACITY, VOLUME-	38.641 litres
MIN. CURVE-	31 m
GEN. ARRGT. DRG. NO.-	

BRAKE-	AIR BLOCK & HAND LEVER
SUSPENSION-	DOUBLE LINK
COUPLINGS-	INSTANTER
BUFFERS-	HYDRAULIC 406 DIA HEADS
WHEELS-	952 DIA
JOURNALS-	140 DIA ROLLER BEARINGS

ISSUE 1

46 tonnes G.L.W. TANK WAGON - CLASS B

TTO37A

EXCESS LENGTH 4	H	M	L	E
tonnes	46	46	14	14
VB	17	17	7	7
AB				
RA	8	8	1	1
MAX SPEED	60	60	45	45

TOPS CODE	
CARKND	AARKND
T T F T T F A I S O S	

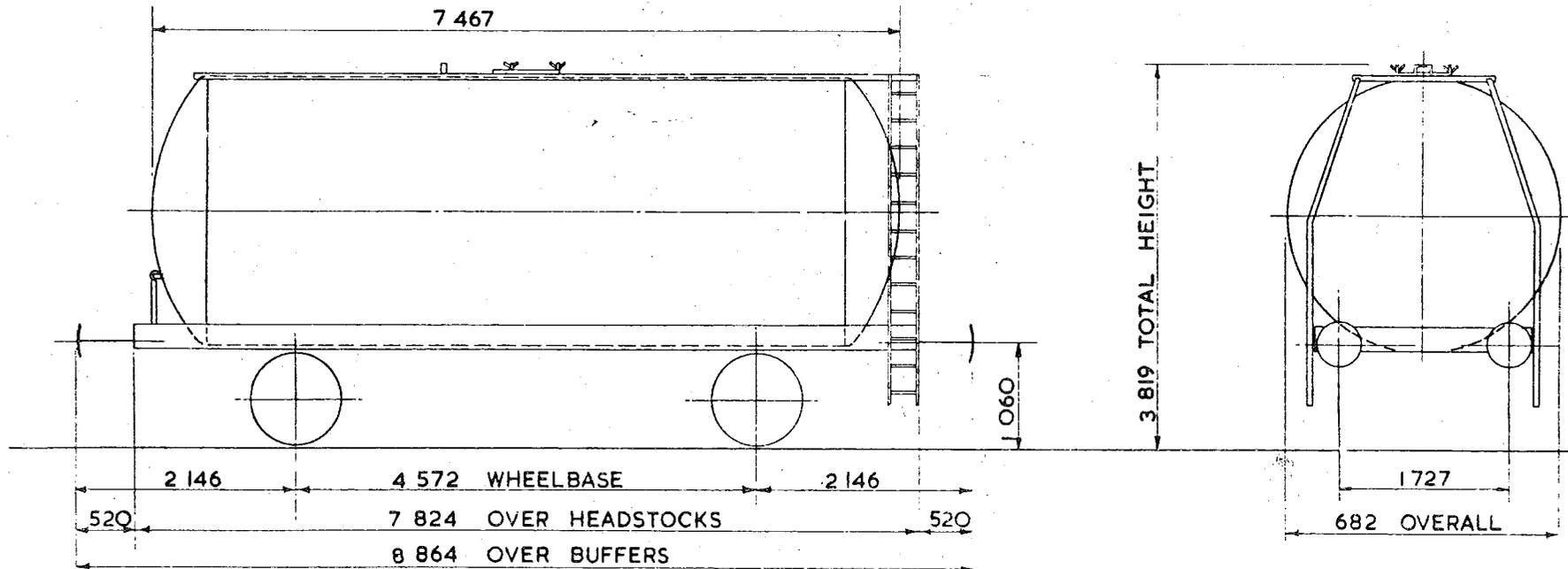

TAKE 14350kg.
CARRYING CAPACITY - 31600kg.
CAPACITY - 39196 litres.
MAX SPEED - 60 mile/h.
WHEELS - 952 DIA.
JOURNALS - 140 DIA. ROLLER BEARINGS

BUFFERS HYDRAULIC 406 DIA. HEADS.
COUPLINGS - INSTANTER
MIN CURVE - 31m.
GEN. ARRGT DRG No -
BRAKE - VACUUM BLOCK & HAND LEVER.
SUSPENSION - DOUBLE LINK

BUILDER - METRO CAMELL
OWNER - ALGECO
REGISTERED BY - C.M.&E.E. (B.R.B.) DERBY.
YEAR BUILT - 1965
REGISTRATION Nos. 49254 TO 49290
OWNERS Nos - 186596 TO 186645 (RANGE)

ISSUE 2

EX. P.O. DIAGRAM 6/173

46 tonnes GL.W. TANK WAGON

TTO39B

EXCESS LENGTH	4	H	M	L	E
tonnes	46	46	13	13	
VB					
AB	22	22	10	10	
RA	8	8	1	1	
MAX. SPEED	60	60	45	45	

TOPS CODE		
CARKND	AAPKND	RESERVED
T	T	A
T	T	A
A	I	4
9	1	

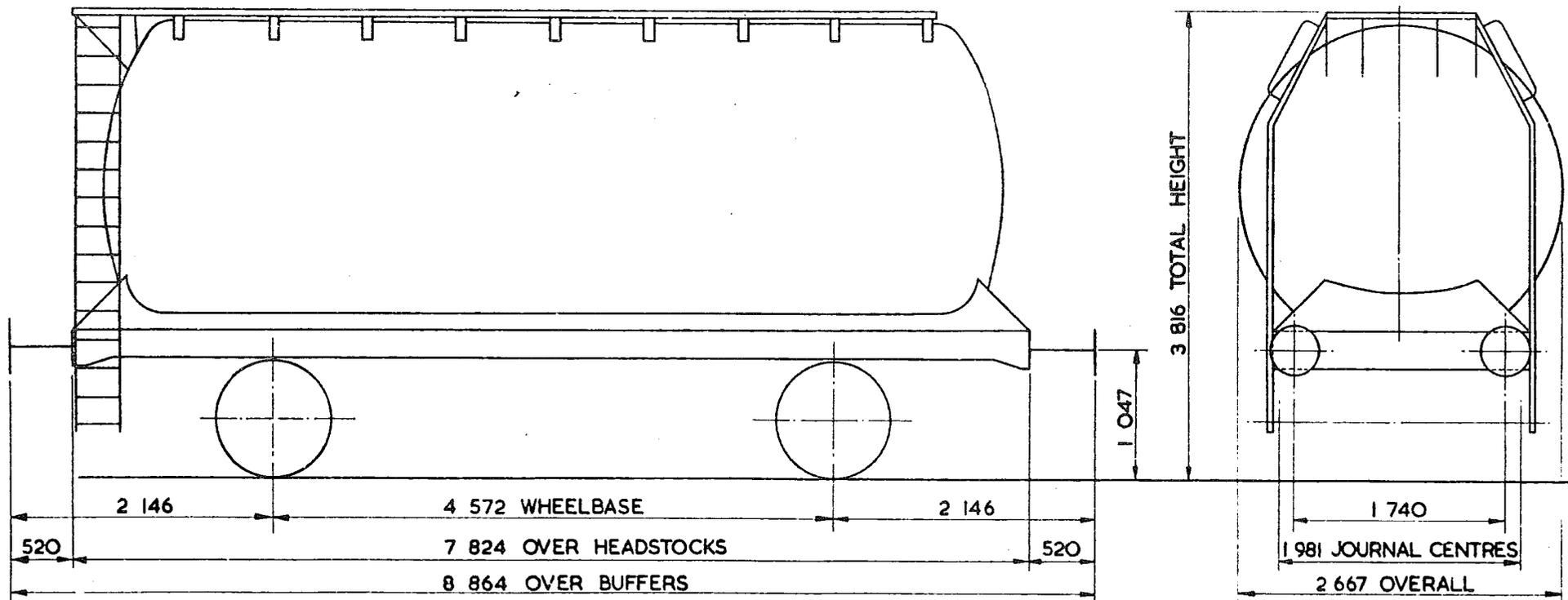

TARE --	13 200 kg
CARRYING CAPACITY --	32 800 kg
CAPACITY --	18 502 litres
MAX. SPEED --	60 mile/h
WHEELS --	952 DIA.
JOURNALS --	140 DIA. ROLLER BEARINGS

BUFFERS --	HYDRAULIC 406 DIA. HEADS
COUPLINGS --	INSTANTER
MIN CURVE --	31m
GEN ARRGT DRG No. --	
BRAKE --	AIR BLOCK & HAND LEVER
SUSPENSION --	DOUBLE LINK

BUILDER --	ROOTES PRESSING
OWNER --	STORAGE & TRANSPORT SYSTEM
REGISTERED BY --	C.M.&E.E. (B.R.B.) DERBY
YEAR BUILT --	1966
REGISTRATION Nos	53111 TO 53128
OWNERS Nos. --	1011 TO 1028

ISSUE 2

EX. P.O. DIAGRAM 6/747 (ALLOCATED)

46 tonne GLW TANK WAGON

TT 039 C

EXCESS LENGTH	4	H	M	L	E
tonnes	46	46	13	13	
VB					
AB	18	16	7	7	
RA	8	8	1	1	
MAX SPEED	60	60	60	60	

TOPS CODE					
CARKND	AARKND			OPERATING PANEL N°	
T	T	A	T	A	A
				8	63

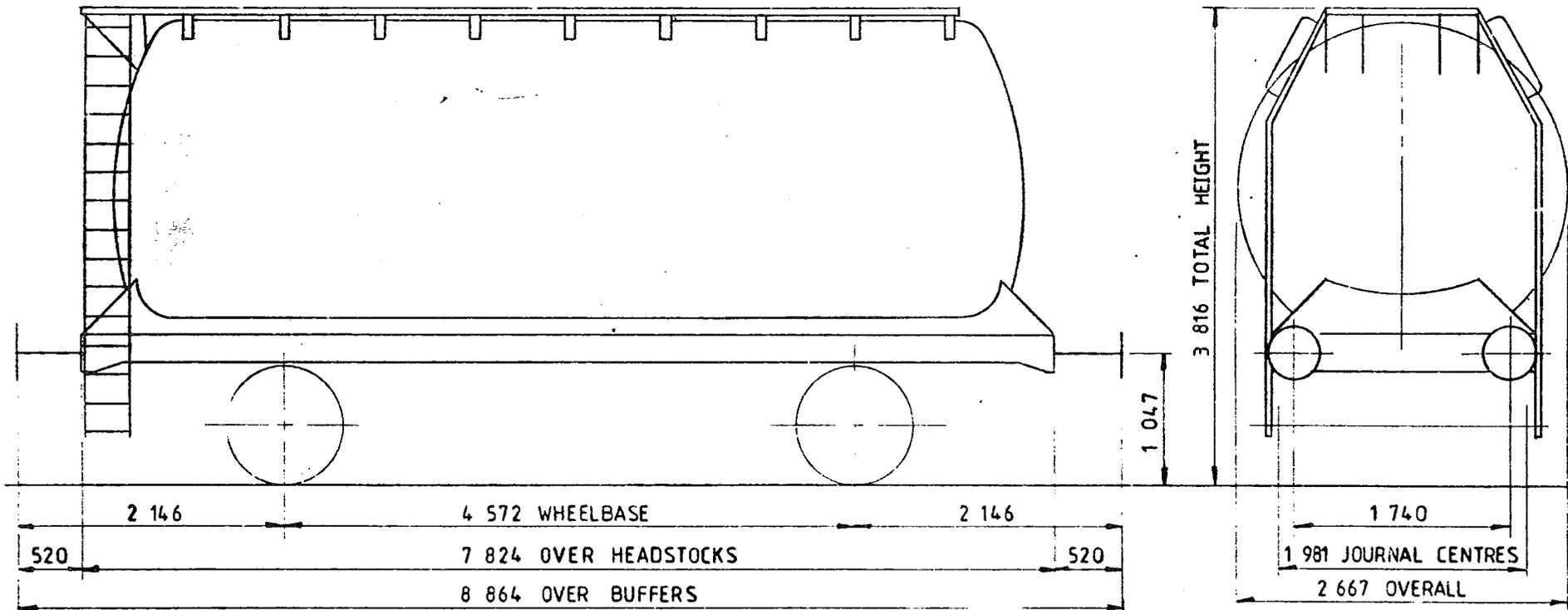

TARE	13 200 kg
CARRYING CAPACITY	32 800 kg
CAPACITY	18 502 litres
MAX SPEED	60 mile/h
WHEELS	952 DIA.
JOURNALS	140 DIA ROLLER BEARINGS

BUFFERS	HYDRAULIC, 406 DIA. HEADS
COUPLINGS	INSTANTER
MIN CURVE	31 m
GEN ARRGT DRG N°	
BRAKE	AIR BLOCK & HAND LEVER
SUSPENSION	4+1 PARABOLIC TAPERLEAF SPRINGS

issue 1

EX PO DIAGRAM 6/747 (ALLOCATED)

46 tonnes G.L.W. TANK WAGON - CLASS A.

TTO40A

EXCESS LENGTH	4	H	M	L	E
tonnes	46	46	14	14	
VB	0	0	0	0	
AB	23	23	8	8	
RA	8	6	1	1	
MAX SPEED	60	60	45	45	

TOPS CODE					
CARKND	AARKND	OPERATING PANEL No			
T	T	B	T	T	B A I 5 5 I

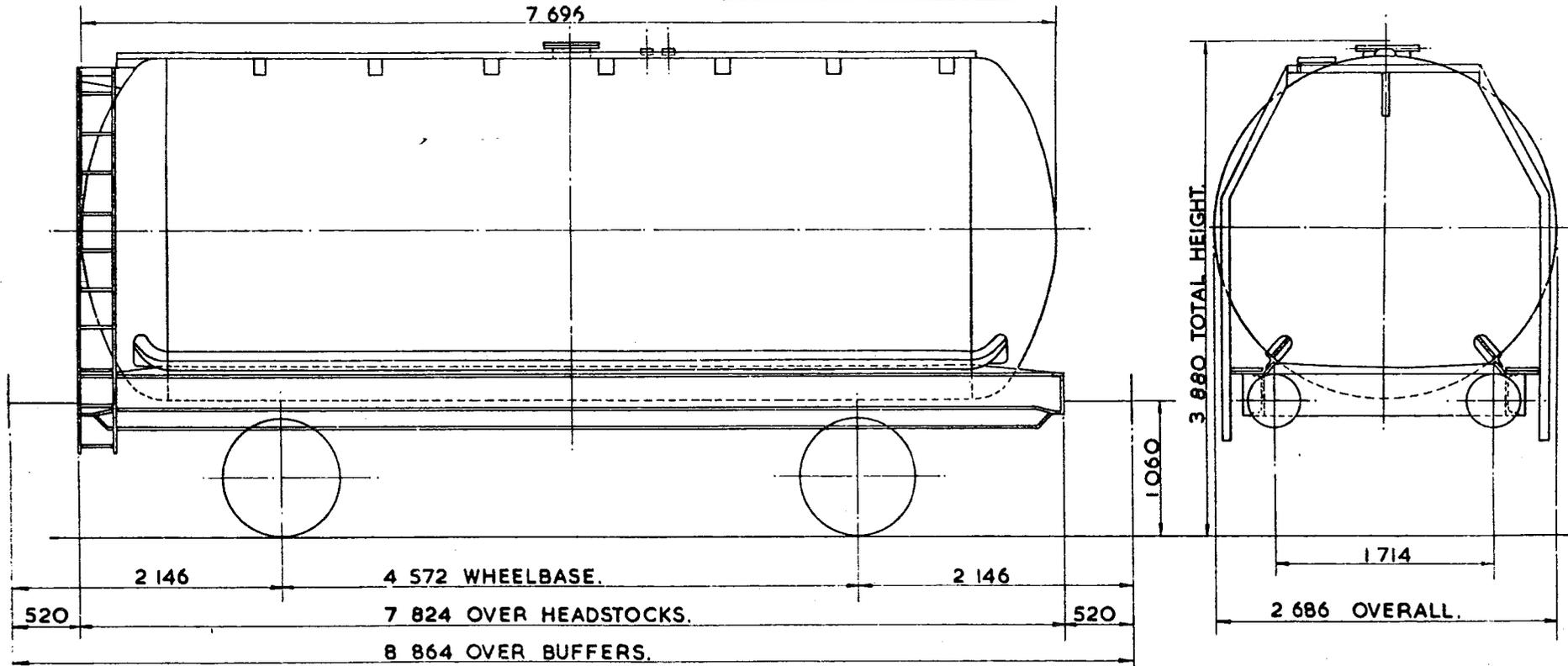

TARE -	13350 kg.
CARRYING CAPACITY -	32600 kg.
CAPACITY -	38414 & 39096 litres.
MAX. SPEED -	60 mile/h.
WHEELS -	952 DIA.
JOURNALS -	140 DIA. ROLLER BEARINGS.

BUFFERS -	HYDRAULIC 406 DIA. HEADS.
COUPLINGS -	INSTANTER.
MIN. CURVE -	26 m.
GEN. ARRGT. DRG. No. -	
BRAKE -	AIR BLOCK VACUUM PIPED & HAND LEVER.
SUSPENSION -	DOUBLE LINK.

BUILDER -	STANDARD RAILWAY WAGON Co.
OWNER -	V.I.P. PETROLEUM LTD.
REGISTERED BY -	C.M. & E.E. (B.R.B.) DERBY.
YEAR BUILT -	1966/67
REGISTRATION Nos. -	55201 TO 55244.
OWNERS Nos. -	001 TO 044.

ISSUE 2

EX. P.O. DIAGRAM 6/165 (ALLOCATED).

46 tonnes G.L.W. TANK WAGON

TTO40C

EXCESS LENGTH	H	M	L	E
4	46	46	13	13
tonnes	46	46	13	13
VB	0	0	0	0
AB	23	23	8	8
RA	8	8	1	1
MAX SPEED	60	60	60	60

TOPS CODE									
CARKND		AARKND							
T	T	B	T	B	A	1	5	9	7

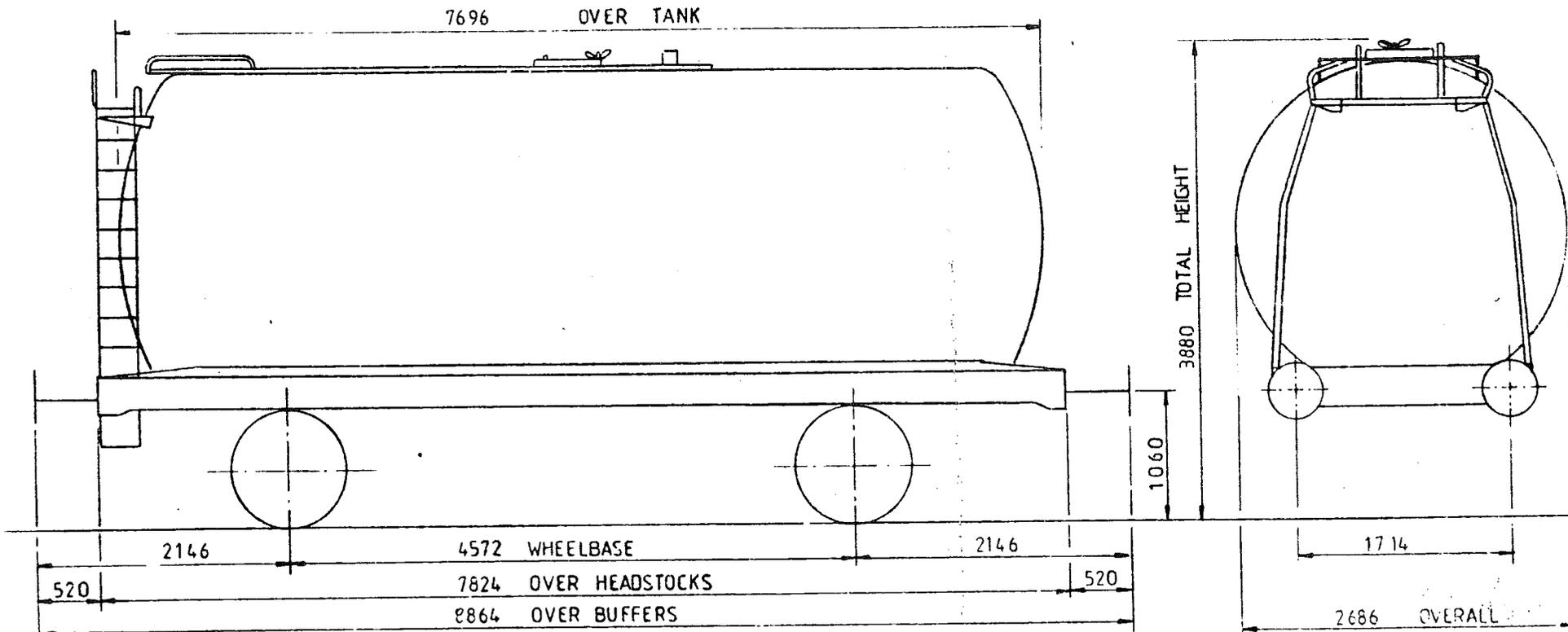

TARE	13350 kg
CARRYING CAPACITY	32600 kg
CAPACITY	24352 Litres
MAX SPEED	60 mile/h
WHEELS	φ 952
JOURNALS	φ140 ROLLER BEARINGS

BUFFERS	HYDRAULIC φ406 HEADS
COUPLINGS	INSTANTER
MIN CURVE	26m
GEN ARRGT DRG No	
BRAKE	AIR BLOCK, VAC PIPE & HAND LEVER
SUSPENSION	F.A.T. 26

ISSUE 1

46 tonne GLW TANK WAGON - CLASS A

LOT NUMBER	

TOPS INFORMATION						
AARKND	OPERATING	OPERATING SPEED		BRAKE FORCE DATA		EXCESS LENGTH
CARKND	PANEL No.	60 mile/h UP TO	46 tonne GLW	8 t FORCE UP TO	31 tonne GLW	RA (GLW)
T T A A		mile/h ABOVE		23 t FORCE ABOVE		4
						8
						DESIGN SHEET W1305

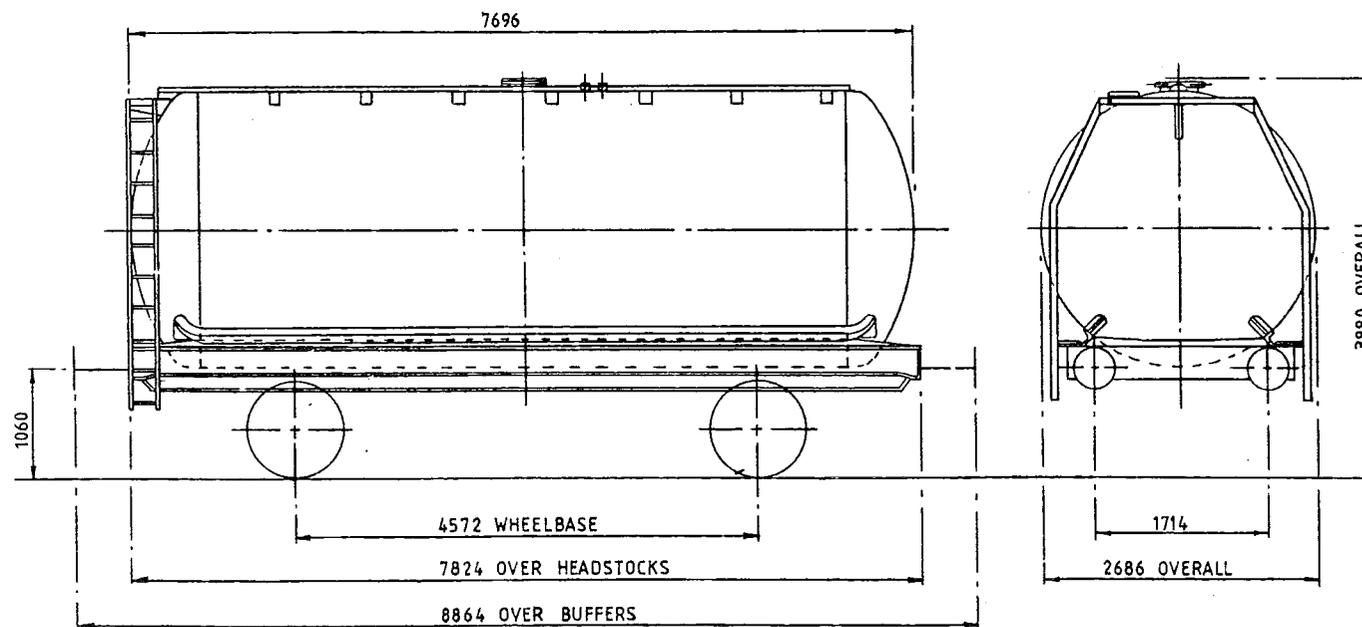

TARE-	12.650 Kg
CAPACITY, WEIGHT-	33.350 Kg
CAPACITY, VOLUME-	38.414 & 39.096 litres
MIN. CURVE-	26m
GEN. ARRGT. DRG. NO.-	

BRAKE-	AIR BLOCK & HAND LEVER
SUSPENSION-	DOUBLE LINK & PARABOLIC SPRING
COUPLINGS-	INSTANTER
BUFFERS-	HYDRAULIC 406 DIA HEADS
WHEELS-	952 DIA
JOURNALS-	140 DIA ROLLER BEARINGS

ISSUE 1

46 tonnes G.L.W. TANK WAGON.

TTO41A

EXCESS LENGTH	4	H	M	L	E
tonnes.	46	46	14	14	
VB	0	0	0	0	
AB	22	22	10	10	
RA	8	8	1	1	
MAX. SPEED	60	60	45	45	

TOPS CODE			
CARKND	AARKND	OPERATING PANEL No	
T	T	B	T
T	T	B	A
1	5	8	2

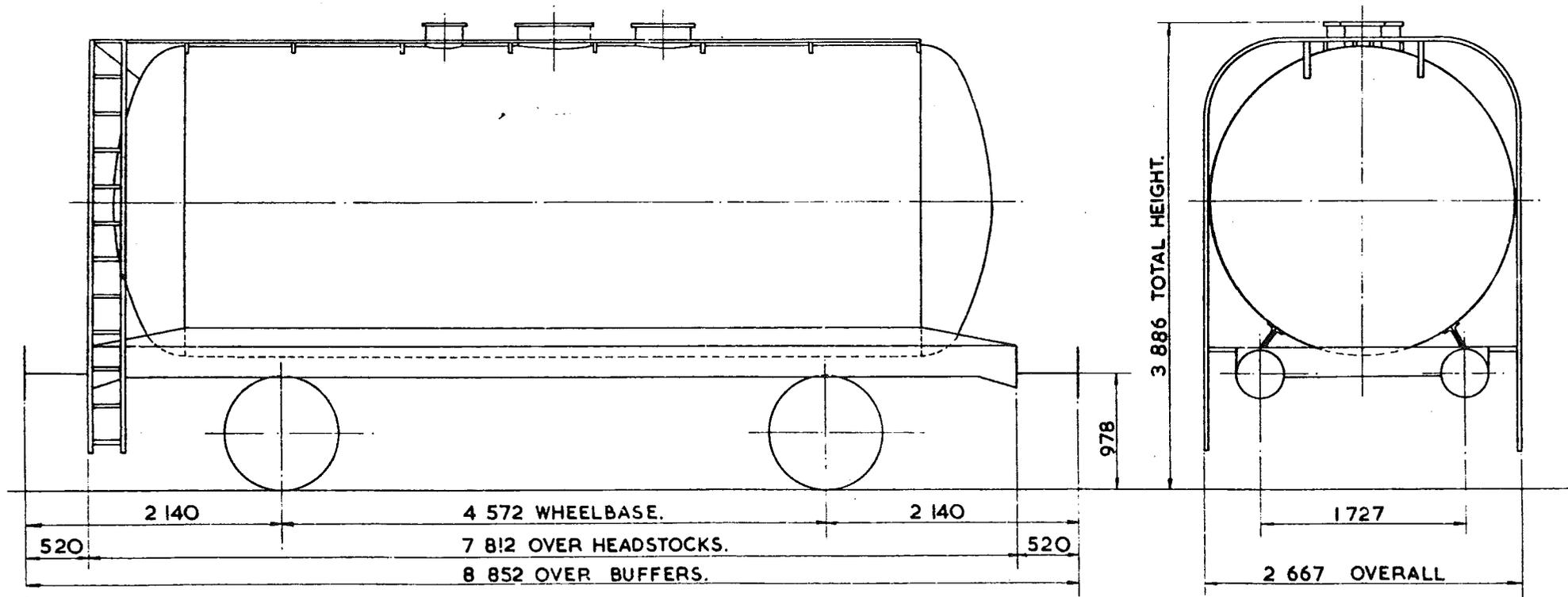

TARE - 14250kg.
CARRYING CAPACITY - 31700kg.
CAPACITY - 38641 litres.
MAX. SPEED - 60 mile/h.
WHEELS - 952 DIA.
JOURNALS - 140 DIA. ROLLER BEARINGS.

BUFFERS - HYDRAULIC 406 DIA. HEADS.
COUPLINGS - INSTANTER.
MIN. CURVE - 31m
GEN. ARRGT. DRG. No. -
BRAKE - AIR BLOCK, VACUUM PIPED, HAND LEVER.
SUSPENSION - DOUBLE LINK.

BUILDER - CHARLES ROBERTS.
OWNER - CHARRINGTON, GARDENER, LOCKET (LONDON) LTD.
REGISTERED BY - C.M. & E.E. (B.R.B.) DERBY.
YEAR BUILT - 1966
REGISTRATION Nos. - 53763 TO 53767.
OWNERS Nos. - 463 TO 467.

ISSUE 2

EX. P.O. DIAGRAM. 6/798 (ALLOCATED.)

46 tonnes G.L.W. TANK WAGON

TTO42B

EXCESS LENGTH	S	H	M	L	E
tonnes		46	46	14	14
VB		18	18	7	7
AB					
RA		8	8	1	1
MAX SPEED		60	60	45	45

TOPS CODE										
CARKND			AARKND			OPERATING PANEL NO.				
T	T	V	T	T	V	A	1	5	5	3

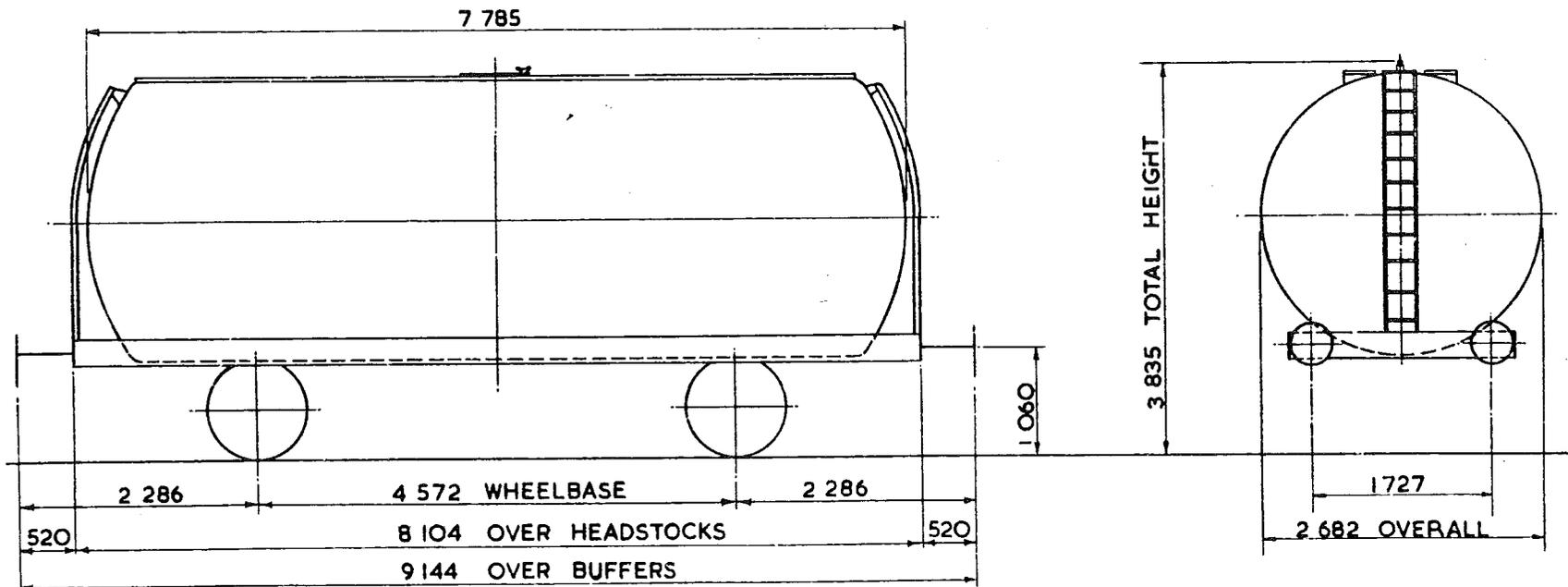

TARE - 13 700kg
CARRYING CAPACITY - 32 300kg
CAPACITY - 41 396 litres
MAX. SPEED - 60 mile/h.
WHEELS - 952 DIA.
JOURNALS - 140 DIA. ROLLER BEARINGS

BUFFERS - HYDRAULIC 406 DIA. HEADS.
COUPLINGS - INSTANTER
MIN CURVE - 31m.
GEN. ARRGT. DRG. No. -
BRAKE - VACUUM BLOCK & HAND LEVER.
SUSPENSION - DOUBLE LINK

BUILDER - CHARLES ROBERTS
OWNER - GULF OIL (G.B.) LTD.
REGISTERED BY - C.M.&E.E. (B.R.B.) DERBY.
YEAR BUILT - 1966
REGISTRATION Nos. - 54206 TO 54224
OWNERS Nos. - 007 TO 025

ISSUE 2
EX. P.O. DIAGRAM 6/146

46 tonne G.L.W. TANK WAGON - CLASS A

TTO42G

LOT NUMBER	

TOPS INFORMATION								
AARKND	OPERATING	OPERATING SPEED		BRAKE FORCE DATA		EXCESS LENGTH	RA (GLW)	DESIGN SHEET
CARKND	PANEL No.	45 mile/h UP TO	13.5 tonne GLW	7↑ FORCE UP TO	30.5 tonne G.L.W.	5	9	W864
T T A L		60 mile/h ABOVE		28↑ FORCE ABOVE				

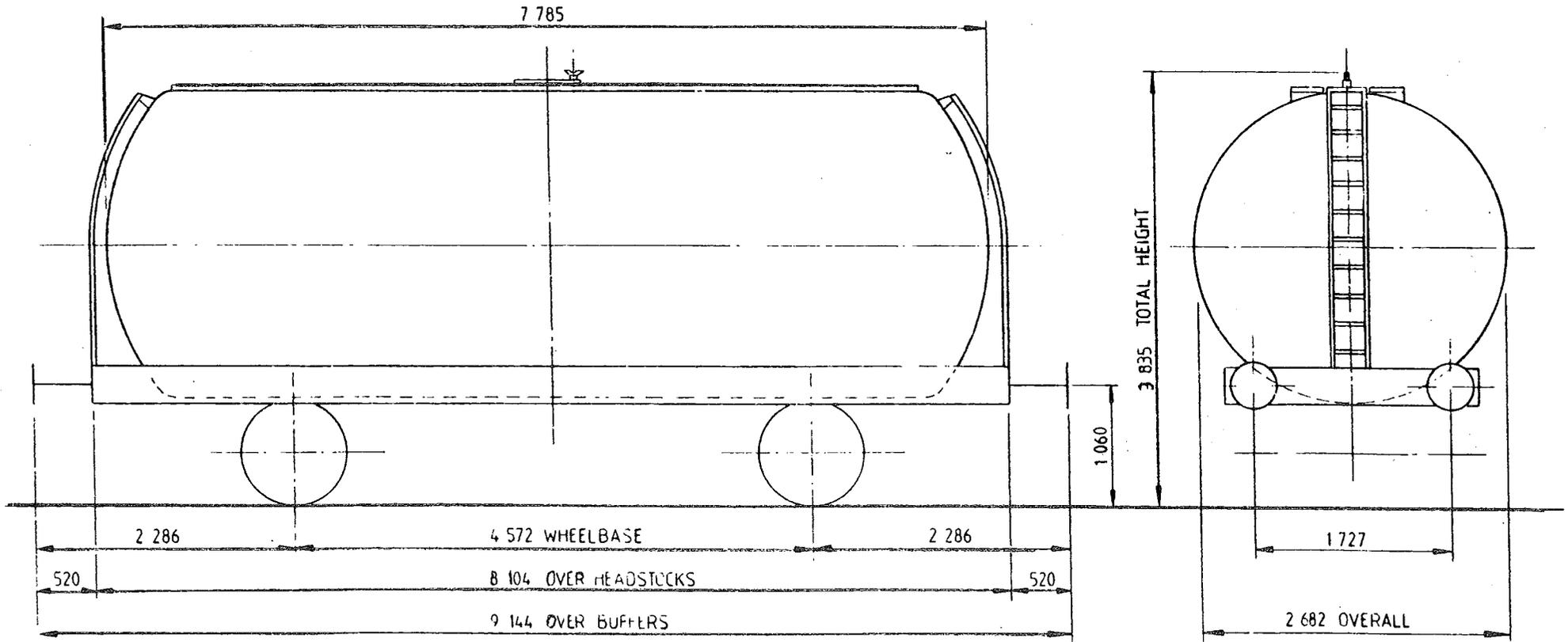

TARE-	13 500 kg
CAPACITY, WEIGHT-	32 500 kg
CAPACITY, VOLUME-	
MIN. CURVE-	31m
GEN. ARRGT. DRG. NO.-	

BRAKE-	AIR. BLOCK & HAND LEVER
SUSPENSION-	DOUBLE LINK
COUPLINGS-	INSTANTER
BUFFERS-	HYDRAULIC 400 DIA HEADS
WHEELS-	952 DIA
JOURNALS-	140 DIA ROLLER BEARINGS

ISSUE 1

LOT NUMBER	

TOPS INFORMATION										
AARKND		OPERATING		OPERATING SPEED		BRAKE FORCE DATA		EXCESS LENGTH	RA (GLW)	DESIGN SHEET
CARKND		PANEL No.		45 mile/h UP TO 60 mile/h ABOVE		71 FORCE UP TO 28t FORCE ABOVE				
T	T	A	A			13.3 tonne GLW	30.5 tonnes G.L.W.	5	9	W 899

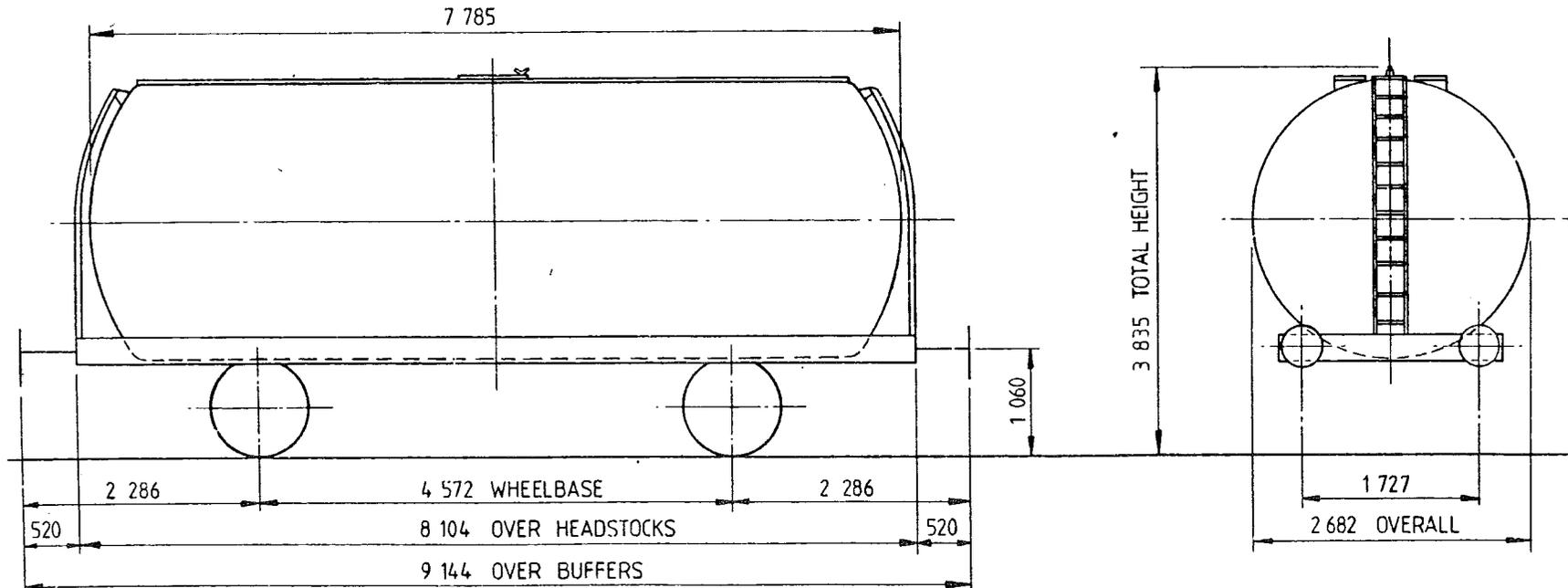

TARE-	13 300 kg
CAPACITY, WEIGHT-	32 700 kg
CAPACITY, VOLUME-	
MIN. CURVE-	31m
GEN. ARRGT. DRG. NO.-	

BRAKE-	AIR, BLOCK & HAND LEVER
SUSPENSION-	DOUBLE LINK
COUPLINGS-	INSTANTER
BUFFERS-	HYDRAULIC 406 DIA. HEADS
WHEELS-	952 DIA.
JOURNALS-	140 DIA. ROLLER BEARINGS

ISSUE 1.

46 tonne G.L.W. TANK WAGON - CLASS A

TTO42J

LOT NUMBER	

TOPS INFORMATION						
AARKND	OPERATING	OPERATING SPEED		BRAKE FORCE DATA		EXCESS LENGTH
CARKND	PANEL No.	45 mile/h UP TO	13.5 tonne GLW	7t FORCE UP TO	30.5 tonne G.L.W.	5
T T A 4		60 mile/h ABOVE		28t FORCE ABOVE		9
						W892

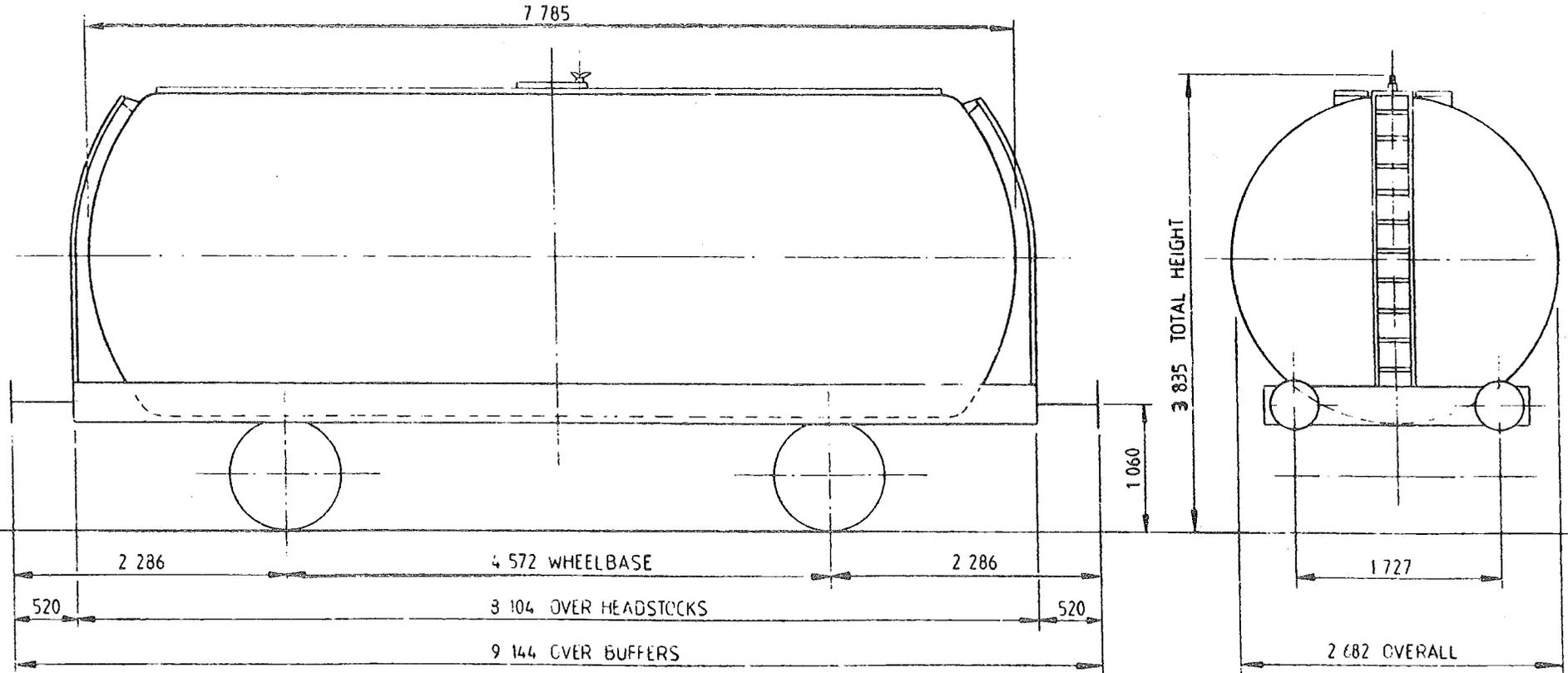

TARE-	13 500 kg
CAPACITY, WEIGHT-	32 500 kg
CAPACITY, VOLUME-	
MIN. CURVE-	31m
GEN. ARRGT. DRG. NO.-	

BRAKE-	AIR. BLOCK & HAND LEVER
SUSPENSION-	DOUBLE LINK
COUPLINGS-	INSTANTLER
BUFFERS-	HYDRAULIC 406 DIA HEADS
WHEELS-	952 LIA
JOURNALS-	140 LIA. ROLLER BEARINGS

ISSUE 1

46 tonne G.L.W. TANK WAGON - CLASS A

TTO42K

LOT NUMBER	

TOPS INFORMATION									
AARKND	OPERATING		OPERATING SPEED		BRAKE FORCE DATA		EXCESS LENGTH	RA (GLW)	DESIGN SHEET
CARKND	PANEL No.		60 mile/h UP TO	46 tonne GLW	7† FORCE UP TO	30.5 tonne G.L.W.	5	8	W1316
T T A A			mile/h ABOVE		28† FORCE ABOVE				

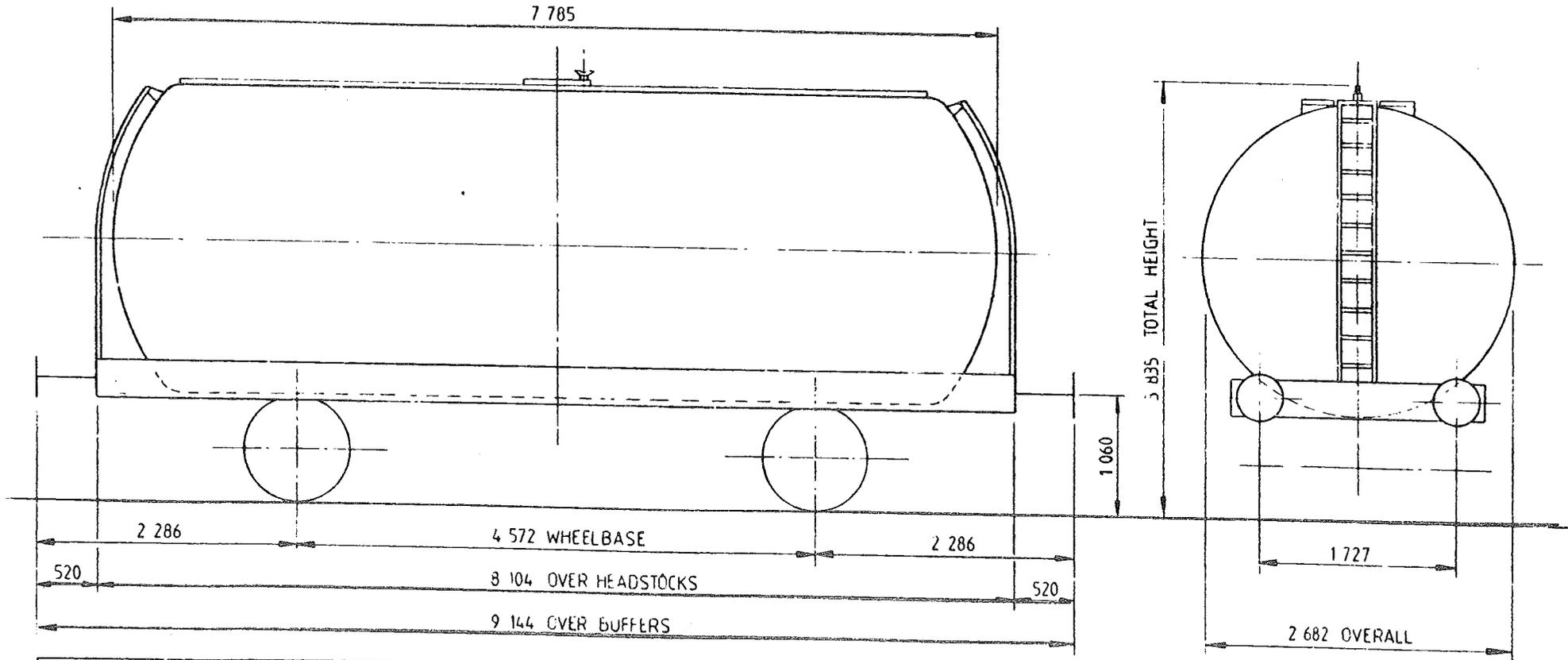

TARE-	13 500 kg
CAPACITY, WEIGHT-	32 500 kg
CAPACITY, VOLUME-	
MIN. CURVE-	31m.
GEN. ARRGT. DRG. NO.-	

BRAKE-	AIR BLOCK & HAND LEVER
SUSPENSION-	DOUBLE LINK & PARABOLIC SPRING
COUPLINGS-	INSTANTEP
BUFFERS-	HYDRAULIC 406 DIA HEADS
WHEELS-	952 DIA.
JOURNALS-	140 DIA. ROLLER BEARINGS

ISSUE 1

46 tonne G.L.W. TANK WAGON (CLASS 'A')

TTO42L

LOT NUMBER	

TOPS INFORMATION												
AARKND		OPERATING		OPERATING SPEED		BRAKE FORCE DATA		EXCESS LENGTH	RA (GLW)	DESIGN SHEET		
CARKND		PANEL No.		60 mile/h UP TO mile/h ABOVE		46 tonne GLW		7t FORCE UP TO 28t FORCE ABOVE	30.5 tonnes G.L.W.	5	9	W 1500
T	T	A	A									

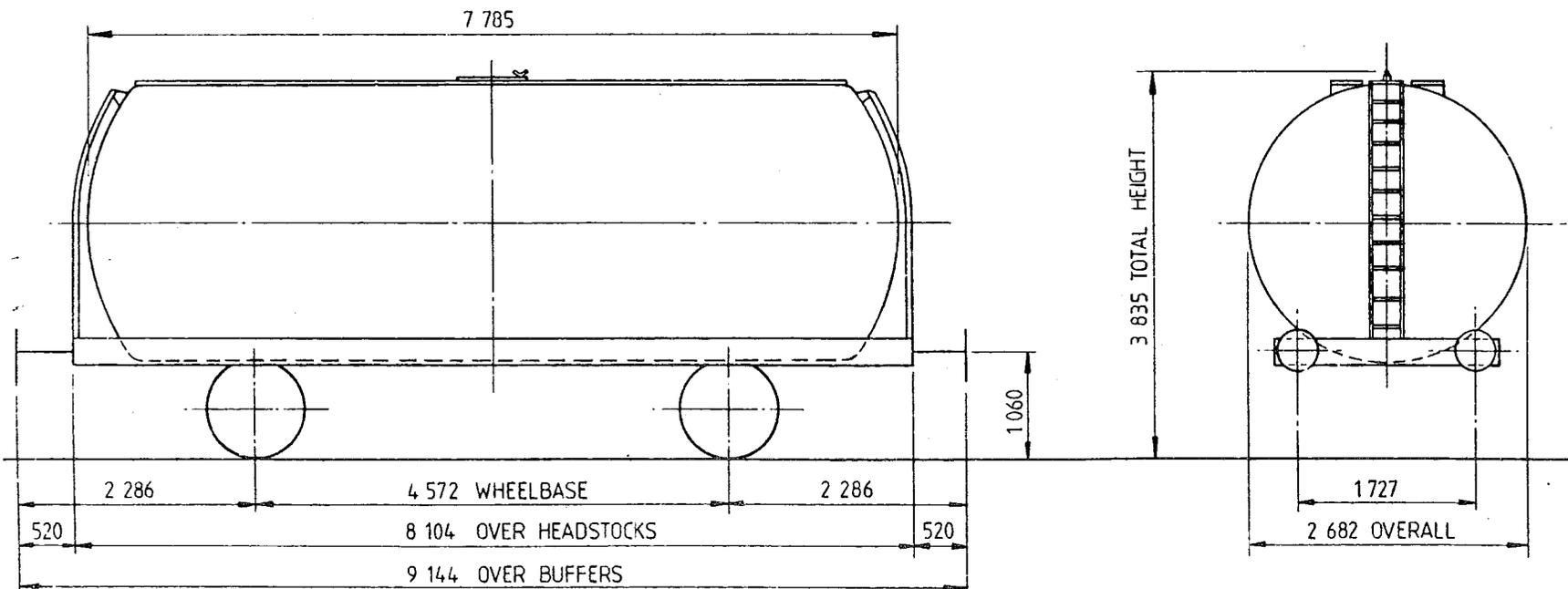

TARE-	13 100 kg
CAPACITY, WEIGHT-	32 900 kg
CAPACITY, VOLUME-	
MIN. CURVE-	31m
GEN. ARRGT. DRG. NO.-	

BRAKE-	AIR, BLOCK & HAND LEVER
SUSPENSION-	U.I.C. DOUBLE LINK + PARABOLIC TAPERLEAF SPRING
COUPLINGS-	INSTANTER
BUFFERS-	HYDRAULIC 406 DIA. HEADS
WHEELS-	952 DIA.
JOURNALS-	140 DIA. ROLLER BEARINGS

ISSUE 1.

46 tonne G.L.W. TANK WAGON (CLASS 'A')

TTO42M

LOT NUMBER	

TOPS INFORMATION													
AARKND		OPERATING		OPERATING SPEED			BRAKE FORCE DATA		EXCESS LENGTH	RA (GLW)	DESIGN SHEET		
CARKND		PANEL No.		60 mile/h UP TO mile/h ABOVE			46 tonne GLW		7t FORCE UP TO 28t FORCE ABOVE	30.5 tonne G.L.W.	5	9	W 1507
T	T	A	A										

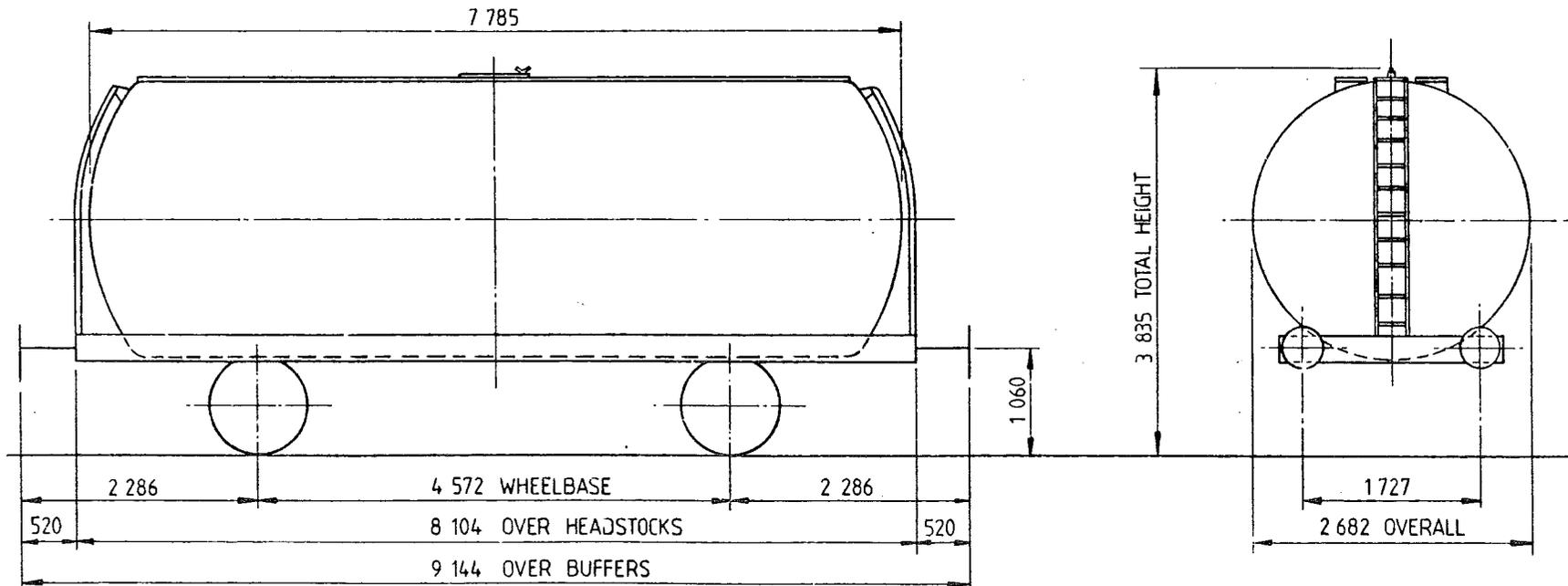

TARE-	13 050 kg
CAPACITY, WEIGHT-	32 950 kg
CAPACITY, VOLUME-	
MIN. CURVE-	31m
GEN. ARRGT. DRG. NO.-	

BRAKE-	AIR, BLOCK & HAND LEVER
SUSPENSION-	SINGLE FRICTION LINK & PARABOLIC TAPERLEAF SPRING
COUPLINGS-	INSTANTER
BUFFERS-	HYDRAULIC 406 DIA. HEADS
WHEELS-	952 DIA.
JOURNALS-	140 DIA ROLLER BEARINGS

ISSUE 1.

46 tonne G.L.W. TANK WAGON - CLASS A

TTO42N

LOT NUMBER	

TOPS INFORMATION								
AARKND	OPERATING	OPERATING SPEED		BRAKE FORCE DATA		EXCESS	RA	DESIGN
CARKND	PANEL No.	60 mile/h UP TO		7t FORCE UP TO		LENGTH	(GLW)	SHEET
T T A A		mile/h ABOVE		46 tonne GLW		5	9	W1674
				28t FORCE ABOVE				
				30.5 tonne G.L.W.				

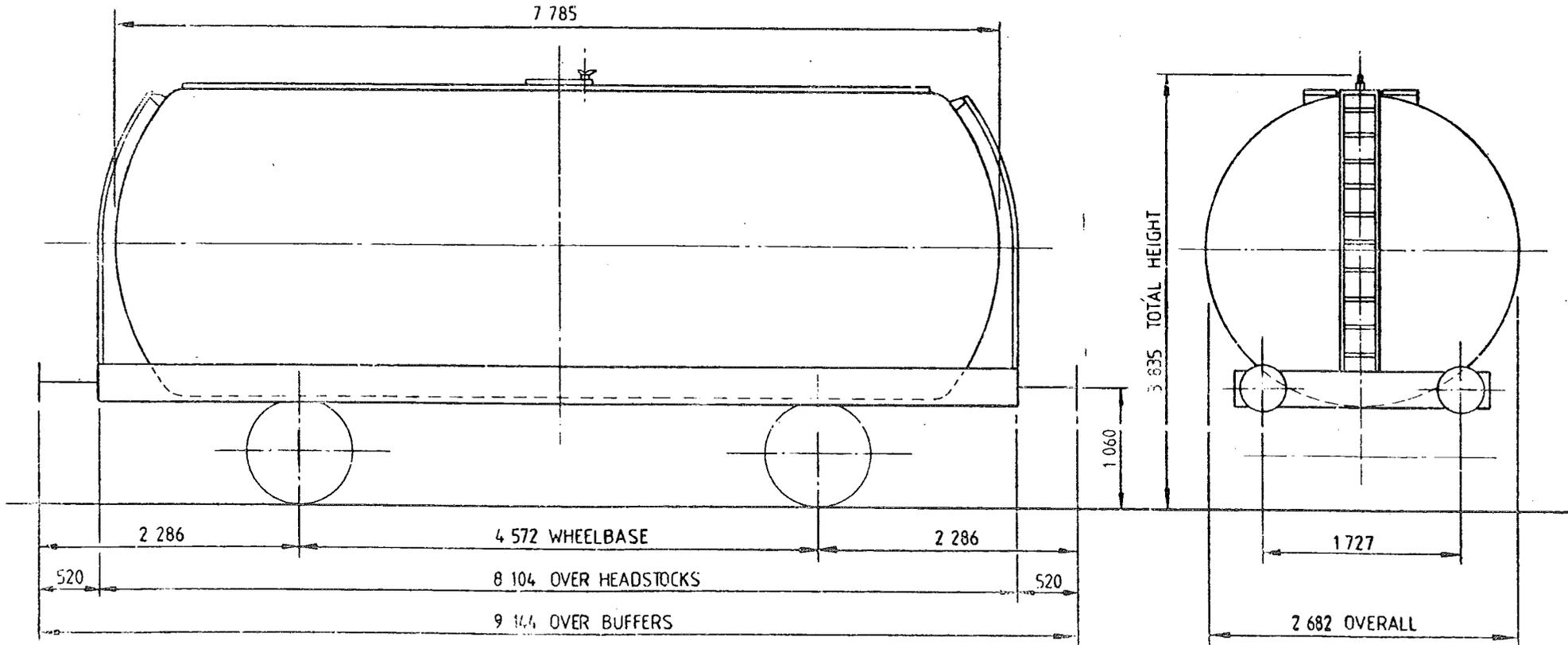

TARE-	13 500 kg
CAPACITY, WEIGHT-	32 500 kg
CAPACITY, VOLUME-	
MIN. CURVE-	31 m
GEN. ARRGT. DRG. NO.-	

BRAKE-	AIR. BLOCK & HAND LEVER
SUSPENSION-	PARABOLIC SPRING & B.R. SHORT SINGLE LINK
COUPLINGS-	INSTANTER
BUFFERS-	HYDRAULIC 406 DIA. HEADS
WHEELS-	952 DIA.
JOURNALS-	140 DIA ROLLER BEARINGS

ISSUE 1.

46 tonne G.L.W. TANK WAGON - CLASS A

TTO42P

LOT NUMBER	

TOPS INFORMATION											
AARKND		OPERATING		OPERATING SPEED			BRAKE FORCE DATA		EXCESS LENGTH	RA (GLW)	DESIGN SHEET
CARKND		PANEL No.		60 mile/h UP TO mile/h ABOVE			7t FORCE UP TO 20t FORCE ABOVE		5	9	W1675
T	T	A	A								

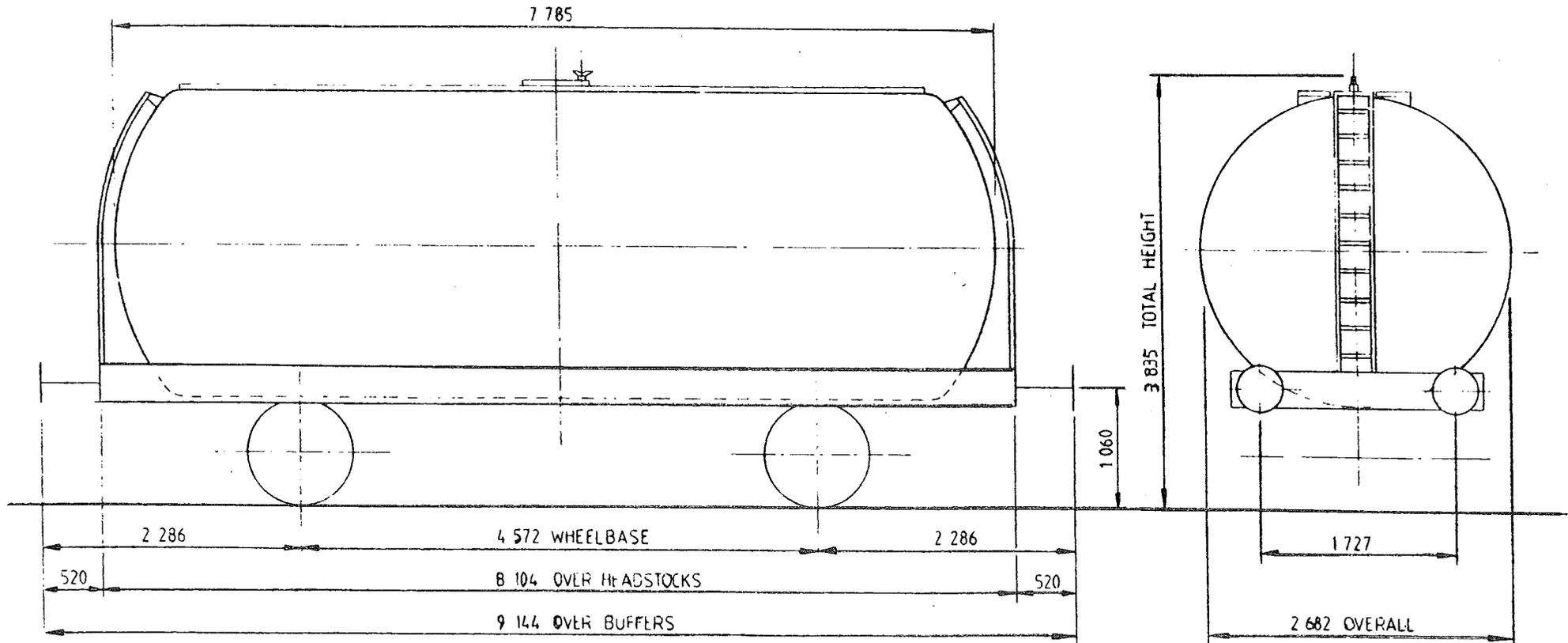

TARE-	13 500 kg
CAPACITY, WEIGHT-	32 500 kg
CAPACITY, VOLUME-	
MIN. CURVE-	31 m
GEN. ARRGT. DRG. NO.-	

BRAKE-	AIR BLOCK & HAND LEVER
SUSPENSION-	PARABOLIC SPRING & BR SHORT SINGLE LINK
COUPLINGS-	INSTANTER
BUFFERS-	HYDRAULIC 406 DIA HEADS
WHEELS-	952 DIA
JOURNALS-	140 DIA ROLLER BEARINGS

ISSUE 1

46 tonne G.L.W. TANK WAGON - CLASS A

TTO42Q

LOT NUMBER	

TOPS INFORMATION									
AARKND		OPERATING	OPERATING SPEED		BRAKE FORCE DATA		EXCESS LENGTH	RA (GLW)	DESIGN SHEET
CARKND		PANEL No.	60 mile/h UP TO mile/h ABOVE		46 tonne GLW 7t FORCE UP TO 28t FORCE ABOVE				
T	T	A	A						

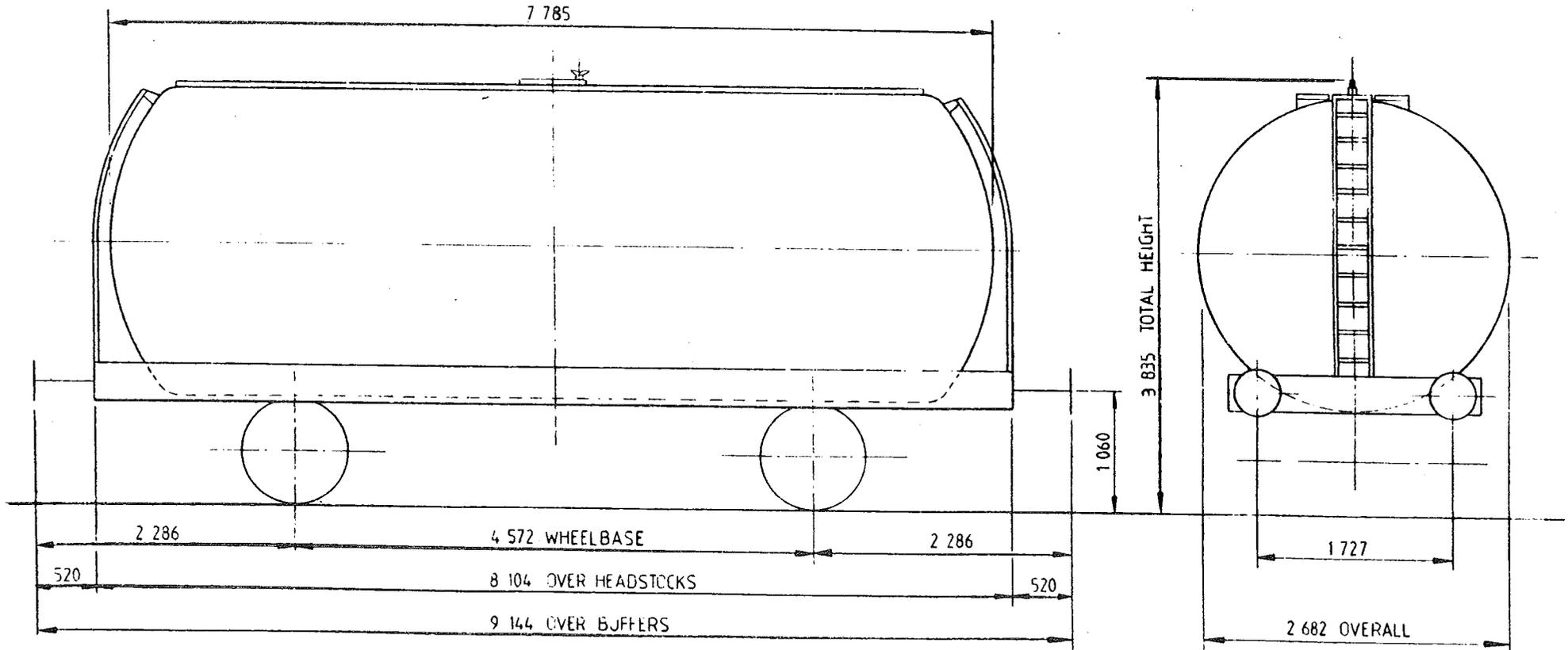

TARE-	13 500 kg
CAPACITY, WEIGHT-	32 500 kg
CAPACITY, VOLUME-	
MIN. CURVE-	31 m
GEN. ARRGT. DRG. NO.-	

BRAKE-	AIR. BLOCK & HAND LEVER
SUSPENSION-	PARABOLIC SPRING & B.R. SHORT SINGLE LINK
COUPLINGS-	WIPSTAITER
BUFFERS-	HYDRAULIC 406 DIA. HEADS
WHEELS-	952 DIA.
JOURNALS-	140 DIA. ROLLER BEARINGS

ISSUE 1

46 tonne G.L.W. TANK WAGON - CLASS A

TTO42 R

LOT NUMBER	

TOPS INFORMATION						
AARKND	OPERATING	OPERATING SPEED		BRAKE FORCE DATA		EXCESS LENGTH
CARKND	PANEL No.	60 mile/h UP TO	46 tonne GLW	7t FORCE UP TO	30.5 tonne G.L.W.	RA (GLW)
T T A A		mile/h ABOVE		28t FORCE ABOVE		5
						8
						DESIGN SHEET W1677

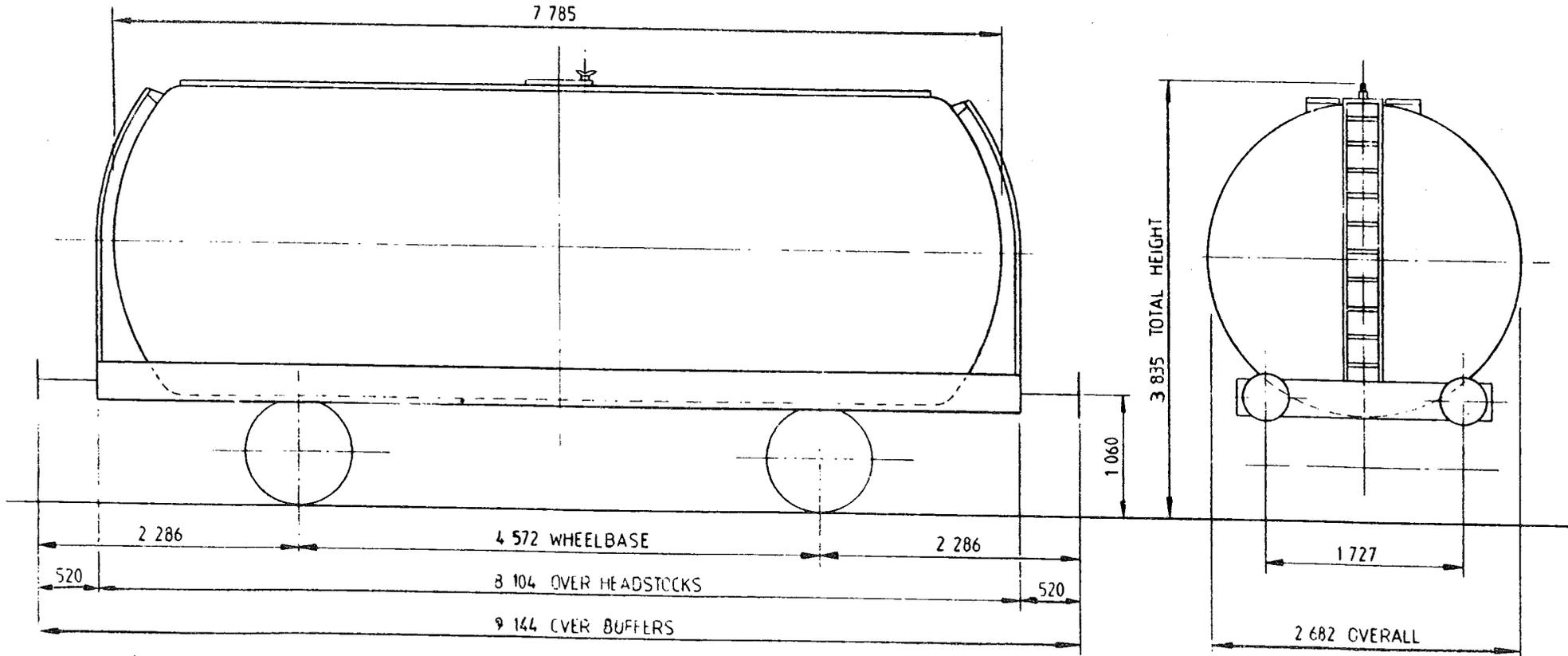

TARE-	13 500kg
CAPACITY, WEIGHT-	32 500kg
CAPACITY, VOLUME-	
MIN. CURVE-	31m
GEN. ARRGT. DRG. NO.-	

BRAKE-	AIR BLOCK & HAND LEVER
SUSPENSION-	PARABOLIC SPRING & B.R. SHORT SINGLE LINK
COUPLINGS-	INSTANTER
BUFFERS-	HYDRAULIC 406 DIA HEADS
WHEELS-	952 DIA
JOURNALS-	140 DIA ROLLER BEARINGS

ISSUE 1

46 tonne G.L.W. TANK WAGON - CLASS A

TTO42S

LOT NUMBER	

TOPS INFORMATION												
AARKND		OPERATING		OPERATING SPEED		BRAKE FORCE DATA		EXCESS LENGTH	RA (GLW)	DESIGN SHEET		
CARKND		PANEL No.		60 mile/h UP TO mile/h ABOVE		46 tonne GLW		7t FORCE UP TO 28t FORCE ABOVE	30.5tonne GLW	5	9	W1678
T	T	A	A									

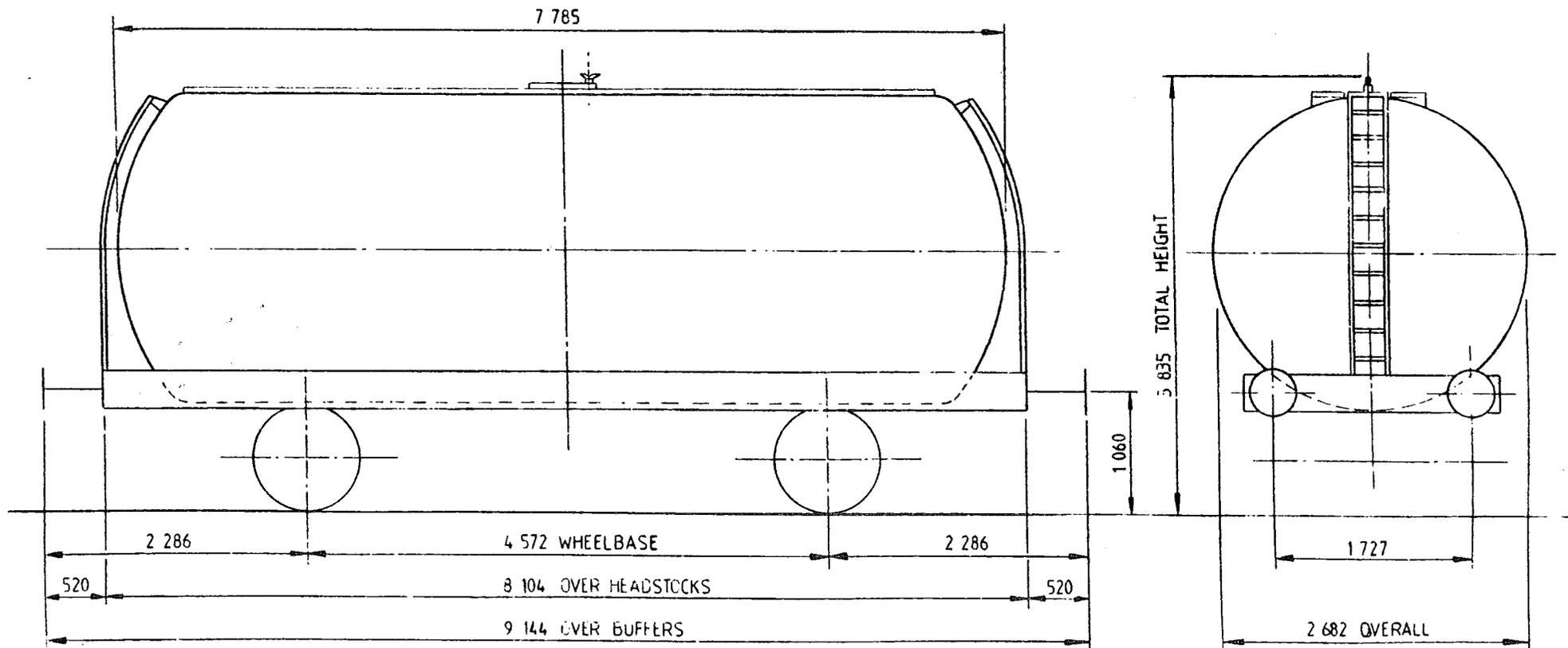

TARE-	13 000kg
CAPACITY, WEIGHT-	33 000kg
CAPACITY, VOLUME-	
MIN. CURVE-	31m
GEN. ARRGT. DRG. NO.-	

BRAKE-	AIR, BLOCK & HAND LEVER
SUSPENSION-	PARABOLIC SPRING & B.R. SHORT SINGLE LINK
COUPLINGS-	INSTANTER
BUFFERS-	HYDRAULIC 406 DIA. HEADS
WHEELS-	952 DIA.
JOURNALS-	140 DIA. ROLLER BEARINGS

ISSUE 1

46 tonnes G.L.W. TANK WAGON—CLASS 'A'

TTO43A

EXCESS LENGTH	5	H	M	L	E
tonnes	46	46	14	14	
VB	17	17	7	7	
AB					
RA	8	8	1	1	
MAX SPEED	60	60	45	45	

TOPS CODE										
CARKND			AARKND			OPERATING PANEL No				
T	T	F	T	T	F	A	I	5	4	9

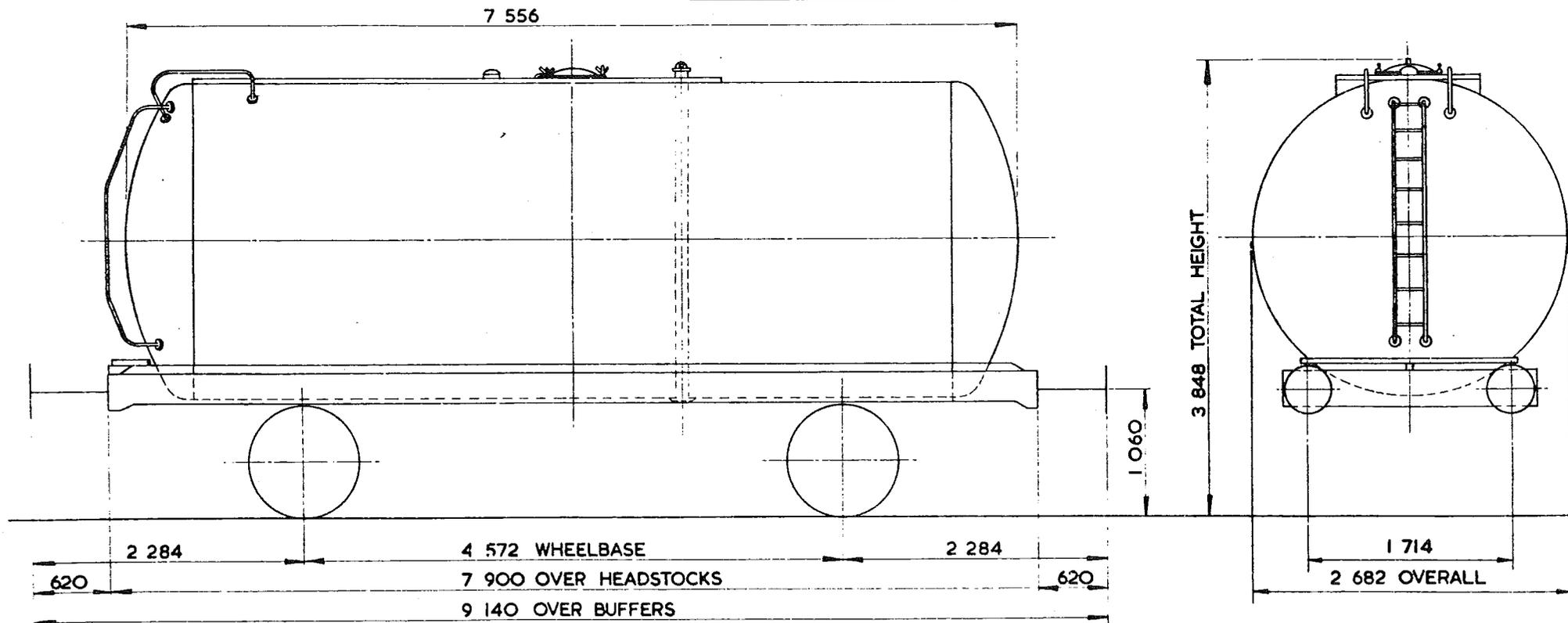

WEIGHT - 13 200 kg
CARRYING CAPACITY - 32 800 kg
CAPACITY - 38 186 litres
MAX SPEED - 60 mile/h
WHEELS - 952 DIA.
JOURNALS - 140 DIA ROLLER BEARINGS

BUFFERS - HYDRAULIC 406 DIA HEADS
COUPLINGS - INTERNATIONAL SCREW
MIN. CURVE - 31 m
GEN. ARRGT. DRG. No. -
BRAKE - VACUUM BLOCK & HAND LEVER
SUSPENSION - DOUBLE LINK

BUILDER - R.Y. PICKERING
OWNER - ALGECO
REGISTERED BY - C.M. & E.E. (B.R.B.) DERBY.
YEAR BUILT - 1965
REGISTRATION Nos. - 49104 to 49253
OWNERS Nos. - 1800 to 1979 (RANGE)

ISSUE 2

EX. PO. DIAGRAM 6/162

46 tonnes G.L.W. TANK WAGON-CLASS A

TTO43C

EXCESS LENGTH	5	H	M	L	E
tonnes.	46	46	14	14	
VB	19	19	8	8	
AD					
RA	8	8	1	1	
MAX. SPEED	60	60	45	45	

TOPS CODE										
CARKND			AARKND			OPERATING PANEL No				
T	T	F	T	T	F	A	I	5	4	8

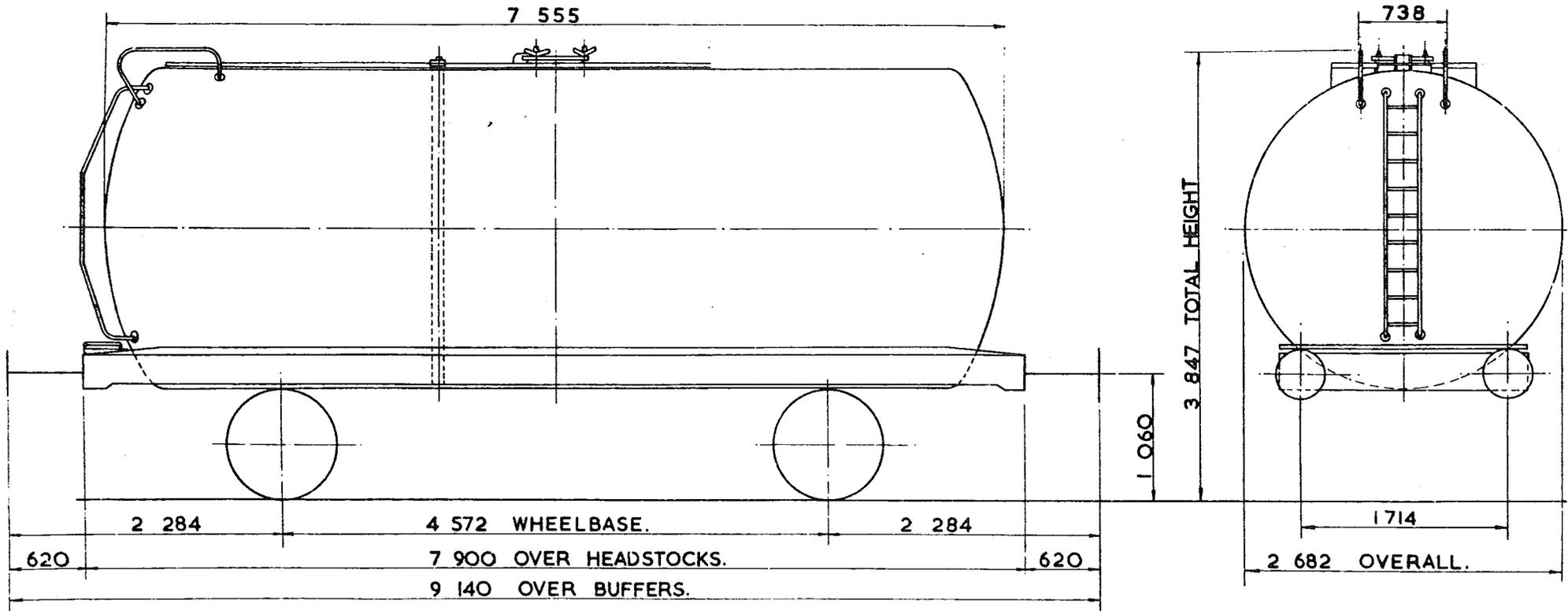

TARE - 13450kg.
CARRYING CAPACITY - 32500kg.
CAPACITY - 39709 litres.
MAX SPEED - 60 mile/h.
WHEELS - 952 DIA.
JOURNALS - 140 DIA. ROLLER BEARINGS.

BUFFERS - HYDRAULIC 406 DIA HEADS.
COUPLINGS - INTERNATIONAL SCREW.
MIN. CURVE - 31m.
GEN. ARRGT. DRG. No. -
BRAKE - VACUUM BLOCK & HAND LEVER.
SUSPENSION - DOUBLE LINK.

BUILDER - R.Y. PICKERING.
OWNER - BRITISH RAILWAY TRAFFIC & ELECTRIC.
REGISTERED BY - C.M. & E.E. (B.R.B.) DERBY.
YEAR BUILT - 1965.
REGISTRATION Nos. - 57246 TO 57294. (RANGE)
OWNERS Nos - 5925 TO 5974. (RANGE)

ISSUE 2

EX. P.O. DIAGRAM 6/154

46 tonnes G.L.W. TANK WAGON - CLASS A

TTO43E

EXCESS LENGTH 5	H	M	L	E
tonnes	46	46	13	13
VB				
AB	19	19	8	8
RA	8	8	1	1
MAX SPEED	60	60	45	45

TOPS CODE		
CARKND	AARKND	OPERATING PANEL No
T T A	T T A A	A I 5 5 9

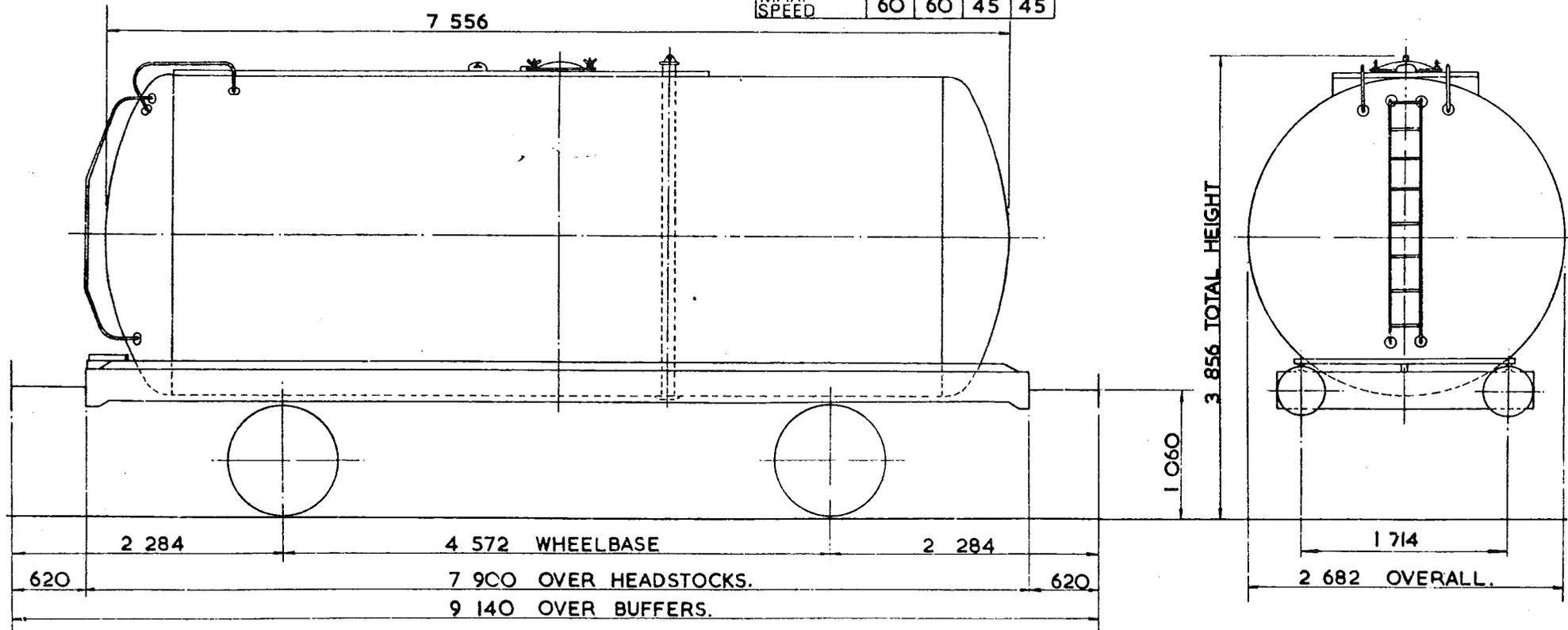

TARE - 13 450 kg.
CARRYING CAPACITY - 32 500 kg.
CAPACITY - 38 186 litres.
MAX. SPEED - 60 mile/h.
WHEELS - 952 DIA
JOURNALS - 140 DIA. ROLLER BEARINGS.

BUFFERS - HYDRAULIC 406 DIA. HEADS
COUPLINGS - INTERNATIONAL SCREW.
MIN. CURVE - 31m.
GEN. ARRGT. DRG. No -
BRAKE - AIR BLOCK & HAND LEVER
SUSPENSION - DOUBLE LINK.

BUILDER - R. Y. PICKERING.
OWNER - BRITISH RAILWAY TRAFFIC & ELECTRIC.
REGISTERED BY - C. M. & E. E. (B. R. B.) DERBY.
YEAR BUILT - 1967.
REGISTRATION Nos. - 57822 TO 57840.
OWNERS Nos. - 10472 TO 10490.

ISSUE 2

EX. P.O. DIAGRAM 6/158

46 tonnes G.L.W. TANK WAGON — CLASS A

TTO43F

EXCESS LENGTH	5	H	M	L	E
tonnes	46	46	14	14	
VB	18	18	8	8	
AB					
RA	8	8	1	1	
MAX. SPEED	60	60	45	45	

TOPS CODE										
CARKND			AARKND			OPERATING PANEL No.				
T	T	F	T	T	F	A	1	5	5	4

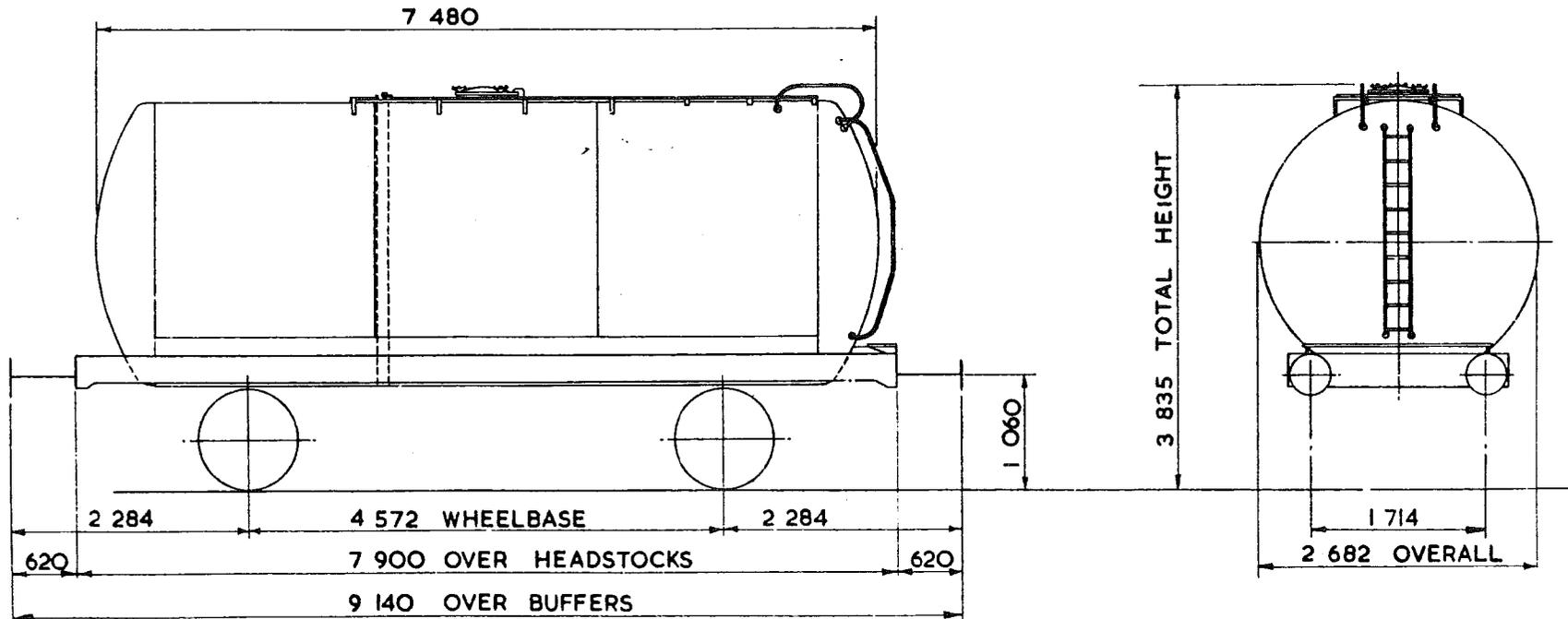

TARE - 13 700 kg
CARRYING CAPACITY - 32 300 kg
CAPACITY - 37 732 litres
MAX. SPEED - 60 mile/h
WHEELS - 952 DIA.
JOURNALS - 140 DIA. ROLLER BEARINGS

BUFFERS - HYDRAULIC 406 DIA. HEADS
COUPLINGS - INTERNATIONAL SCREW
MIN CURVE - 31m
GEN. ARRGT. DRG. No. -
BRAKE - VACUUM BLOCK & HAND LEVER
SUSPENSION - DOUBLE LINK

BUILDER - R.Y. PICKERING
OWNER - ESSO
REGISTERED BY - C.M.&E.E. (B.R.B.) DERBY
YEAR BUILT - 1965
REGISTRATION Nos. - 56000 TO 56103
OWNERS Nos. - 6000 TO 6103

ISSUE 2
EX. P.O. DIAGRAM 6/150

46 tonnes G.L.W. TANK WAGON - CLASS A

TTO43G

EXCESS LENGTH	5	H	M	L	E
tonnes	46	46	14	14	
VB	18	18	8	8	
AB					
RA	8	8	1	1	
MAX SPEED	60	60	45	45	

TOPS CODE										
CARKND		AARKND		OPERATING PANEL No						
T	T	F	T	T	F	A	1	5	5	4

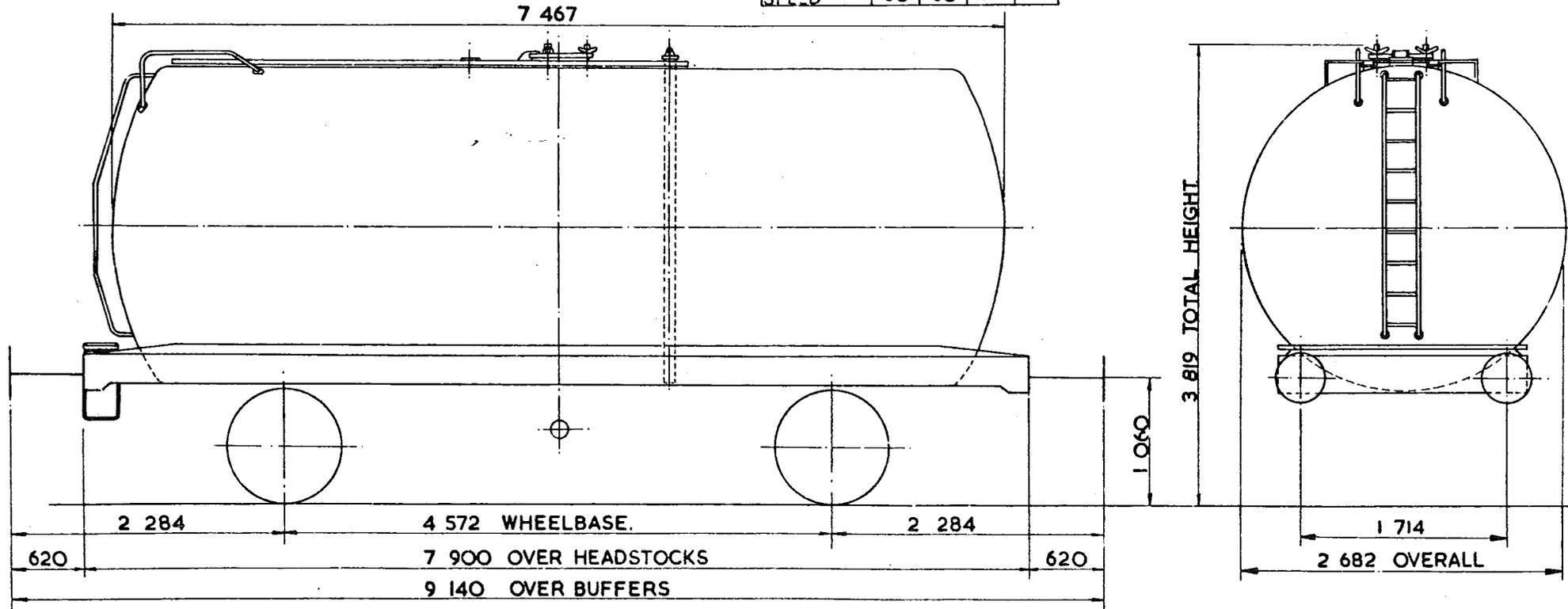

TARE - 13750kg.
CARRYING CAPACITY - 32200 kg
CAPACITY - 39322 litres
MAX. SPEED - 60mle/t.
WHEELS - 952 DIA.
JOURNALS - 140 DIA ROLLER BEARINGS.

BUFFERS - HYDRAULIC 406 DIA. HEADS
COUPLINGS - INTERNATIONAL SCREW.
MIN. CURVE - 31m
GEN. ARRG. DRG. No. -
BRAKE - VACUUM BLOCK & HAND LEVER
SUSPENSION - DOUBLE LINK.

BUILDER - POWELL DUFFRYN.
OWNER - ESSO.
REGISTERED BY - C.M. & E.E.(B.R.B)DERBY.
YEAR BUILT - 1965.
REGISTRATION Nos. - 56241 - 56281 (RANGE)
OWNERS Nos. - 6241 - 6281 (RANGE)

ISSUE 2
EX. P.O. DIAGRAM 6/151.

46 tonnes G.L.W. TANK WAGON-CLASS A - CLOSE COUPLED.

TTO43J

EXCESS LENGTH	4	H	M	L	E
tonnes	46	46	14	14	
VB	0	0	0	0	
AB	22	22	10	10	
RA	8	8	1	1	
MAX SPEED	60	60	45	45	

TOPS CODE		
CARKND	AARKND	OPERATOR
T T B T T B A 1 5 8 2		

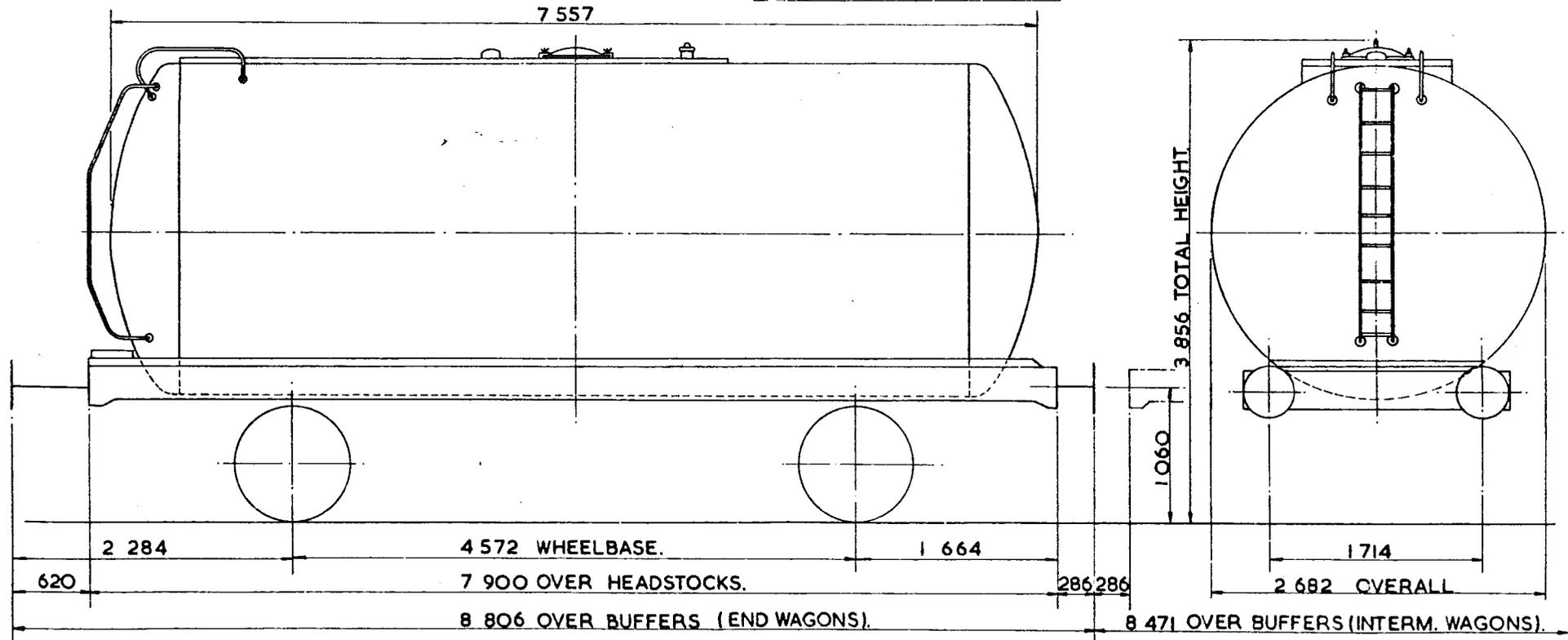

TARE	13 400kg
CARRYING CAPACITY	32500kg
CAPACITY	38186 litres.
MAX SPEED	60mile/h.
WHEELS	952 DIA.
JOURNALS	140 DIA. ROLLER BEARINGS.

BUFFERS	HYDRAULIC 406 DIA. HEADS.
COUPLINGS	INTERNATIONAL SCREW & CLOSE COUPLED.
MIN CURVE	31m.
GEN ARPGT DRG No.	
BRAKE	AIR BLOCK, VACUUM PIPE & HAND LEVER
SUSPENSION	DOUBLE LINK.

BUILDER	R.Y. PICKERING CO. LTD.
OWNER	B.R.T. & E.
REGISTERED BY	C.M. & E.E. (B.R.B.) DERBY
YEAR BUILT	1967.
REGISTRATION Nos.	57478 & 57479
OWNERS Nos.	10128 & 10129,

ISSUE 2

EX. P.O. DIAGRAM 6/214

46 tonnes G.L.W. TANK WAGON

TT O43K

LOT NUMBER	

TOPS INFORMATION														
AARKND		OPERATING		OPERATING SPEED			BRAKE FORCE DATA		EXCESS LENGTH	RA (GLW)	DESIGN SHEET			
CARKND		PANEL No.		45	mile/h UP TO		8t FORCE UP TO		5	8	DESIGN SHEET			
T	T	F	A	1	5	5	4	60				13.7 tonne GLW		18t FORCE OVER

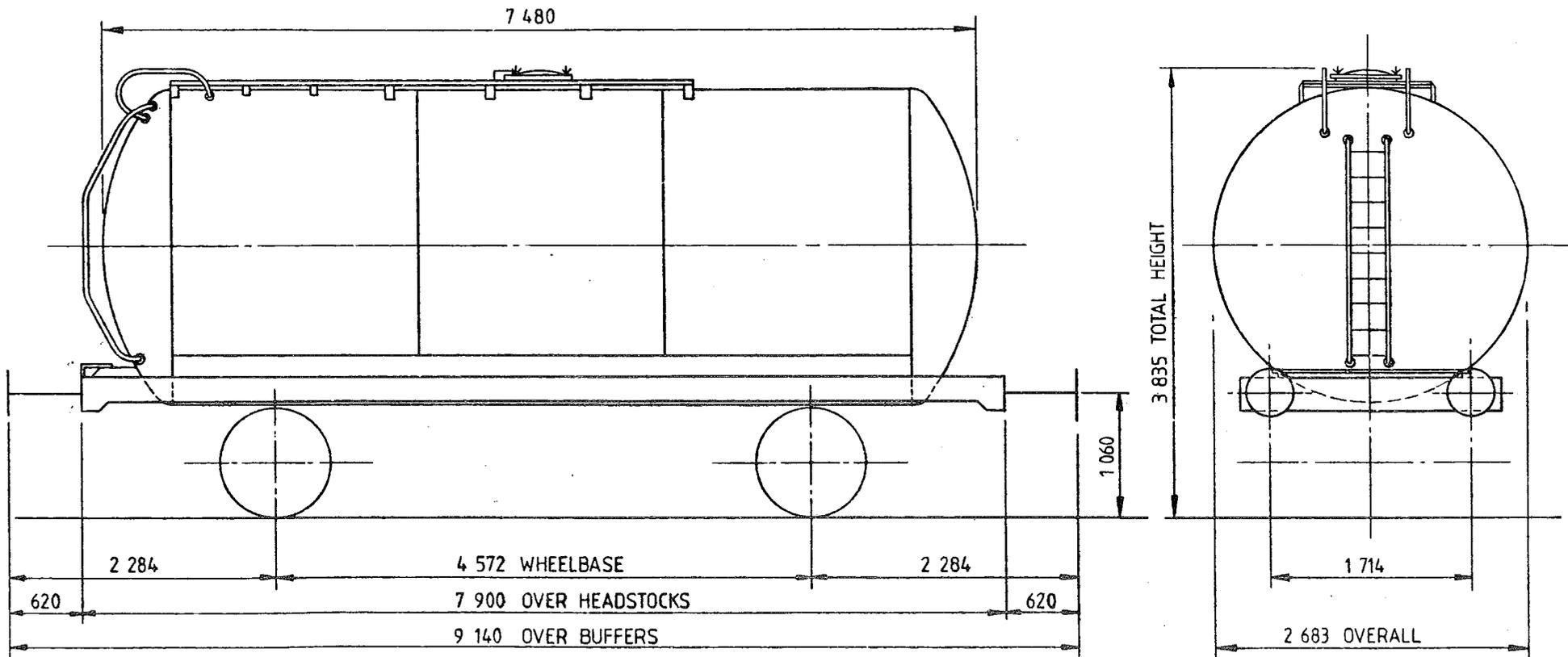

TARE-	13 700 kg
CAPACITY, WEIGHT-	32 300 kg
CAPACITY, VOLUME-	37 732 litres
MIN. CURVE-	31 m
GEN. ARRGT. DRG. NO.-	

BRAKE-	VACUUM BLOCK & HAND LEVER
SUSPENSION-	DOUBLE LINK
COUPLINGS-	INTERNATIONAL SCREW
BUFFERS-	HYDRAULIC 406 DIA. HEADS
WHEELS-	952 DIA
JOURNALS-	140 DIA ROLLER BEARINGS

ISSUE 3
EX. P.O. DIAGRAM 6/215

46 tonnes G.L.W. TANK WAGON - CLASS A - CLOSE COUPLED

TTO43L

EXCESS LENGTH	4	H	M	L	E
tonnes	46	46	14	14	
VB					
AB	22	22	10	10	
RA	8	8	1	1	
MAX SPEED	60	60	45	45	

TOPS CODE									
CARKND		AARKND			OPERATING PANEL No.				
T	T	A	T	A	A	I	5	4	7

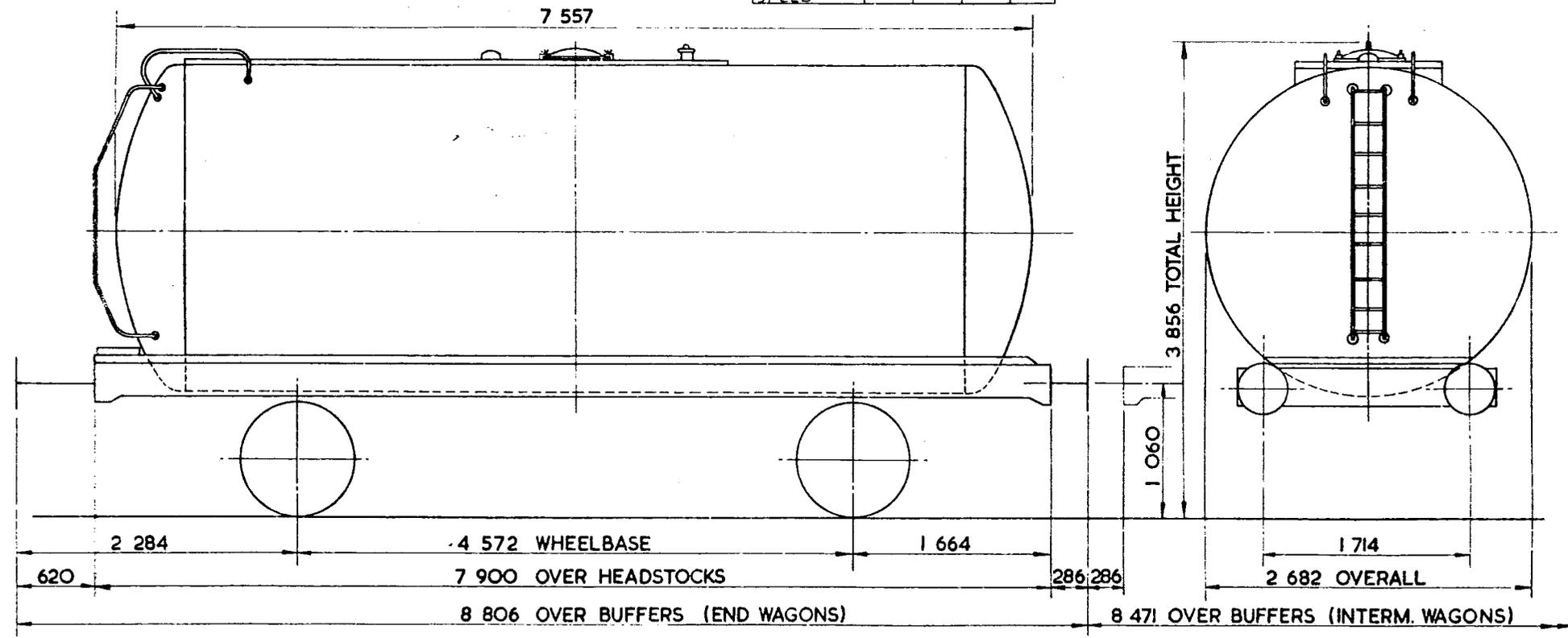

TARE -	13 450 kg
CARRYING CAPACITY -	32 500 kg
CAPACITY -	38 186 litres
MAX. SPEED -	60 mile/h
WHEELS -	952 DIA.
JOURNALS -	140 DIA. ROLLER BEARINGS

BUFFERS -	HYDRAULIC 406 DIA. HEADS.
COUPLINGS -	INTERNATIONAL SCREW & CLOSE COUPLED.
MIN. CURVE -	31m.
GEN. ARRGT. DRG No. -	
BRAKE	AIR BLOCK & HAND LEVER
SUSPENSION	DOUBLE LINK

BUILDER -	R.Y. PICKERING CO. LTD.
OWNER -	BRITISH RAILWAYS TRAFFIC & ELECTRIC LTD.
REGISTERED BY -	C.M. & E.E. (B.R.B.) DERBY.
YEAR BUILT -	1967
REGISTRATION Nos. -	57484 - 57576 (RANGE).
OWNERS Nos. -	

ISSUE 2

EX. P.O. DIAGRAM 6/214

46 tonnes G.L.W. TANK WAGON CLASS A

TT043N

EXCESS LENGTH	4	H	M	L	E
tonnes	46	46	14	14	
VB	0	0	0	0	
AB	22	22	10	10	
BA	8	8	1	1	
MAY SPEED	60	60	45	45	

TOPS CODE					
CARKND	AARKND	CLASS	TYPE	NO.	...
T	T	B	T	B	A
1	4	7	3		

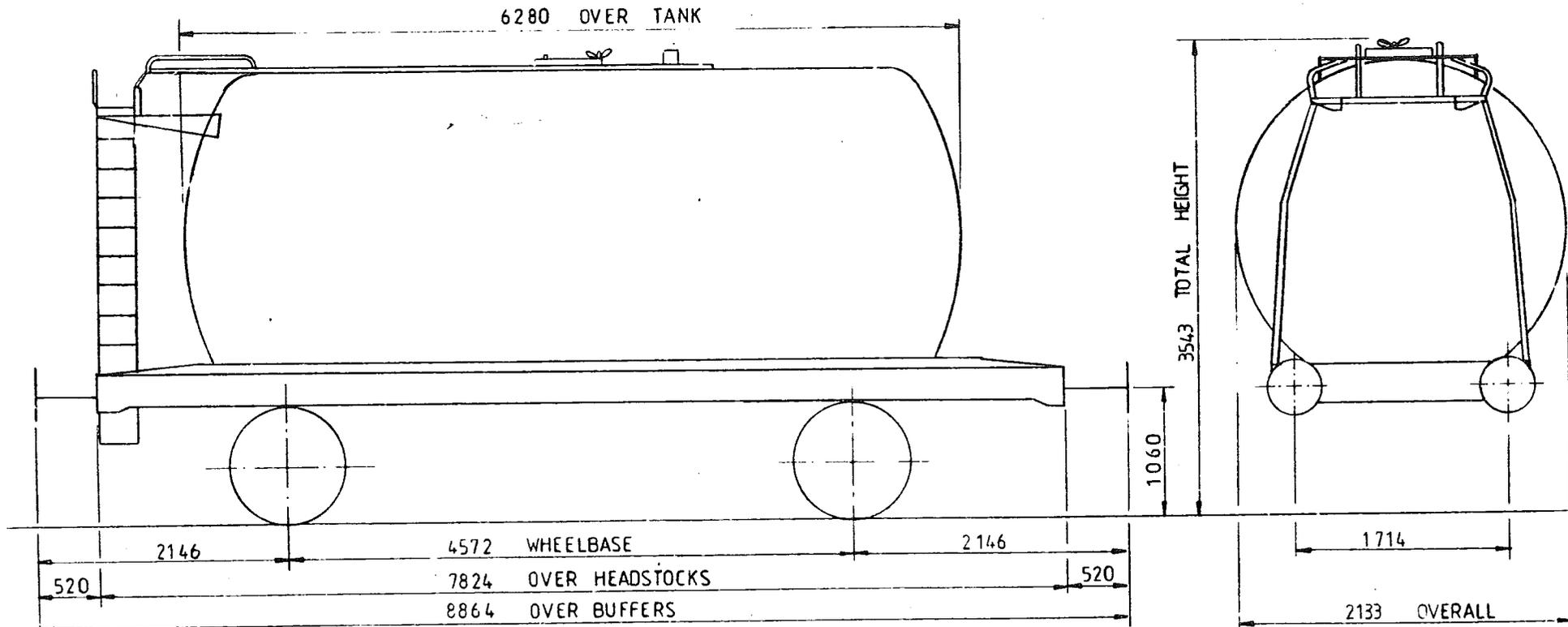

TARE	14 000 kg
CARRYING CAPACITY	31 500 kg
CAPACITY	39732 Litres
MAX SPEED	60 mile/h
WHEELS	φ 952
JOURNALS	φ140 ROLLER BEARINGS

BUFFERS	HYDRAULIC φ406 HEADS
COUPLINGS	INSTANTER
MIN CURVE	31 m
GEN ARRGT DRG No	
BRAKE	AIR BLOCK, VAC PIPE, HAND LEVER.
SUSPENSION	DOUBLE LINK

ISSUE 1

46 tonne GLW TANK WAGON-CLASS A CLOSE COUPLED

TT043P

EXCESS LENGTH	H	M	L	E
4 tonnes	46	46	14	14
VB				
AB	20	20	9	9
RA	8	8	1	1
MAX SPEED	60	60	60	60

TOPS CODE									
CARKND	AARKND		OPERATION POINTS						
T	T	A	T	A	A	8	9	5	7

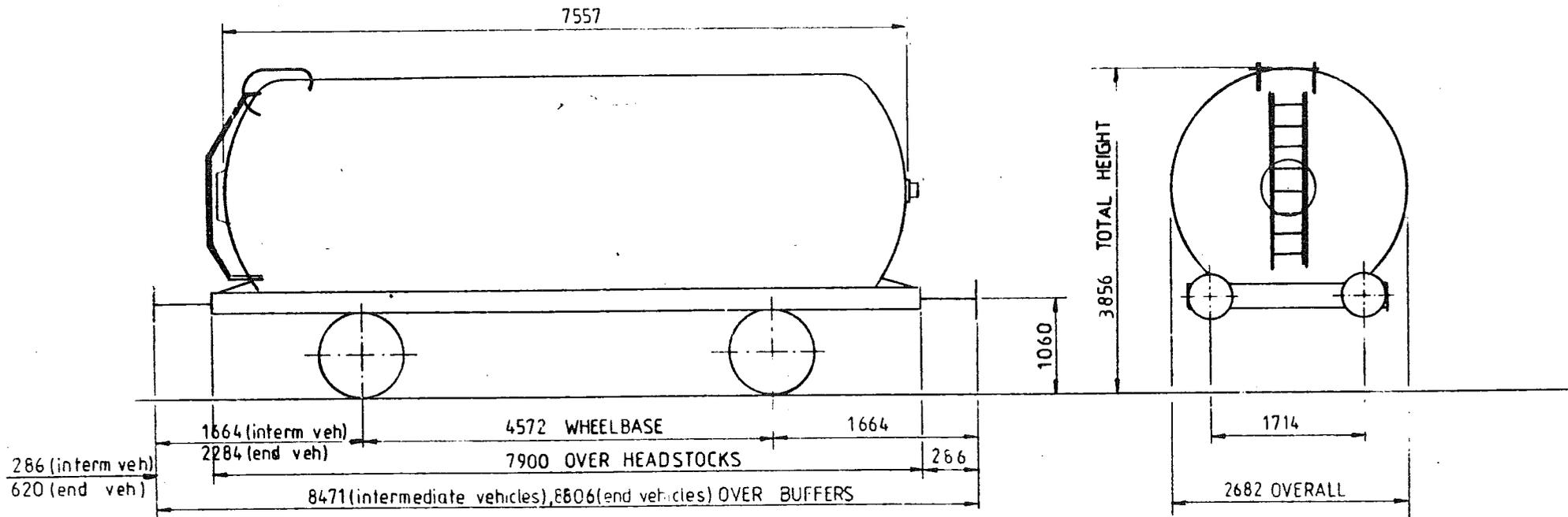

TARE	13.50	kg
CARRYING CAPACITY	32.500	kg
CAPACITY	38186	Litres
MAX SPEED	60	mile/h
WHEELS	φ 952	
JOURNALS	φ 140	ROLLER BEARINGS

BUFFERS	HYDRAULIC	φ 406	HEADS
COUPLINGS	INSTANTER		
MIN CURVE	31m		
GEN ARRG T DRG No			
BRAKE	AIR BLOCK,	HAND LEVER	
SUSPENSION	FAT 26		

ISSUE 1

EX PO. DIAGRAM 6/214

46 tonne GLW TANK WAGON - CLASS A

LOT NUMBER	

TOPS INFORMATION									
AARKND	OPERATING		OPERATING SPEED		BRAKE FORCE DATA		EXCESS LENGTH	RA (GLW)	DESIGN SHEET
CARKND	PANEL No.		60 mile/h UP TO	46 tonne GLW	5 t FORCE UP TO	30.5 tonne GLW	5	9	W 927
T T A A			mile/h ABOVE		24 t FORCE ABOVE				W 928
									W 1168

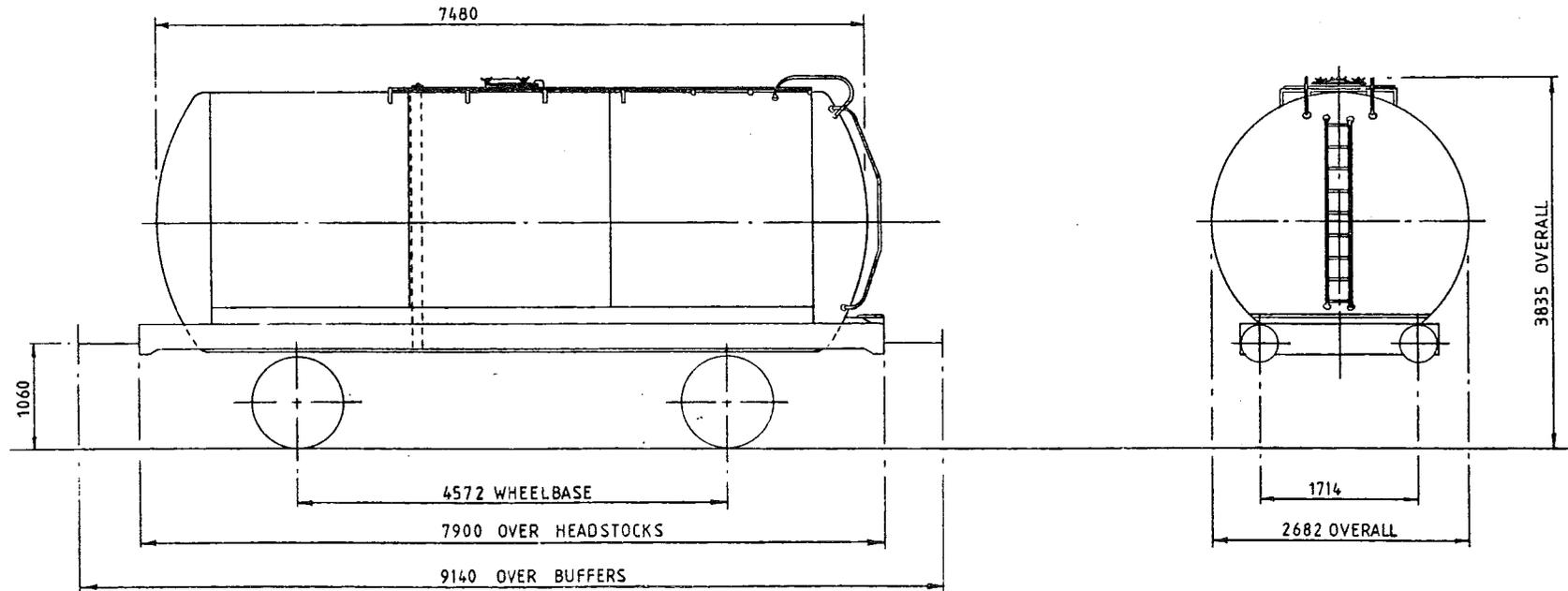

TARE-	13.000 Kg
CAPACITY, WEIGHT-	33.000 Kg
CAPACITY, VOLUME-	37.732 litres
MIN. CURVE-	31m
GEN. ARRGT. DRG. NO.-	

BRAKE-	AIR BLOCK & HAND LEVER
SUSPENSION-	DOUBLE LINK & PARABOLIC SPRING
COUPLINGS-	INTERNATIONAL SCREW
BUFFERS-	HYDRAULIC 406 DIA HEADS
WHEELS-	952 DIA
JOURNALS-	140 DIA ROLLER BEARINGS

ISSUE 1

46 tonne GLW TANK WAGON - CLASS 'A'

LOT NUMBER	

TOPS INFORMATION						
AARKND	OPERATING	OPERATING SPEED		BRAKE FORCE DATA		EXCESS LENGTH
CARKND	PANEL No.	60 mile/h UP TO	46 tonne GLW	7t FORCE UP TO	30.5 tonne GLW	RA (GLW)
T T A A		mile/h ABOVE		28t FORCE ABOVE		DESIGN SHEET
						W 926

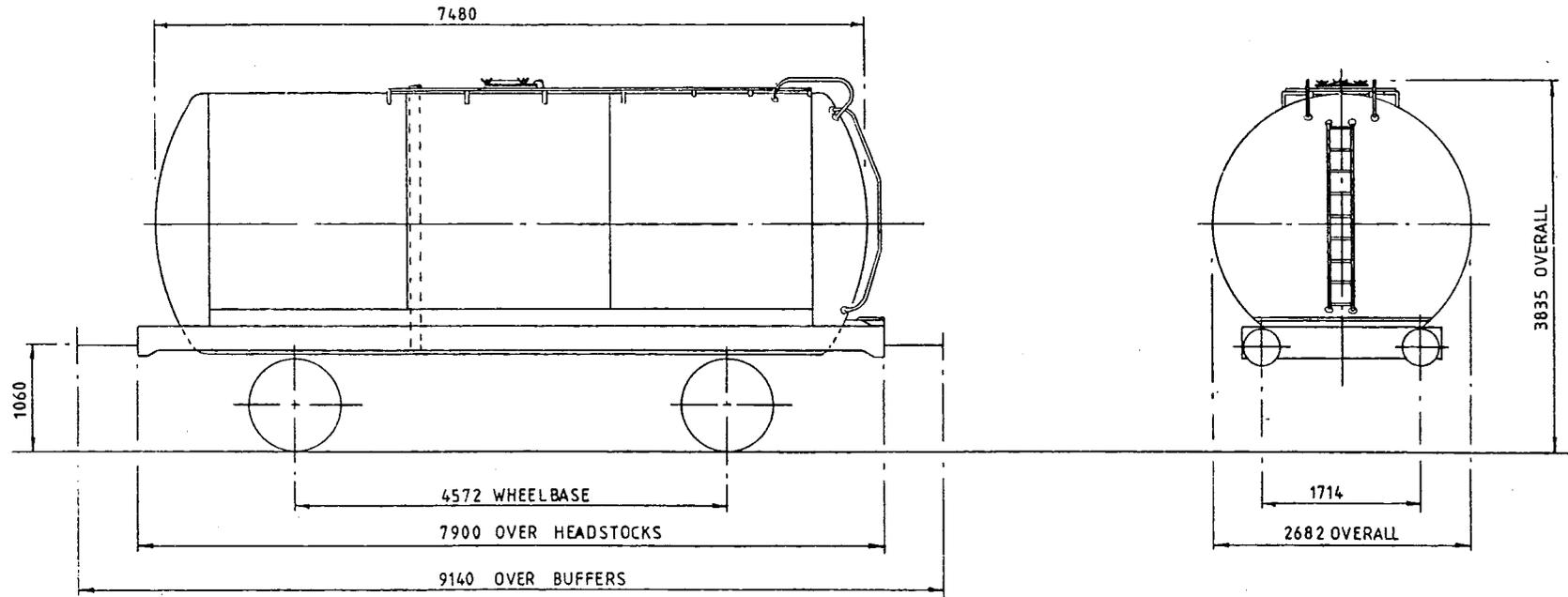

TARE-	13.700 Kg
CAPACITY, WEIGHT-	32.300 Kg
CAPACITY, VOLUME-	37.732 litres
MIN. CURVE-	31m
GEN. ARRGT. DRG. NO.-	

BRAKE-	AIR BLOCK & HAND LEVER
SUSPENSION-	GLOUCESTER PIVOT LINK
COUPLINGS-	INTERNATIONAL SCREW
BUFFERS-	HYDRAULIC 406 DIA HEADS
WHEELS-	952 DIA
JOURNALS-	140 DIA ROLLER BEARINGS

ISSUE 1

46 tonne GLW TANK WAGON - CLASS 'A'

LOT NUMBER	

TOPS INFORMATION						
AARKND	OPERATING	OPERATING SPEED		BRAKE FORCE DATA		EXCESS LENGTH
CARKND	PANEL No.	60 mile/h UP TO	46 tonne GLW	8t FORCE UP TO	31 tonne GLW	5
T T A A		mile/h ABOVE		19t FORCE ABOVE		
						RA (GLW) 9
						DESIGN SHEET W1043

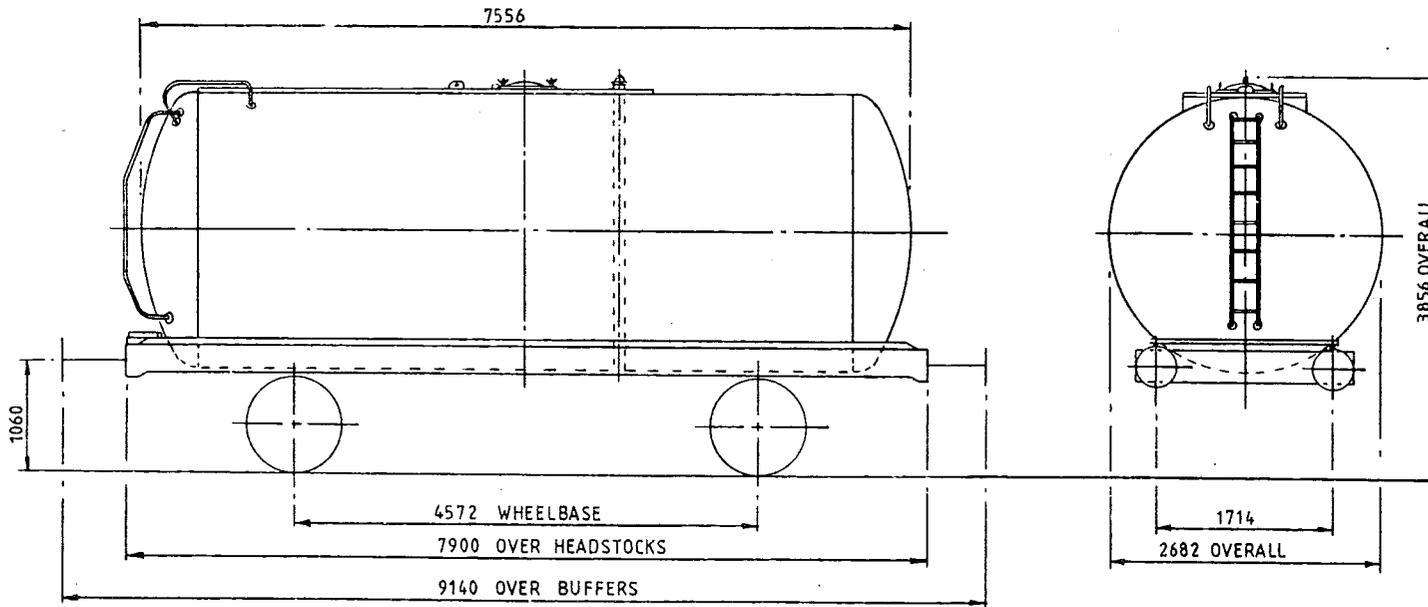

TARE-	12.800 Kg
CAPACITY, WEIGHT-	33.200 Kg
CAPACITY, VOLUME-	38.186 litres
MIN. CURVE-	31 m
GEN. ARRGT. DRG. NO.-	

BRAKE-	AIR BLOCK & HAND LEVER
SUSPENSION-	DOUBLE LINK & PARABOLIC SPRING
COUPLINGS-	INTERNATIONAL SCREW
BUFFERS-	HYDRAULIC 406 DIA HEADS
WHEELS-	952 DIA
JOURNALS-	140 DIA ROLLER BEARINGS

46 tonne GLW TANK WAGON - CLASS A

LOT NUMBER	

TOPS INFORMATION										
AARKND	OPERATING			OPERATING SPEED		BRAKE FORCE DATA		EXCESS LENGTH	RA (GLW)	DESIGN SHEET
CARKND	PANEL No.			60 mile/h UP TO	46 tonne GLW	6t FORCE UP TO	30.5 tonne GLW	5	9	W1127 W1311
T T A A				mile/h ABOVE		25t FORCE ABOVE				

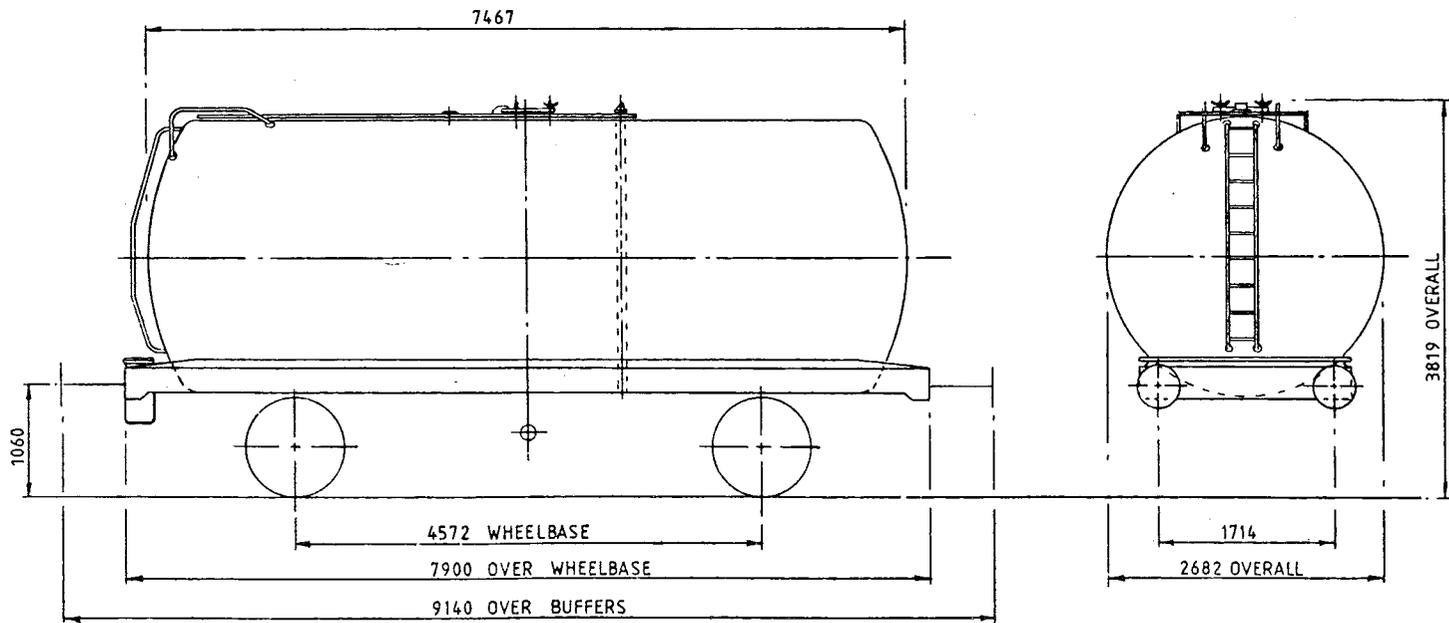

TARE-	13,700 Kg
CAPACITY, WEIGHT-	32,300 Kg
CAPACITY, VOLUME-	39,322 litres
MIN. CURVE-	31 m
GEN. ARRGT. DRG. NO.-	

BRAKE-	AIR BLOCK & HAND LEVER
SUSPENSION-	DOUBLE LINK & PARABOLIC SPRING
COUPLINGS-	INTERNATIONAL SCREW
BUFFERS-	HYDRAULIC 406 DIA HEADS
WHEELS-	952 DIA
JOURNALS-	140 DIA ROLLER BEARINGS

ISSUE 1

46 tonne GLW TANK WAGON - CLOSE COUPLED

LOT NUMBER	

TOPS INFORMATION									
AARKND	OPERATING		OPERATING SPEED		BRAKE FORCE DATA		EXCESS LENGTH	RA (GLW)	DESIGN SHEET
CARKND	PANEL No.		60 mile/h UP TO 46 tonne GLW		5 t FORCE UP TO 30.5 tonne GLW		4	9	W1309
T T A A									

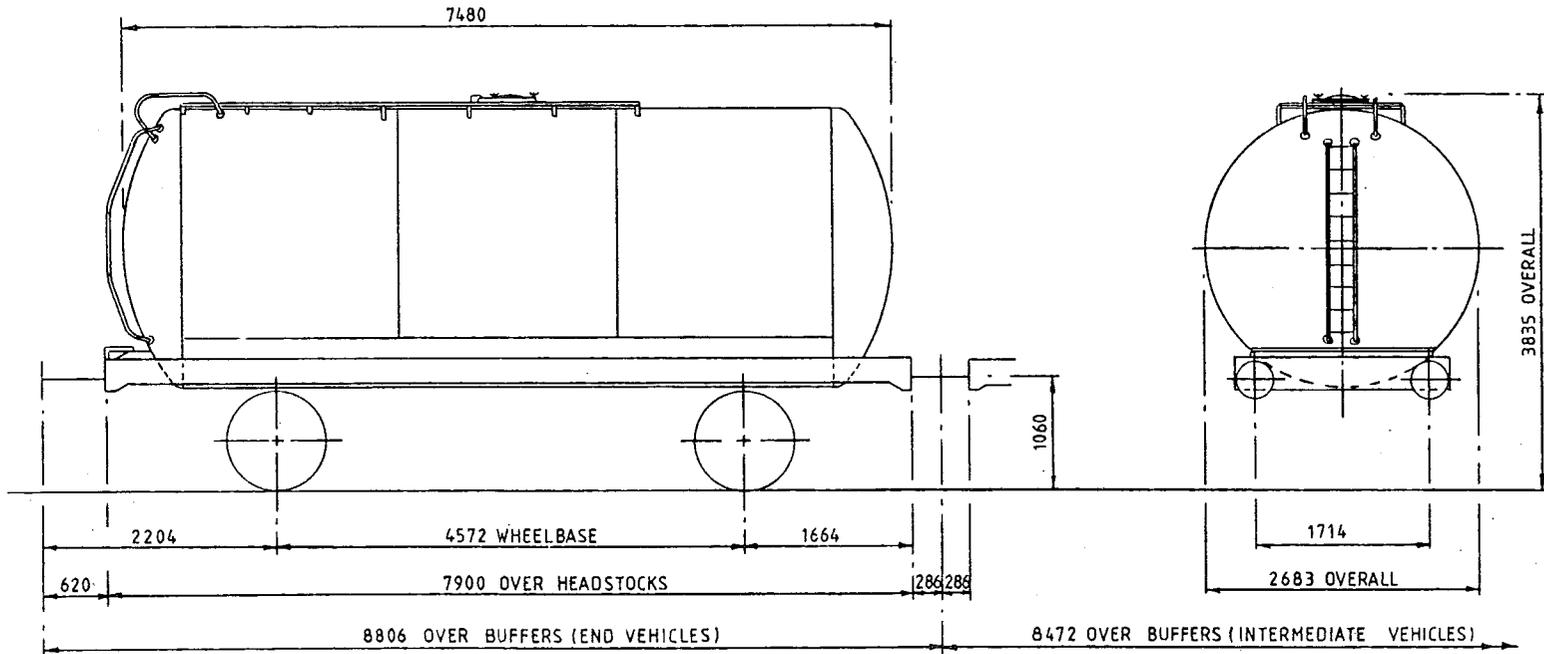

TARE-	12.500 Kg
CAPACITY, WEIGHT-	33.500 Kg
CAPACITY, VOLUME-	37.732 litres
MIN. CURVE-	31m
GEN. ARRGT. DRG. NO.-	

BRAKE-	AIR BLOCK & HAND LEVER
SUSPENSION-	DOUBLE LINK & PARABOLIC SPRING
COUPLINGS-	INTERNATIONAL SCREW & CLOSE COUPLED
BUFFERS-	HYDRAULIC 406 DIA HEADS
WHEELS-	952 DIA
JOURNALS-	140 DIA ROLLER BEARINGS

ISSUE 1

46 tonne GLW TANK WAGON-CLASS 'A' - CLOSE COUPLED

LOT NUMBER	

TOPS INFORMATION						
AARKND	OPERATING	OPERATING SPEED		BRAKE FORCE DATA		EXCESS LENGTH
CARKND	PANEL No.	60 mile/h UP TO	46 tonne GLW	10t FORCE UP TO	31 tonne GLW	RA (GLW)
T T A		mile/h ABOVE		22t FORCE ABOVE		4
						9
						W1418

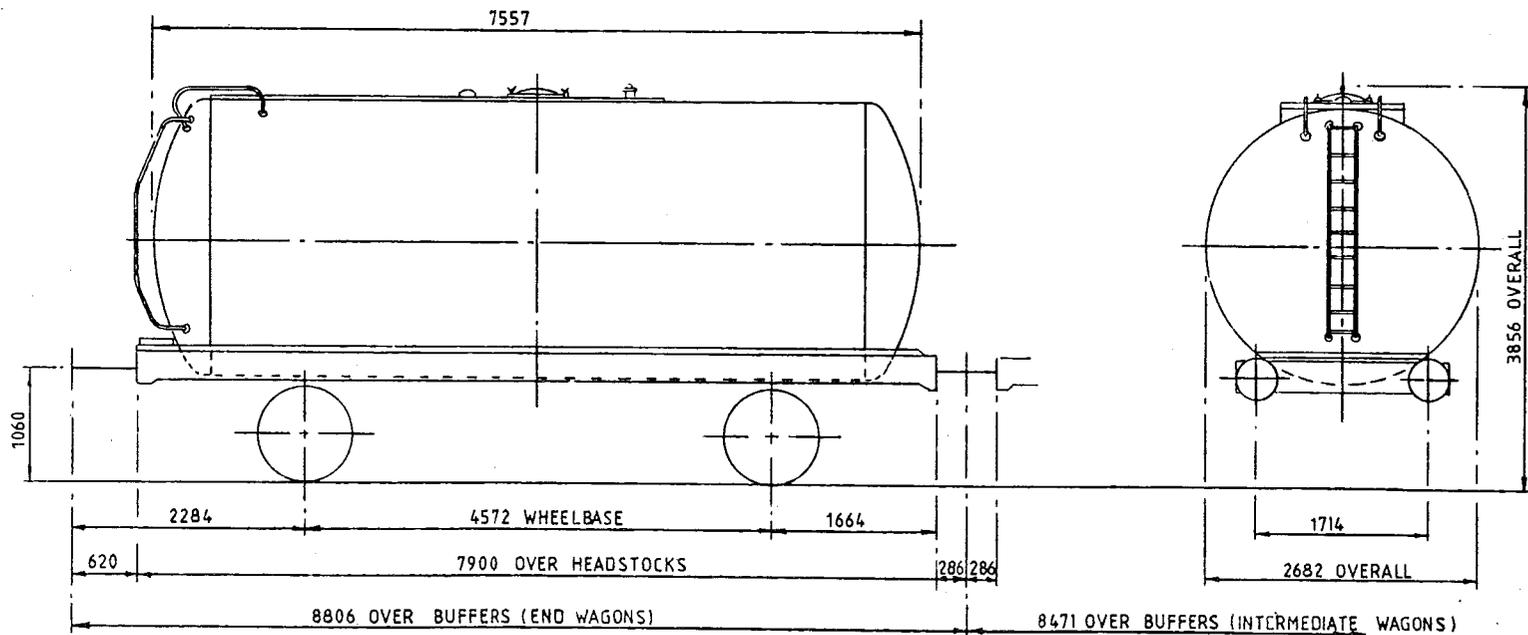

TARE-	12,700 Kg
CAPACITY, WEIGHT-	33,300 Kg
CAPACITY, VOLUME-	38,186 litres
MIN. CURVE-	31m
GEN. ARRGT. DRG. NO.-	

BRAKE-	AIR BLOCK & HAND LEVER
SUSPENSION-	DOUBLE LINK & PARABOLIC SPRING
COUPLINGS-	INTERNATIONAL SCREW & CLOSE COUPLED
BUFFERS-	HYDRAULIC 406 DIA HEADS
WHEELS-	952 DIA
JOURNALS-	140 DIA ROLLER BEARINGS

ISSUE 1

46 tonnes G.L.W. TANK WAGON CLASS B - CLOSE COUPLED.

TTO44A

EXCESS LENGTH	4	H	M	L	E
tonnes	46	46	14	14	
VB					
AB	22	22	14	14	
RA	8	8	1	1	
MAX. SPEED	60	60	45	45	

TOPS CODE										
CARKND	AARKND				OPERATING PANEL No.					
T	T	A	T	T	A	A	1	5	4	5

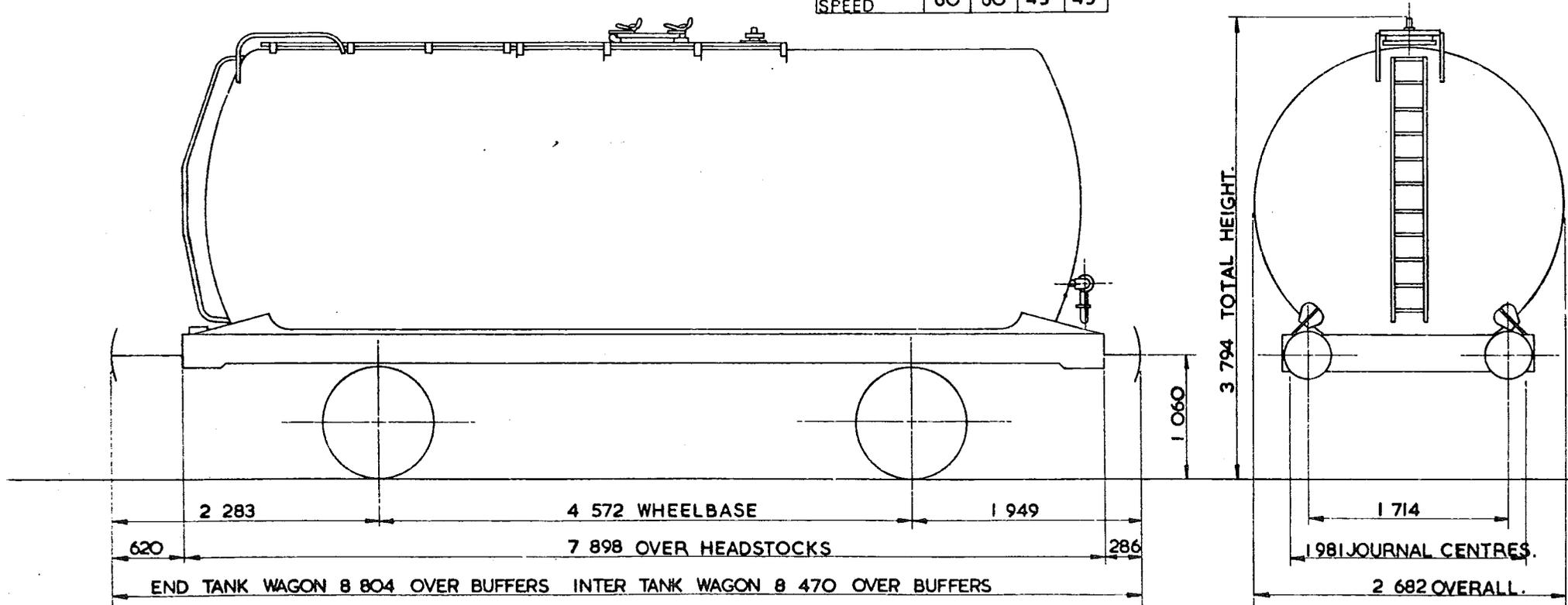

TARE - 13 550 kg.
CARRYING CAPACITY - 32 400 kg
CAPACITY - 39 905 litres
MAX. SPEED - 60 mile/h
WHEELS - 952 DIA
JOURNALS - 140 DIA ROLLER BEARINGS

BUFFERS - HYDRAULIC 406 DIA HEADS
COUPLINGS - INTERNATIONAL SCREW, CLOSE COUPLED
MIN. CURVE - 31 m
GEN. ARRGT. DRG No. -
BRAKE - AIR BLOCK & HAND LEVER.
SUSPENSION - DOUBLE LINK

BUILDER - POWELL DUFFRYN
OWNER - B.R.T. & E. LTD.
REGISTERED BY - C.M. & E.E. (B.R.B.) DERBY
YEAR BUILT - 1966/67
REGISTRATION Nos. - 57382 - 57476 (RANGE)
OWNERS Nos. - 10027 - 10126 (RANGE).

ISSUE 2
EX. B.R. DIAGRAM 6/221

46 tonnes G.L.W. TANK WAGON

TTO44C

EXCESS LENGTH 4	H	M	L	E
tonnes	46	46	17	17
VB	0	0	0	0
AB	22	22	10	10
RA	8	8	1	1
MAX SPEED	60	60	45	45

TOPS CODE		
CARKND	AARKND	OPERATING PANEL No.
T T B	T T B A	1 5 3 4

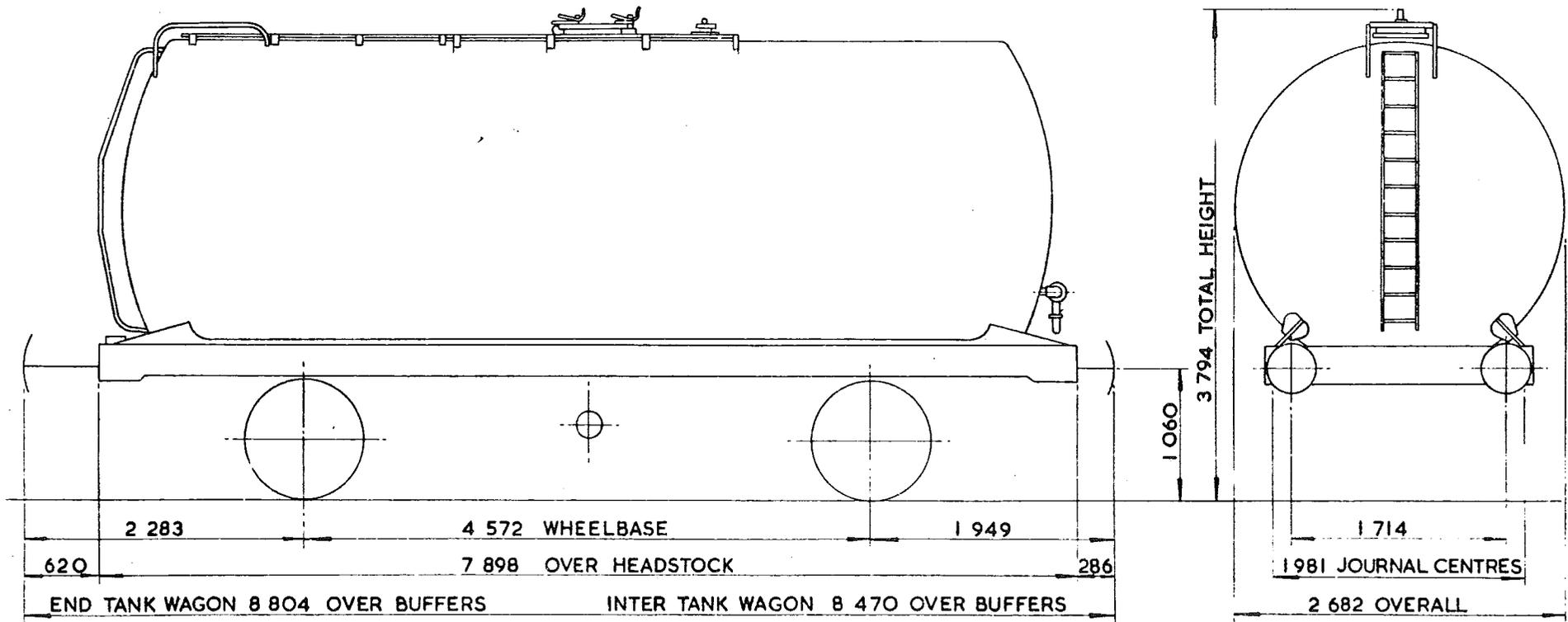

TARE - 16 950 kg
CARRYING CAPACITY - 29 000 kg
CAPACITY - 32 722 litres
MAX. SPEED - 60 miles/h
WHEELS - 952 DIA.
JOURNALS - 140 DIA. ROLLER BEARINGS

BUFFERS - HYDRAULIC 406 DIA. HEADS.
COUPLINGS - INTERNATIONAL SCREW, CLOSE COUPLED.
MIN CURVE - 31 m
GEN ARRGT DRG No. -
BRAKE - AIR BLOCK, VACUUM PIPED & HAND LEVER.
SUSPENSION - DOUBLE LINK

BUILDER - POWELL DUFFRYN
OWNER - SUKO
REGISTERED BY - C.M. & E.E. (B.R.B.) DERBY
YEAR BUILT - 1966
REGISTRATION Nos. - 61513 TO 61637
OWNERS Nos. -

ISSUE 2

EX P.O. DIAGRAM 6/733 (ALLOCATED)

46 tonnes G.L.W. TANK WAGON

TTO44D

EXCESS LENGTH	4	H	M	L	E
tonnes	46	46	17	17	
VB	0	0	0	0	
AB	22	22	10	10	
GA	8	8	1	1	
MAX SPEED	60	60	45	45	

TOPS CODE										
CARKND			AARKND			OPERATING PANEL No.				
T	T	B	T	T	B	A	1	5	3	4

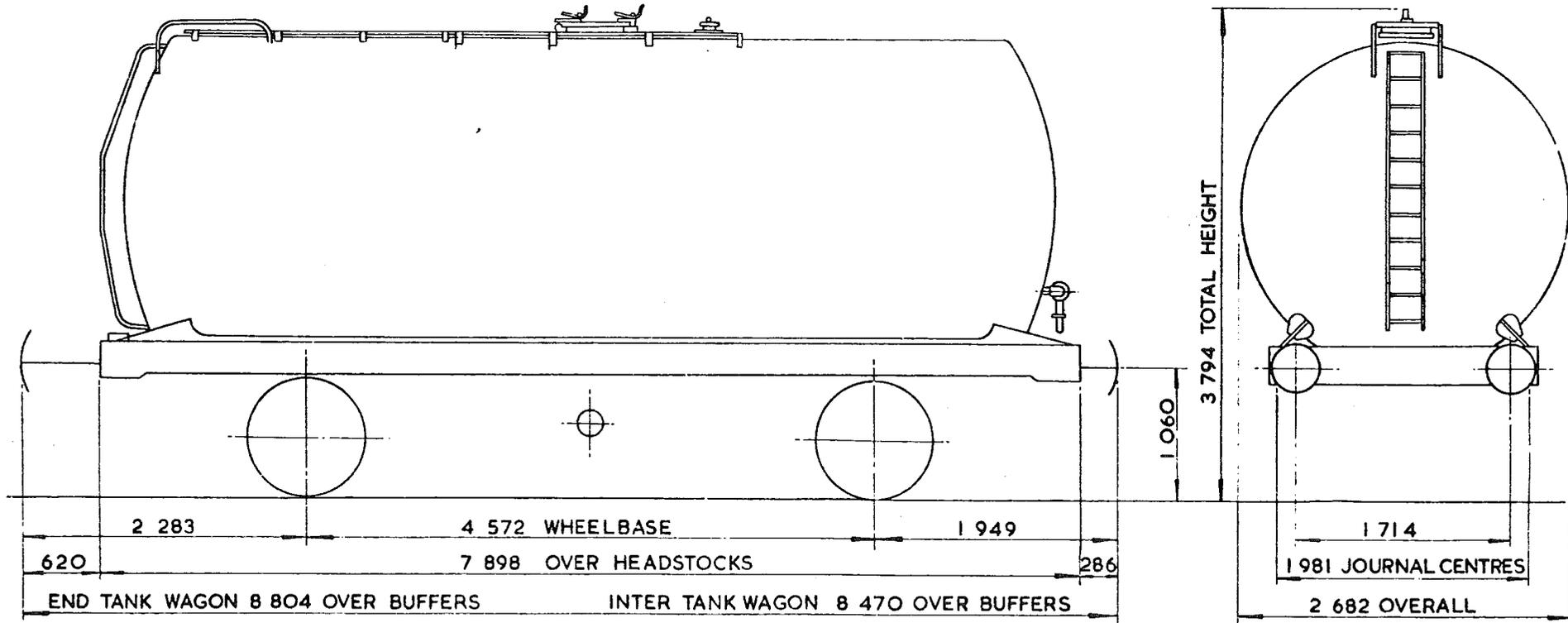

TARE - 16 500 kg
CARRYING CAPACITY - 29 500 kg.
CAPACITY - 33 013 litres.
MAX. SPEED - 60 mile/h
WHEELS - 952 DIA.
JOURNALS - 140 DIA. ROLLER BEARINGS

BUFFERS - HYDRAULIC 406 DIA. HEADS.
COUPLINGS - INTERNATIONAL SCREW, CLOSE COUPLED.
MIN. CURVE - 31 m
GEN. ARRGT. DRG. No. -
BRAKE - AIR BLOCK, VACUUM PIPED & HAND LEVER.
SUSPENSION - DOUBLE LINK

BUILDER - POWELL DUFFRYN
OWNER - SUKO.
REGISTERED BY - C.M. & E.E. (B.R.B.) DERBY
YEAR BUILT - 1967
REGISTRATION Nos. - 61638 TO 61907 (RANGE).
OWNERS Nos. -

ISSUE 2

EX. P.O. DIAGRAM 6/734 (ALLOCATED.)

46 tonnes GLW TANK WAGON

TTO44E

EXCESS LENGTH	4	H	M	L	E
tonnes	46	46	14	14	
VB					
AB	22	22	7	7	
RA	8	8	1	1	
MAX. SPEED	60	60	60	60	

TOPS CODE								
CARKND			AARKND			OPERATING PANEL No		
T	T	A	T	T	A	A	1	5
8	6							

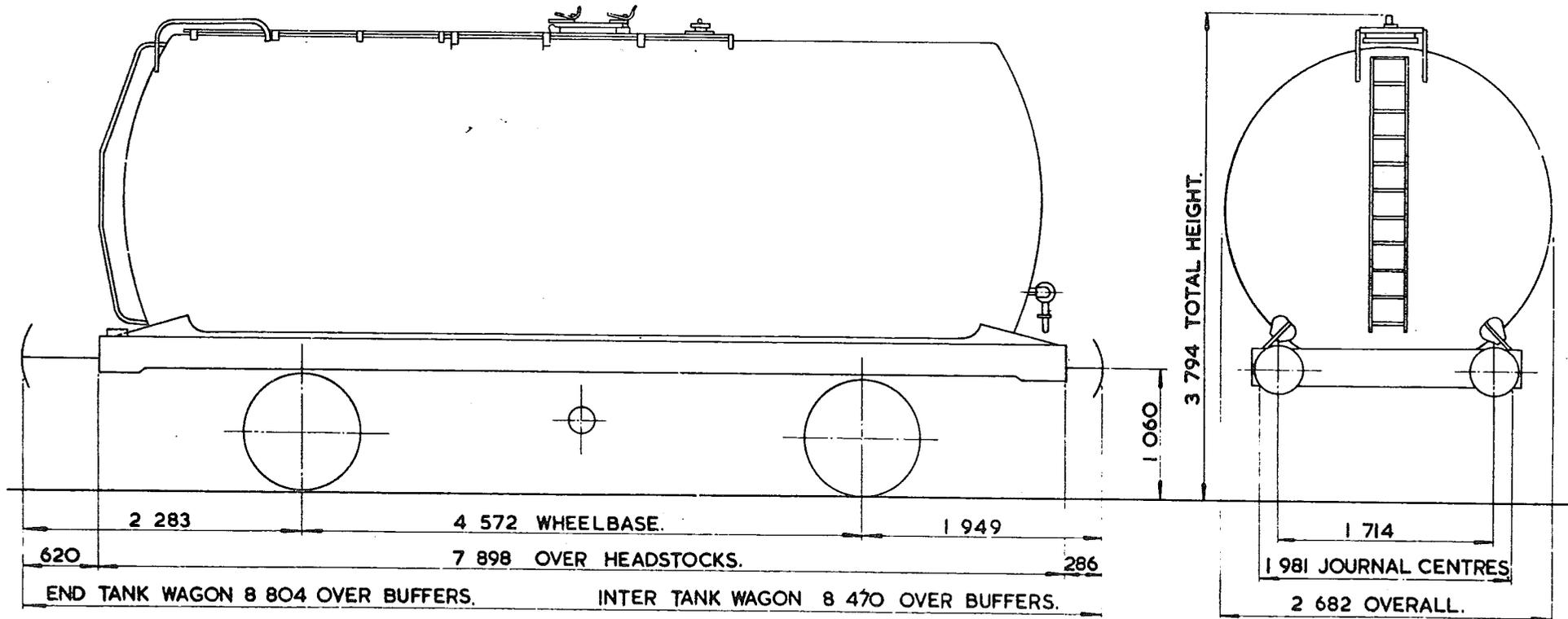

TARE -	16 500 kg.
CARRYING CAPACITY -	29 500 kg
CAPACITY -	33 013 litres.
MAX SPEED -	60 mile/h.
WHEELS -	952 DIA.
JOURNALS -	140 DIA. ROLLER BEARINGS.

BUFFERS -	HYDRAULIC 406 DIA. HEADS.
COUPLINGS -	INTERNATIONAL SCREW, CLOSE COUPLED.
MIN CURVE -	31m.
GEN. ARRGT. DRG. No. -	
BRAKE -	AIR BLOCK & HAND LEVER
SUSPENSION -	DOUBLE LINK.

BUILDER -	POWELL DUFFRYN.
OWNER -	BRT & E
REGISTERED BY -	C.M. & E. E. (B.R.B.) DERBY.
YEAR BUILT -	1967.
REGISTRATION Nos. -	57394 TO 57450 (RANGE).
OWNERS Nos. -	

46 tonnes G.L.W. TANK WAGON - CLASS A

TTO45A

EXCESS LENGTH	5	H	M	L	E
tonnes	46	46	14	14	
VB	20	20	8	8	
AB					
RA	8	8	1	1	
MAX. SPEED	60	60	45	45	

TOPS CODE										
CARKND			AARKND			OPERATING PANEL No				
T	T	F	T	T	F	A	1	5	0	2

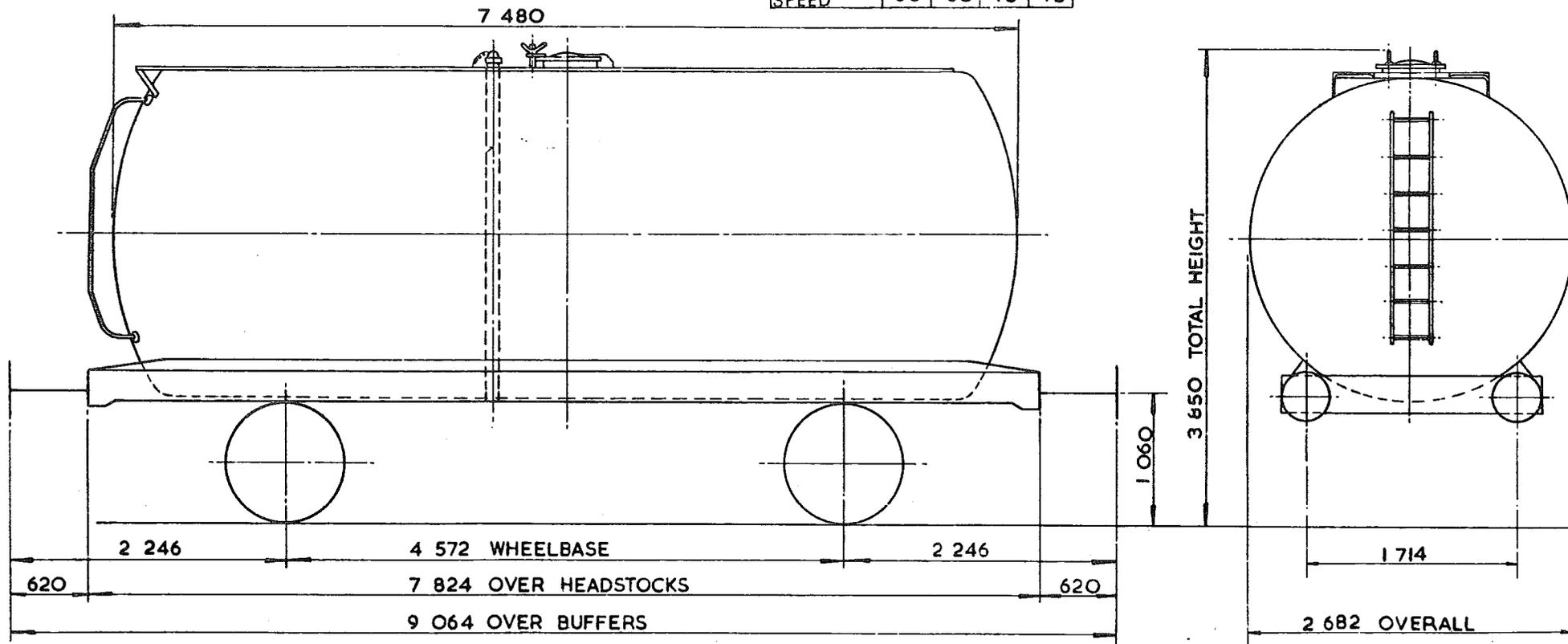

TARE - 13 700 kg
CARRYING CAPACITY - 32 300 kg
CAPACITY - 39 368 litres.
MAX. SPEED - 60 mile/h
WHEELS - 952 DIA.
JOURNALS - 140 DIA. ROLLER BEARINGS

BUFFERS - HYDRAULIC 406 DIA. HEADS.
COUPLINGS - INTERNATIONAL SCREW
MIN. CURVE - 31m
GEN. ARRGT. DRG. No. -
BRAKE - VACUUM BLOCK & HAND LEVER
SUSPENSION - DOUBLE LINK

BUILDER - PRESSED STEEL
OWNER - BRITISH RAILWAY TRAFFIC & ELECTRIC
REGISTERED BY - C.M. & E.E. (B.R.B.) DERBY
YEAR BUILT - 1965
REGISTRATION Nos. - 57192
OWNERS Nos. - 5758

ISSUE 2

46 tonnes G.L.W. TANK WAGON - CLASS B

TTO45B

EXCESS LENGTH	5	H	M	L	E
tonnes.	46	46	14	14	
VB	0	0	0	0	
AB	22	22	10	10	
RA	8	8	1	1	
MAX. SPEED	60	60	45	45	

TOPS CODE					
CARKND	AARKND		OPERATING PANEL No		
T T B	T T B	A	1	4	9 2

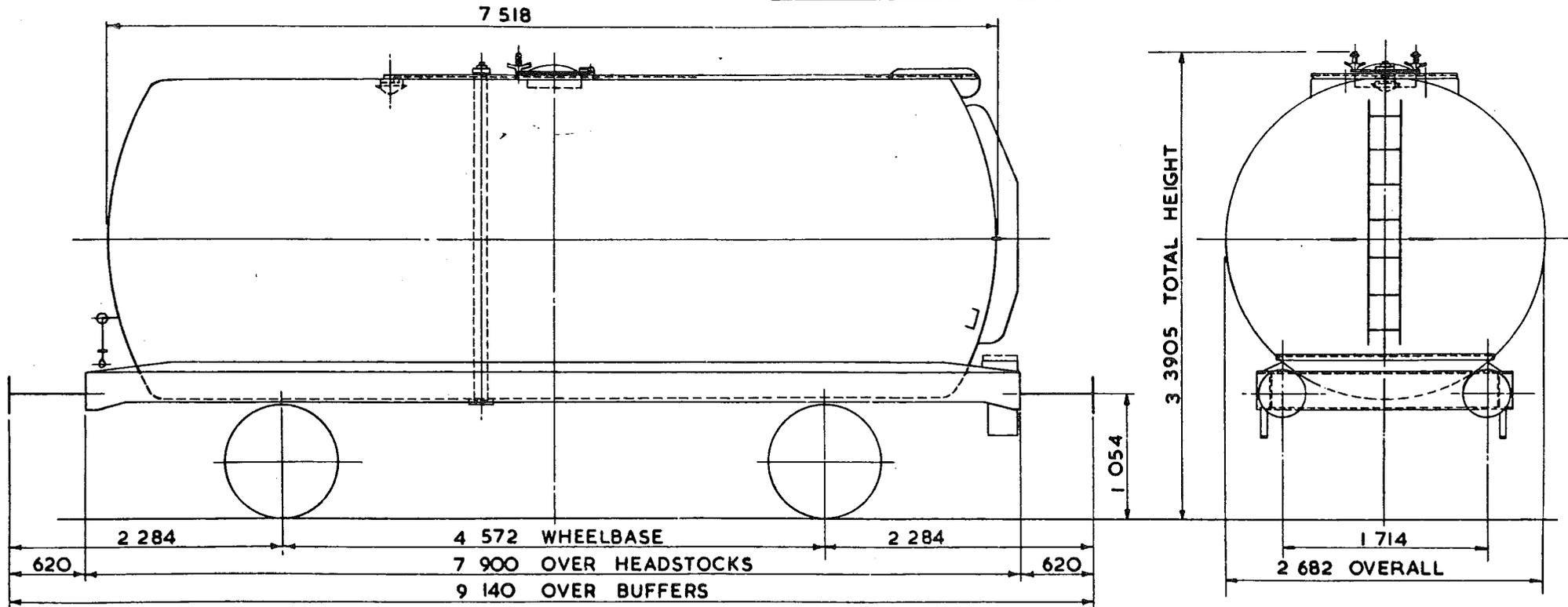

TARE - 13700kg.
CARRYING CAPACITY - 32300kg.
CAPACITY - 39550 litres.
MAX. SPEED - 60 mile/h.
WHEELS - 952 DIA.
JOURNALS - 140 DIA. ROLLER BEARINGS

BUFFERS - HYDRAULIC 406 DIA. HEADS.
COUPLINGS - INTERNATIONAL SCREW
MIN. CURVE - 31m.
GEN ARRGT. DRG. No. -
BRAKE - AIR BLOCK, VACUUM PIPED & HAND LEVER.
SUSPENSION - DOUBLE LINK

BUILDER - ROOTES PRESSINGS
OWNER - B.R.T. & E. LTD.
REGISTERED BY - C.M. & E.E. (B.R.B) DERBY.
YEAR BUILT - 1966
REGISTRATION Nos. - 57350 TO 57376
OWNERS Nos. - 10000 TO 10026

ISSUE 2
EX. P.O. DIAGRAM 6/170

46 tonnes G.L.W. TANK WAGON

TTO45C

DESIGN INFORMATION SHEET W1134

EXCESS LENGTH	H	M	L	E
TONS	46	46	14	14
VB	18	18	7	7
AB				
RA	8	8	1	1
MAX. SPEED	60	60	60	60

TOPS CODE										
CARKND			AARKND			OPERATING PANEL No.				
T	T	F	T	T	F	A	I	S	S	3

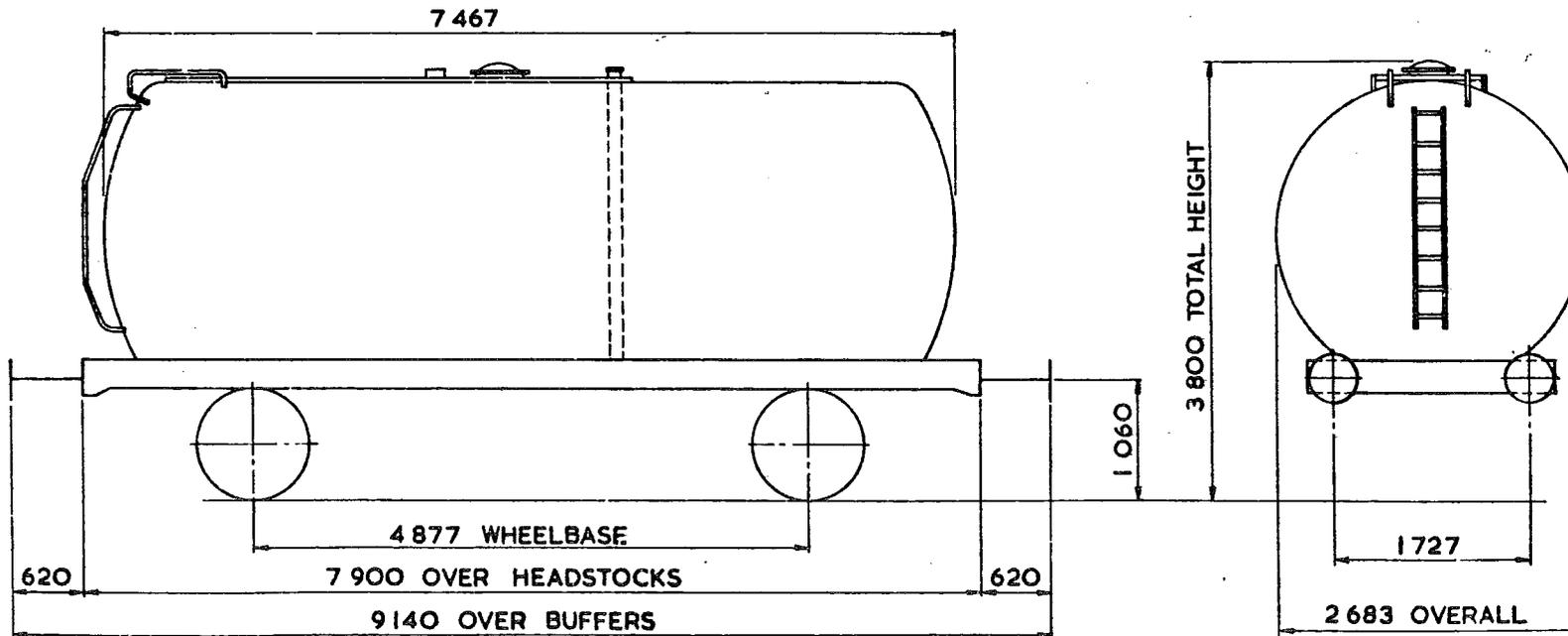

TARE - 14 200kg
CARRYING CAPACITY - 31 800kg
CAPACITY - 37 968 litres
MAX. SPEED - 60 mile / h
WHEELS - 952 DIA.
JOURNALS - 140 DIA. ROLLER BEARINGS

BUFFERS - HYDRAULIC 406 DIA. HEADS
COUPLINGS - INTERNATIONAL SCREW
MIN. CURVE - 31m
GEN. ARRGT. DRG. No. -
BRAKE - VACUUM BLOCK & HAND LEVER
SUSPENSION - DOUBLE LINK

ISSUE 3.
EX. P.O. DIAGRAM 6/136

46 tonnes G.L.W. TANK WAGON - BITUMEN.

TTO45D

EXCESS LENGTH	5	H	M	L	E
tonnes	46	46	16	16	
VB	0	0	0	0	
AB	22	22	12	12	
RA	8	8	1	1	
MAX. SPEED	60	60	45	45	

TOPS CODE									
CARKND			AARKND			OPERATING PANEL No			
T	T	B	T	B	A	I	4	9	3

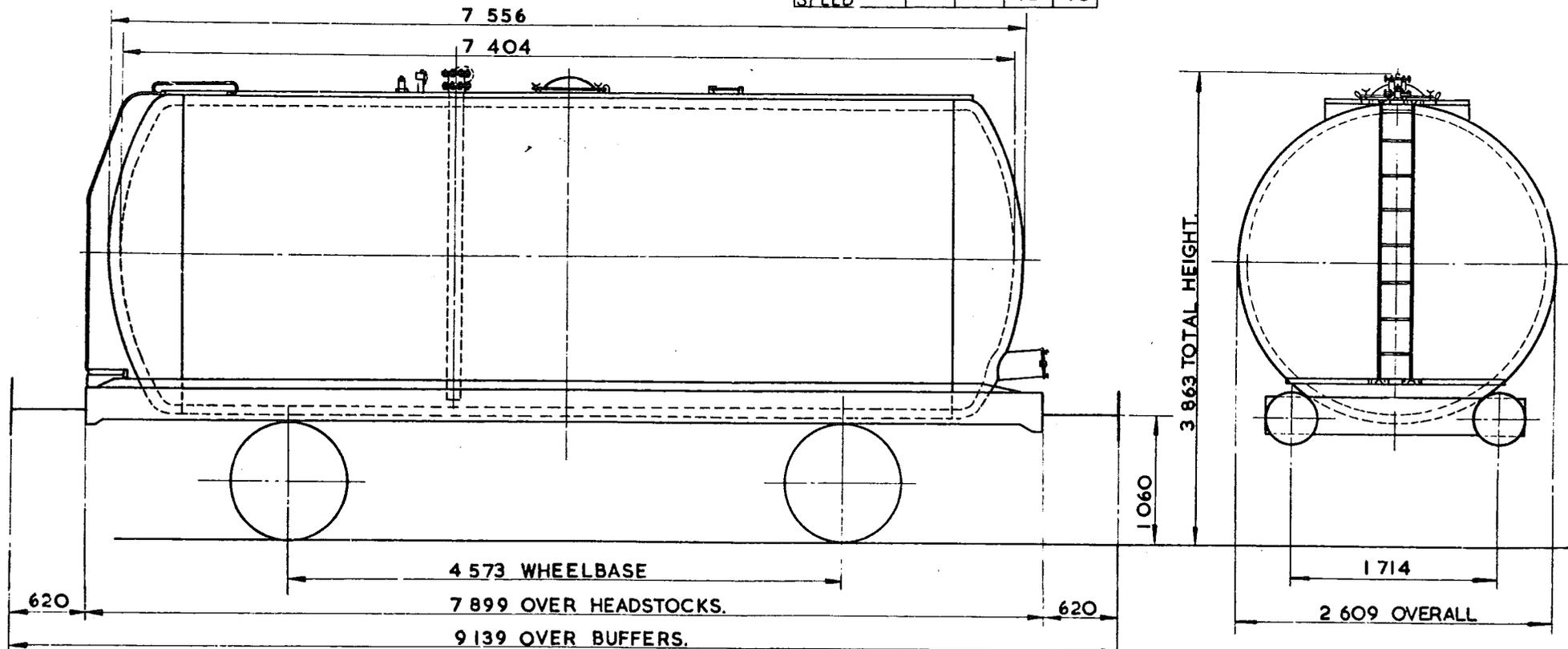

TARE	16000kg
CARRYING CAPACITY	30000kg
CAPACITY	29094 litres
MAX SPEED	60 mile/h
WHEELS	952 DIA.
JOURNALS	140 DIA. ROLLER BEARINGS.

BUFFERS	HYDRAULIC 406 DIA. HEADS
COUPLINGS	INTERNATIONAL SCREW.
MIN. CURVE	31m
GEN. ARRGT. DRG. No	
BRAKE	AIR BLOCK VACUUM PIPE & HAND LEVER
SUSPENSION	DOUBLE LINK.

BUILDER	R.Y. PICKERING.
OWNER	B.R.T.&E. LTD.
REGISTERED BY	C.M.&E.E. (B.R.B) DERBY
YEAR BUILT	1966.
REGISTRATION Nos.	57670. TO 57696. (RANGE)
OWNERS Nos.	10320. TO 10346. (RANGE)

4.6 tonne GLW TANK WAGON-CLASS B

TT045G

EXCESS LENGTH	4	H	M	L	E
tonnes	4.6	4.6	13	13	
VB	0	0	0	0	
AB	22	22	10	10	
RA	8	8	1	1	
MAX SPEED	60	60	60	60	

TOPS CODE										
CARKND		AARKND			OPERATION					
T	T	B	T	T	B	A	1	3	7	0

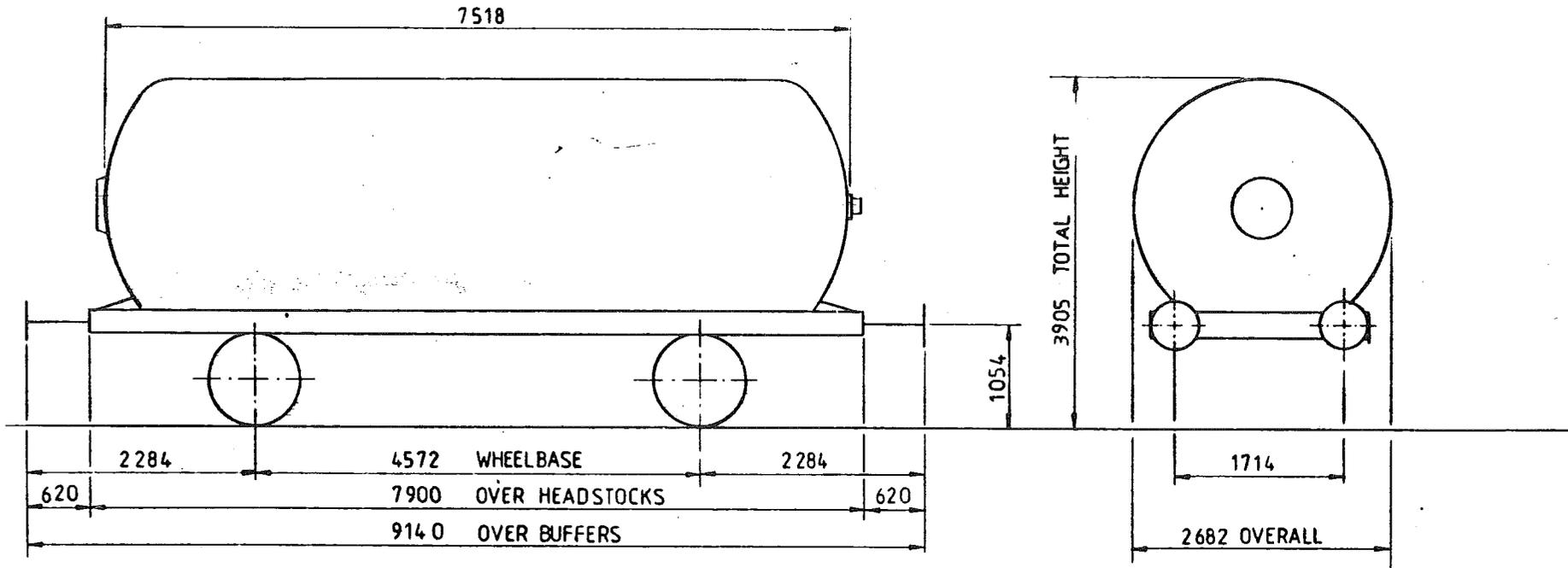

TARE	13000	kg
CARRYING CAPACITY	33000	kg
CAPACITY	39550	Litres
MAX SPEED	60	mile/h
WHEELS	φ 952	
JOURNALS	φ 140	ROLLER BEARINGS

BUFFERS	HYDRAULIC	φ 406	HEADS
COUPLINGS	INTERNATIONAL SCREW		
MIN CURVE	31m		
GEN ARRGT DRG No			
BRAKE	AIR BLOCK, VAC PIPED,	HAND LEVER	
SUSPENSION	FAT	26	

ISSUE 1

EX PO. DIAGRAM 6/170

46 tonne GLW TANK WAGON-CLASS 'A'

LOT NUMBER	

TOPS INFORMATION						
AARKND	OPERATING	OPERATING SPEED		BRAKE FORCE DATA		EXCESS LENGTH
CARKND	PANEL No.	60 mile/h UP TO	46 tonne GLW	5t FORCE UP TO	30.5tonneGLW	RA (GLW)
T T A A				24 t FORCE ABOVE		5
						9
						DESIGN SHEET W1126 W1310

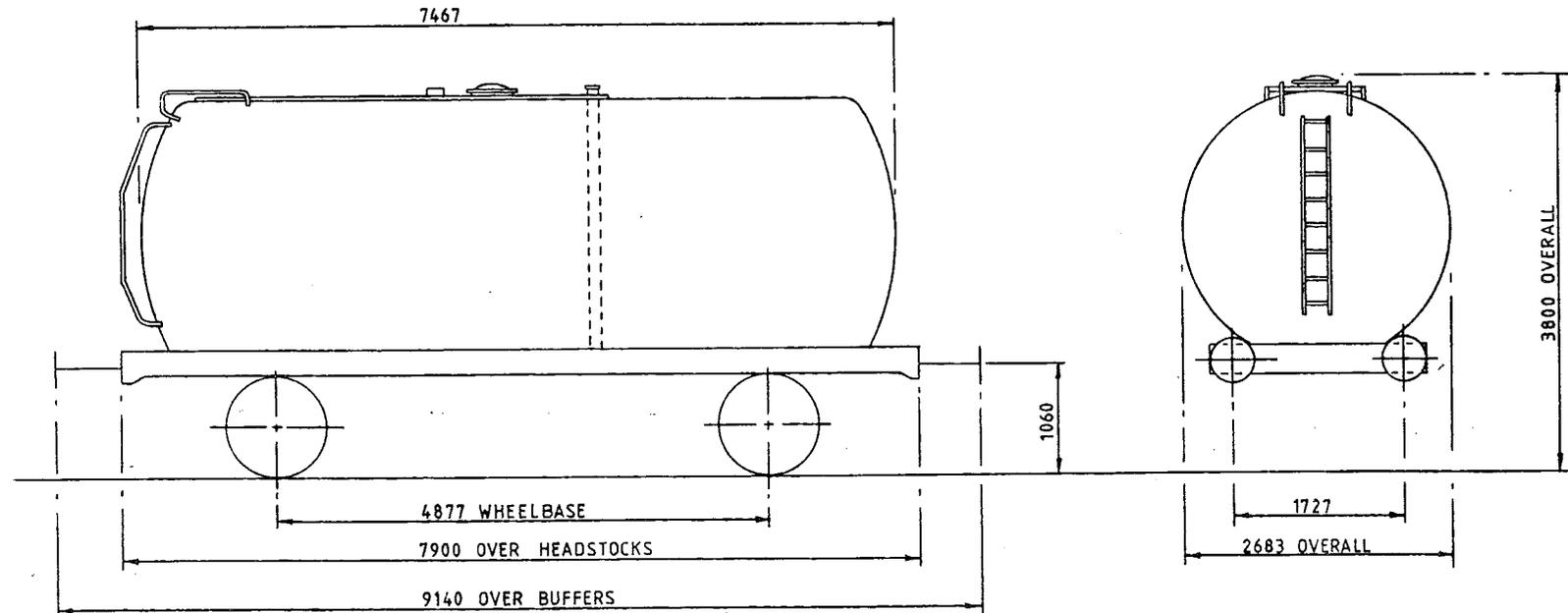

TARE-	14.300 Kg
CAPACITY, WEIGHT-	31.700 Kg
CAPACITY, VOLUME-	37.968 litres
MIN. CURVE-	31m
GEN. ARRGT. DRG. NO.-	

BRAKE-	AIR BLOCK & HAND LEVER
SUSPENSION-	DOUBLE LINK & PARABOLIC SPRING
COUPLINGS-	INTERNATIONAL SCREW
BUFFERS-	HYDRAULIC 406 DIA HEADS
WHEELS-	952 DIA
JOURNALS-	140 DIA ROLLER BEARINGS

ISSUE 1

46 tonne GLW TANK WAGON - CLASS B

LOT NUMBER	

TOPS INFORMATION								
AARKND	OPERATING	OPERATING SPEED		BRAKE FORCE DATA		EXCESS	RA	DESIGN
CARKND	PANEL No.	60 mile/h UP TO		12t FORCE UP TO		LENGTH	(GLW)	SHEET
T	T	B	A			5	8	W1170
				46 tonne GLW		31 tonne GLW		
				mile/h ABOVE		22t FORCE ABOVE		

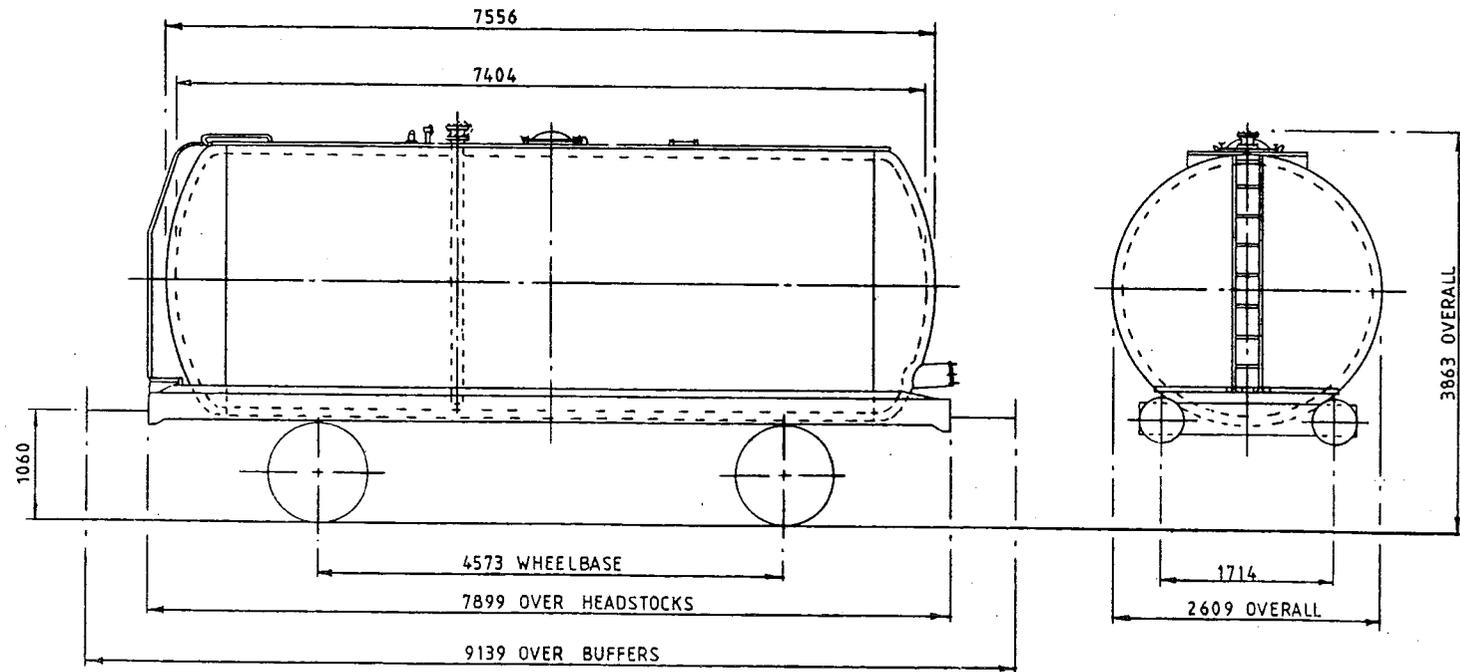

TARE-	16.000 Kg
CAPACITY, WEIGHT-	30.000 Kg
CAPACITY, VOLUME-	29.094 litres
MIN. CURVE-	31m
GEN. ARRGT. DRG. NO.-	

BRAKE-	AIR BLOCK, VAC PIPE, HAND LEVER
SUSPENSION-	DOUBLE LINK & PARABOLIC SPRING
COUPLINGS-	INTERNATIONAL SCREW
BUFFERS-	HYDRAULIC 406 DIA HEADS
WHEELS-	952 DIA
JOURNALS-	140 DIA ROLLER BEARINGS

ISSUE 1

46 tonnes G.L.W. TANK WAGON

TTO48A

EXCESS LENGTH	5	H	M	L	E
tonnes	46	46	14	14	
VB	18	18	7	7	
AB					
RA	8	8	1	1	
MAX SPEED	60	60	60	60	

TOPS CODE		
CARKND	AARKND	OPERATING
T T F T T F A	I 4 8 7	

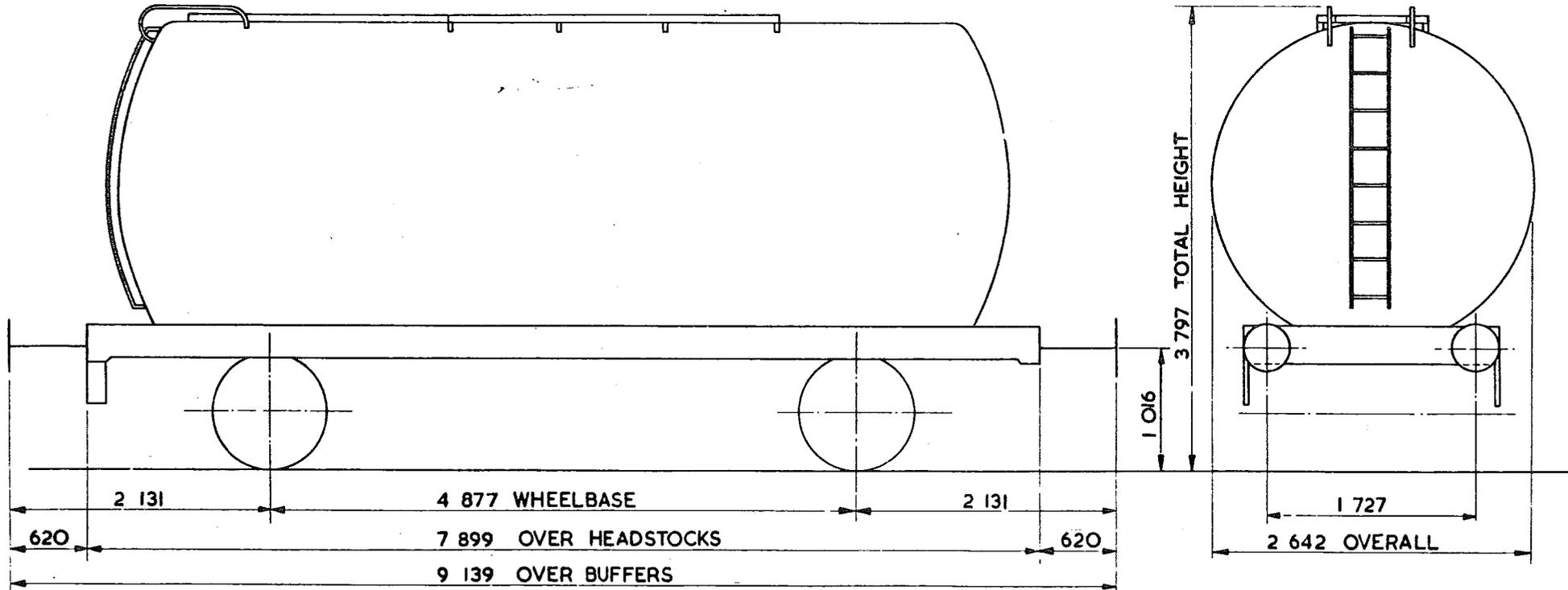

TARE - 14 050 kg
CARRYING CAPACITY - 31 900 kg
CAPACITY - 39 550 litres
MAX. SPEED - 60 mile/h
WHEELS - 952 DIA.
JOURNALS - 140 DIA. ROLLER BEARINGS

BUFFERS - HYDRAULIC 406 DIA. HEADS
COUPLINGS INTERNATIONAL SCREW
MIN. CURVE - 31m
GEN. ARRGT. DRG No -
BRAKE - VACUUM BLOCK & HAND LEVER
SUSPENSION - DOUBLE LINK

BUILDER - CHARLES ROBERTS
OWNER - TIGER RAILCAR LEASING.
REGISTERED BY - C.M.&E.E. (B.R.B.) DERBY
YEAR BUILT - 1966
REGISTRATION Nos. - 51824 - 51834
OWNERS Nos. - A824 - A834

ISSUE 2

EX. B.R. DIAGRAM 6/770 (ALLOCATED)

46 tonnes G.L.W. TANK WAGON

TTO49A

EXCESS LENGTH	H	M	L	E
4				
tonnes	46	46	13	13
VB	0	0	0	0
AB	23	23	8	8
RA	8	8	1	1
MAX. SPEED	60	60	45	45

TOPS CODE				
CARKND	AARKND	OPERATING PANEL No		
T	T	B	T	B
A	I	5	I	5

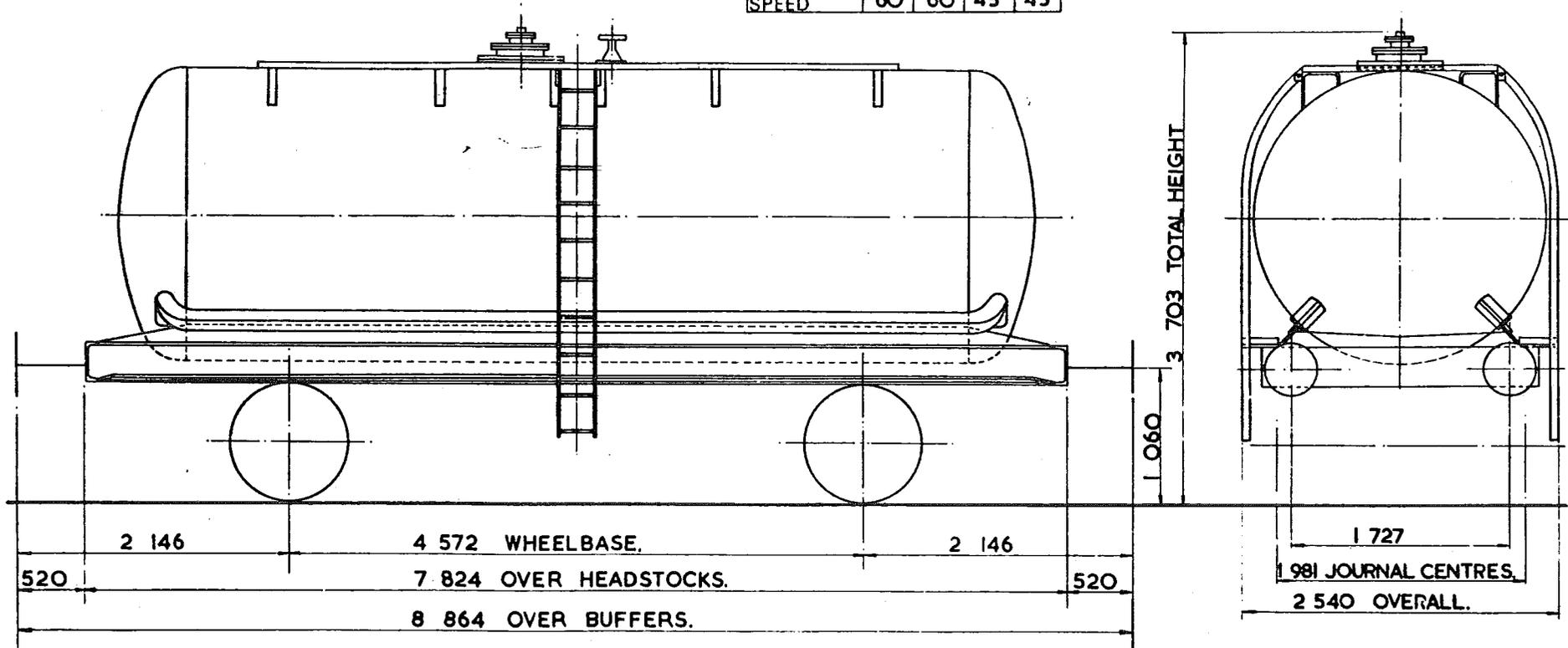

TARE - 13 ¹⁰⁰ kg.
CARRYING CAPACITY - 32,900 kg
CUBIC CAPACITY - 28,503 litres.
MAX. SPEED - 60 mile/h.
WHEELS - 952 DIA.
JOURNALS - 140 DIA. ROLLER BEARINGS.

BUFFERS - HYDRAULIC 406 DIA. HEADS
COUPLINGS - INSTANTER.
MIN. CURVE - 31m.
GEN. ARRGT. DRG. No. -
BRAKE - AIR BLOCK, VACUUM PIPED & HAND LEVER.
SUSPENSION - DOUBLE LINK.

BUILDER - STANDARD RAILWAY WAGON CO.
OWNER - PROCOR (U.K.) LTD.
REGISTERED BY - C.M. & E.E. (B.R.B.) DERBY.
YEAR BUILT - 1966.
REGISTRATION Nos. - 58202, 58204 TO 58211.
OWNERS Nos. - 202, 204 TO 211.

ISSUE 2

EX. P.O. DIAGRAM 6,691 (ALLOCATED.)

46 tonnes G.L.W. TANK WAGON-SODIUM HYPERCHLORITE

TTO49B

EXCESS LENGTH	4	H	M	L	E
tonnes	46	46	13	13	
VB	0	0	0	0	
AB	23	23	8	8	
RA	8	8	1	1	
MAX. SPEED	60	60	45	45	

TOPS CODE					
CARKND	AARKND	OPERATING PANEL No			
T	T	B	T	B	A
I	S	I	S	I	S

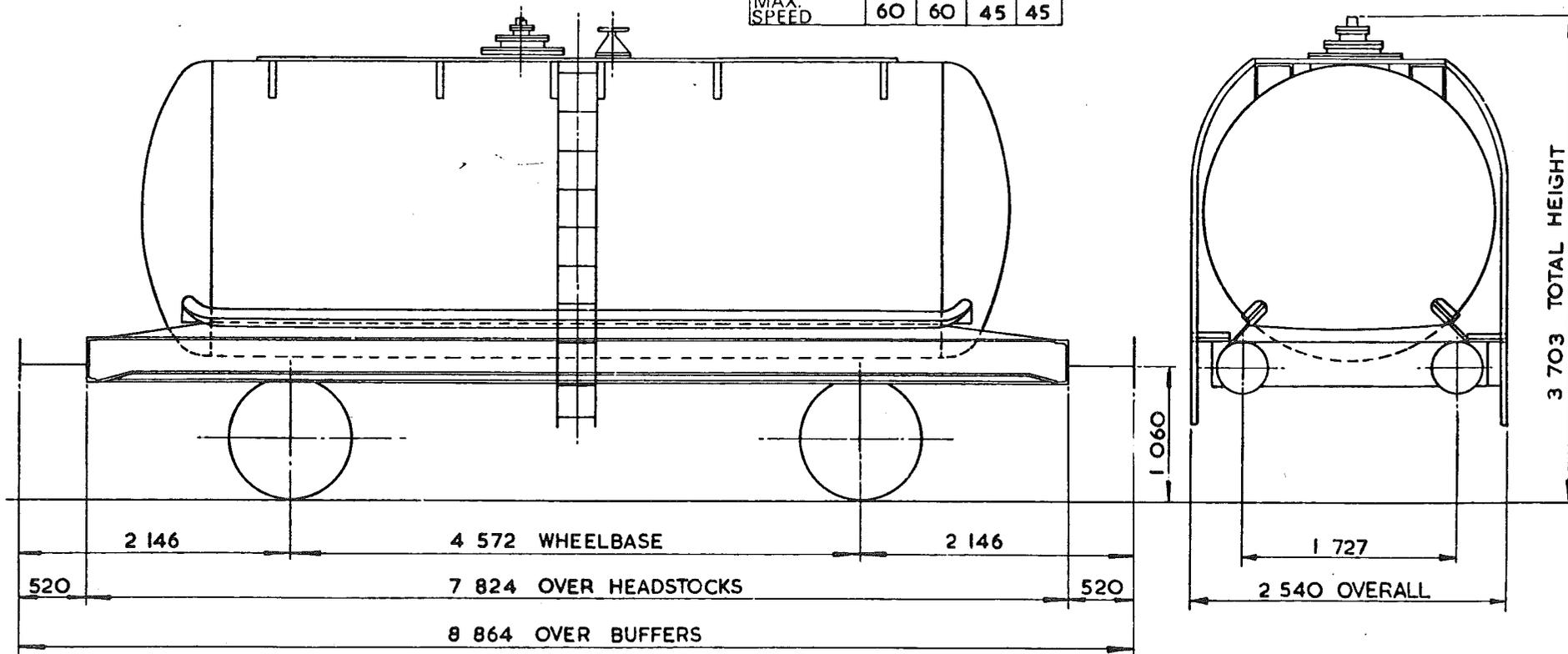

TARE - 12 950 kg
CARRYING CAPACITY - 33 000 kg
CAPACITY - 26 730 litres
MAX. SPEED - 60 mile/h
WHEELS - 952 DIA.
JOURNALS - 140 DIA. ROLLER BEARINGS

BUFFERS - HYDRAULIC 406 DIA. HEADS
COUPLINGS - INSTANTER
MIN. CURVE - 31 m
GEN. ARRGT. DRG. No. -
BRAKE - AIR BLOCK, VACUUM PIPED & HAND LEVER
SUSPENSION - DOUBLE LINK

BUILDER - STANDARD RAILWAY WAGON Co. LTD.
OWNER - PROCOR (U.K.) LTD
REGISTERED BY - CM. & E.E. (BRB.) DERBY
YEAR BUILT - 1966
REGISTRATION Nos. - 58213 TO 58216, 58218 TO 58220
OWNERS Nos. - 213 TO 216, 218 TO 220

ISSUE 2

EX. PO. DIAGRAM 6/692 (ALLOCATED)

46 tonnes G.L.W. TANK WAGON

TTO49C

EXCESS LENGTH	4	H	M	L	E
tonnes	46	46	13	13	
VB	0	0	0	0	
AB	23	23	8	8	
RA	8	8	1	1	
MAX SPEED	60	60	60	60	

TOPS CODE										
CARKND			AARKND			OPERATING PANEL No				
T	T	B	T	T	B	A	1	5	9	7

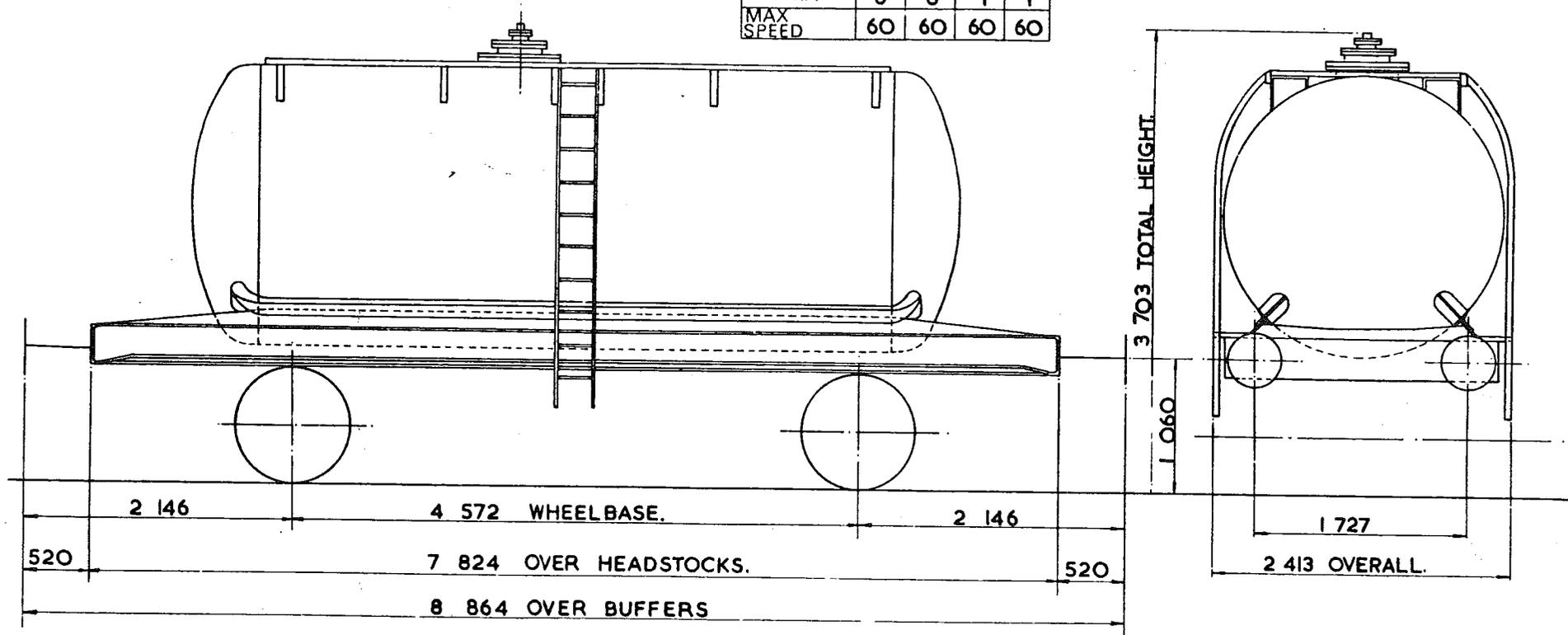

TARE - 12 ⁹⁰⁰ kg
CARRYING CAPACITY - 33 ¹⁰⁰ kg
CUBIC CAPACITY - 23 ₇₃₀ litres.
MAX. SPEED - 60 mile/h.
WHEELS - 952 DIA.
JOURNALS - 140 DIA. ROLLER BEARINGS.

BUFFERS - HYDRAULIC 406 DIA HEADS.
COUPLINGS - INSTANTER.
MIN. CURVE - 31m.
GEN. ARRGT. DRG. No. -
BRAKE - AIR BLOCK, VACUUM PIPED & HAND LEVER.
SUSPENSION - DOUBLE LINK.

BUILDER - STANDARD RAILWAY WAGON CO.
OWNER - PROCOR (U.K.) LTD.
REGISTERED BY - C.M. & E.E. (B.R.B.) DERBY.
YEAR BUILT - 1967.
REGISTRATION Nos. - 58300 TO 58307.
OWNERS Nos. - 300 TO 307.

ISSUE 2

EX. P.O. DIAGRAM 6/693 (ALLOCATED)

46 tonnes G.L.W. TANK WAGON - TRICHLORETHYLENE

TTO49D

EXCESS LENGTH	5	H	M	L	E
tonnes	46	46	13	13	
	Vb	0	0	0	0
	AB	27	27	10	10
	RA	8	8	1	1
MAX. SPEED	60	60	60	60	

TOPS CODE									
CARKND			AARKND			OPERATING PANEL No			
T	T	B	T	B	A	1	0	4	0

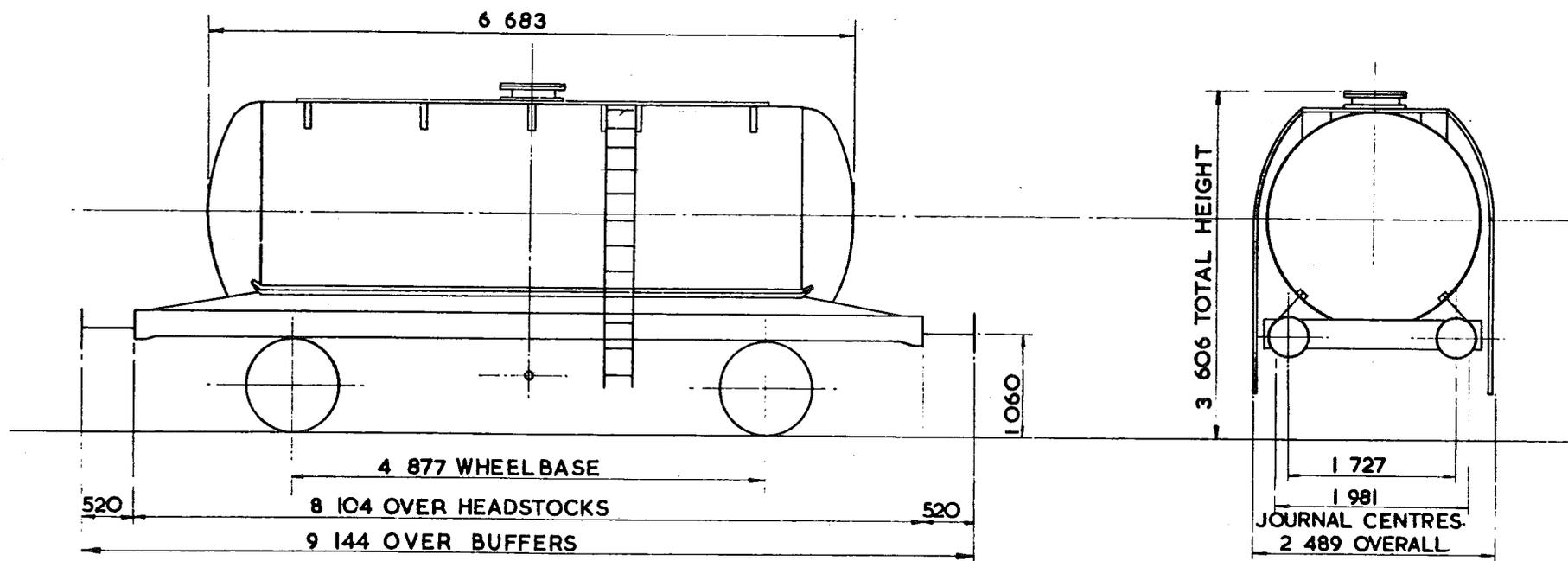

TARE - 12 700 kg
CARRYING CAPACITY - 33 300 kg
CAPACITY - 24 276 litres.
MAX. SPEED - 60 mile/h.
WHEELS - 952 DIA
JOURNALS - 140 DIA. ROLLER BEARINGS

BUFFERS - HYDRAULIC 406 DIA. HEADS
COUPLINGS - INSTANTER
MIN. CURVE - 31m
GEN. ARRGT. DRG. No. -
BRAKE - AIR BLOCK, VACUUM PIPED & HAND LEVER.
SUSPENSION - DOUBLE LINK

BUILDER - STANDARD RAILWAY WAGON Co.
OWNER - PROCOR (UK.) LTD.
REGISTERED BY - C. M. & E. E. (B. R. B.) DERBY.
YEAR BUILT - 1970
REGISTRATION Nos. - 5B308 TO 5B313
OWNERS Nos - 308 TO 313

46 tonnes G.L.W. TANK WAGON – CAUSTIC LIQUOR

TTO49E

EXCESS LENGTH	4	H	M	L	E
tonnes	46	46	14	14	
VB	0	0	0	0	
AB	22	22	8	8	
RA	8	8	1	1	
MAX SPEED	60	60	45	45	

TOPS CODE										
CARKND			AARKND			OPERATING PANEL No				
T	T	B	T	T	E	A	1	5	2	4

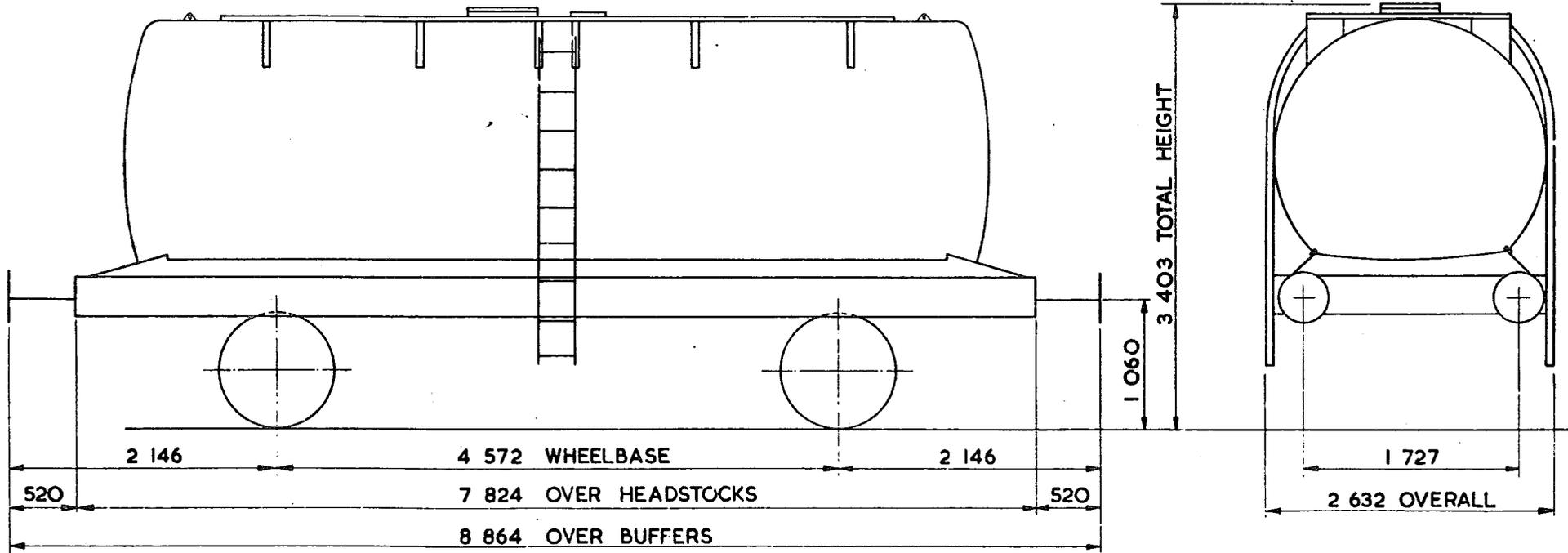

TARE – 13 200 kg
CARRYING CAPACITY – 32 800 kg
CAPACITY – 22 325 litres
MAX. SPEED – 60 mile/h
WHEELS – 952 DIA.
JOURNALS – 140 DIA. ROLLER BEARINGS

BUFFERS – HYDRAULIC 406 DIA. HEADS
COUPLINGS – INSTANTER
MIN CURVE – 31 m
GEN. ARRGT. DRG. No. –
BRAKE – AIR BLOCK, VACUUM PIPED & HAND LEVER
SUSPENSION – DOUBLE LINK

BUILDER – STANDARD RAILWAY WAGON Co.
OWNER – PROCOR (U.K.) LTD.
REGISTERED BY – C.M. & E.E. (B.R.B.) DERBY
YEAR BUILT – 1968
REGISTRATION Nos. – 58681 – 58780
OWNERS Nos. – 661 – 780

ISSUE 2
EX. P.O. DIAGRAM 6/694 (ALLOCATED.)

46 tonnes G.L.W TANK WAGON-CAUSTIC SODA LIQUOR

TTO49F

EXCESS LENGTH 4	H	M	L	E
tonnes	46	46	13	13
VB	0	0	0	0
AB	23	23	8	8
RA	8	8	1	1
MAX. SPEED	60	60	45	45

TOPS CODE										
CARKND		AARKND			OPERATING PANEL No					
T	T	B	T	T	B	A	1	5	1	5

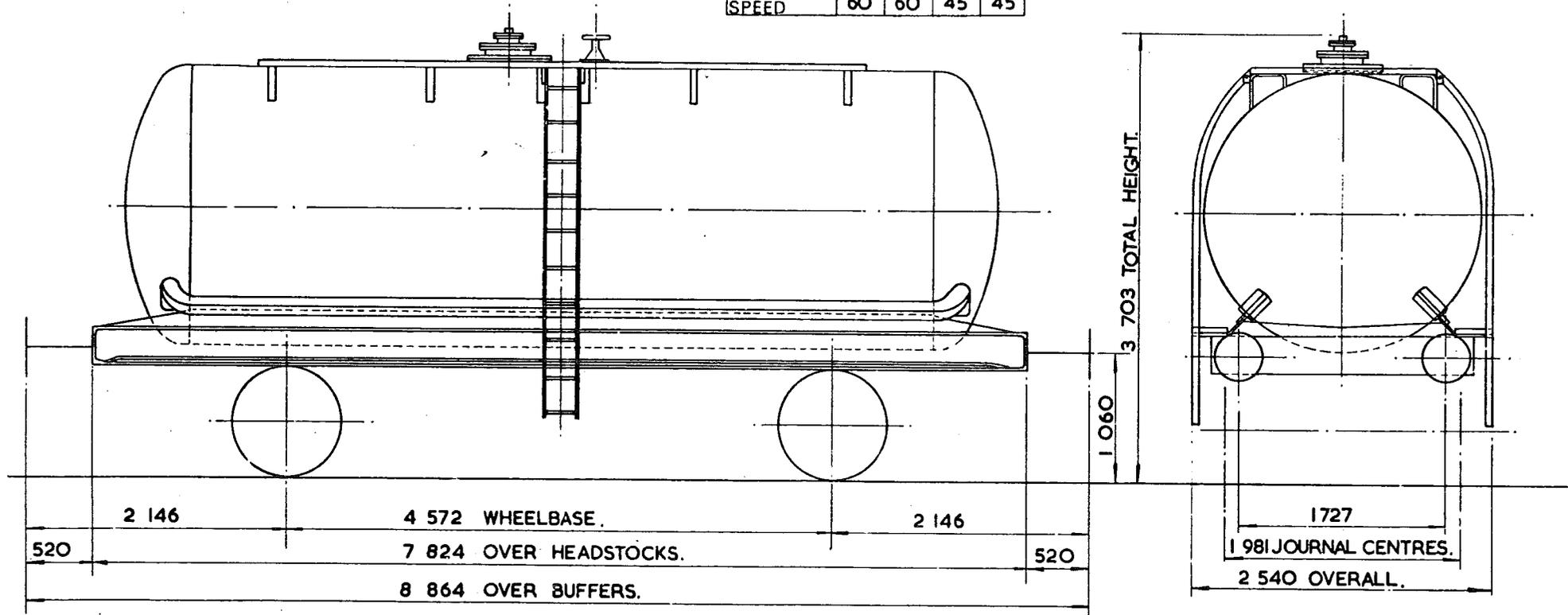

TARE	13 450kg
CARRYING CAPACITY	32 500kg.
CAPACITY	20 384 litres.
MAX SPEED	60 mile/h.
WHEELS	952 DIA.
JOURNALS	140 DIA. ROLLER BEARINGS.

BUFFERS	HYDRAULIC 406 DIA. HEADS.
COUPLINGS	INSTANTER
MIN. CURVE	31m.
GEN. ARRGT. DRG. No.	
BRAKE	AIR BLOCK, VACUUM PIPED & HAND LEVER
SUSPENSION	DOUBLE LINK.

BUILDER	STANDARD RAILWAY WAGON Co.
OWNER	PROCOR (U.K.) LTD.
REGISTERED BY	C. M. & E.E. (B.R.B.) DERBY.
YEAR BUILT	1966
REGISTRATION Nos.	58200,58201,58203,58212,58217,58221.
OWNERS Nos.	202,204 TO 211.

ISSUE 2
EX. P.O. DIAGRAM 6/691 (ALLOCATED).

46 tonnes GLW TANK WAGON SOLVENTS

TTO49G

EXCESS LENGTH	H	M	L	E
4				
tonnes	46	46	14	14
VB	0	0	0	0
AB	25	25	7	7
RA	8	8	1	1
MAX SPEED	60	60	60	60

TOPS CODE	
CARKND	AARKND
TTBTTRA1370	

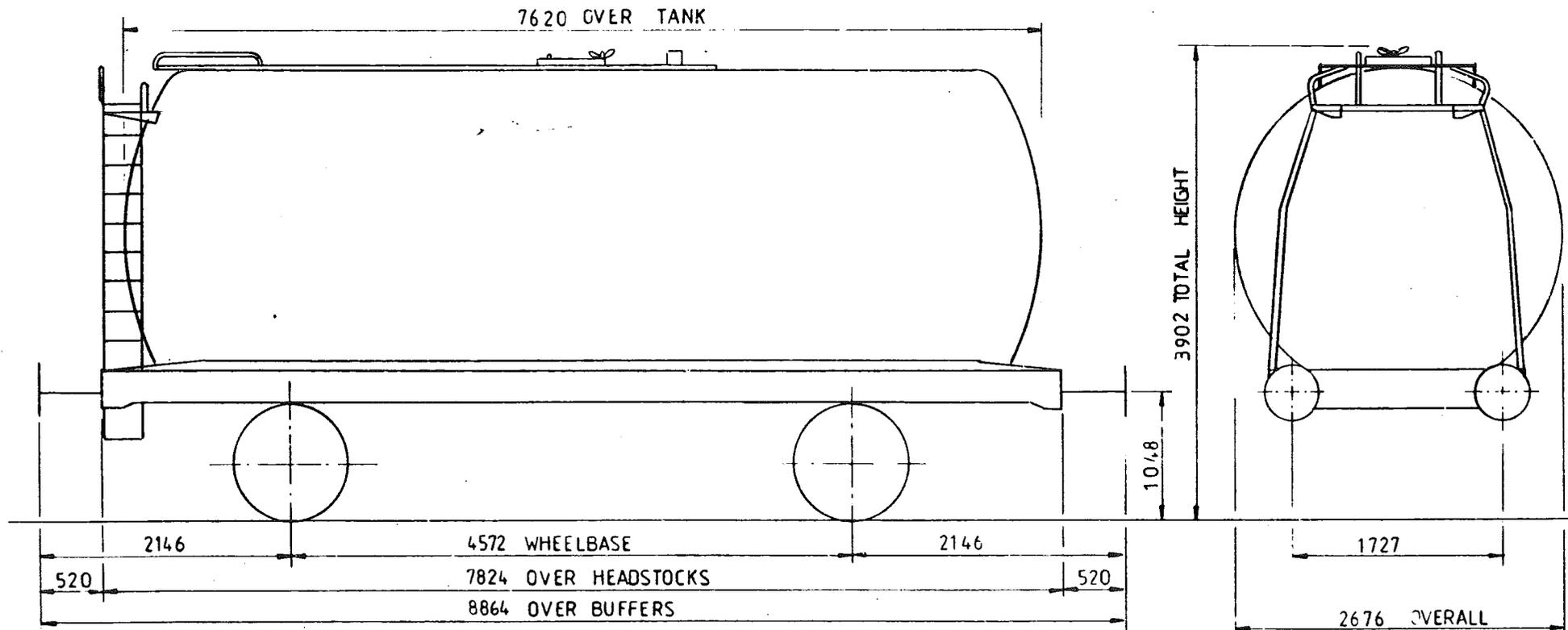

TARE	13 ⁵⁰ kg
CARRYING CAPACITY	32 ⁵⁰⁰ kg
CAPACITY	24352 Litres
MAX SPEED	60 mile/h
WHEELS	Ø 952
JOURNALS	Ø140 ROLLER BEARINGS

BUFFERS	HYDRAULIC Ø406 HEADS
COUPLINGS	INSTANTER
MIN CURVE	50 m
GEN ARRGT DRG No	
BRAKE	AIR BLOCK, VACUUM PIPE, HAND LEVER
SUSPENSION	FAT 26

ISSUE 1

46 tonne GLW TANK WAGON CAUSTIC LIQUOR

TT049H

EXCESS LENGTH	4	H	M	L	E
tonnes	46	46	14	14	
VB	0	0	0	0	
AB	26	26	10	10	
RA	8	8	1	1	
MAX SPEED	60	60	60	60	

TOPS CODE		
CARKND	AARKND	FRONT PANEL
T T B T T B A	1 4 8 8	

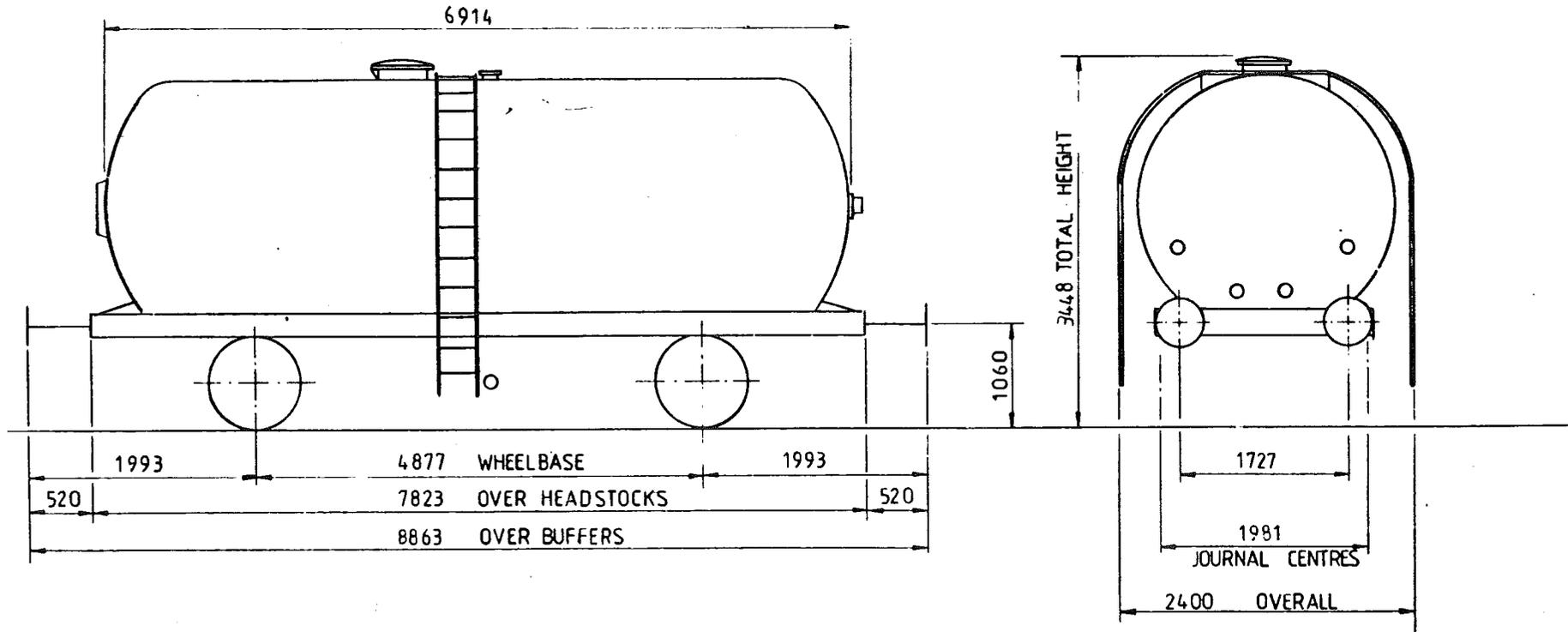

TARE	14 000	kg
CARRYING CAPACITY -	32 000	kg
CAPACITY -	20382	Litres
MAX SPEED	60	mile/h
WHEELS	φ 952	
JOURNALS	φ 140	ROLLER BEARINGS

BUFFERS	HYDRAULIC	φ 406	HEADS
COUPLINGS	INSTANTER		
MIN CURVE	50m		
GEN ARRGT DRG No			
BRAKE	AIR BLOCK,	VACUUM PIPED	HAND LEVER
SUSPENSION	DOUBLE LINK		

ISSUE 1

46 tonne GLW TANK WAGON SODIUM HYPOCHLORITE

TT049J

EXCESS LENGTH	4	H	M	L	E
tonnes	46	46	13	13	
VB	0	0	0	0	
AB	21	21	7	7	
RA	8	8	1	1	
MAX SPEED	60	60	45	45	

TOPS CODE		
CARKND	AARKND	...
T	T	B A 1 3 0 0

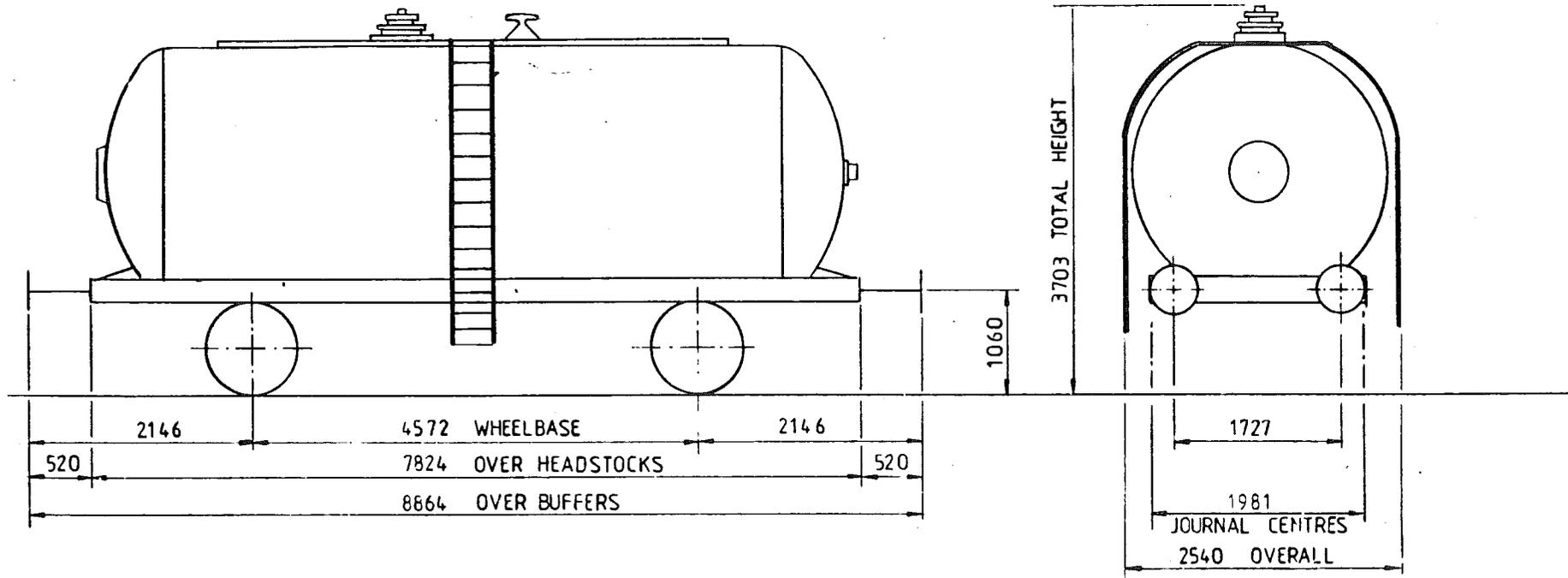

TARE	13 100	kg
CARRYING CAPACITY -	32 900	kg
CAPACITY -	28 503	Litres
MAX SPEED	60	mile/h
WHEELS	φ 952	
JOURNALS	φ 140	ROLLER BEARINGS

BUFFERS	HYDRAULIC	φ 406	HEADS
COUPLINGS	INSTANTER		
MIN CURVE	31m		
GEN ARRGT DRG No			
BRAKE	AIR BLOCK, VACUUM PIPED HAND LEVER		
SUSPENSION	DOUBLE LINK		

ISSUE 1

46 tonne GLW TANK WAGON SODIUM HYPOCHLORITE

TT049K

EXCESS LENGTH	4	H	M	L	E
tonnes	46	46	13	13	
VB	0	0	0	0	
AB	21	21	7	7	
RA	8	8	1	1	
MAX SPEED	60	60	45	45	

TOPS CODE	
CARKND	AARKND
TTBTTBA1300	

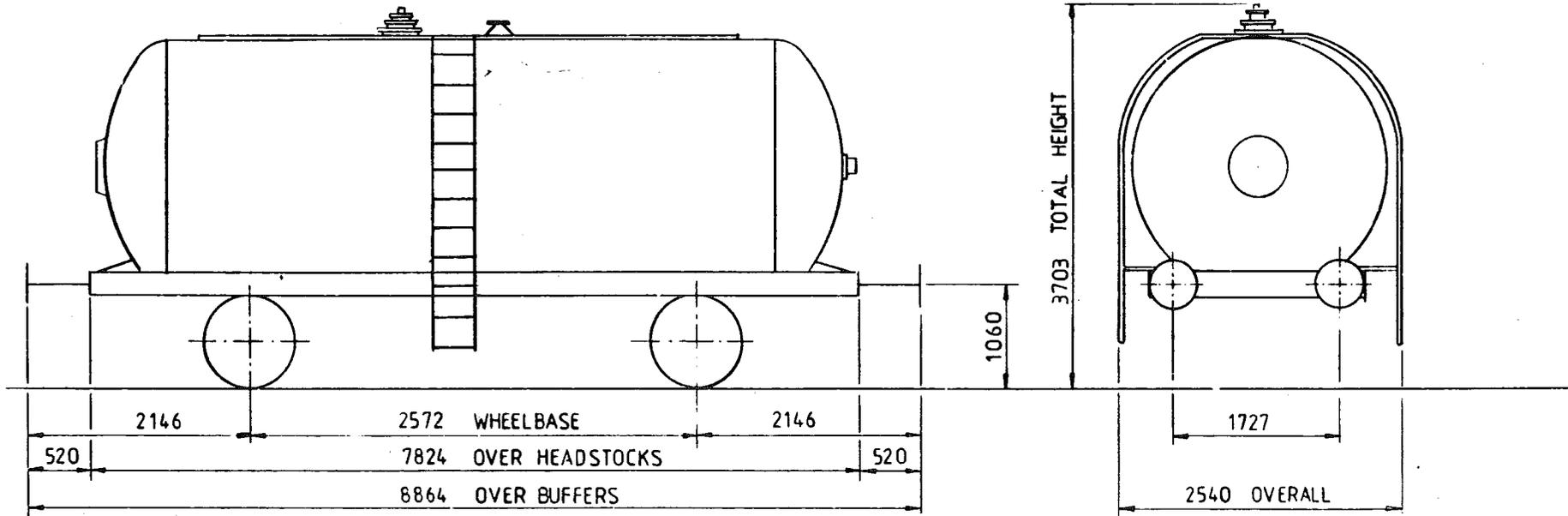

TARE	12 950	kg
CARRYING CAPACITY	33 000	kg
CAPACITY	26 730	Litres
MAX SPEED	60	mile/h
WHEELS	φ 952	
JOURNALS	φ 140	ROLLER BEARINGS

BUFFERS	HYDRAULIC	φ 406	HEADS
COUPLINGS	INSTANTER		
MIN CURVE	31m		
GEN ARRGT DRG No			
BRAKE	AIR BLOCK, VACUUM PIPED, HAND LEVER		
SUSPENSION	DOUBLE LINK		

ISSUE 1

EX PO DIAGRAM 6/692 (ALLOCATED)

4.6 tonne GLW TANK WAGON CAUSTIC LIQUOR

TT049L

EXCESS LENGTH	4	H	M	L	E
tonnes	46	46	13	13	
VB					
AB	23	23	8	8	
RA	8	8	1	1	
MAX SPEED	60	60	60	60	

TOPS CODE										
CARKND	AARKND									
T	T	A	T	T	A	A	1	5	7	3

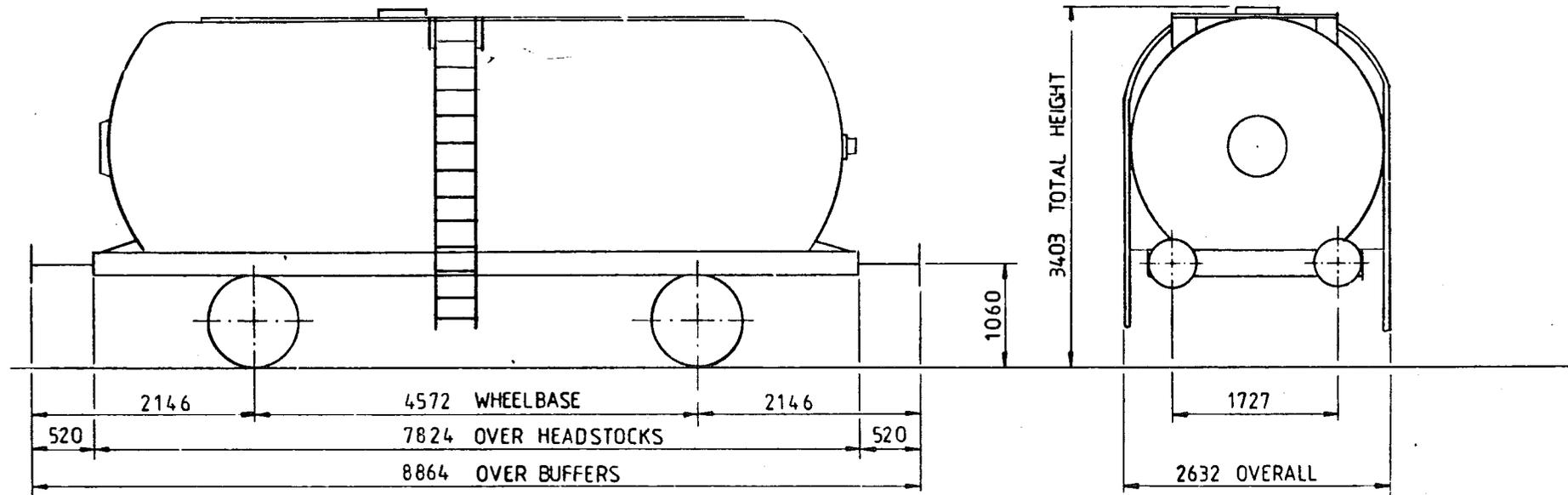

TARE	13 200	kg
CARRYING CAPACITY	32 800	kg
CAPACITY	22 325	Litres
MAX SPEED	60	mile/h
WHEELS	φ 952	
JOURNALS	φ 140	ROLLER BEARINGS

BUFFERS	HYDRAULIC	φ 406	HEADS
COUPLINGS	INSTANTER		
MIN CURVE	31m		
GEN ARRGT	DRG No		
BRAKE	AIR BLOCK,	HAND LEVER	
SUSPENSION	FRICTION CONTROLLED PARABOLIC SPRING		

ISSUE 1

46 tonne GLW TANK WAGON CAUSTIC LIQUOR

TT049M

EXCESS LENGTH	4	H	M	L	E
tonnes	46	46	13	13	
VB					
AB	23	23	8	8	
RA	8	8	1	1	
MAX SPEED	60	60	45	45	

TOPS CODE					
CARKND	AARKND	SERIAL	PARTS	DATE	BY
TT	ATA	ATA	A	157	4

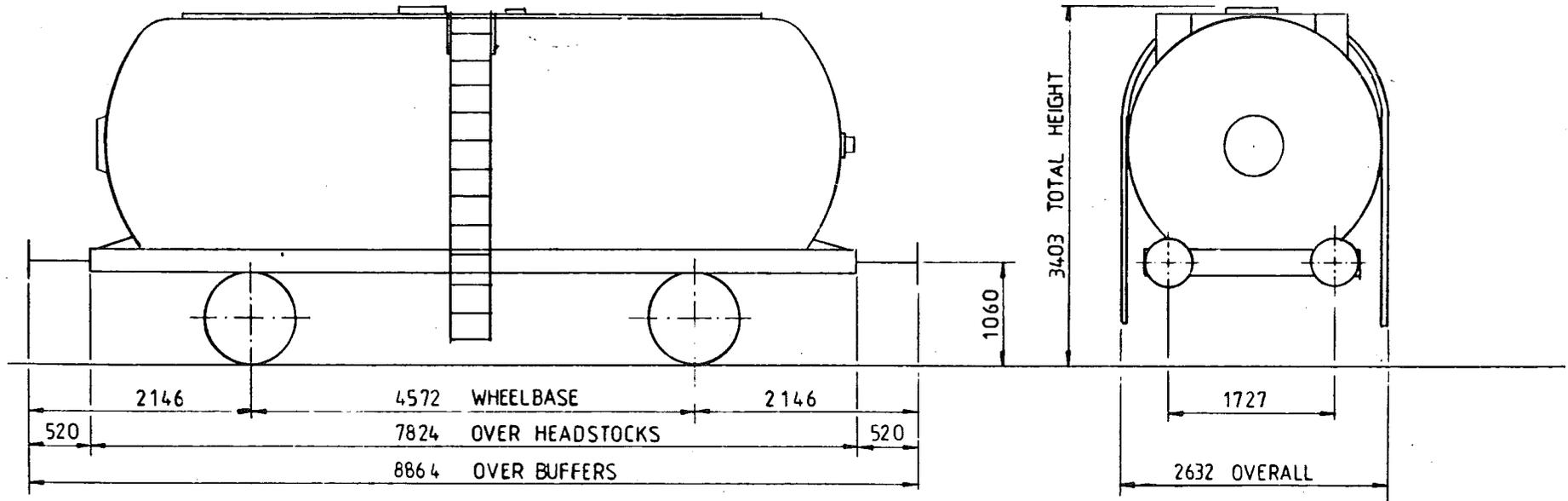

TARE	13200	kg
CARRYING CAPACITY -	32800	kg
CAPACITY -	22325	Litres
MAX SPEED	60	mile/h
WHEELS	φ 952	
JOURNALS	φ 140	ROLLER BEARINGS

BUFFERS	HYDRAULIC	φ 406	HEADS
COUPLINGS	INSTANTER		
MIN CURVE	31m		
GEN ARRGT DRG No			
BRAKE	AIR BLOCK,	HAND LEVER	
SUSPENSION	DOUBLE LINK		

ISSUE 1

46 tonne GLW TANK WAGON HYDROCHLORIC ACID

TT049U

EXCESS LENGTH 4	H	M	L	E
tonnes	46	46	13	13
VB				
AB	23	23	8	8
RA	8	8	1	1
MAX SPEED	60	60	45	45

TOPS CODE									
CARKND	AARKND	OPERATION							
T	T	A	T	A	A	1	5	1	5

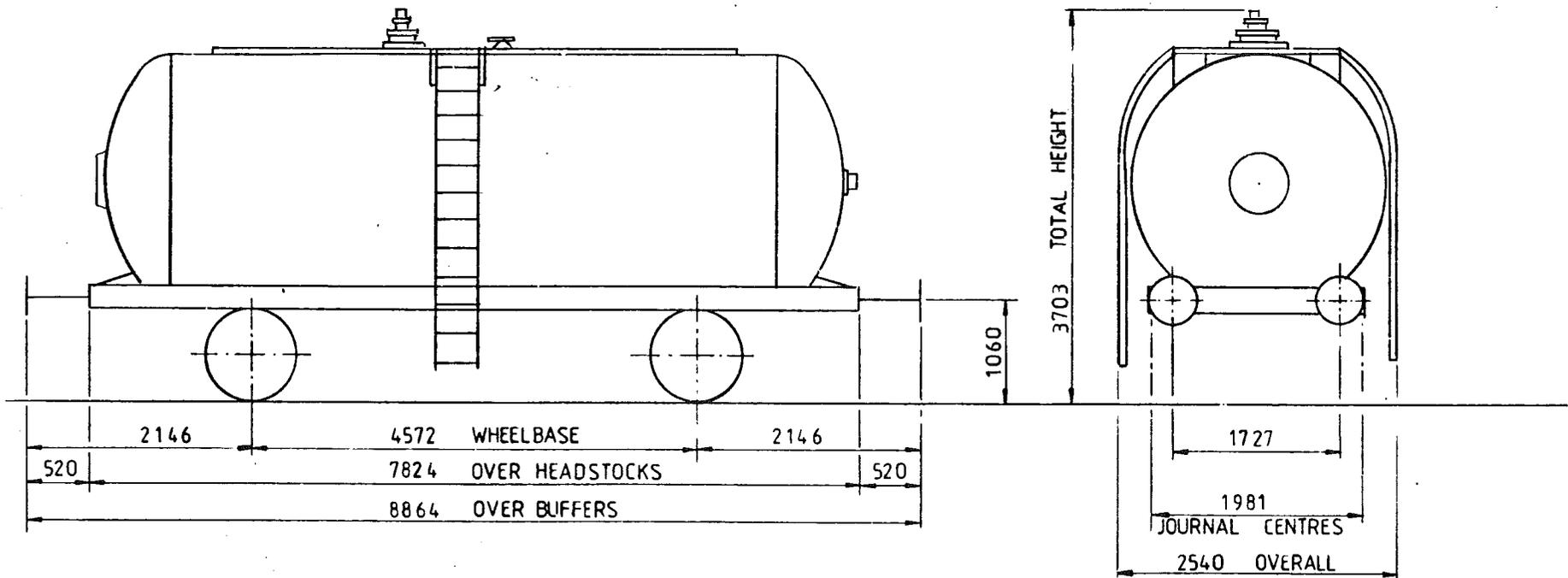

TARE	13 400 kg
CARRYING CAPACITY -	32 600 kg
CAPACITY -	28 503 Litres
MAX SPEED	60 mile/h
WHEELS	φ 952
JOURNALS	φ 140 ROLLER BEARINGS

BUFFERS	HYDRAULIC φ 406 HEADS
COUPLINGS	INSTANTER
MIN CURVE	31m
GEN ARRGT DRG No	
BRAKE	AIR BLOCK, HAND LEVER
SUSPENSION	DOUBLE LINK

ISSUE 1

EX PO. DIAGRAM 6/691 (ALLOCATED)

46 tonne GLW TANK WAGON CAUSTIC LIQUOR

TT049V

EXCESS LENGTH	4	H	M	L	E
tonnes	46	46	14	14	
VB	0	0	0	0	
AB	23	23	8	8	
RA	8	8	1	1	
MAX SPEED	60	60	60	60	

TOPS CODE									
CARKND		AARKND			PERMANENT PARTS				
T	T	B	T	B	A	1	6	2	4

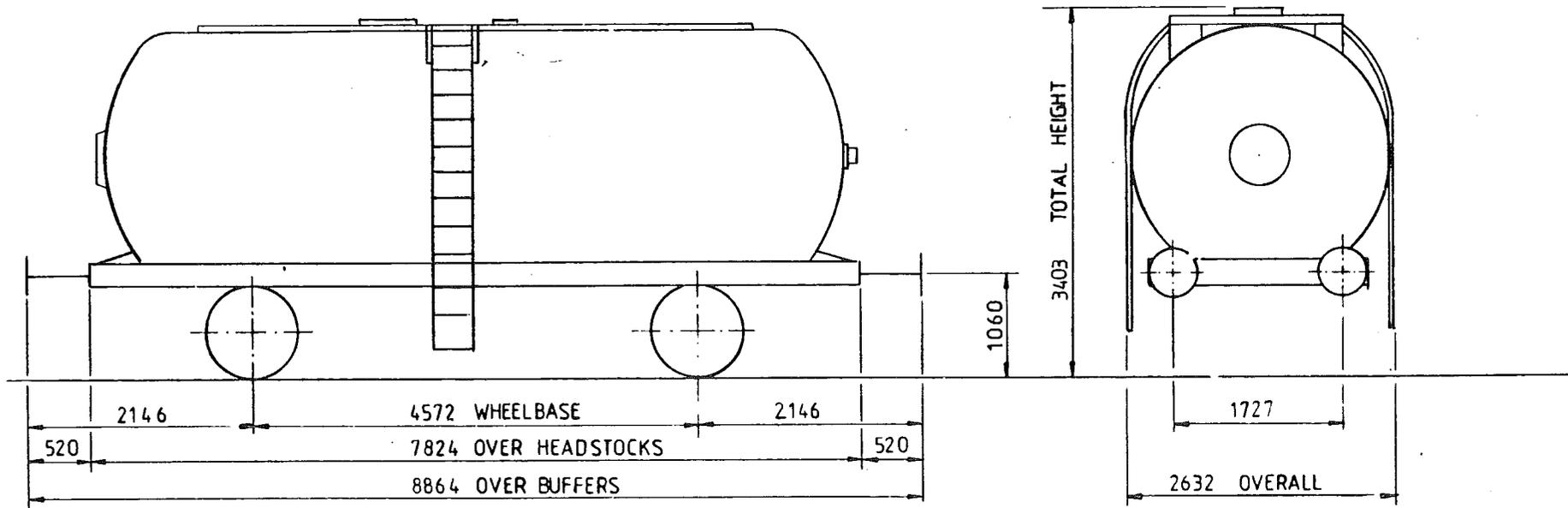

TARE	14 100 kg
CARRYING CAPACITY -	31 900 kg
CAPACITY -	21 800 Litres
MAX SPEED	60 mile/h
WHEELS	φ 952
JOURNALS	φ 140 ROLLER BEARINGS

BUFFERS	HYDRAULIC φ 406 HEADS
COUPLINGS	INSTANTER
MIN CURVE	31m
GEN ARRGT DRG No	
BRAKE	AIR BLOCK, VACUUM PIPED, HAND LEVER
SUSPENSION	FAT 26

ISSUE 1

46 tonne GLW TANK WAGON - HYDROCHLORIC ACID

LOT NUMBER	

TOPS INFORMATION						
AARKND	OPERATING	OPERATING SPEED		BRAKE FORCE DATA		EXCESS LENGTH
CARKND	PANEL No.	60 mile/h UP TO	46 tonne GLW	8t FORCE UP TO	31 tonne GLW	RA (GLW)
T T A A		mile/h ABOVE		23t FORCE ABOVE		DESIGN SHEET
						W1058

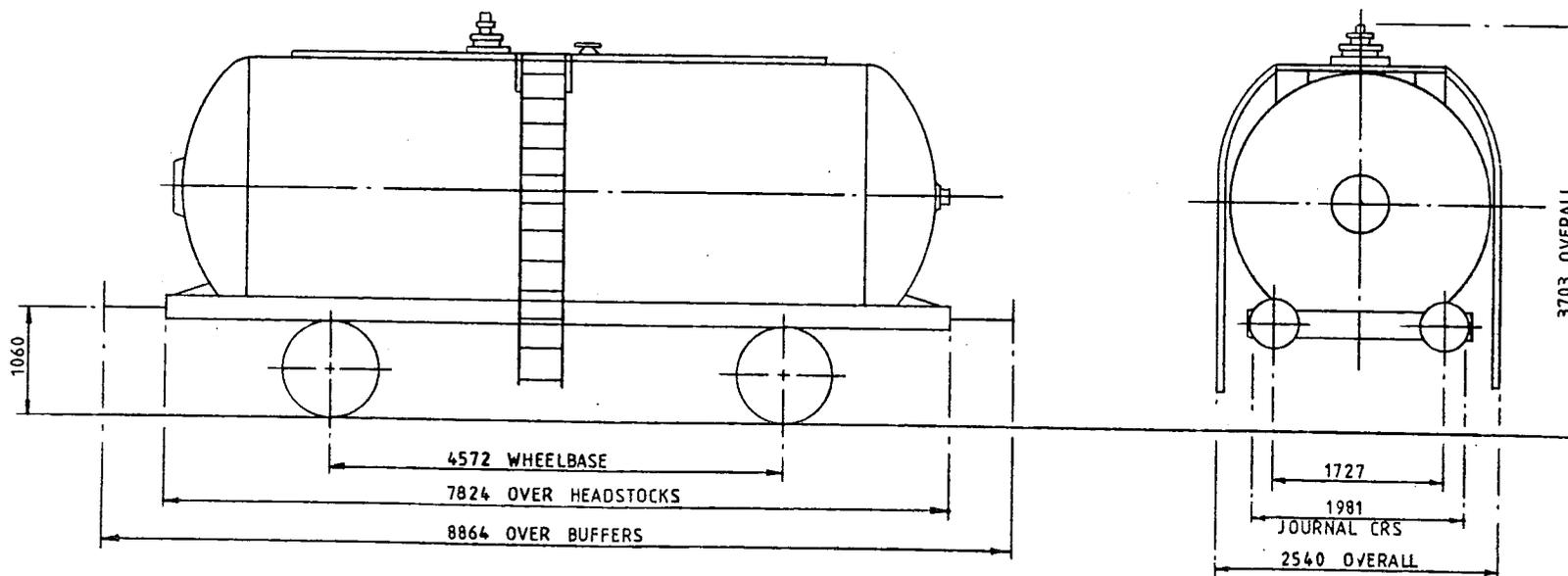

TARE-	13.100 Kg
CAPACITY, WEIGHT-	32.900 Kg
CAPACITY, VOLUME-	28.503 litres
MIN. CURVE-	31m
GEN. ARRGT. DRG. NO.-	

BRAKE-	AIR BLOCK & HAND LEVER
SUSPENSION-	DOUBLE LINK & PARABOLIC SPRING
COUPLINGS-	INSTANTER
BUFFERS-	HYDRAULIC 406 DIA
WHEELS-	952 DIA
JOURNALS-	140 DIA ROLLER BEARINGS

ISSUE 1

46 tonne GLW TANK WAGON - CAUSTIC SODA LIQUOR

LOT NUMBER	

TOPS INFORMATION											
AARKND		OPERATING		OPERATING SPEED			BRAKE FORCE DATA		EXCESS LENGTH	RA (GLW)	DESIGN SHEET
CARKND		PANEL No.		60 mile/h UP TO 46 tonne GLW			8t FORCE UP TO 31tonne GLW				
T	T	B	A						4	9	W1091

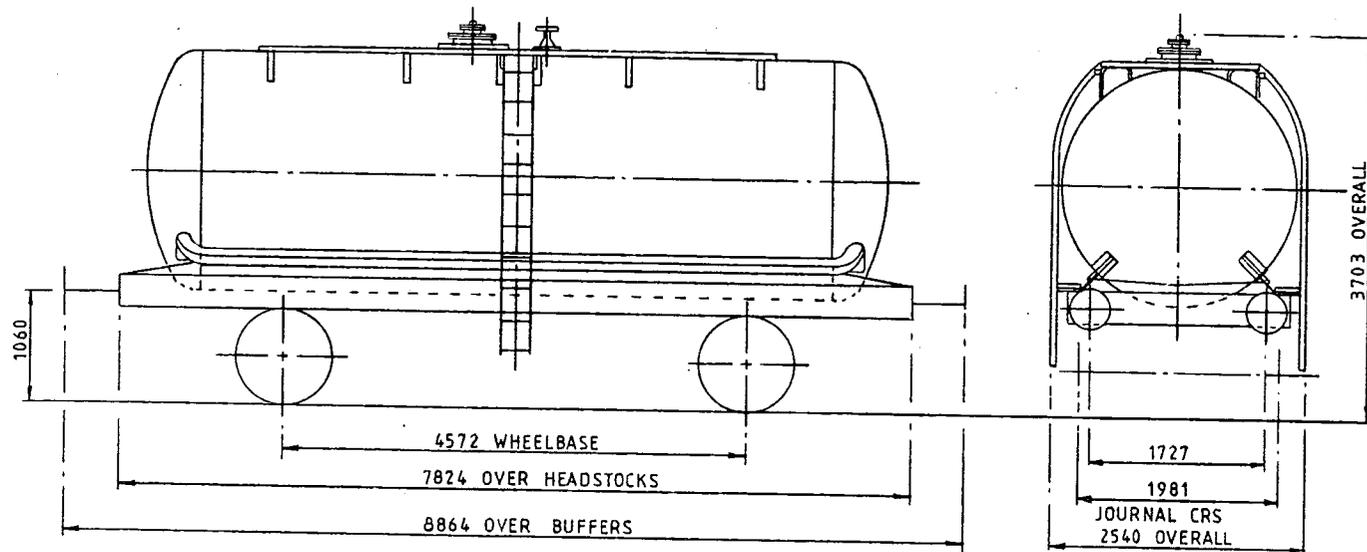

TARE-	13,400 Kg
CAPACITY, WEIGHT-	32,600 Kg
CAPACITY, VOLUME-	20,384 litres
MIN. CURVE-	31 m
GEN. ARRGT. DRG. NO.-	

BRAKE-	AIR BLOCK, VAC. PIPE, HAND LEVER
SUSPENSION-	DOUBLE LINK & PARABOLIC SPRING
COUPLINGS-	INSTANTER
BUFFERS-	HYDRAULIC 406 DIA HEADS
WHEELS-	952 DIA
JOURNALS-	140 DIA ROLLER BEARINGS

ISSUE 1

46 tonne GLW TANK WAGON - SODIUM HYPOCHLORITE

LOT NUMBER	

TOPS INFORMATION						
AARKND	OPERATING	OPERATING SPEED		BRAKE FORCE DATA		EXCESS LENGTH
CARKND	PANEL No.	60 mile/h UP TO	46 tonne GLW	7t FORCE UP TO	31 tonne GLW	4
T T B A		mile/h ABOVE		21t FORCE ABOVE		9
						WI400

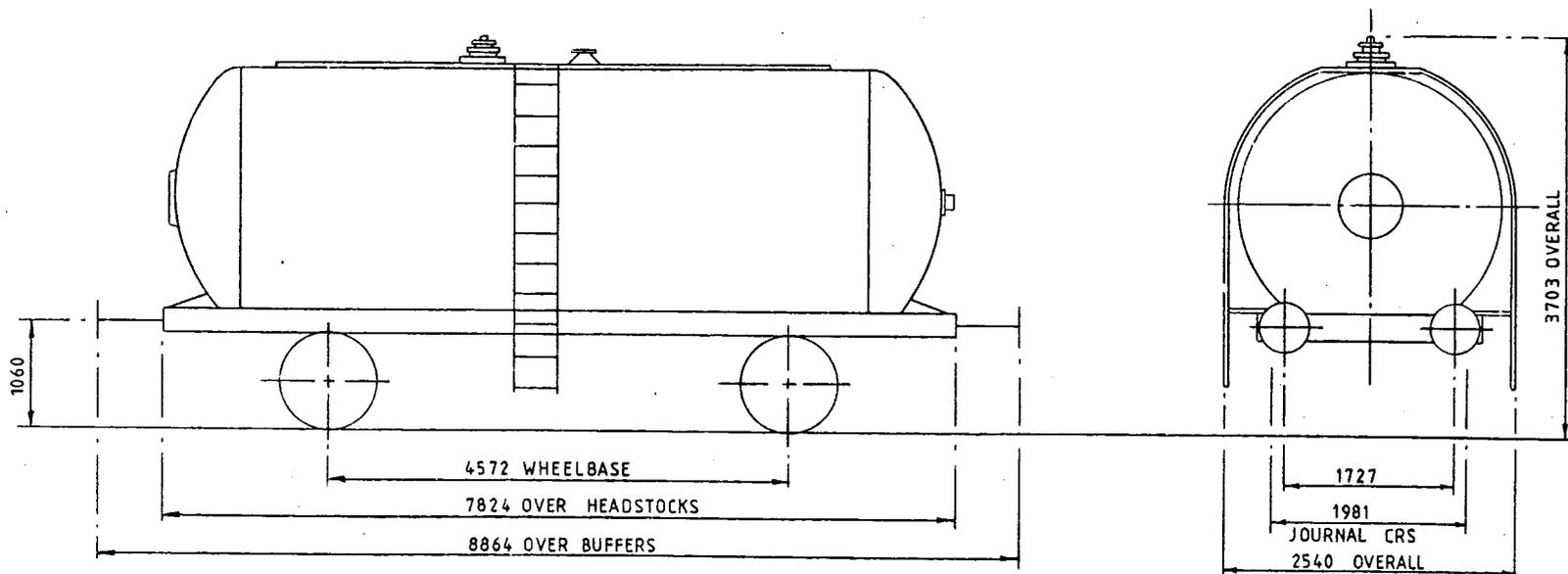

TARE-	12.600 Kg
CAPACITY, WEIGHT-	33.400 Kg
CAPACITY, VOLUME-	28.503 litres
MIN. CURVE-	31m
GEN. ARRGT. DRG. NO.-	

BRAKE-	AIR BLOCK, VAC. PIPE, HAND LEVER
SUSPENSION-	DOUBLE LINK & PARABOLIC SPRING
COUPLINGS-	INSTANTER
BUFFERS-	HYDRAULIC 406 DIA
WHEELS-	952 DIA
JOURNALS-	140 DIA ROLLER BEARINGS

ISSUE 1

46 tonne GLW TANK WAGON - SODIUM HYPOCHLORITE

LOT NUMBER	

TOPS INFORMATION									
AARKND	OPERATING		OPERATING SPEED		BRAKE FORCE DATA		EXCESS LENGTH	RA (GLW)	DESIGN SHEET
CARKND	PANEL No.		60 mile/h UP TO	46 tonne GLW	7t FORCE UP TO	31 tonne GLW			
T T B A			60 mile/h ABOVE		21t FORCE ABOVE		4	9	W1401

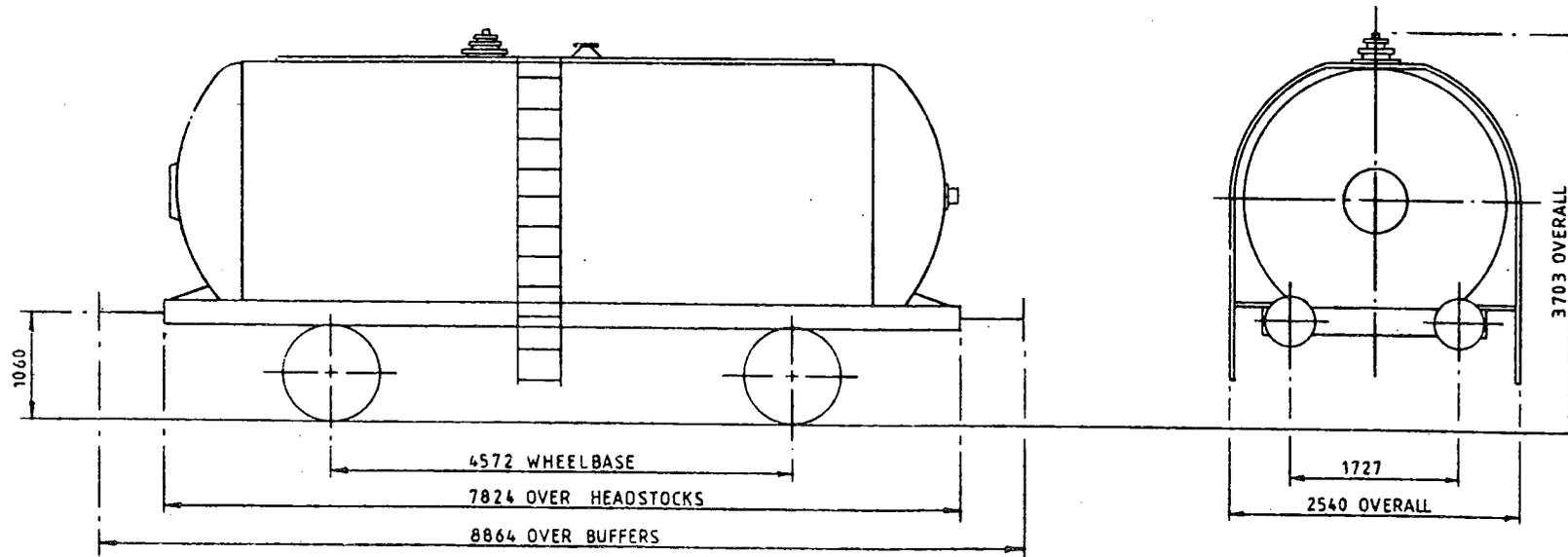

TARE-	12,800 Kg
CAPACITY, WEIGHT-	33,200 Kg
CAPACITY, VOLUME-	26,730 litres
MIN. CURVE-	31m
GEN. ARRGT. DRG. NO.-	

BRAKE-	AIR BLOCK, VAC. PIPE, HAND LEVER
SUSPENSION-	DOUBLE LINK & PARABOLIC SPRING
COUPLINGS-	INSTANTER
BUFFERS-	HYDRAULIC 406 DIA
WHEELS-	952 DIA
JOURNALS-	140 DIA ROLLER BEARINGS

ISSUE 1

46 tonnes G.L.W. TANK WAGON

TTO51B

EXCESS LENGTH	4	H	M	L	E
tonnes	46	46	16	16	
VB	0	0	0	0	
AB	22	22	10	10	
RA	8	8	1	1	
MAX. SPEED	60	60	45	45	

TOPS CODE										
CARKND		AARKND			OPERATING PANEL No					
T	T	B	T	T	B	A	1	5	3	6

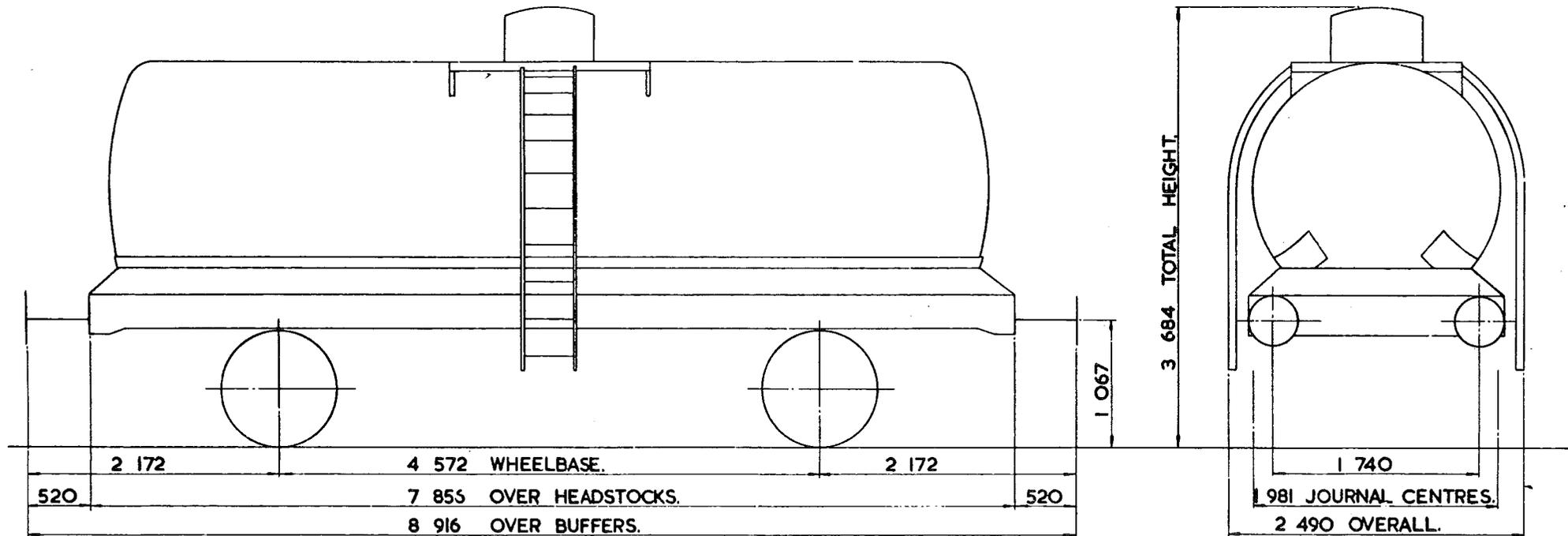

TARE - 16 250 kg
CARRYING CAPACITY - 29 700 kg.
CAPACITY - 24221 litres.
MAX. SPEED - 60 mile/h.
WHEELS - 952 DIA.
JOURNALS - 140 DIA. ROLLER BEARING.

BUFFERS - HYDRAULIC 406 DIA. HEADS.
COUPLINGS - INSTANTER.
MIN. CURVE - 31 m.
GEN. ARRGT. DRG. No. -
BRAKE - AIR BLOCK, VACUUM PIPED & HAND LEVER.
SUSPENSION - DOUBLE LINK.

BUILDER - CHARLES ROBERTS.
OWNER - TIGER RAILCAR LEASING.
REGISTERED BY - C. M. & E. E. (B. R. B.) DERBY.
YEAR BUILT - 1966/67.
REGISTRATION Nos. - 51561 TO 51585.
OWNERS Nos. - A 561 TO A 585.

46 tonnes G L W TANK WAGON

TTO51C

EXCESS LENGTH	4	H	M	L	E
tonnes	46	46	16	16	
VB	0	0	0	0	
AB	23	23	9	9	
RA	8	8	1	1	
MAX. SPEED	60	60	45	60	

TOPS CODE									
CARKND			AARKND			OPERATING PANEL No			
T	T	B	T	T	B	A	I	S	3 7

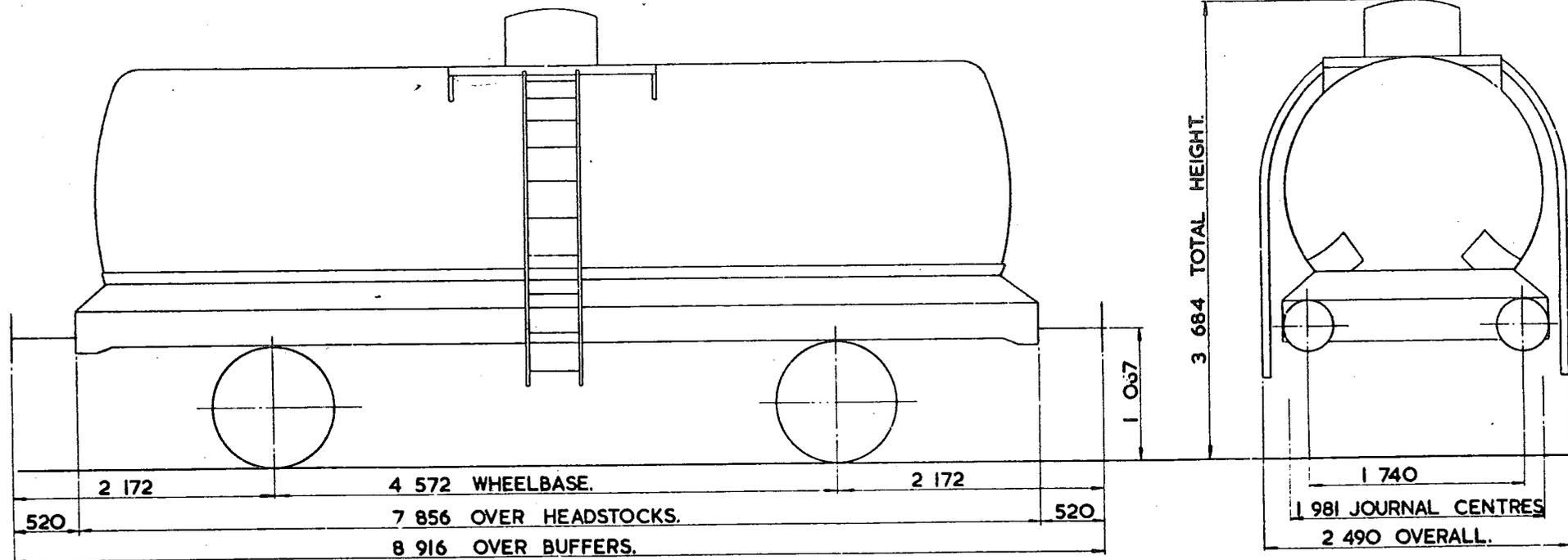

TARE - 16 250 kg.
CARRYING CAPACITY - 29 700 kg.
CAPACITY - 21 889 litres.
MAX SPEED - 60 mile/h.
WHEELS - 952 DIA.
JOURNALS - 140 DIA. ROLLER BEARINGS.

BUFFERS - HYDRAULIC 406 DIA. HEADS.
COUPLINGS - INSTANTER.
MIN. CURVE 31 m.
GEN. ARRGT. DRG No -
BRAKE - AIR BLOCK, VACUUM PIPE & HAND LEVER.
SUSPENSION - DOUBLE LINK.

BUILDER - CHARLES ROBERTS.
OWNER - TIGER RAILCAR LEASING.
REGISTERED BY - C. M. & E. E. (B. R. B.) DERBY.
YEAR BUILT - 1967/8.
REGISTRATION Nos. - 51649 - 51723.
OWNERS Nos. - A 649 - A723.

ISSUE 2
EX. P.O. DIAGRAM 6/766 (ALLOCATED.)

46 tonnes G.L.W. TANK WAGON

TT05ID

EXCESS LENGTH	4	H	M	L	E
tonnes	46	46	17	17	
VB	0	0	0	0	
AB	23	23	9	9	
RA	8	8	1	1	
MAX. SPEED	60	60	45	45	

TOPS CODE		
CARKND	AARKND	OPERATING PANEL No
T T B	T T B A	1 5 3 8

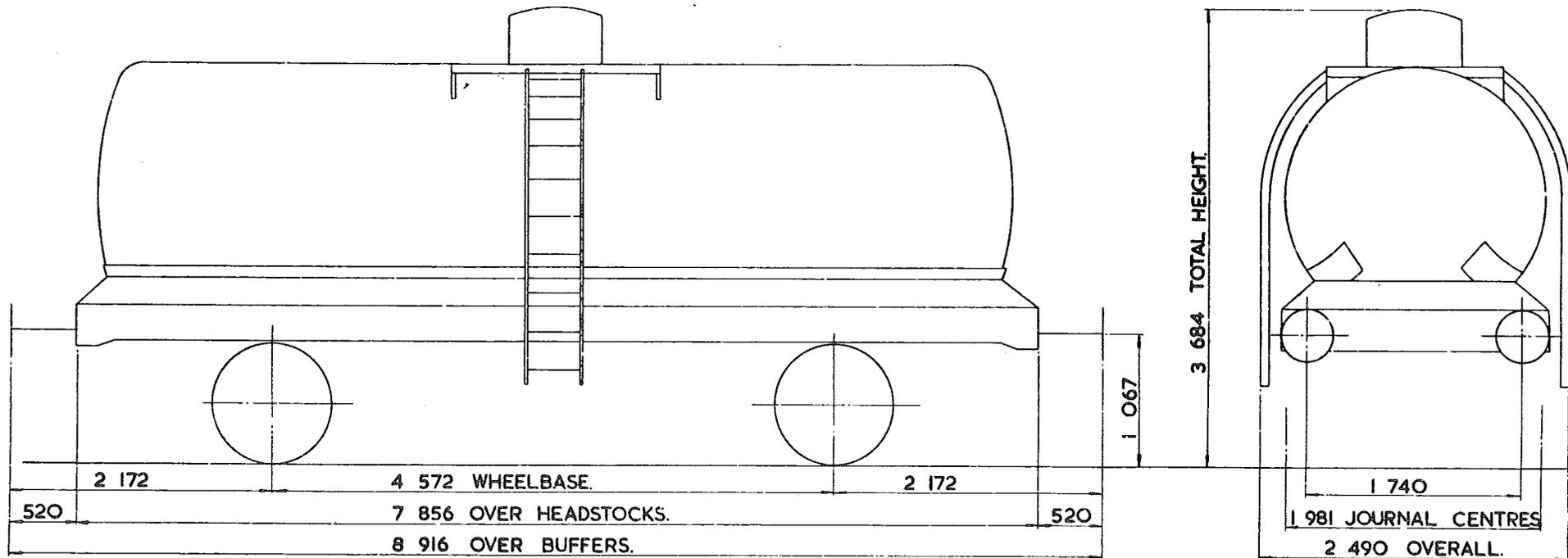

WE - 16750 kg.
CARRYING CAPACITY - 29 200 kg.
CAPACITY - 24221 litres.
MAX. SPEED - 60 mile/h.
WHEELS - 952 DIA.
JOURNALS - 140 ROLLER BEARINGS.

BUFFERS - HYDRAULIC 406 DIA. HEADS.
COUPLINGS - INSTANTER.
MIN. CURVE - 31 m.
GEN ARRGT DRG. No -
BRAKE - AIR BLOCK, VACUUM PIPED & HAND LEVER.
SUSPENSION - DOUBLE LINK.

BUILDER - CHARLES ROBERTS.
OWNER - TIGER RAILCAR LEASING.
REGISTERED BY - C.M. & E.E. (B.R.B.) DERBY.
YEAR BUILT - 1969.
REGISTRATION Nos. - 51410 TO 51434
OWNERS Nos. -

ISSUE 1

EX. P.O. DIAGRAM 6/761 (ALLOCATED)

46tonne GLW TANK WAGON

LOT NUMBER	

TOPS INFORMATION									
AARKND	OPERATING		OPERATING SPEED		BRAKE FORCE DATA		EXCESS LENGTH	RA (GLW)	DESIGN SHEET
CARKND	PANEL No.		60 mile/h UP TO	46 tonne GLW	9 t FORCE UP TO	31 tonne GLW			
T T A A			60 mile/h ABOVE		23 t FORCE ABOVE		4	8	W1023

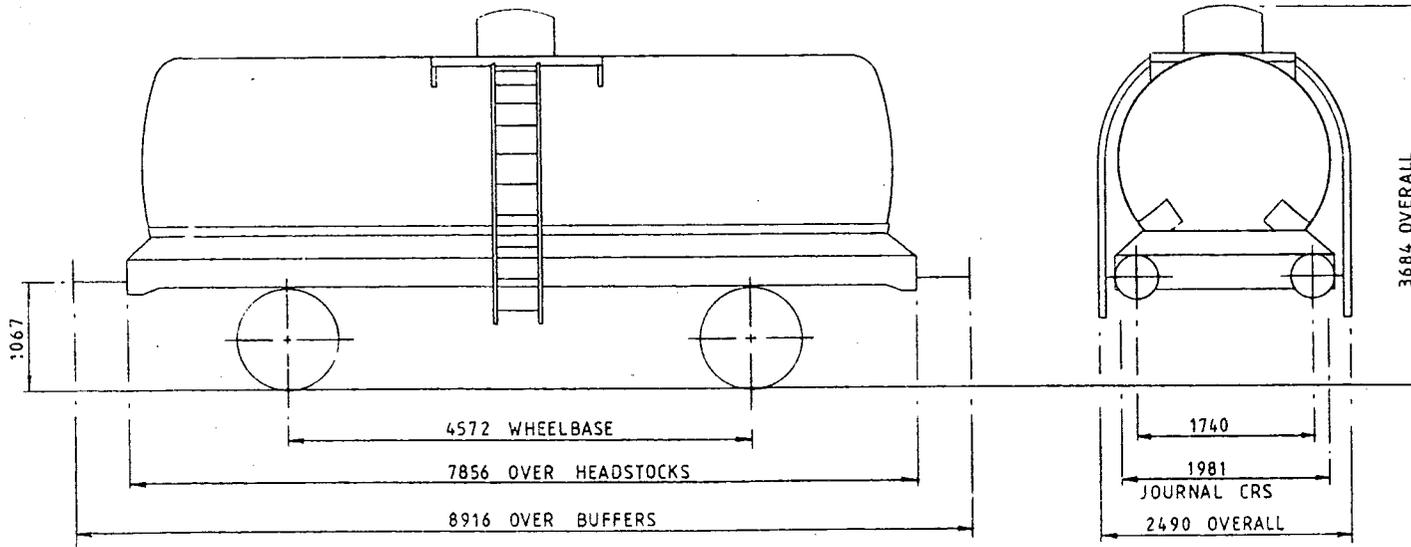

TARE-	16.750 Kg
CAPACITY, WEIGHT-	29.200 Kg
CAPACITY, VOLUME-	24.221 litres
MIN. CURVE-	31 m
GEN. ARRGT. DRG. NO.-	

BRAKE-	AIR BLOCK & HAND LEVER
SUSPENSION-	SINGLE LINK & PARABOLIC SPRING
COUPLINGS-	INSTANTER
BUFFERS-	HYDRAULIC 406 DIA HEADS
WHEELS-	952 DIA
JOURNALS-	140 DIA ROLLER BEARINGS

ISSUE 1

46 tonne GLW TANK WAGON NITRIC ACID

TT051H

EXCESS LENGTH	4	H	M	L	E
tonnes	46	46	13	13	
VB					
AB	23	23	9	9	
RA	8	8	1	1	
MAX SPEED	60	60	60	60	

TOPS CODE				
CARKND	AARKND	FINISH	PAVE	
T	T	A	A	1 6 2 9

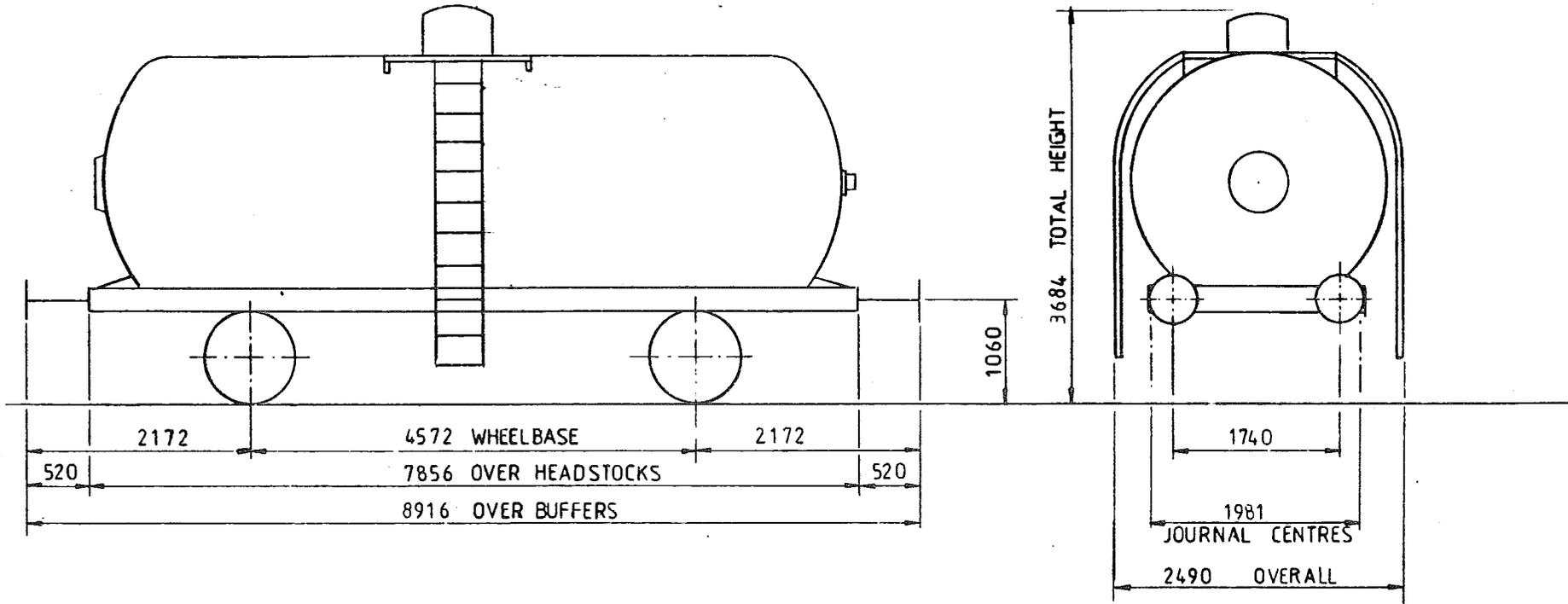

TARE	13 ²⁵⁰ kg
CARRYING CAPACITY -	32 ⁸⁰⁰ kg
CAPACITY -	24975 Litres
MAX SPEED	60 mile/h
WHEELS	φ 952
JOURNALS	φ 140 ROLLER BEARINGS

BUFFERS	HYDRAULIC φ 406 HEADS
COUPLINGS	INSTANTER
MIN CURVE	31m
GEN ARRGT DRG No	
BRAKE	AIR BLOCK, HAND LEVER
SUSPENSION	F A T 28

ISSUE 1

EX PO DIAGRAM 6/766(ALLOCATED)

46 tonne GLW TANK WAGON- CHLORINE.

TT051J

EXCESS LENGTH	4	H	M	L	E
tonnes	46	46	16	16	
VB					
AB	23	23	9	9	
RA	8	8	1	1	
MAX SPEED	60	60	60	60	

TOPS CODE					
CARKND	AARKND	WAGON	WAGON	WAGON	WAGON
T	T	A	T	A	A 1 6 2 9

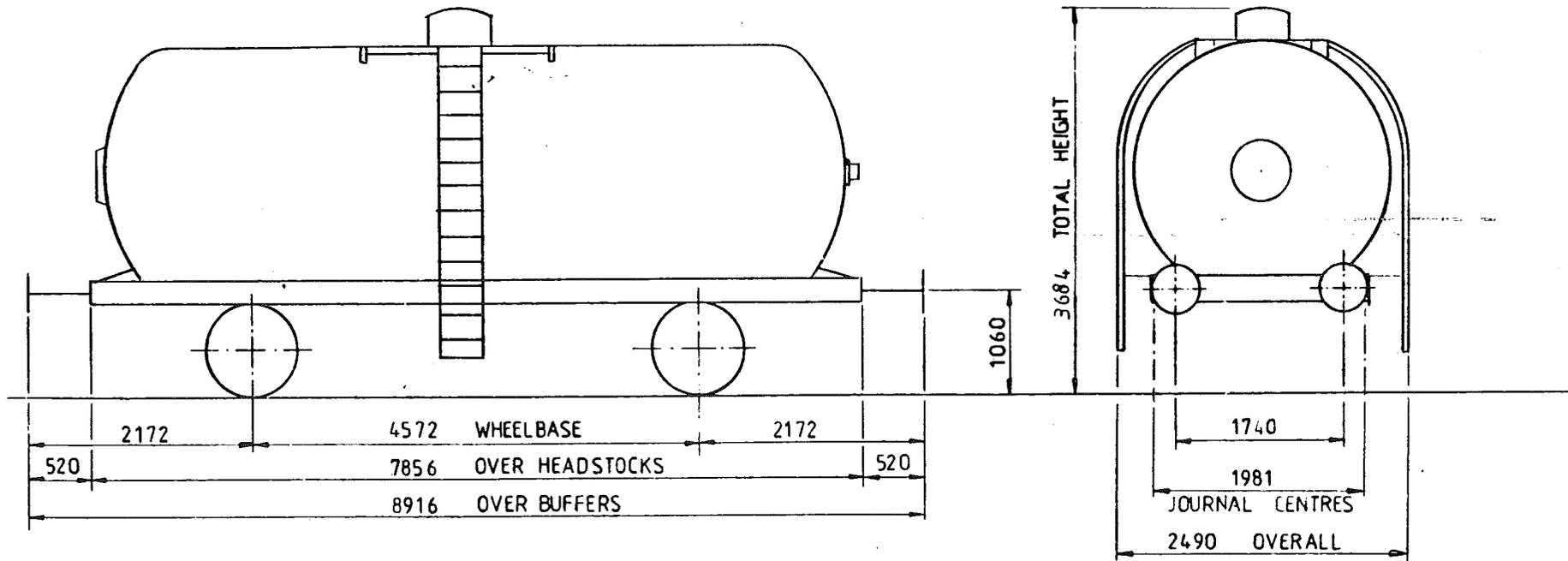

TARE	16 100	kg
CARRYING CAPACITY -	29 900	kg
CAPACITY -	21889	Litres
MAX SPEED	60	mile/h
WHEELS	φ 952	
JOURNALS	φ 140	ROLLER BEARINGS

BUFFERS	HYDRAULIC	φ 406	HEADS
COUPLINGS	INSTANTER		
MIN CURVE	31m		
GEN ARRGT DRG No			
BRAKE	AIR BLOCK,	HAND LEVER	
SUSPENSION	FAT 28		

ISSUE 1

EX PO. DIAGRAM 6/766(ALLOCATED)

4.6 tonne GLW TANK WAGON CHLORINE

TT051K

EXCESS LENGTH	4	H	M	L	E
tonnes		46	46	16	16
B		0	0	0	0
AB		22	22	10	10
BA		8	8	1	1
MAX SPEED		60	60	45	45

TOPS CODE	
CARKND	AARKND
T T B T I B A 1 5 3 6	

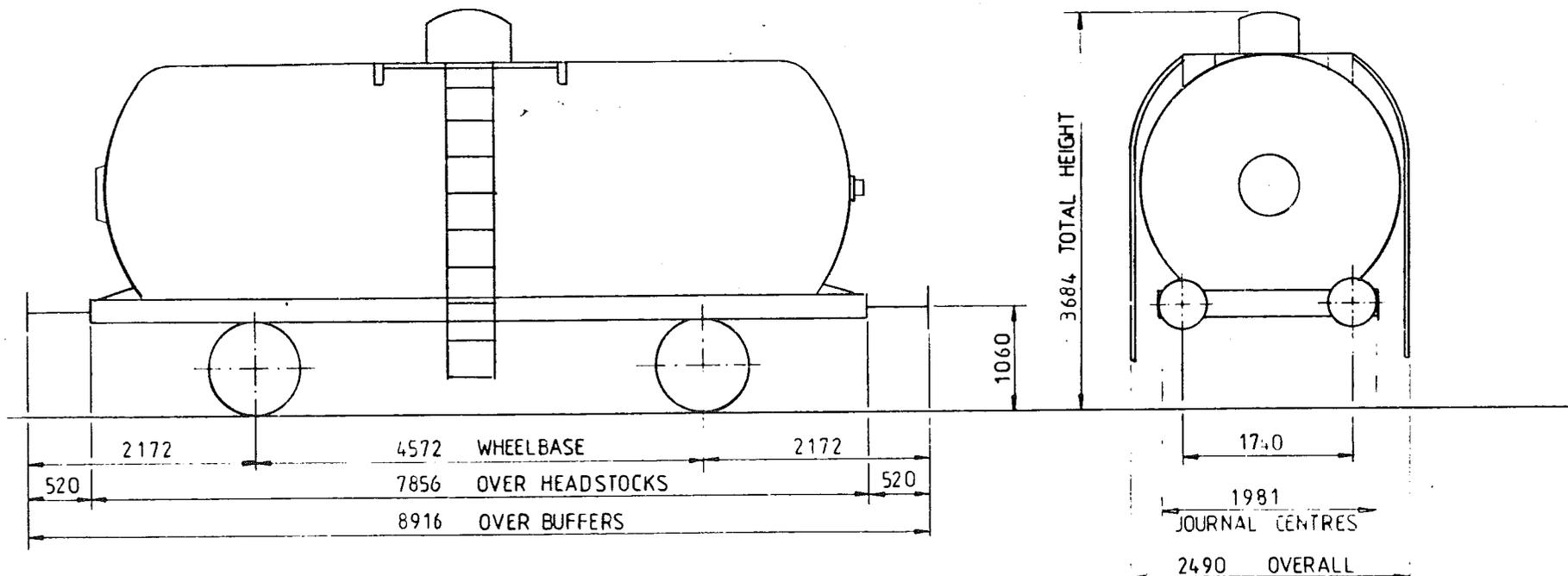

TARE	16250	kg
CARRYING CAPACITY -	29700	kg
CAPACITY -	24221	Litres
MAX SPEED	60	mile/h
WHEELS	Ø 952	
JOURNALS	Ø 140	ROLLER BEARINGS

BUFFERS	HYDRAULIC Ø 406 HEADS
COUPLINGS	INSTANTER
MIN CURVE	31m
GEN ARRGT DRG No.	
BRAKE	AIR BLOCK, VACUUM PIPED, HAND LEVER
SUSPENSION	DOUBLE LINK

ISSUE 1

EX PO. DIAGRAM 61764 (ALLOCATED)

46 tonne GLW TANK WAGON - SULPHURIC ACID

LOT NUMBER	

TOPS INFORMATION						
AARKND	OPERATING	OPERATING SPEED		BRAKE FORCE DATA		EXCESS LENGTH
CARKND	PANEL No.	60 mile/h UP TO	46 tonne GLW	10t FORCE UP TO	31 tonne GLW	4
T T A A		mile/h ABOVE		22t FORCE ABOVE		
						RA (GLW) 9
						DESIGN SHEET W1187

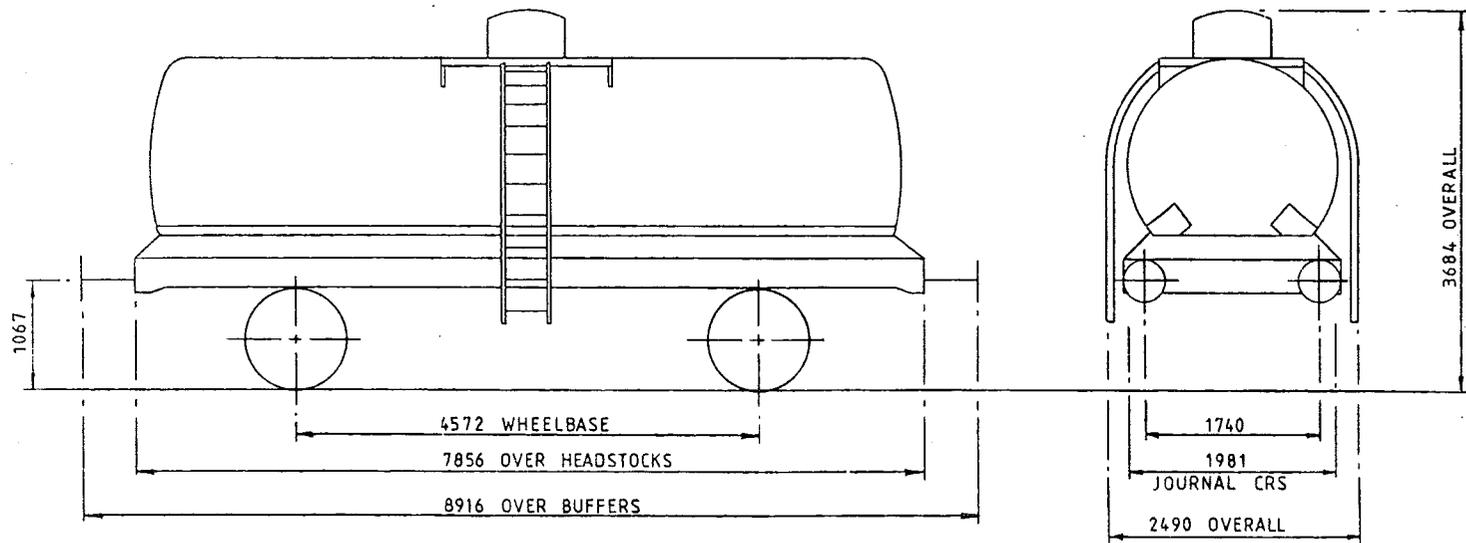

TARE-	15.200 Kg
CAPACITY, WEIGHT-	30.800 Kg
CAPACITY, VOLUME-	24.221 litres
MIN. CURVE-	31m
GEN. ARRGT. DRG. NO.-	

BRAKE-	AIR BLOCK & HAND LEVER
SUSPENSION-	DOUBLE LINK & PARABOLIC SPRING
COUPLINGS-	INSTANTER
BUFFERS-	HYDRAULIC 406 DIA HEADS
WHEELS-	952 DIA
JOURNALS-	140 DIA ROLLER BEARINGS

ISSUE 1

46 tonnes G.L.W. TANK WAGON - PHOSPHORIC ACID

TTO52A

EXCESS LENGTH	4	H	M	L	E
tonnes	46	46	13	13	
VB	0	0	0	0	
AB	21	17	7	7	
RA	8	8	1	1	
MAX SPEED	60	60	60	60	

TOPS CODE									
CARKND		AARKND			OPERATING PANEL				
T	T	B	T	T	B	A	8	8	4

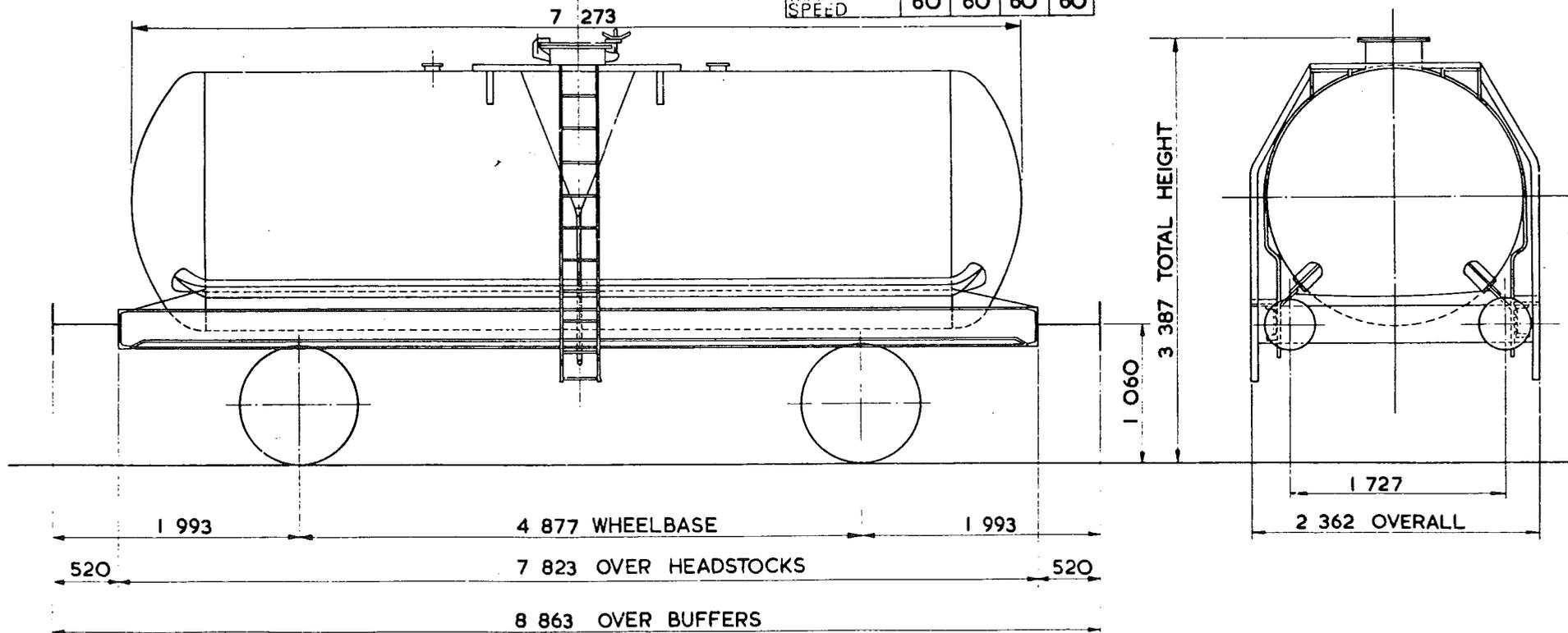

TARE - 16 750 kg
CARRYING CAPACITY - 33 300 kg
CAPACITY - 22 166 litres.
MAX. SPEED - 60 mile/h
WHEELS - 952 DIA.
JOURNALS - 140 DIA. ROLLER BEARINGS

BUFFERS - HYDRAULIC 406 DIA. HEADS
COUPLINGS - INSTANTER
MIN. CURVE - 31m.
GEN ARRGT DRG. No. -
BRAKE - AIR BLOCK, VACUUM PIPED & HAND LEVER
SUSPENSION - DOUBLE LINK

BUILDER - STANDARD RAILWAY WAGON Co.
OWNER - PROCOR (UK) LTD
REGISTERED BY - C.M. & E.E. (B.R.B.) DERBY
YEAR BUILT - 1968
REGISTRATION Nos. 58410 - 58909 (RANGE.)
OWNERS Nos. PA/01 - PA/24

ISSUE 2
EX. P.O. DIAGRAM 6/224 (ALLOCATED)

46 tonnes G.L.W. TANK WAGON - CAUSTIC LIQUOR

TTO53A

EXCESS LENGTH 4	H	M	L	E
tonnes	46	46	13	13
VB	0	0	0	0
AB	26	26	10	10
RA	8	8	1	1
MAX. SPEED	60	60	60	60

TOPS CODE							
CARKND		AARKND		OPERATING PANEL No			
T	T	B	T	T	B	A	I 4 8 8

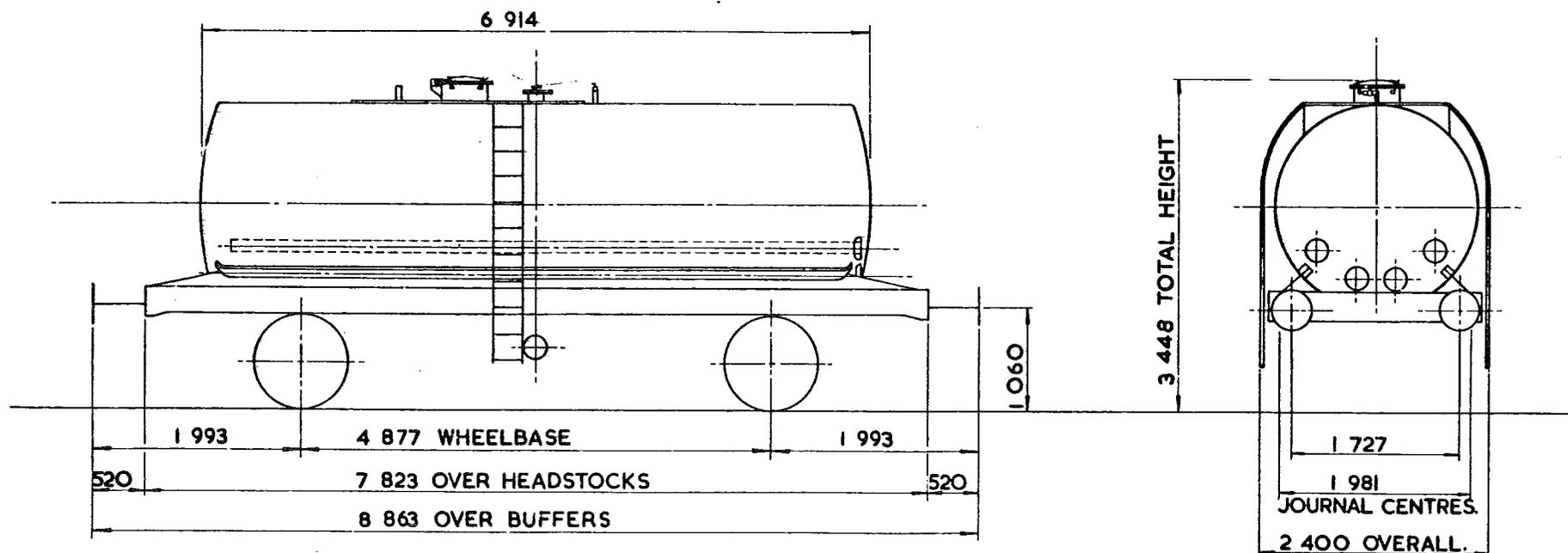

TARE - 13200kg.
CARRYING CAPACITY - 32800kg.
CAPACITY - 21671 litres.
MAX. SPEED - 60 mile/h.
WHEELS - 952 DIA.
JOURNALS - 140 DIA. ROLLER BEARINGS

BUFFERS - HYDRAULIC 406 DIA. HEADS.
COUPLINGS - INSTANTER
MIN. CURVE - 31m
GEN. ARRGT. DRG. No. -
BRAKE - AIR BLOCK, VACUUM PIPED & HAND LEVER.
SUSPENSION - DOUBLE LINK

BUILDER - STANDARD RAILWAY WAGON CO.
OWNER - PROCOR (UK.) LTD.
REGISTERED BY - C.M. & E.E. (B.R.B) DERBY.
YEAR BUILT - 1971/72
REGISTRATION Nos. - 58601 TO 58660
OWNERS Nos. - CUI TO CU60.

46 tonne G.L.W. TANK WAGON SULPHURIC ACID

TT 053B.

4	F	M	L	E
tonnes	46	46	13	13
VB	0	0	0	0
AB	26	26	10	10
RA	8	8	1	1
	60	60	60	60

TYPE CODE										
LARKND		AARKND								
T	T	B	T	T	B	A	1	4	8	8

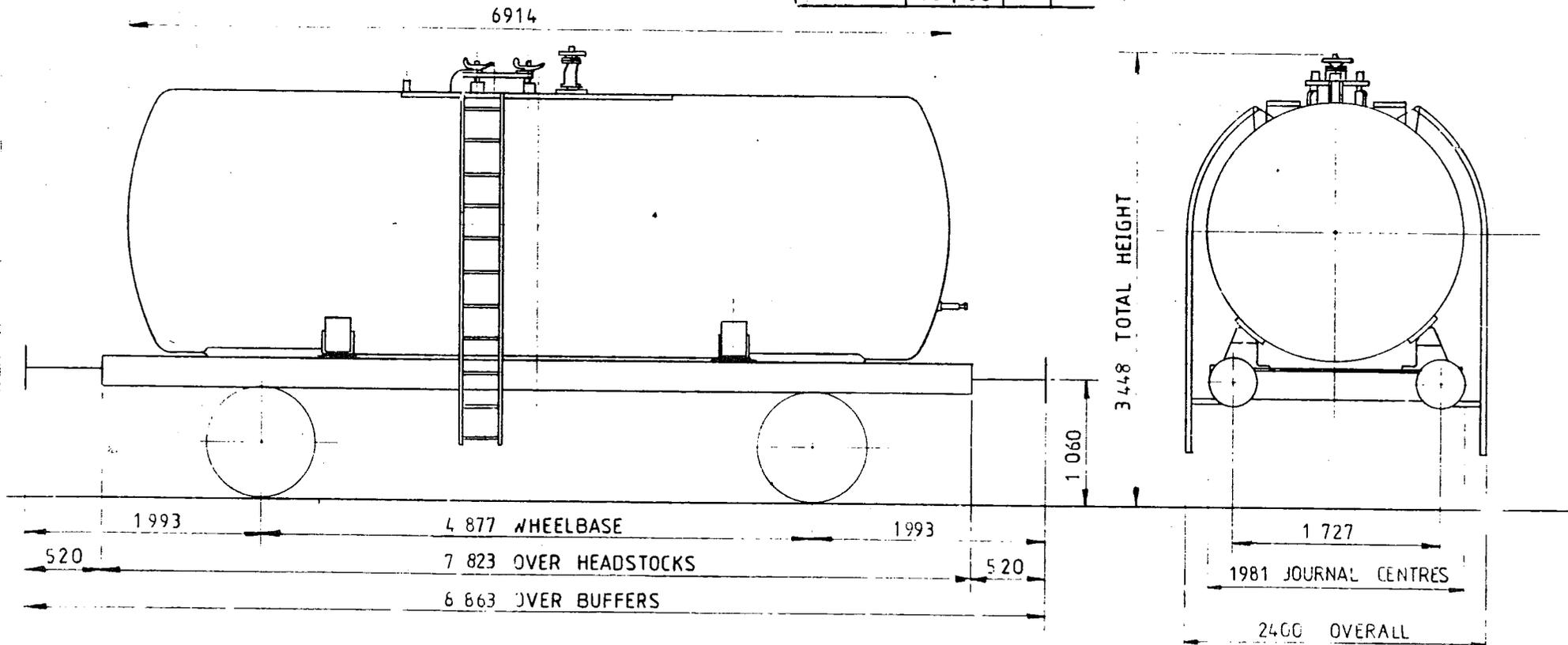

TARE	13200 kg
TARE AND CAPACITY	32800 kg
CAPACITY	21871 litres
MAX SPEED	60 mile/h
WHEELS	952 DIA.
JOURNALS	140 DIA. ROLLER BEARINGS

BUFFERS	HYDRAULIC 406 DIA. HEADS
COUPLINGS	INSTANTER
MIN CURVE	31 m
GEN ARRGT DRG No	
BRAKE	AIR BLOCK, VACUUM PIPED & HAND LEVER
SUSPENSION	DOUBLE LINK

ISSUE 1

46 tonne GLW TANK WAGON - UREA FORMALDEHYDE RESIN

TT053C

EXCESS LENGTH	4	H	M	L	E
tonnes	46	46	13	13	
VB	0	0	0	0	
AB	26	26	10	10	
RA	8	8	1	1	
MAX SPEED	60	60	60	60	

TOPS CODE		
CARKND	AARKND	OPERATION PANELS
T T B	T T B A	1 6 0 0

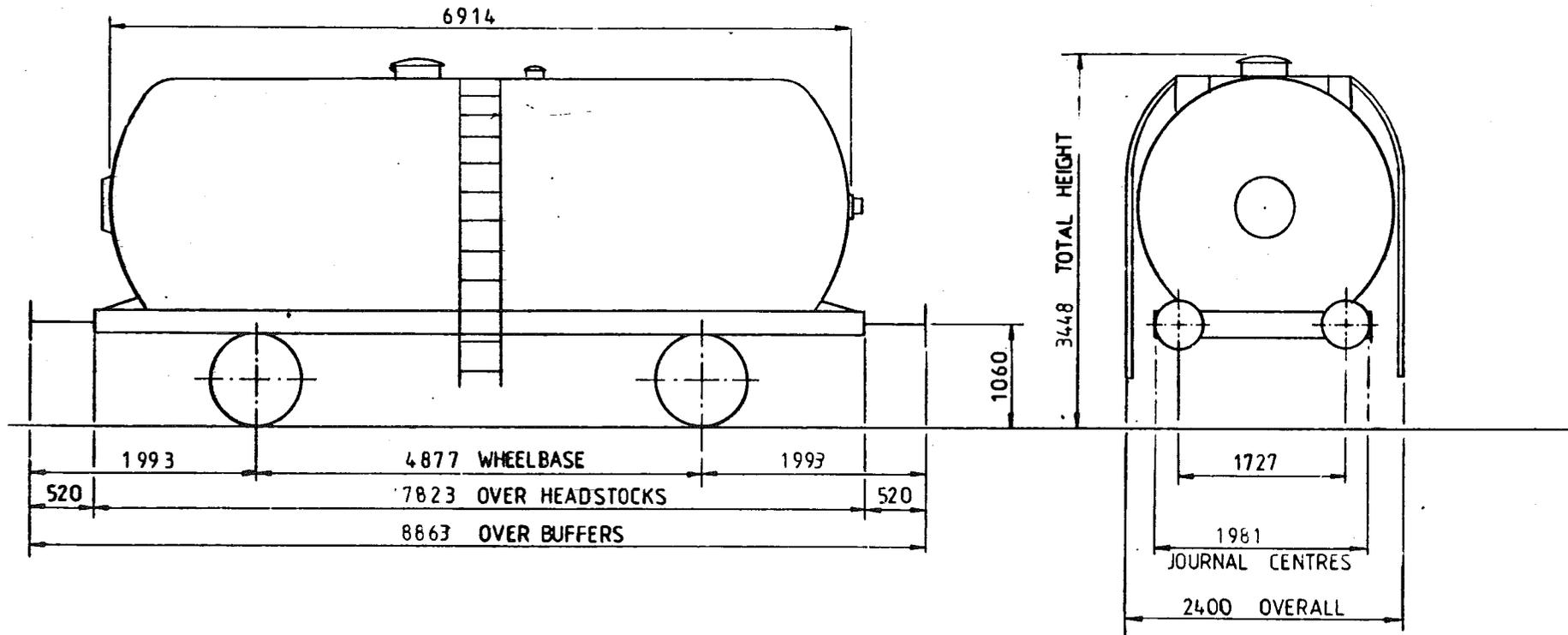

TARE	12700 kg
CARRYING CAPACITY -	33300 kg
CAPACITY -	38186 Litres
MAX SPEED	60 mile/h
WHEELS	φ 952
JOURNALS -	φ 140 ROLLER BEARINGS

BUFFERS	HYDRAULIC φ 406 HEADS
COUPLINGS	INSTANTER
MIN CURVE	31m
GEN ARRG T DRG No	
BRAKE	AIR BLOCK, VACUUM PIPED, HAND LEVER
SUSPENSION	DOUBLE LINK

ISSUE 1

EX PO. DIAGRAM 5/218(ALLOCATED)

46 tonne GLW TANK WAGON- UREA FORMALDEHYDE RESIN

TT053D

EXCESS LENGTH	H	M	L	E
4				
tonnes	46	46	13	13
VB	0	0	0	0
AB	26	26	10	10
RA	8	8	1	1
MAX SPEED	60	60	60	60

TOPS CODE										
CARKND	AARKND									
T	T	B	T	T	9	A	1	6	0	0

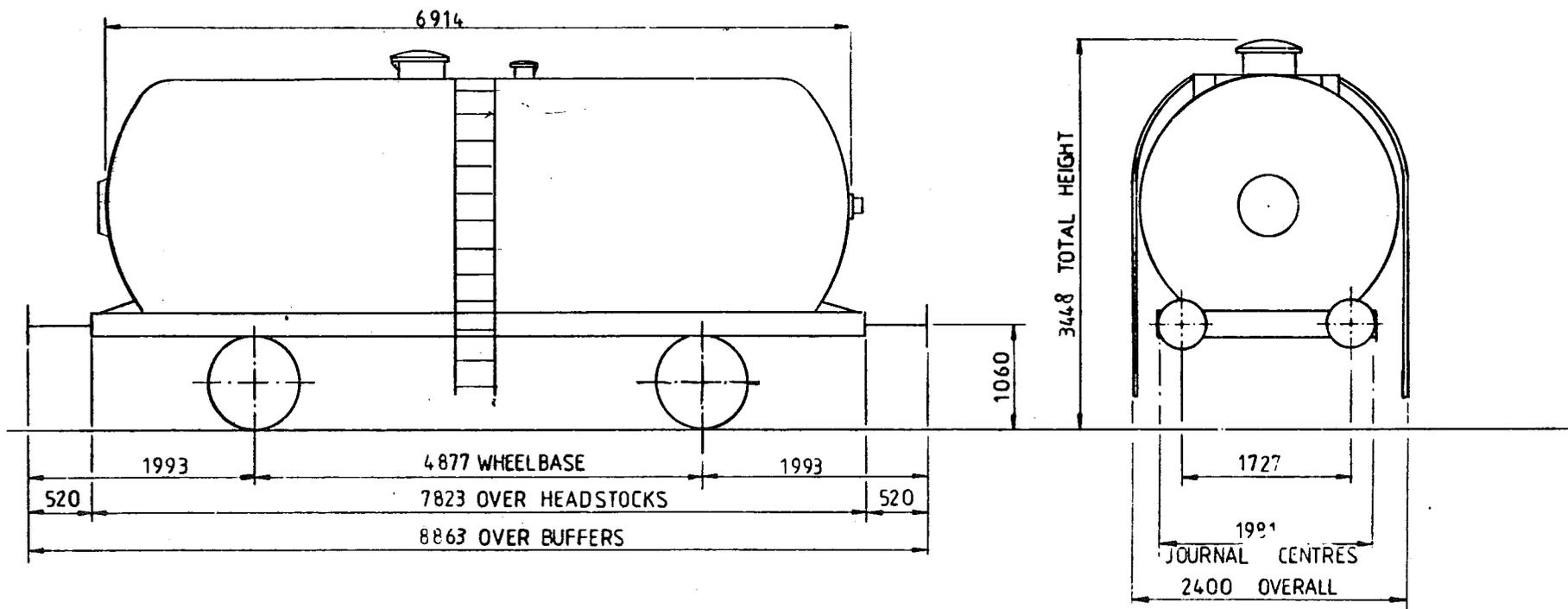

TARE	12700	kg
CARRYING CAPACITY -	33300	kg
CAPACITY -	39122	Litres
MAX SPEED	60	mile/h
WHEELS	φ 952	
JOURNALS	φ 140	ROLLER BEARINGS

BUFFERS	HYDRAULIC	φ 406	HEADS
COUPLINGS	INSTANTER		
MIN CURVE	31m		
GEN ARRGT DRG No			
BRAKE	AIR BLOCK, VACCUM PIPED, HAND LEVER		
SUSPENSION	DOUBLE LINK		

ISSUE 1

EX PO. DIAGRAM 6/218 (ALLOCATED)

46 tonne GLW TANK WAGON CAUSTIC LIQUOR

TT053E

EXCESS LENGTH	H	M	L	E
46 tonnes	46	46	13	13
VB	0	0	0	0
AB	26	26	10	10
RA	8	8	1	1
MAX SPEED	60	60	60	60

TOPS CODE			
CARKND	AARKND	FIRST PAIR	
T	T	B	T
T	B	T	B
A	1	4	8
8			

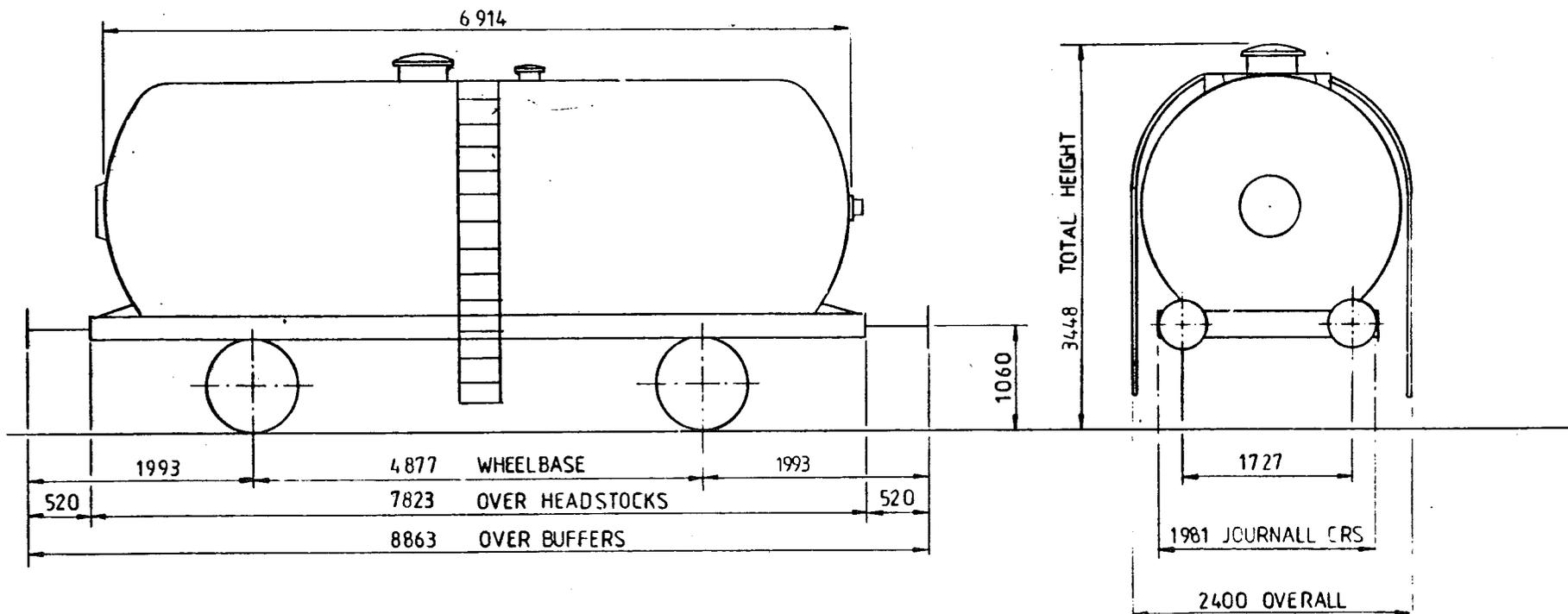

TARE	13200	kg
CARRYING CAPACITY -	32600	kg
CAPACITY -	21871	Litres
MAX SPEED	60	mile/h
WHEELS	φ 952	
JOURNALS	φ 140	ROLLER BEARINGS

BUFFERS	HYDRAULIC	φ 406	HEADS
COUPLINGS	INSTANTER		
MIN CURVE	31m		
GEN ARRG T DRG No			
BRAKE	AIR BLOCK, VACUUM PIPED, HAND LEVER		
SUSPENSION	DOUBLE LINK		

ISSUE 1

EX PO. DIAGRAM 6/21E (ALLOCATED)

46 tonne GLW TANK WAGON UREA FORMALDEHYDE RESIN

TT053G

EXCESS LENGTH	H	M	L	E
4				
tonnes	46	46	13	13
VB	0	0	0	0
AB	26	26	10	10
RA	8	8	1	1
MAX SPEED	60	60	60	60

TOPS CODE							
CARKND	AARKND	TYPICAL PARTS					
T	T	B	T	B	A	1	4 8 8

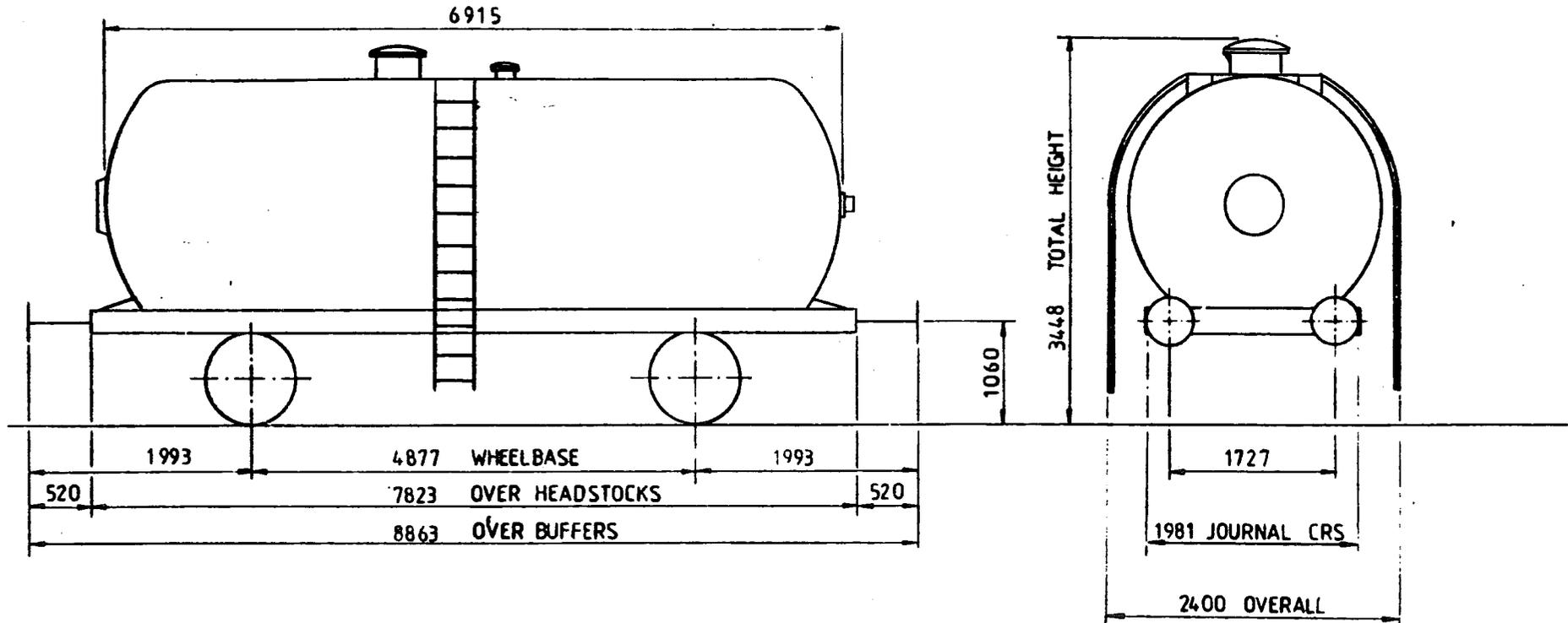

TARE	12 700	kg
CARRYING CAPACITY-	33 200	kg
CAPACITY-	21871	Litres
MAX SPEED	60	mile/h
WHEELS	φ 952	
JOURNALS-	φ 140	ROLLER BEARINGS

BUFFERS	HYDRAULIC	φ 406	HEADS
COUPLINGS	INSTANTER		
MIN CURVE	31m		
GEN ARRG T DRG No			
BRAKE	AIR BLOCK, VACUUM PIPED, HAND LEVER		
SUSPENSION	DOUBLE LINK		

ISSUE 1

EX PO. DIAGRAM 6/216 (ALLOCATED)

46 tonne GLW TANK WAGON PHOSPHORIC ACID

TT053H

EXCESS LENGTH	4	H	M	L	E
tonnes	46	46	13	13	
VB	0	0	0	0	
AB	26	26	10	10	
RA	8	8	1	1	
MAX SPEED	60	60	60	60	

TOPS CODE					
CARKND	AARKND				
T	T	B	T	B	A
1	4	8	8		

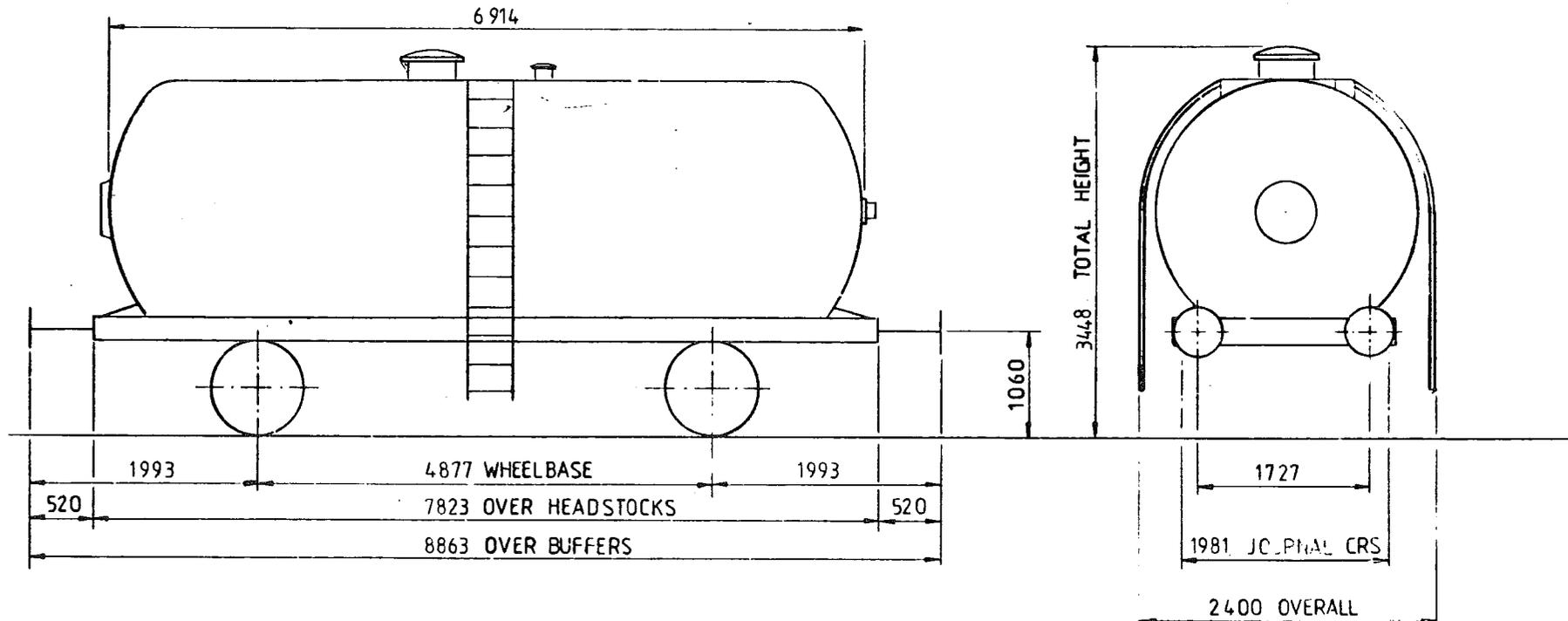

TARE	13200	kg
CARRYING CAPACITY -	32800	kg
CAPACITY -	21871	Litres
MAX SPEED	60	mile/h
WHEELS	φ 952	
JOURNALS	φ 140	ROLLER BEARINGS

BUFFERS	HYDRAULIC	φ 406	HEADS
COUPLINGS	INSTANTER		
MIN CURVE	31m		
GEN ARRG'T	DRG No		
BRAKE	AIR BLOCK, VACUUM PIPED, HAND LEVER		
SUSPENSION	DOUBLE LINK		

ISSUE 1

EX PO. DIAGRAM 6/218 (ALLOCATED)

41 tonne GLW TANK WAGON - MOLASSES

LOT NUMBER	

TOPS INFORMATION						
AARKND	OPERATING	OPERATING SPEED		BRAKE FORCE DATA		EXCESS LENGTH
CARKND	PANEL No.	60 mile/h UP TO	41 tonne GLW	10t FORCE UP TO	31 tonne GLW	RA (GLW)
TTA	A	mile/h ABOVE		26t FORCE ABOVE		4
						7
						DESIGN SHEET
						W1096

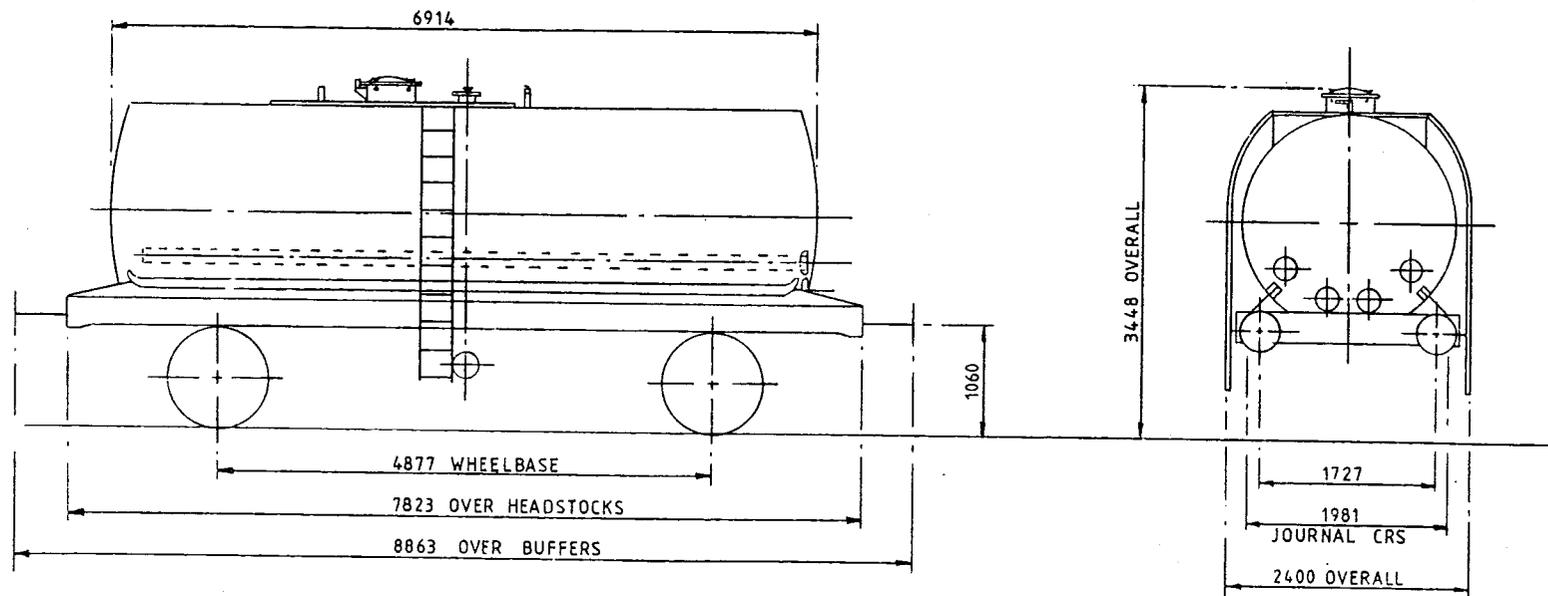

TARE-	12,800 Kg
CAPACITY, WEIGHT-	28,200 Kg
CAPACITY, VOLUME-	21,871 litres
MIN. CURVE-	31m
GEN. ARRGT. DRG. NO.-	

BRAKE-	AIR BLOCK & HAND LEVER
SUSPENSION-	DOUBLE LINK
COUPLINGS-	INSTANTER
BUFFERS-	HYDRAULIC 406 DIA HEADS
WHEELS-	952 DIA
JOURNALS-	140 DIA ROLLER BEARINGS

ISSUE 1

41 tonne GLW TANK WAGON - MOLASSES

LOT NUMBER	

TOPS INFORMATION									
AARKND	OPERATING		OPERATING SPEED		BRAKE FORCE DATA		EXCESS LENGTH	RA (GLW)	DESIGN SHEET
CARKND	PANEL No.		60 mile/h UP TO	41 tonne GLW	10t FORCE UP TO	31 tonne GLW	4	7	W1098
T T A A			mile/h ABOVE		26t FORCE ABOVE				

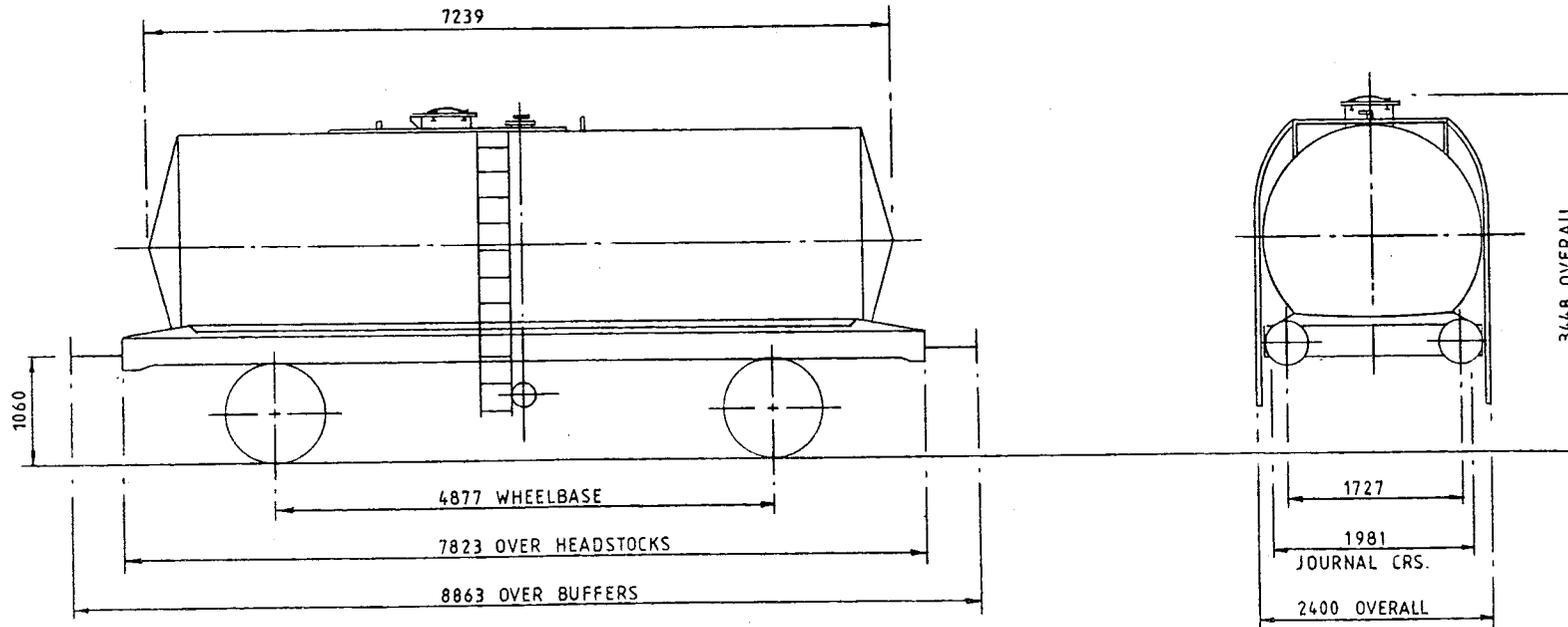

TARE-	13,150 Kg
CAPACITY, WEIGHT-	27,850 Kg
CAPACITY, VOLUME-	21,871 litres
MIN. CURVE-	31 m
GEN. ARRGT. DRG. NO.-	

BRAKE-	AIR BLOCK & HAND LEVER
SUSPENSION-	DOUBLE LINK
COUPLINGS-	INSTANTER
BUFFERS-	HYDRAULIC 406 DIA HEADS
WHEELS-	952 DIA
JOURNALS-	140 DIA ROLLER BEARINGS

ISSUE 1

46 tonnes G.L.W. TANK WAGON – CYCLOHEXANE

TTO54A

EXCESS LENGTH	7	H	M	L	E
tonnes	46	46	16	16	
VB	0	0	0	0	
AB	24	24	11	11	
RA	8	8	1	1	
MAX. SPEED	60	60	60	60	

TOPS CODE		
CARKND	AARKND	OPERATING PANEL
T	T	B T T B A 1 5 6 6

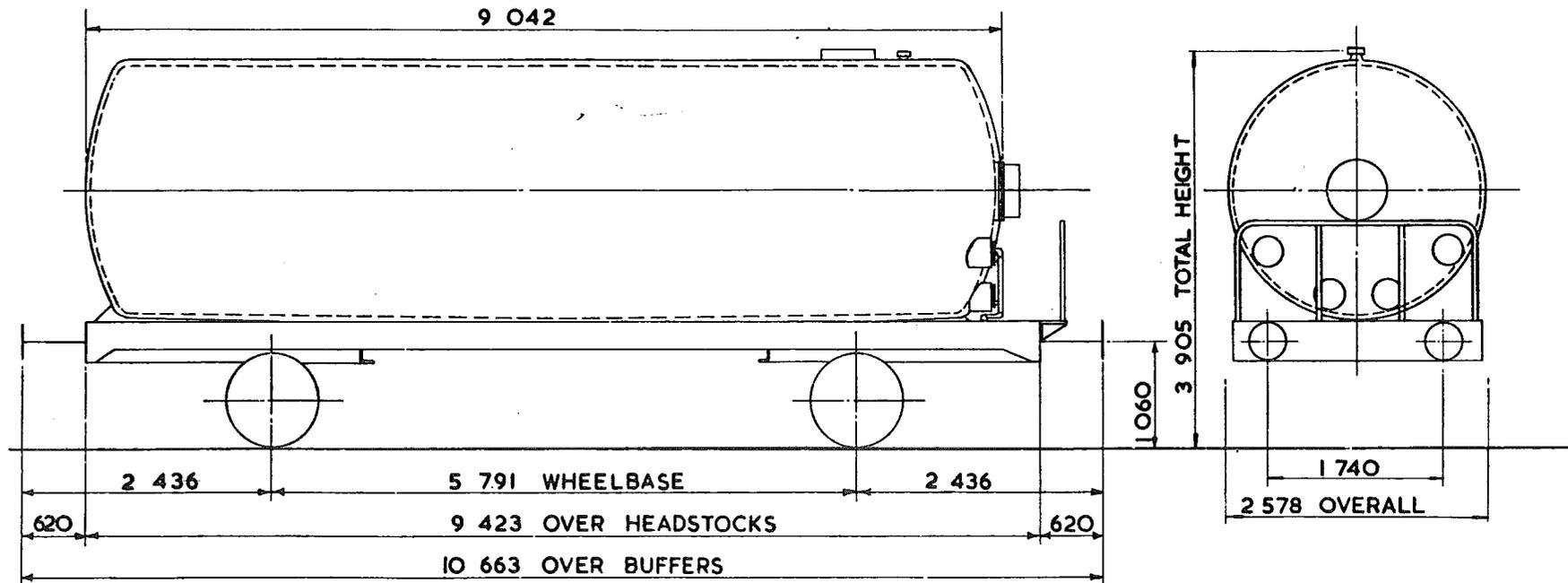

TARE - 15 750 kg.
CARRYING CAPACITY - 30 000 kg.
CAPACITY - 40 287 litres
MAX. SPEED - 60 mile/h
WHEELS - 952 DIA.
JOURNALS - 140 DIA. ROLLER BEARINGS

BUFFERS SELF CONTAINED 400 DIA. HEADS
COUPLINGS - INTERNATIONAL SCREW
MIN. CURVE - 36m
GEN. ARRGT. DRG. No -
BRAKE - AIR BLOCK, VACUUM PIPE & HAND LEVER.
SUSPENSION - DOUBLE LINK

BUILDER - CHARLES ROBERTS
OWNER - TIGER RAILCAR LEASING.
REGISTERED BY - C.M. & E.E. (B.R.B.) DERBY.
YEAR BUILT - 1969/71
REGISTRATION Nos. - 51895 TO 51947
OWNERS Nos. - 895 TO 947

ISSUE 2
EX. P.O. DIAGRAM 6/187

46 tonnes G.L.W. TANK WAGON - CO₂

TTO55A

EXCESS LENGTH	5	H	M	L	E
tonnes	46	46	18	18	
VB	0	0	0	0	
AB	24	24	12	12	
RA	3	8	1	1	
MAX SPEED	60	60	60	60	

TOPS CODE				
CARKND	AARKND	OPERATING PANEL No		
T	T	B	T	T
		B	A	1
				2
				4
				5

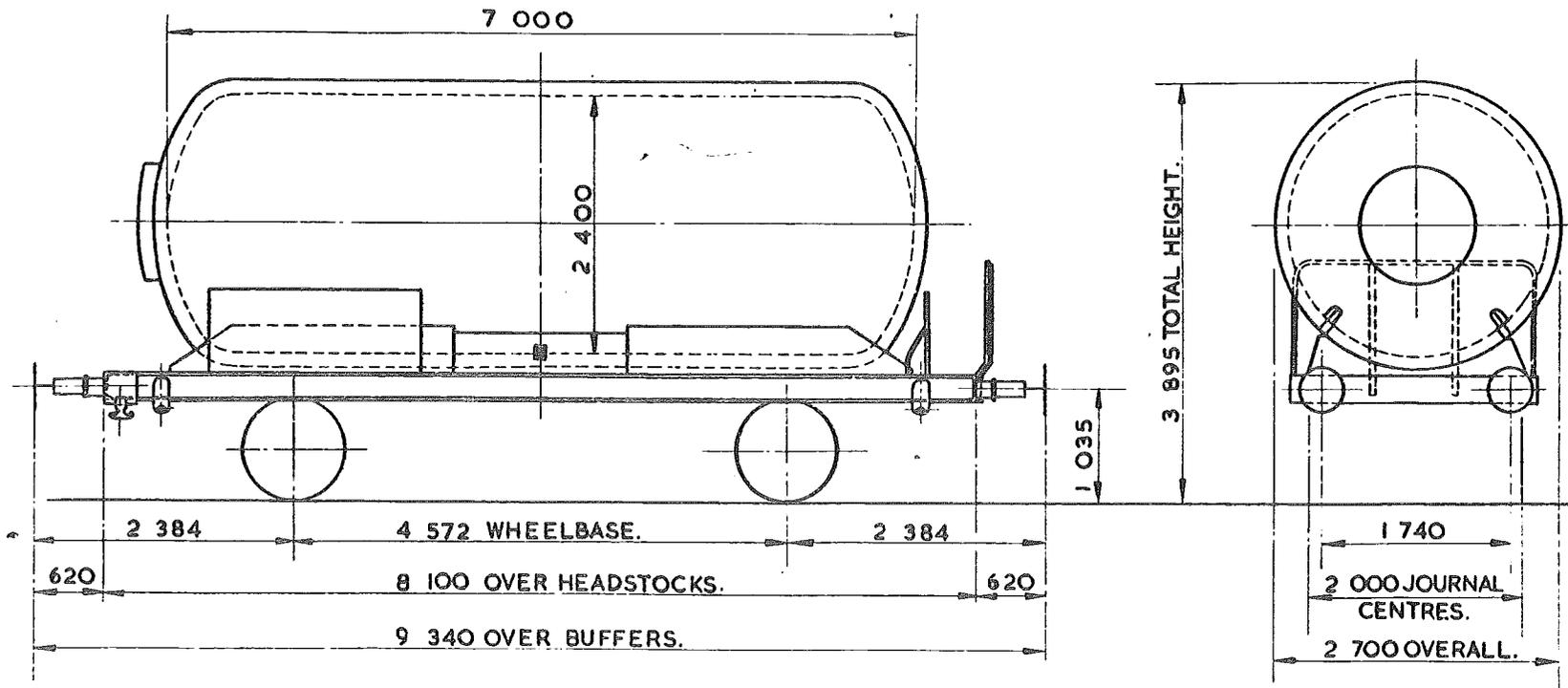

TARE -	17550 kg
CARRYING CAPACITY -	28 400 kg
CAPACITY -	29 094 litres
MAX. SPEED -	60 mile/h
WHEELS -	1000 DIA.
JOURNALS -	140 DIA. ROLLER BEARINGS.

BUFFERS -	HYDRAULIC 406 DIA. HEADS
COUPLINGS -	INTERNATIONAL SCREW.
MIN. CURVE -	31 m
GEN. ARRGT. DRG. No. -	
BRAKE -	AIR BLOCK, VACUUM PIPED & HAND LEVER
SUSPENSION -	GLOUCESTER PEDESTAL.

BUILDER -	FAUVET - GIREL FRANCE
OWNER -	STORAGE & TRANSPORT SYSTEMS.
REGISTERED BY -	C.M. & E.E. (B.R.B.) DERBY
YEAR BUILT -	1970.
REGISTRATION Nos. -	53219 TO 53235.
OWNERS Nos. -	2026 TO 2035.

ISSUE 2
EX. P.O. DIAGRAM 6/211.

46 tonne G.L.W. CO₂ TANK WAGON

TT055C

EXCESS LENGTH	H	M	L	E
tonnes	46	46	18	18
VB	0	0	0	0
AB	25	25	13	13
RA	8	8	1	1
MAX SPEED	60	60	60	60

TOPS CODE										
CARKND		AARKND			OPERATING PANEL No					
T	T	B	T	T	B	A	1	0	7	8

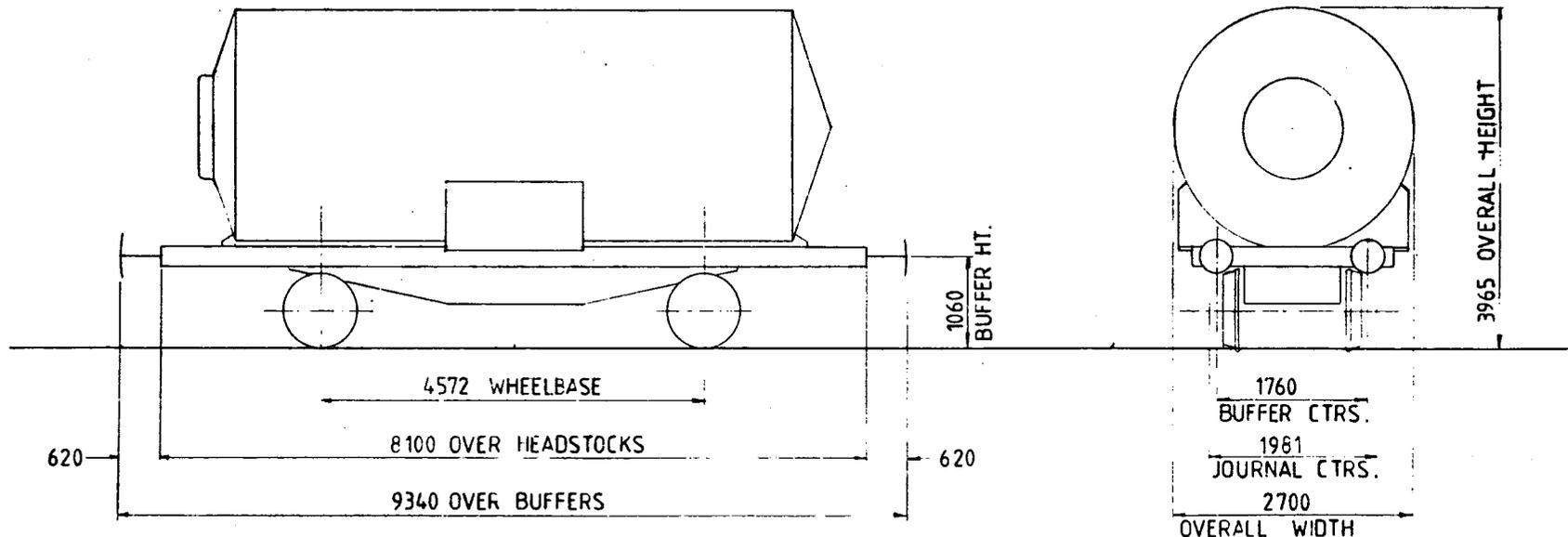

TARE -	17 800 kg.
CARRYING CAPACITY -	28 200 kg
CAPACITY -	29 000 litres
MAX. SPEED -	60 m.p.h.
WHEELS -	952 DIA.
JOURNALS -	140 DIA. ROLLER BEARINGS

BUFFERS - HYDRAULIC 406 DIA HEADS
COUPLINGS - INTERNATIONAL SCREW
MIN. CURVE - 31m SINGLY 35m CLOSE COUPLED
GEN. ARRGT. DRG No. - FAUVET-GIREL 113390
BRAKE - AIR BLOCK HAND SCREW & LEVER
SUSPENSION - GLOUCESTER PEDESTAL

ISSUE 1

EX PRIVATE OWNER DIAGRAM No 6/213

46tonne GLW TANK WAGON

LOT NUMBER	

TOPS INFORMATION										
AARKND	OPERATING		OPERATING SPEED			BRAKE FORCE DATA		EXCESS LENGTH	RA (GLW)	DESIGN SHEET
CARKND	PANEL No.		60 mile/h UP TO 46 tonne GLW			12t FORCE UP TO 31tonne GLW		5	8	W1342
T T A A			mile/h ABOVE			24t FORCE ABOVE				

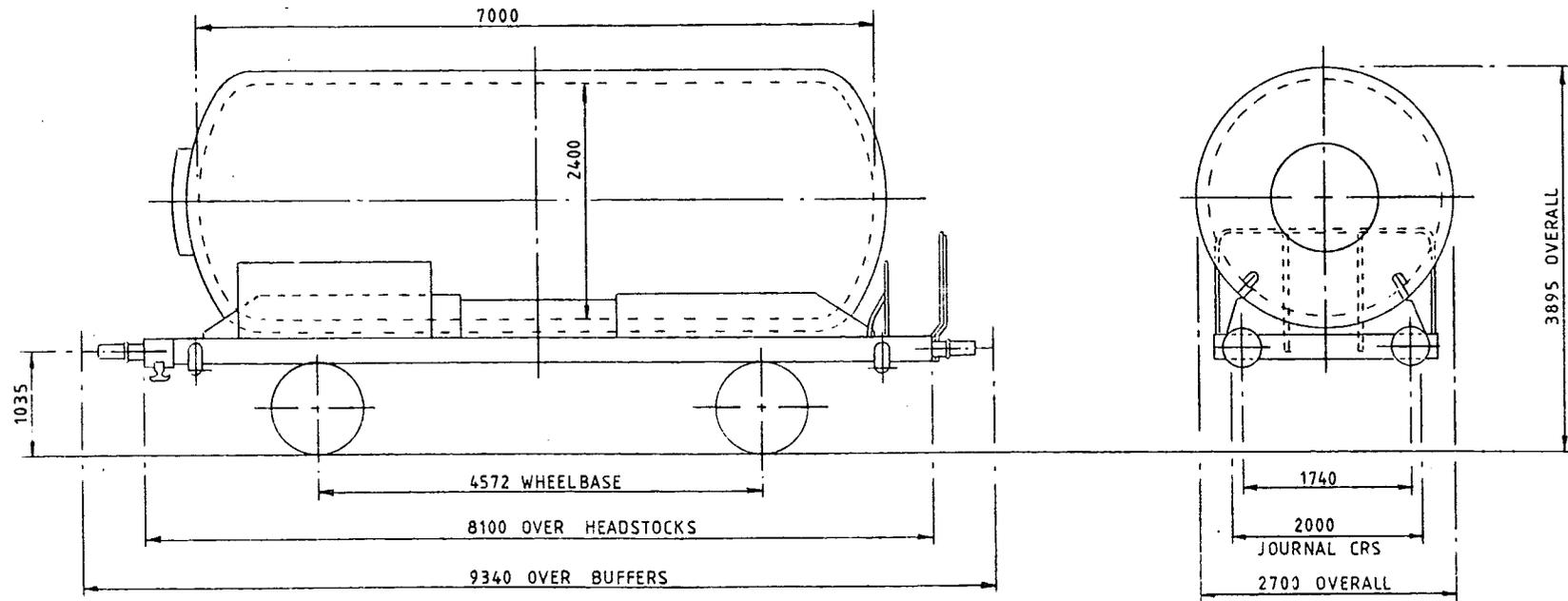

TARE-	17.550 Kg
CAPACITY, WEIGHT-	28.400 Kg
CAPACITY, VOLUME-	29.094 litres
MIN. CURVE-	31 m
GEN. ARRGT. DRG. NO.-	

BRAKE-	AIR BLOCK & HAND LEVER
SUSPENSION-	GLOUCESTER PEDESTAL
COUPLINGS-	INTERNATIONAL SCREW
BUFFERS-	HYDRAULIC 406 DIA HEADS
WHEELS-	1000 DIA
JOURNALS-	140 DIA ROLLER BEARINGS

ISSUE 1

46 tonne GLW TANK WAGON

LOT NUMBER	

TOPS INFORMATION												
AARKND		OPERATING			OPERATING SPEED		BRAKE FORCE DATA			EXCESS LENGTH	RA (GLW)	DESIGN SHEET
CARKND		PANEL No.			60 mile/h UP TO		13t FORCE UP TO			5	8	W1341
T T A A					mile/h ABOVE 46 tonne GLW		25t FORCE ABOVE 31 tonne GLW					

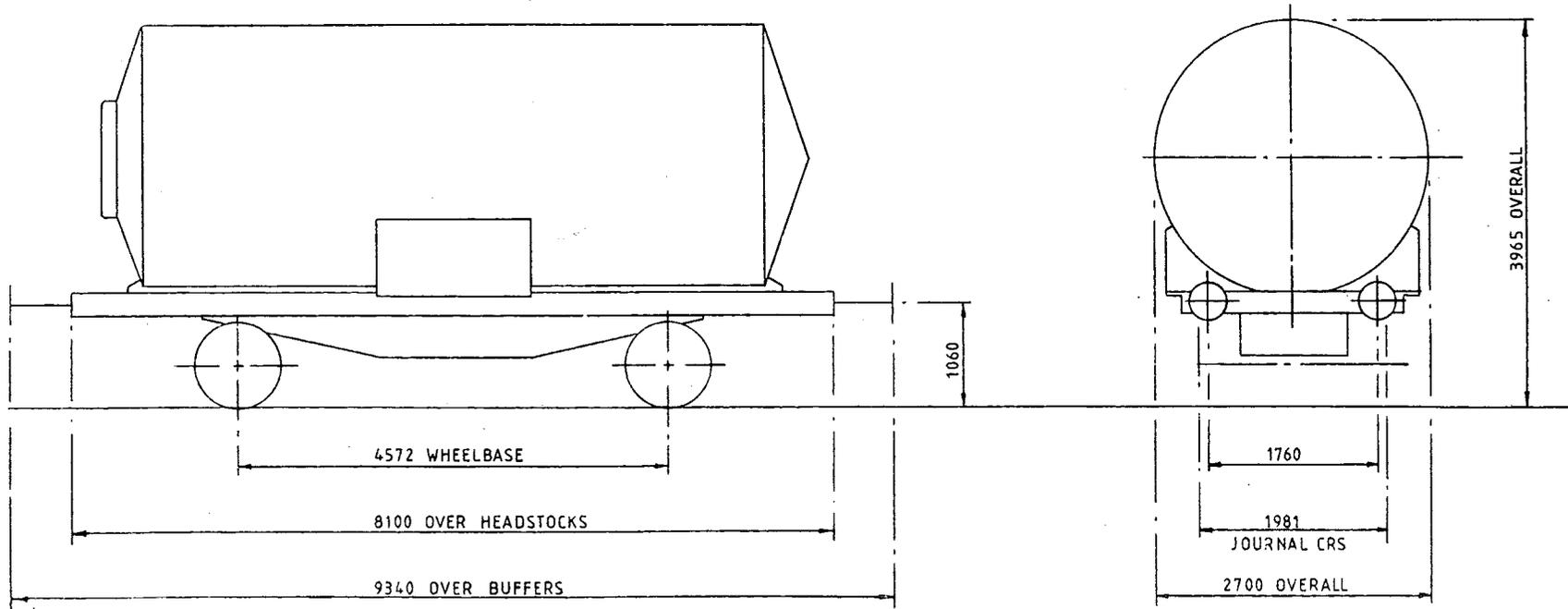

TARE-	17.800 Kg
CAPACITY, WEIGHT-	28.200 Kg
CAPACITY, VOLUME-	29.000 litres
MIN. CURVE-	31m SINGLY, 35m CLOSE COUPLED
GEN. ARRGT. DRG. NO.	FAUVET-GIREL 113390

BRAKE-	AIR BLOCK & HAND LEVER
SUSPENSION-	GLOUCESTER PEDESTAL
COUPLINGS-	INTERNATIONAL SCREW
BUFFERS-	HYDRAULIC 406 DIA HEADS
WHEELS-	952 DIA
JOURNALS-	140 DIA ROLLER BEARINGS

ISSUE 1

46 tonnes G.L.W TANK WAGON CLASS B LAGGED & COILED.

TTO56A

EXCESS LENGTH	4	H	M	L	E
tonnes	46	46	15	15	
VB	0	0	0	0	
AB	19	19	8	8	
RA	8	8	1	1	
MAX. SPEED	60	60	60	60	

TOPS CODE		
CARKND	AARKND	OPERATING PANEL No
T	T	B
T	B	T
B	A	I
A	I	4
I	4	8
4	8	9

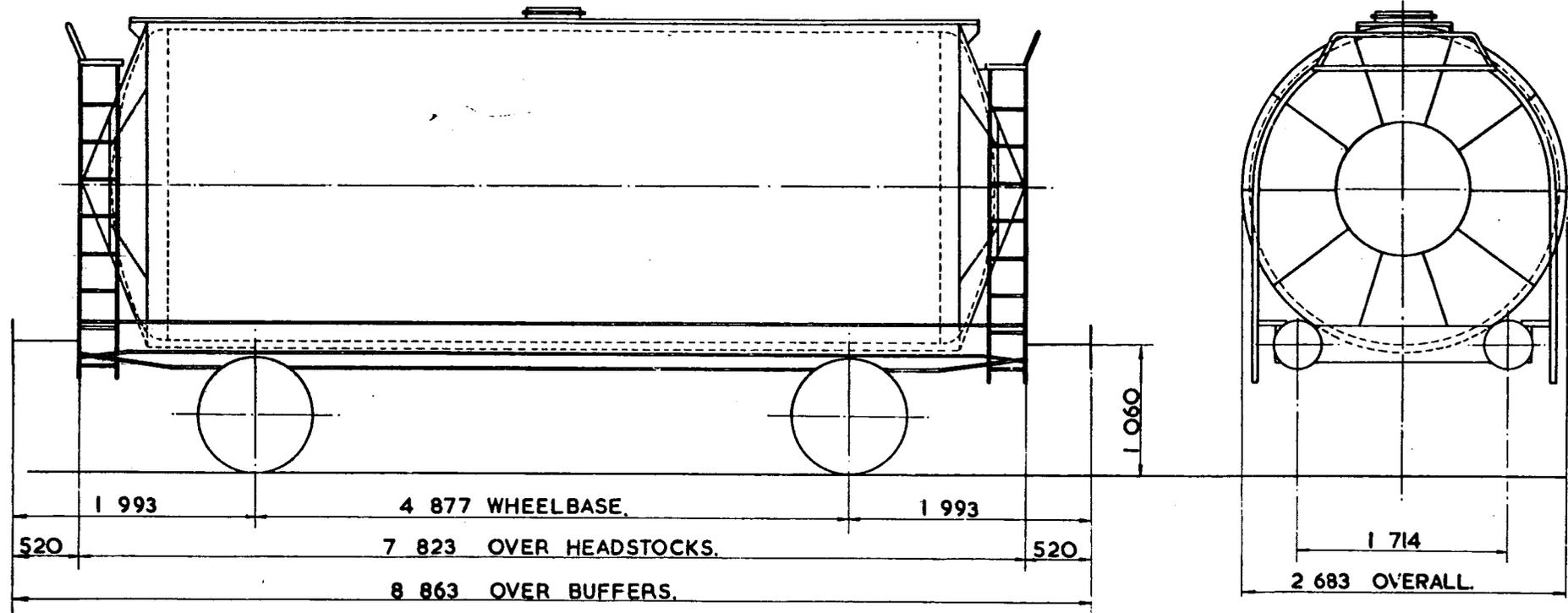

TARE - 13400kg.
CARRYING CAPACITY - 32600kg
CUBIC CAPACITY - 35600 litres.
MAX. SPEED - 60 mile/h
WHEELS - 952 DIA.
JOURNALS - 140 DIA. ROLLER BEARINGS.

BUFFERS - HYDRAULIC 406 DIA. HEADS.
COUPLINGS - INSTANTER.
MIN. CURVE - 31m.
GEN. ARRGT. DRG. No. -
BRAKE - AIR BLOCK, VACUUM PIPED & HAND LEVER.
SUSPENSION - DOUBLE LINK.

BUILDER - STANDARD RAILWAY WAGON CO. LTD.
OWNER - PROCOR (UK) LTD.
REGISTERED BY - CM. & E.E. (B.R.B.) DERBY.
YEAR BUILT - 1968
REGISTRATION Nos. - 58061 TO 58078.
OWNERS Nos. - 61 TO 78.

ISSUE 2

EX.P.O. DIAGRAM 6/689 (ALLOCATED)

46 tonnes G.L.W. TANK WAGON - BITUMEN

TTO57A

EXCESS LENGTH	5	H	M	L	E
tonnes	46	46	17	17	
VB	0	0	0	0	
AB	23	23	14	14	
RA	8	8	1	1	
MAX. SPEED	60	60	45	45	

TOPS CODE									
CARKND		AARKND			OPERATING PANEL No.				
T	T	B	T	B	A	1	5	3	9

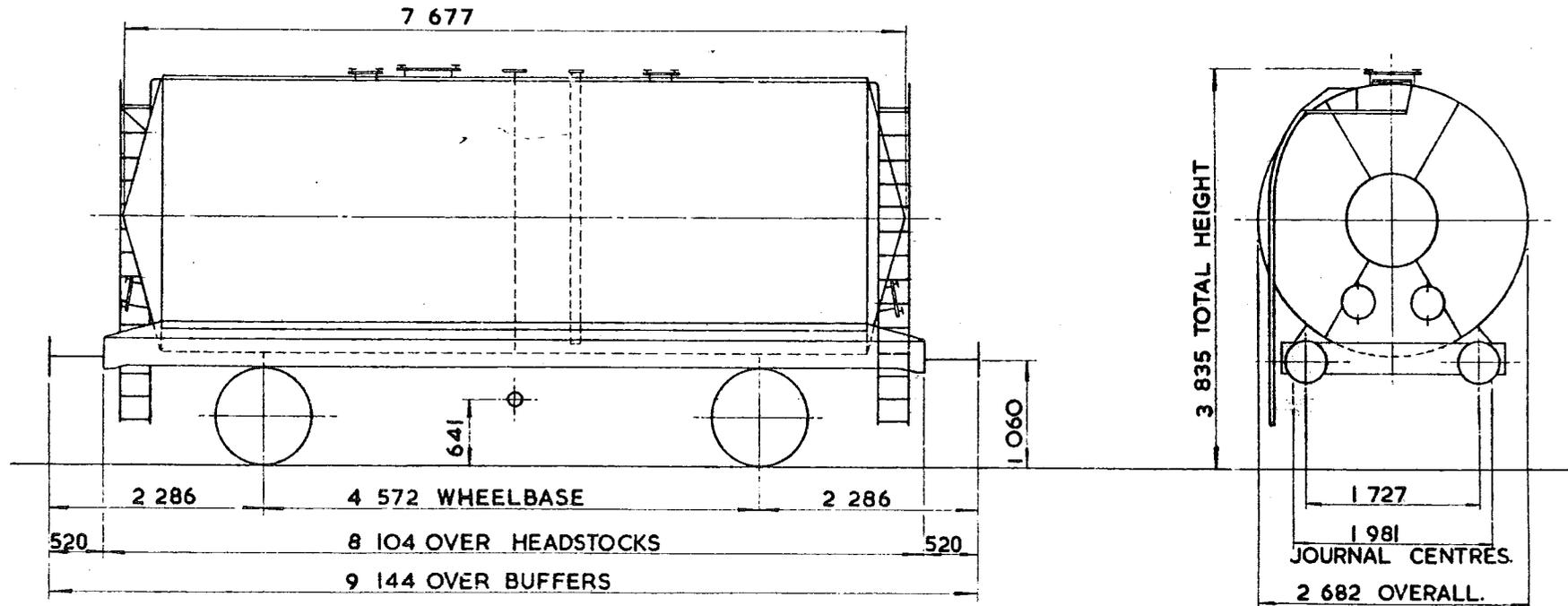

TARE - 16 750 kg.
CARRYING CAPACITY - 29 200 kg.
CAPACITY - 33 004 litres.
MAX. SPEED - 60 mile/h.
WHEELS - 952 DIA.
JOURNALS - 140 DIA. ROLLER BEARINGS

BUFFERS - HYDRAULIC 406 DIA. HEADS
COUPLINGS - INSTANTER
MIN. CURVE - 31m.
GEN. ARRGT. DRG. No. -
BRAKE - AIR BLOCK, VACUUM PIPED & HAND LEVER.
SUSPENSION - DOUBLE LINK

BUILDER - STANDARD RAILWAY WAGON CO.
OWNER - PROCOR (U.K.) LTD.
REGISTERED BY - C.M.&E.E. (B.R.B.) DERBY.
YEAR BUILT - 1970
REGISTRATION Nos. - 58001 TO 58025
OWNERS Nos. - 9001 TO 9025

ISSUE 2
EX P.O. DIAGRAM 6/206

46 tonnes G.L.W. TANK WAGON - BITUMEN

TTO57B

EXCESS LENGTH	5	H	M	L	E
tonnes	46	46	17	17	
VB	0	0	0	0	
AB	23	23	14	14	
RA	8	8	1	1	
MAX. SPEED	60	60	45	45	

TOPS CODE										
CARKND	AARKND			OPERATING PANEL NO.						
T	T	B	T	T	B	A	1	5	3	9

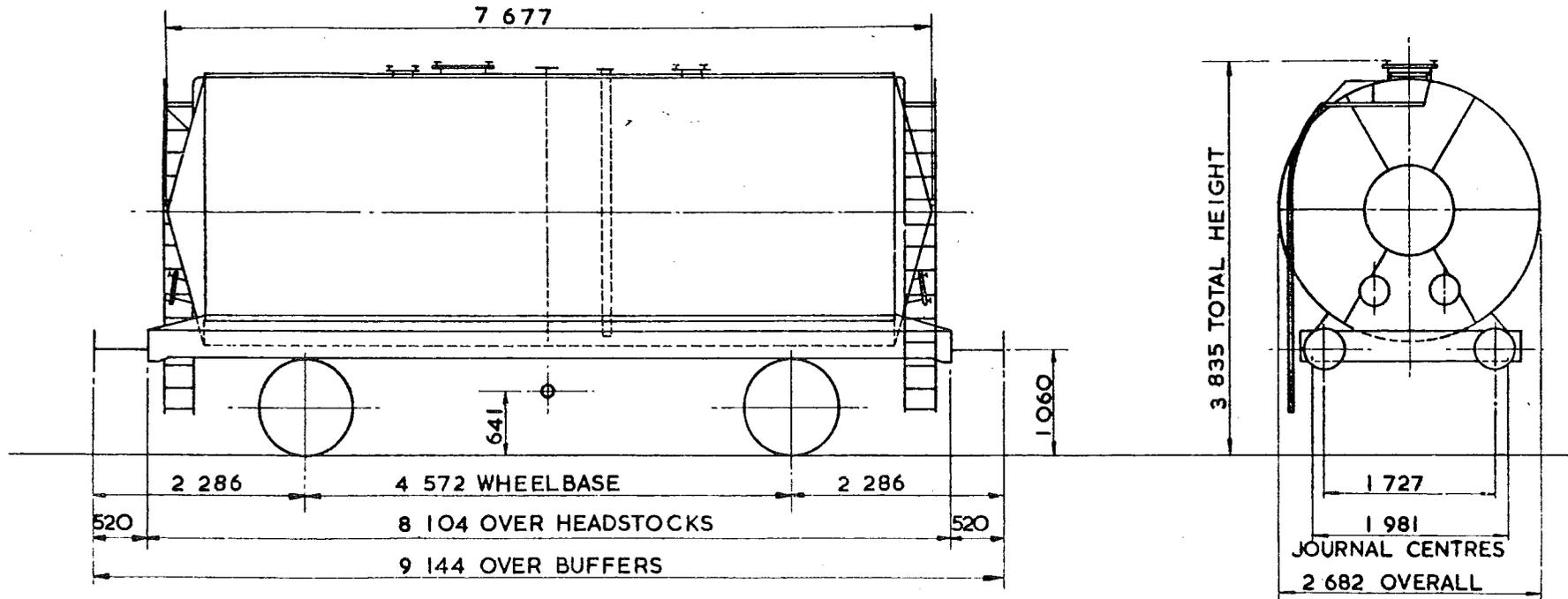

TARE - 16750 kg.
CARRYING CAPACITY - 29200 kg.
CAPACITY - 33004 litres.
MAX. SPEED - 60 mile/h.
WHEELS - 952 DIA.
JOURNALS - 140 DIA. ROLLER BEARINGS

BUFFERS - HYDRAULIC 406 DIA. HEADS
COUPLINGS - INSTANTER
MIN. CURVE - 31m
GEN. ARRGT. DRG. No. -
BRAKE - AIR BLOCK, VACUUM PIPED & HAND LEVER.
SUSPENSION - DOUBLE LINK

BUILDER - STANDARD RAILWAY WAGON Co.
OWNER - PROCOR (U.K.) LTD.
REGISTERED BY - C.M. & E.E. (B.R.B.) DERBY
YEAR BUILT - 1971
REGISTRATION Nos. - 58941 TO 58946
OWNERS Nos. - 1. TO 6.

ISSUE 2
EX. P.O. DIAGRAM 6/212

46 tonnes G.L.W. TANK WAGON - BITUMEN

TTO58A

EXCESS LENGTH	4	H	M	L	E
tonnes	46	46	17	17	
VB	0	0	0	0	
AB	22	22	9	9	
RA	8	8	1	1	
MAX SPEED	60	60	45	45	

TOPS CODE		
CARKND	AARKND	RESIDUAL
T	T	B
T	T	B
A	I	S
B	I	

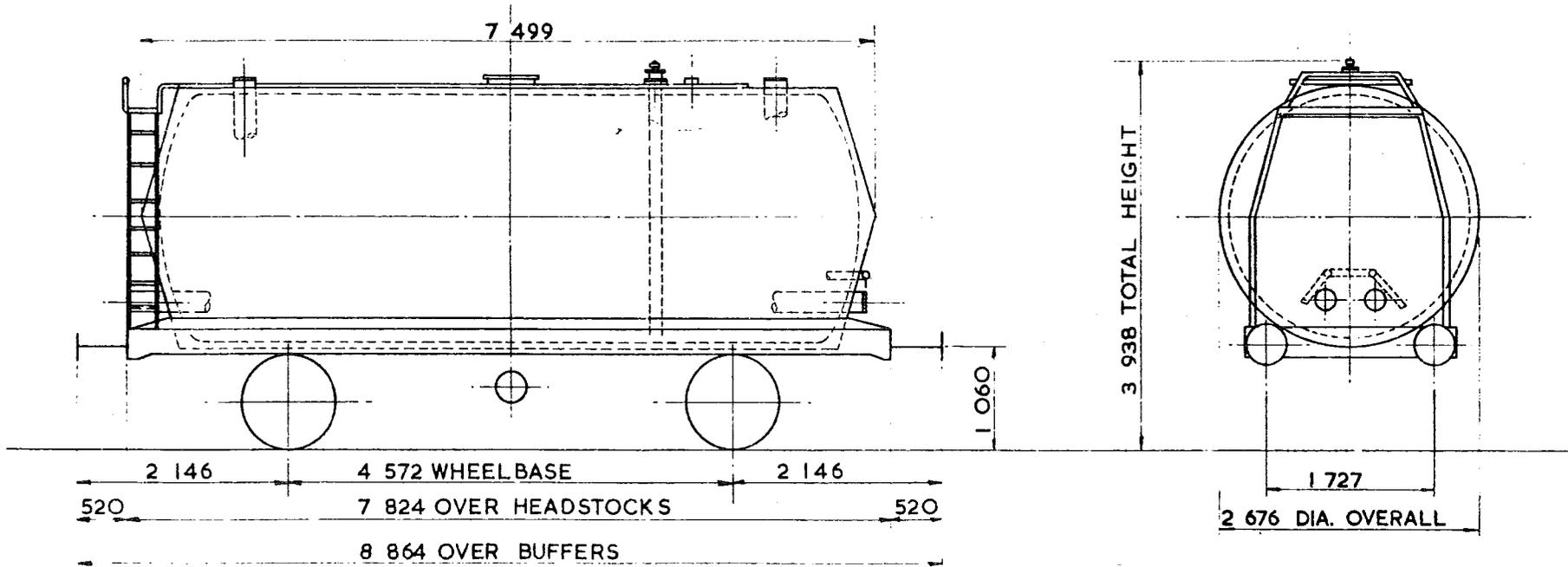

TARE 16 500kg
CARRYING CAPACITY - 29 500kg
CAPACITY - 31 866 litres
MAX SPEED 60 mile/h
WHEELS 952 DIA.
JOURNALS 140 DIA. ROLLER BEARINGS

BUFFERS - HYDRAULIC 406 DIA. HEADS
COUPLINGS - INSTANTER
MIN. CURVE - 31m
GEN. ARRGT DRG. No. -
BRAKE - AIR BLOCK, VACUUM PIPED & HAND LEVER
SUSPENSION - DOUBLE LINK

BUILDER - CHARLES ROBERTS
OWNER - SUKO
REGISTERED BY - C.M. & EE. (B.R.B.) DERBY
YEAR BUILT - 1969
REGISTRATION Nos 61908 TO 61954
OWNERS Nos. -

ISSUE 2
EX. P.O. DIAGRAM 6/205

46 tonnes G.L.W. TANK WAGON-CLASS B-LAGGED & COILED

TTO58B

EXCESS LENGTH	4	H	M	L	E
tonnes	46	46	14	14	
VB					
AB	22	22	9	9	
RA	8	8	1	1	
MAX SPEED	60	60	45	45	

TOPS CODE										
CARKND			AARKND			OPERATING PANEL N				
T	T	A	T	T	A	A	I	S	4	O

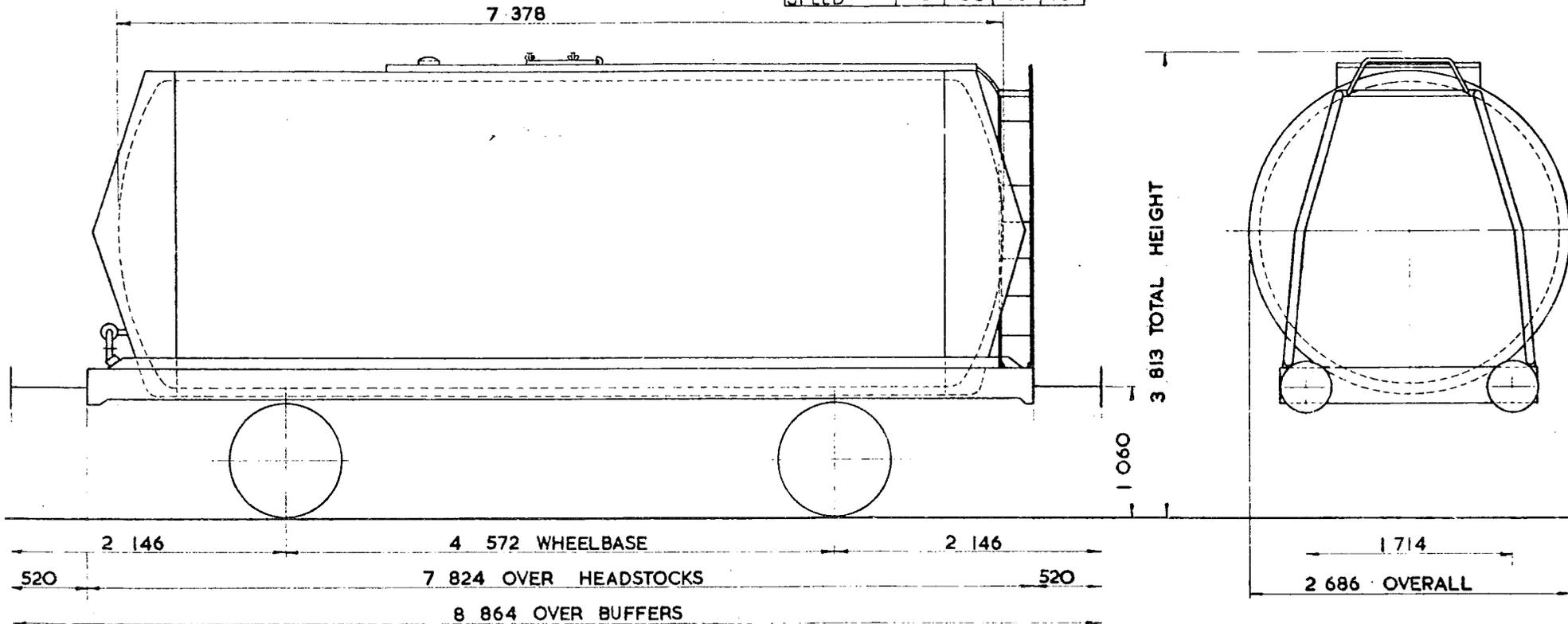

TARE - 14 100 kg.
CARRYING CAPACITY - 31 900 kg.
CAPACITY - 36 118 litres.
MAX. SPEED - 60 mile/h.
WHEELS - 952 DIA.
JOURNALS - 140 DIA. ROLLER BEARINGS

BUFFERS - HYDRAULIC 406 DIA. HEADS
COUPLINGS - INSTANTER
MIN. CURVE - 31m.
GEN. ARRGT. DRG. No. -
BRAKE - AIR BLOCK & HAND LEVER.
SUSPENSION - DOUBLE LINK

BUILDER - R.Y. PICKERING
OWNER - SUKO & BPO
REGISTERED BY - C.M. & E.E. (B.R.B.) DERBY.
YEAR BUILT - 1969
REGISTRATION Nos. - SUKO 63100 TO 63159 (RANGE) BPO 63160 TO 63199 (RANGE)
OWNERS Nos. -

ISSUE 2
EX P.O. DIAGRAM 6/189

46 tonnes G.L.W. TANK WAGON CLASS A

TT 058C

EXCESS LENGTH	4	H	M	L	E
tonnes	46	46	14	14	
VB	0	0	0	0	
AB	22	22	9	9	
HA	8	8	1	1	
MAX SPEED	60	60	45	45	

TOPS CODE										
CARKND		AARKND			OPERATION PANELS					
T	T	A	T	T	A	A	1	4	7	4

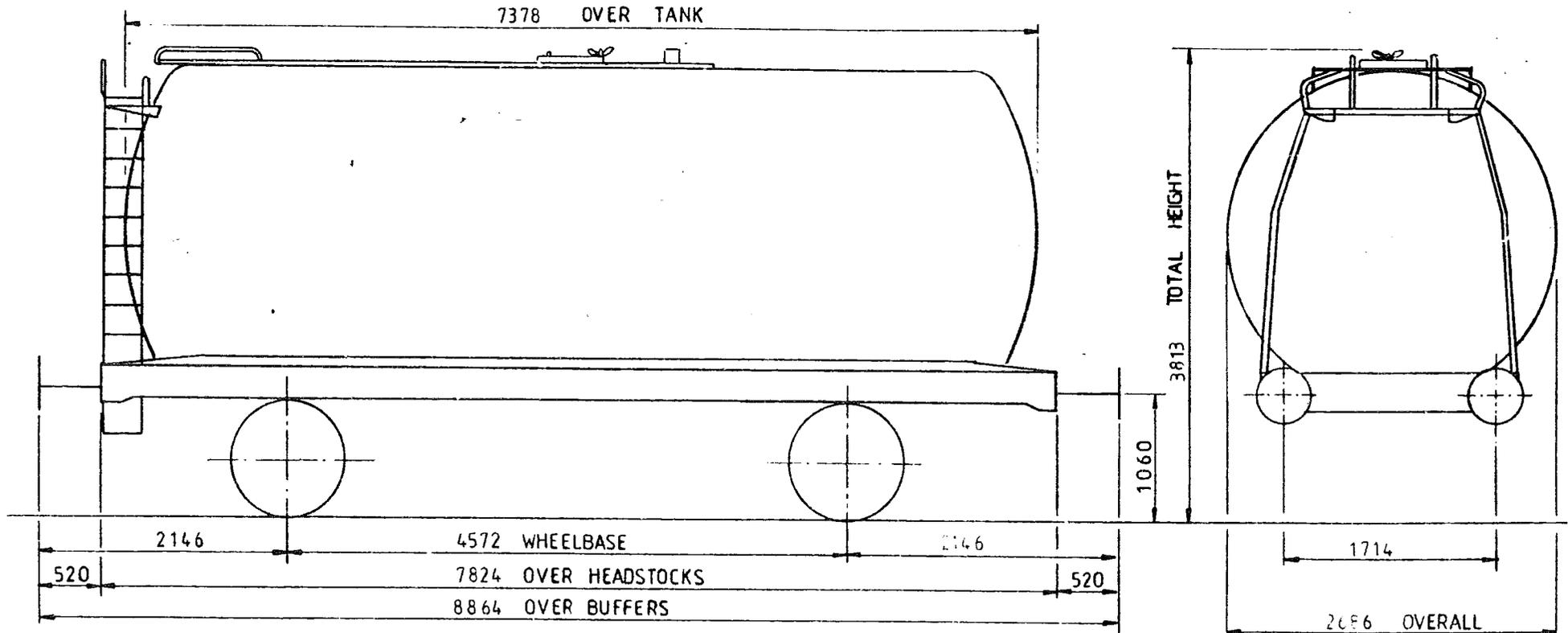

TARE	14100 kg
CARRYING CAPACITY	31900 kg
CAPACITY	36118 Litres
MAX SPEED	60 mile/h
WHEELS	φ 952
JOURNALS	φ140 ROLLER BEARINGS

BUFFERS	HYDRAULIC φ406 HEADS
COUPLINGS	INSTANTER
MIN CURVE	31 m
GEN ARRGT DRG No	
BRAKE	AIR BLOCK HAND LEVER
SUSPENSION	DOUBLE LINK

ISSUE 1

EX PO DIAGRAM 6/89 (ALLOCATED)

46 tonnes G.L.W. TANK WAGON CLASS A

TT058D

EXCESS LENGTH	4	H	M	L	E
tonnes	46	46	14	14	
VB					
AB	22	22	9	9	
RA	8	8	1	1	
MAX SPEED	60	60	60	60	

TOPS CODE									
CARKND	AARKND	STRAIGHT WAGON							
T	T	A	T	A	A	1	5	8	8

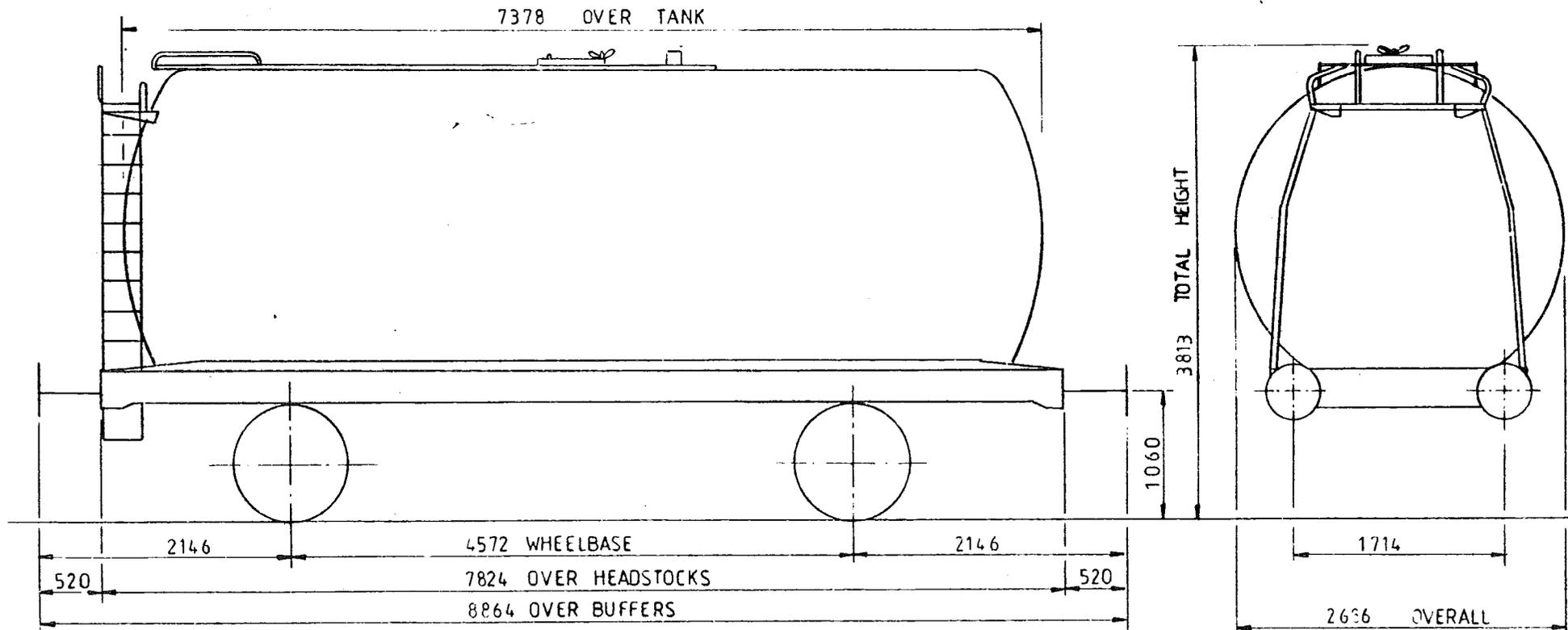

TARE	14 100 kg
CARRYING CAPACITY	31900 kg
CAPACITY	36118 Litres
MAX SPEED	60 mile/h
WHEELS	φ 952
JOURNALS	φ140 ROLLER BEARINGS

BUFFERS	HYDRAULIC φ406 HEADS
COUPLINGS	INSTANTER
MIN CURVE	31 m
GEN ARRGT DRG No	
BRAKE	AIR BLOCK HAND LEVER
SUSPENSION	UIC DOUBLE LINK, PARABOLIC SPRINGS

ISSUE 1

EX PO DIAGRAM 6/189 (ALLOCATED)

46 tonnes G.L.W. TANK WAGON BITUMEN

TT 058E

EXCESS LENGTH	4	H	M	L	E
tonnes	46	46	14	14	
VB					
AB	22	22	9	9	
RA	8	8	1	1	
MAX SPEED	60	60	60	60	

TOPS CODE							
CARKND	AARKND			FIRST & SECOND PARTS			
T	T	A	T	T	A	A	1 5 8 8

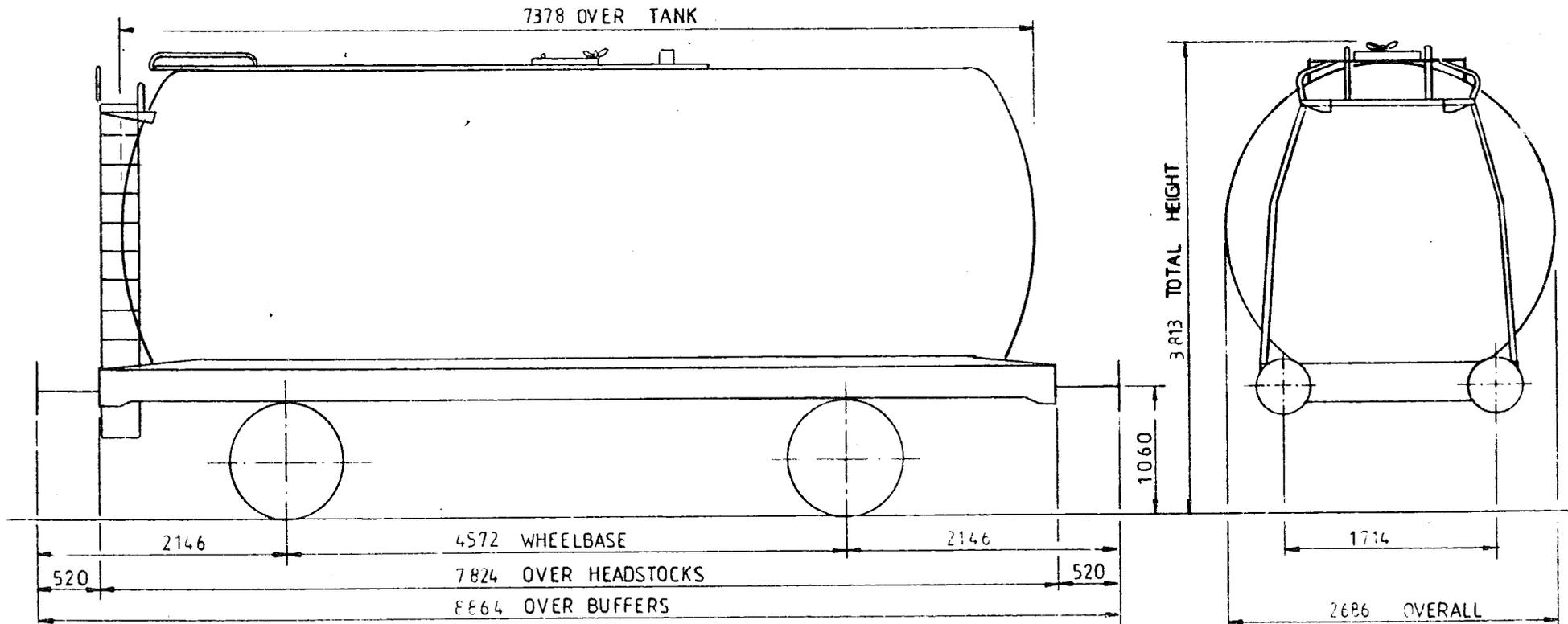

TARE	14,100 kg
CARRYING CAPACITY	31,900 kg
CAPACITY	36118 Litres
MAX SPEED	60 mile/h
WHEELS	φ 952
JOURNALS	φ140 ROLLER BEARINGS

BUFFERS	HYDRAULIC φ406 HEADS
COUPLINGS	INSTANTER
MIN CURVE	31 m
GEN ARRG'T DRG No	
BRAKE	AIR BLOCK HAND LEVER
SUSPENSION	FAT 2e

ISSUE 1

EX PO DIAGRAM 6/ 8 (ALLOCATED)

46 tonnes G.L.W. TANK WAGON BITUMEN

TT 058F

EXCESS LENGTH	4	H	M	L	E
tonnes	46	46	16	16	
VB					
AB	22	22	9	9	
RA	8	8	1	1	
MAX SPEED	60	60	60	60	

TOPS CODE										
CARKND					AARKND			OPERATIONAL PANEL		
T	T	A	T	T	A	A	8	7	2	4

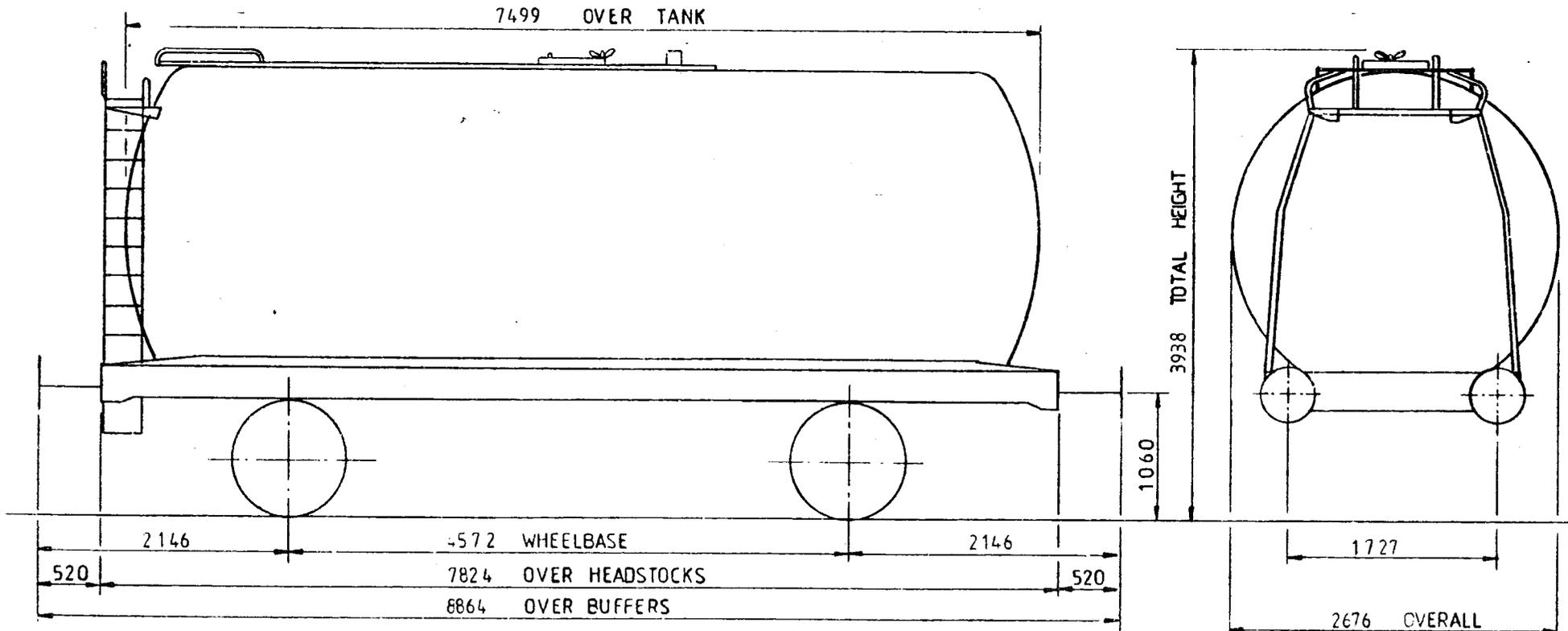

TARE	16000 kg
CARRYING CAPACITY	30000 kg
CAPACITY -	31886 Litres
MAX SPEED	60 mile/h
WHEELS	φ 952
JOURNALS	φ140 ROLLER BEARINGS

BUFFERS	HYDRAULIC φ406 HEADS
COUPLINGS	INSTANTER
MIN CURVE	31 m
GEN ARRGT DRG No	
BRAKE	AIR BLOCK HAND LEVER
SUSPENSION	FAT 26

ISSUE 1

46 tonne GLW TANK WAGON-CLASS 'B' LAGGED & COILED

LOT NUMBER	

TOPS INFORMATION						
AARKND	OPERATING	OPERATING SPEED		BRAKE FORCE DATA		EXCESS LENGTH
CARKND	PANEL No.	60 mile/h UP TO	46 tonne GLW	9t FORCE UP TO	25 tonne GLW	RA (GLW)
T T A A		mile/h ABOVE		22t FORCE ABOVE		4
						9
						DESIGN SHEET
						W1084
						W1087

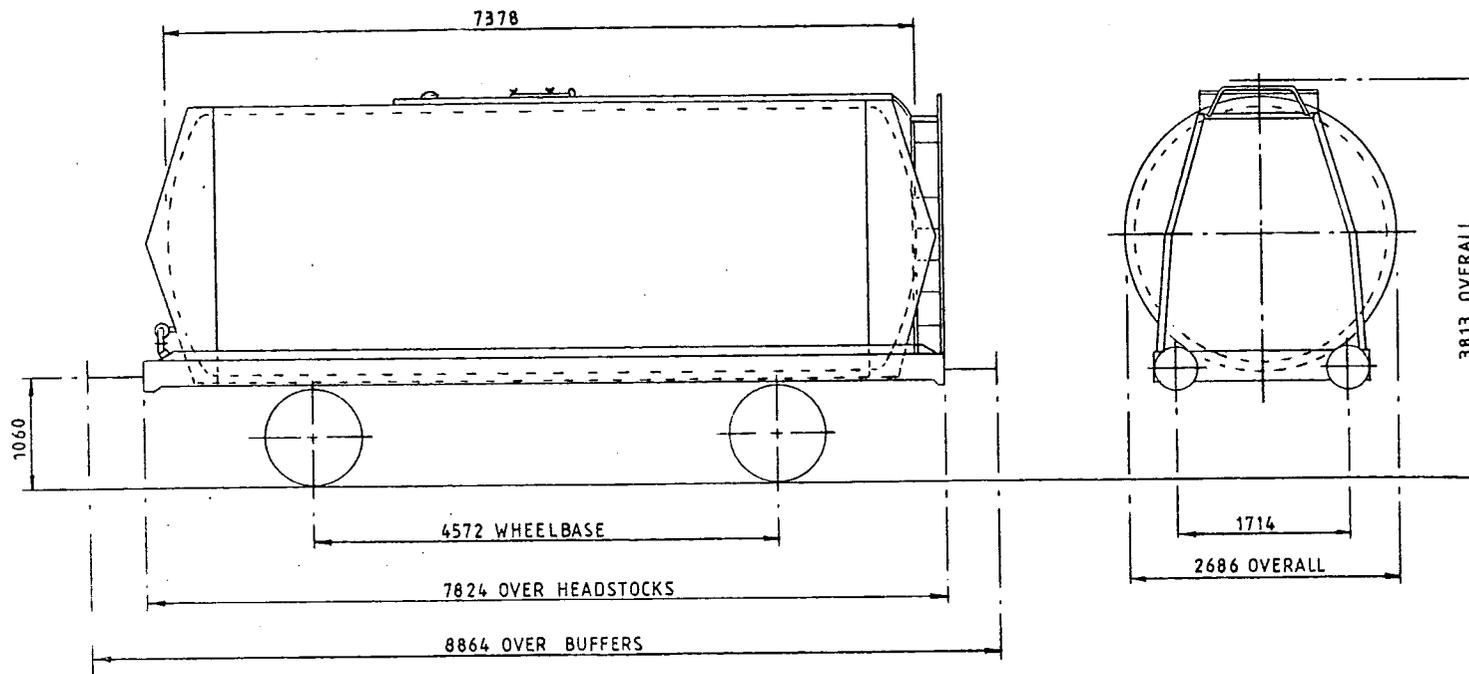

TARE-	13,600 Kg
CAPACITY, WEIGHT-	32,400 Kg
CAPACITY, VOLUME-	36.11 ⁸ litres
MIN. CURVE-	31m
GEN. ARRGT. DRG. NO.-	

BRAKE-	AIR BLOCK & HAND LEVER
SUSPENSION-	SINGLE LINK & PARABOLIC SPRING
COUPLINGS-	INSTANTER
BUFFERS-	HYDRAULIC 406 DIA HEADS
WHEELS-	952 DIA
JOURNALS-	140 DIA ROLLER BEARINGS

ISSUE 1

46 tonnes G.L.W. TANK WAGON-CLASS.B.-LAGGED & COILED.

TTO59A

EXCESS LENGTH	4	H	M	L	E
tonnes	46	46	14	14	
VB					
AB	22	22	9	9	
RA	8	8	1	1	
MAX. SPEED	60	60	45	45	

TOPS CODE										
CARKND		AARKND			OPERATING PANEL No					
T	T	A	T	T	A	A	1	5	4	0

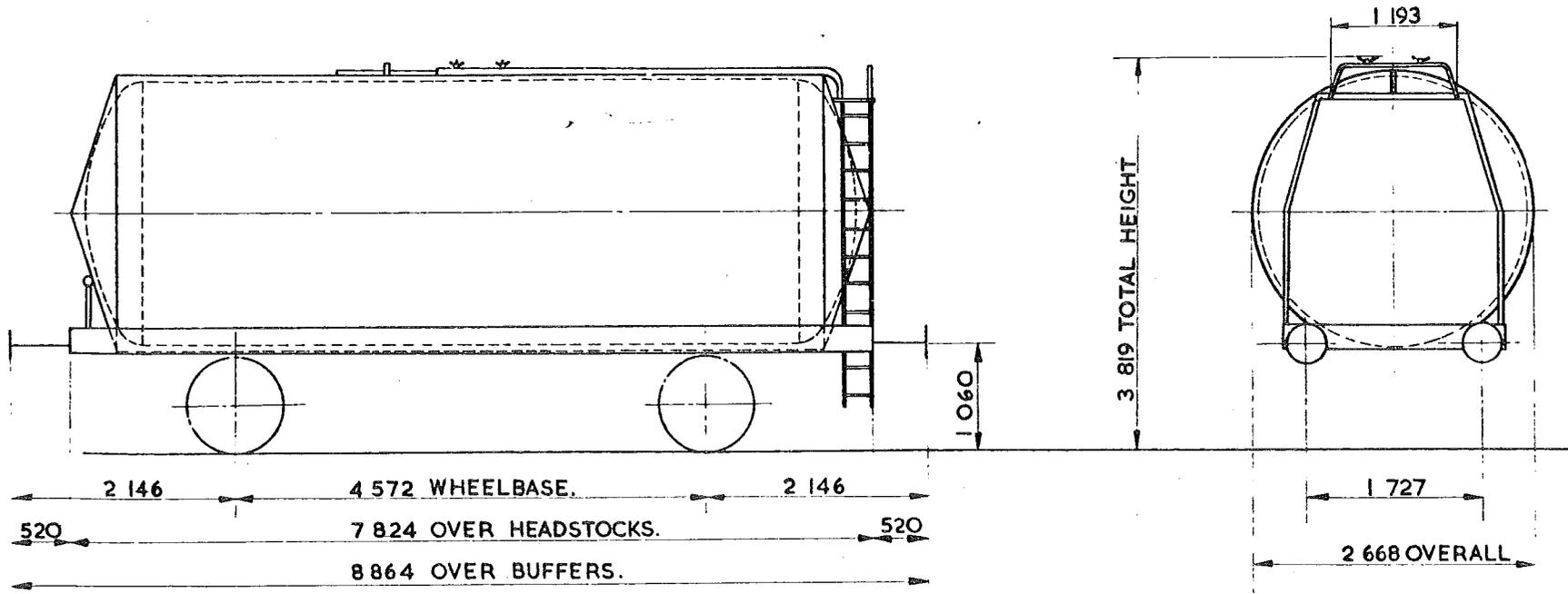

TARE	13 800 Kg.
CARRYING CAPACITY	32 200 kg
CAPACITY	35 713 litres
MAX. SPEED	60 mile/h.
WHEELS	952 DIA.
JOURNALS	140 DIA. ROLLER BEARINGS.

BUFFERS	HYDRAULIC 406 DIA. HEADS
COUPLINGS	INSTANTER.
MIN. CURVE	31 m
GEN. ARRGT. DRG. No.	-
BRAKE	AIR BLOCK & HAND LEVER
SUSPENSION	DOUBLE LINK.

BUILDER	METRO CAMELL.
OWNER	SUKO & BPO
REGISTERED BY	C.M. & E.E.(B.R.B)DERBY.
YEAR BUILT	1966/67 AND 1969.
REGISTRATION Nos.	SUKO 63200 TO 63250 BPO 63260 TO 63293
OWNERS Nos.	-

ISSUE 2

EX. PO. DIAGRAM 6/186.

46 tonnes G.L.W. TANK WAGON - CLASS B LAGGED & COILED

TTO59B

EXCESS LENGTH	4	H	M	L	E
tonnes	46	46	14	14	
VB	0	0	0	0	
AB	22	22	9	9	
RA	8	8	1	1	
MAX. SPEED	60	60	45	45	

TOPS CODE		
CARKND	AARKND	OPERATING PANEL No.
T T B	T T B A	I 5 2 6

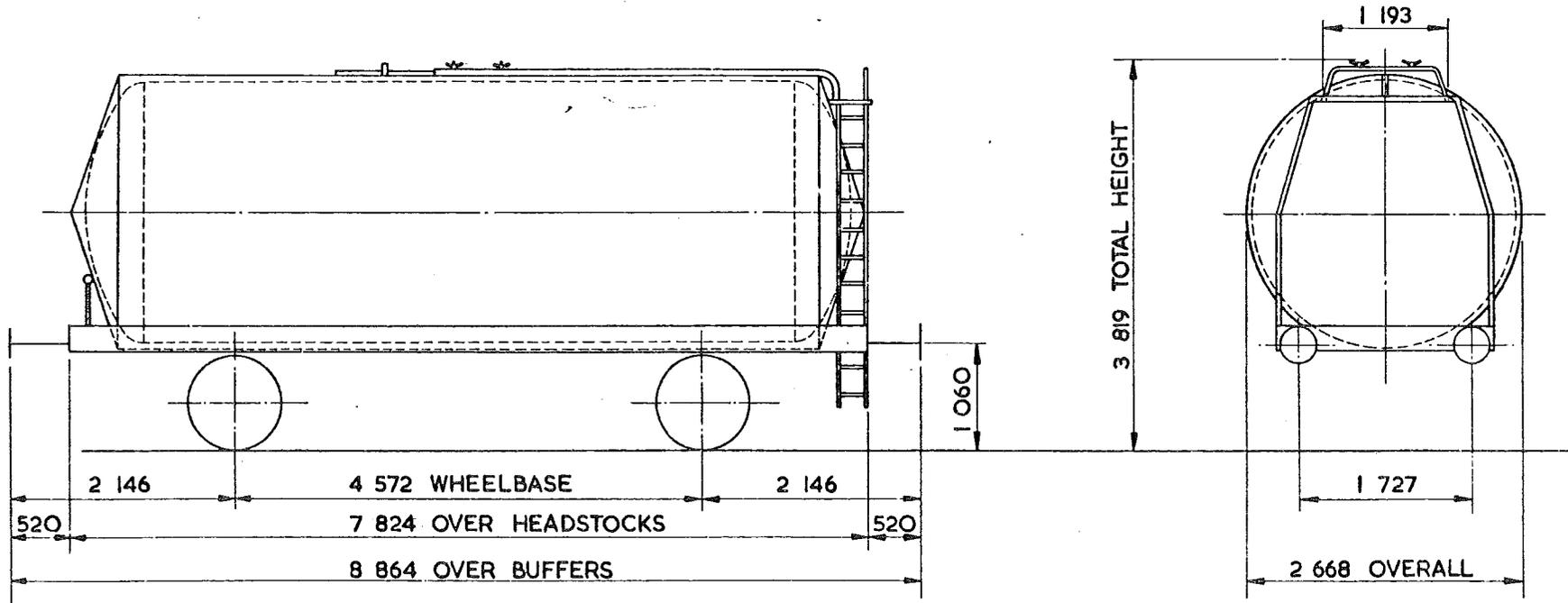

TARE -	13 800 kg
CARRYING CAPACITY -	32 200 kg
CAPACITY -	35 713 litres
MAX. SPEED -	60 mile/h
WHEELS -	952 DIA.
JOURNALS -	140 DIA. ROLLER BEARINGS

BUFFERS -	HYDRAULIC 406 DIA. HEADS
COUPLINGS -	INSTANTER
MIN. CURVE -	31 m
GEN. ARRGT. DRG. No. -	
BRAKE -	AIR BLOCK, VACUUM PIPED & HAND LEVER
SUSPENSION -	DOUBLE LINK

BUILDER -	METRO CAMELL
OWNER -	SUKO & BPO
REGISTERED BY -	C.M. & E.E. (B.R.B.) DERBY
YEAR BUILT -	1966
REGISTRATION Nos -	SUKO 63550 TO 63856 (RANGE) BPO 63560 TO 63895 (RANGE)
OWNERS Nos. -	

46 tonnes G.L.W. TANK WAGON BITUMEN

TT 059C

EXCESS LENGTH	H	M	L	E
4				
tonnes	46	46	14	14
VB	0	0	0	0
AB	22	22	9	9
RA	8	8	1	1
MAX SPEED	60	60	60	60

TOPS CODE										
CARKND		AARKND			OPERAT'N PANE N					
T	T	B	T	T	B	A	1	5	2	6

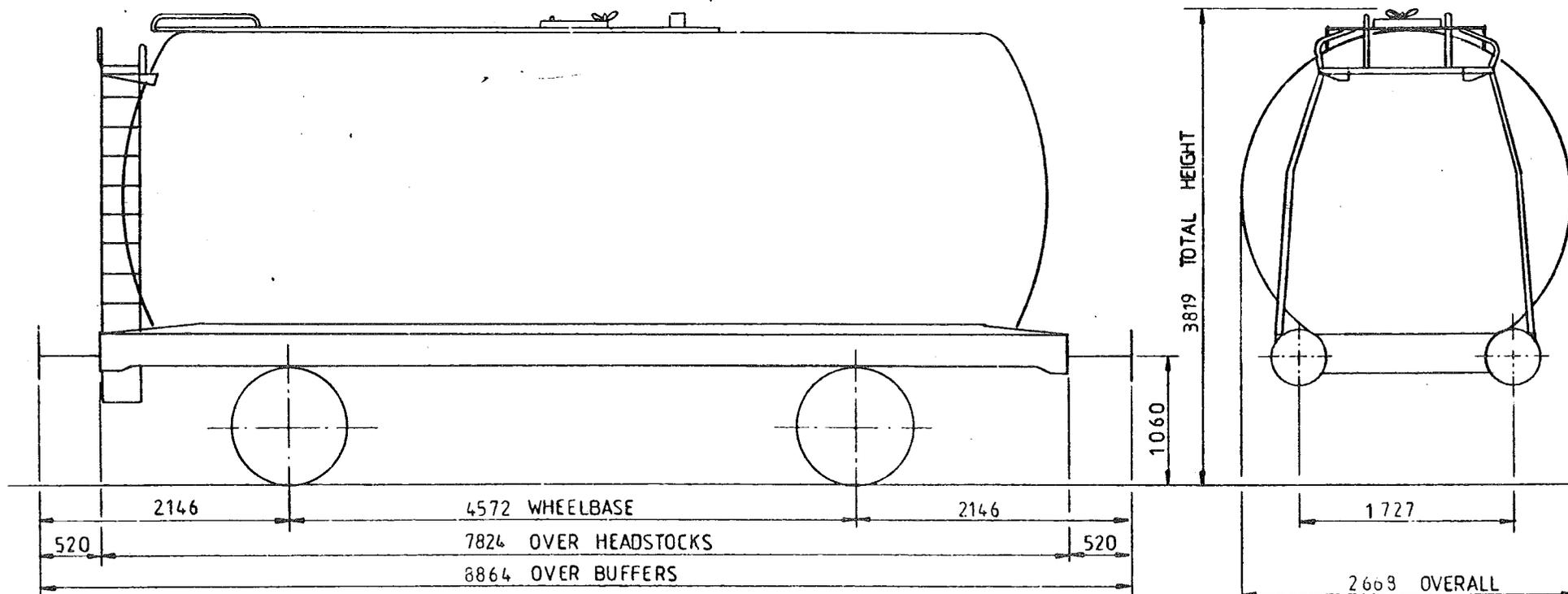

TARE	13800 kg
CARRYING CAPACITY	32000 kg
CAPACITY -	35713 Litres
MAX SPEED	60 mile/h
WHEELS	Ø 952
JOURNALS	Ø140 ROLLER BEARINGS

BUFFERS	HYDRAULIC Ø406 HEADS
COUPLINGS	INSTANTER
MIN CURVE	31 m
GEN ARRGT DRG No	
BRAKE	AIR BLOCK VACUUM PIPE, HAND LEVER
SUSPENSION	DOUBLE LINK

ISSUE 1

46 tonnes GLW. TANK WAGON CLASS A

TT 059D

EXCESS LENGTH	4	H	M	L	E
tonnes	46	46	14	14	
VB					
AB	22	22	9	9	
BA	8	8	1	1	
MAX SPEED	60	60	60	60	

TOPS CODE										
CARKND		AARKND		OPERATION PANEL						
T	T	A	T	T	A	A	1	5	8	8

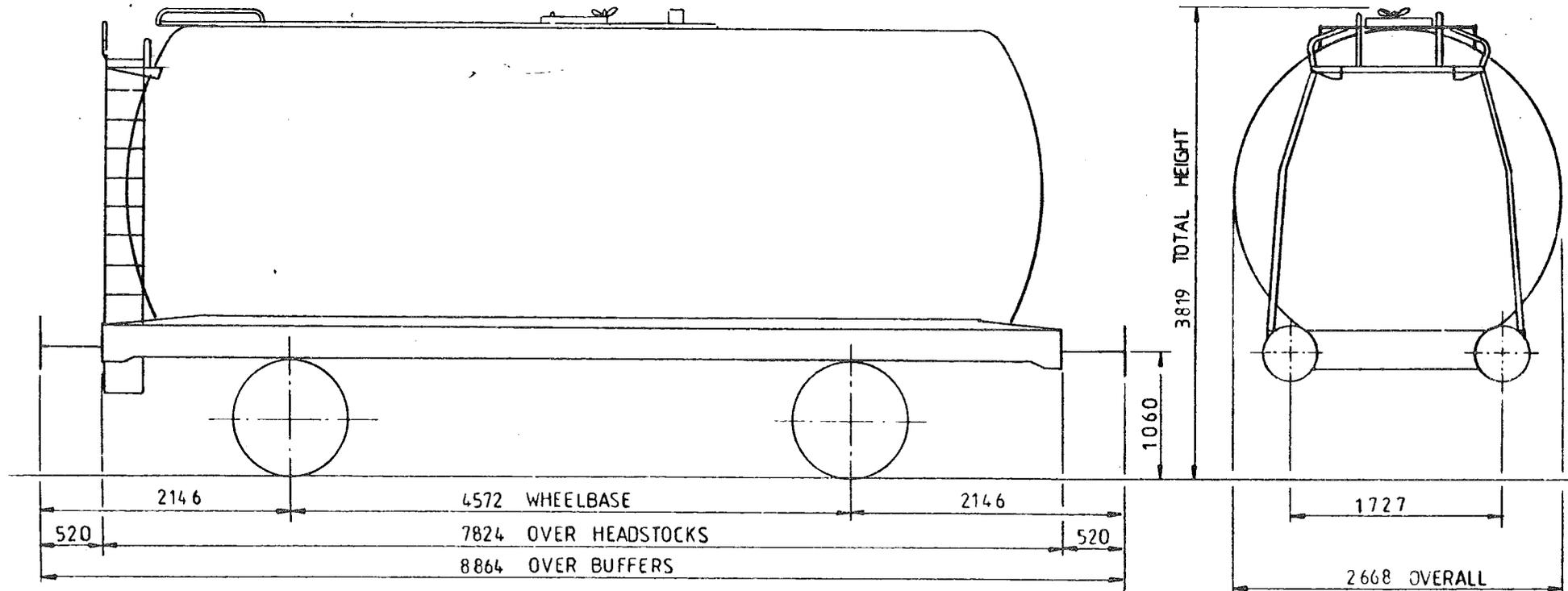

TARE	13 800 kg
CARRYING CAPACITY	32 200 kg
CAPACITY	35 713 Litres
MAX SPEED	60 mile/h
WHEELS	φ 952
JOURNALS	φ140 ROLLER BEARINGS

BUFFERS	HYDRAULIC φ406 HEADS
COUPLINGS	INSTANTER
MIN CURVE	31 m
GEN ARRGT DRG No	
BRAKE	AIR BLOCK HAND LEVER
SUSPENSION	U.I.C. DOUBLE LINK PARABOLIC SPRINGS

ISSUE 1

46 tonnes G.L.W. TANK WAGON CLASS A

TT 059G

EXCESS LENGTH	4	H	M	L	E
tonnes	46	46	14	14	
VB					
AB	22	22	9	9	
RA	8	8	1	1	
MAX SPEED	60	60	60	60	

TOPS CODE										
CARKND			AARKND			OPERATION PANEL N				
T	T	A	T	T	A	A	1	5	8	9

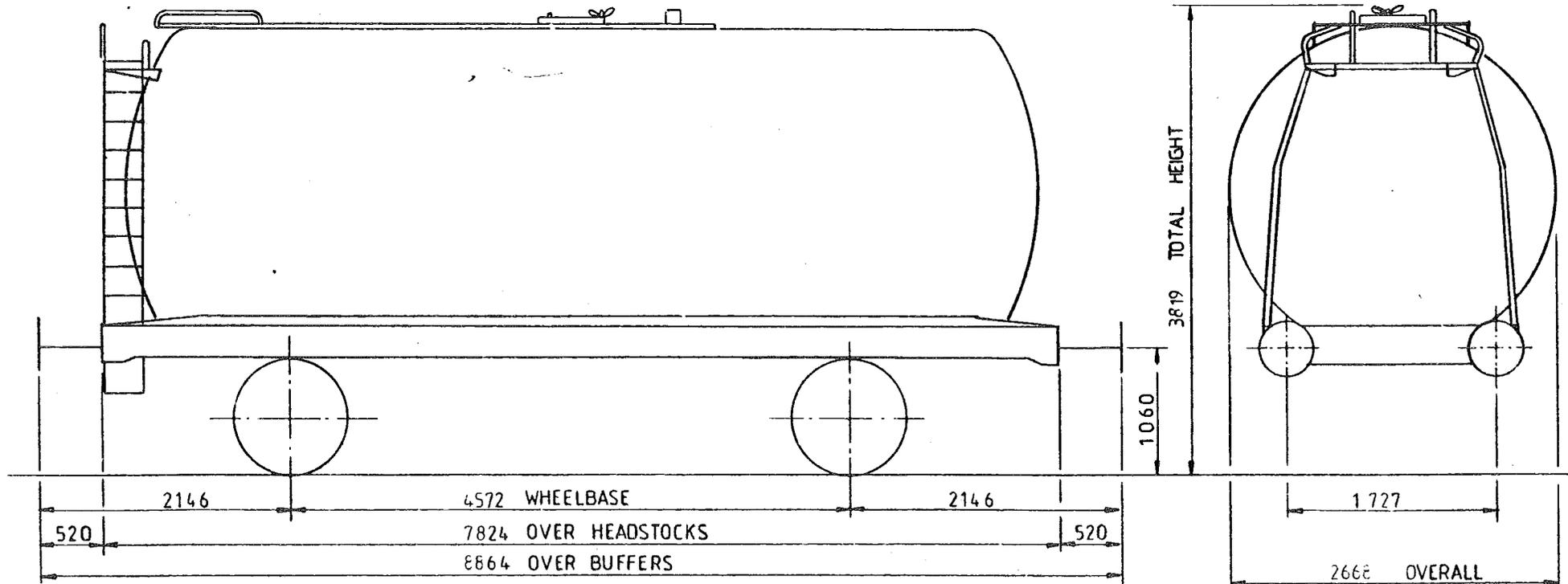

TARE	13 800 kg
CARRYING CAPACITY	32 000 kg
CAPACITY	35713 Litres
MAX SPEED	60 mile/h
WHEELS	φ 952
JOURNALS	φ140 ROLLER BEARINGS

BUFFERS	HYDRAULIC φ406 HEADS
COUPLINGS	INSTANTER
MIN CURVE	31 m
GEN ARRGT DRG No	
BRAKE	AIR BLOCK HAND LEVER
SUSPENSION	U.I.C. DOUBLE LINK, PARABOLIC SPRINGS

ISSUE 1

46 tonnes GLW. TANK WAGON CLASS B

TT 059H

EXCESS LENGTH	4	H	M	L	E
tonnes	46	46	14	14	
VB					
AB	22	22	9	9	
RA	8	8	1	1	
MAX SPEED	60	60	60	60	

TOPS CODE										
CARKND		AARKND			OPERATION PANEL					
T	T	A	T	T	A	A	1	5	8	8

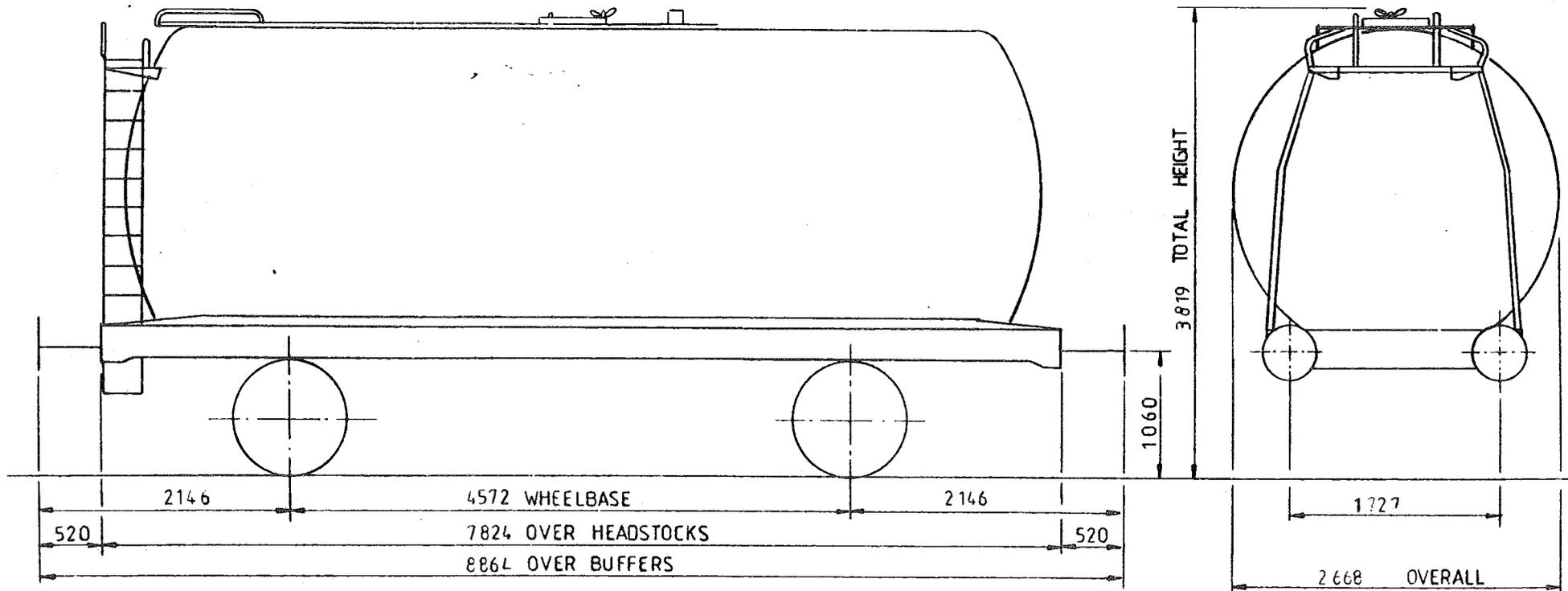

TARE	13200 kg
CARRYING CAPACITY -	32000 kg
CAPACITY -	35713 Litres
MAX SPEED	60 mile/h
WHEELS	φ 952
JOURNALS	φ140 ROLLER BEARINGS

BUFFERS	HYDRAULIC φ406 HEADS
COUPLINGS	INSTANTER
MIN CURVE	31 m
GEN ARRGT DRG No	
BRAKE	AIR BLOCK HAND LEVER
SUSPENSION	FAT 26

ISSUE 1

46 tonnes G.L.W. TANK WAGON CLASS B

TT 059J

EXCESS LENGTH	L	H	M	L	E
tonnes	46	46	14	14	
VB					
AB	22	22	9	9	
RA	8	8	1	1	
MAX SPEED	60	60	60	60	

TOPS CODE							
CARKND	AARKND			OPERATING PANEL			
T	T	A	T	T	A	A	1 5 8 8

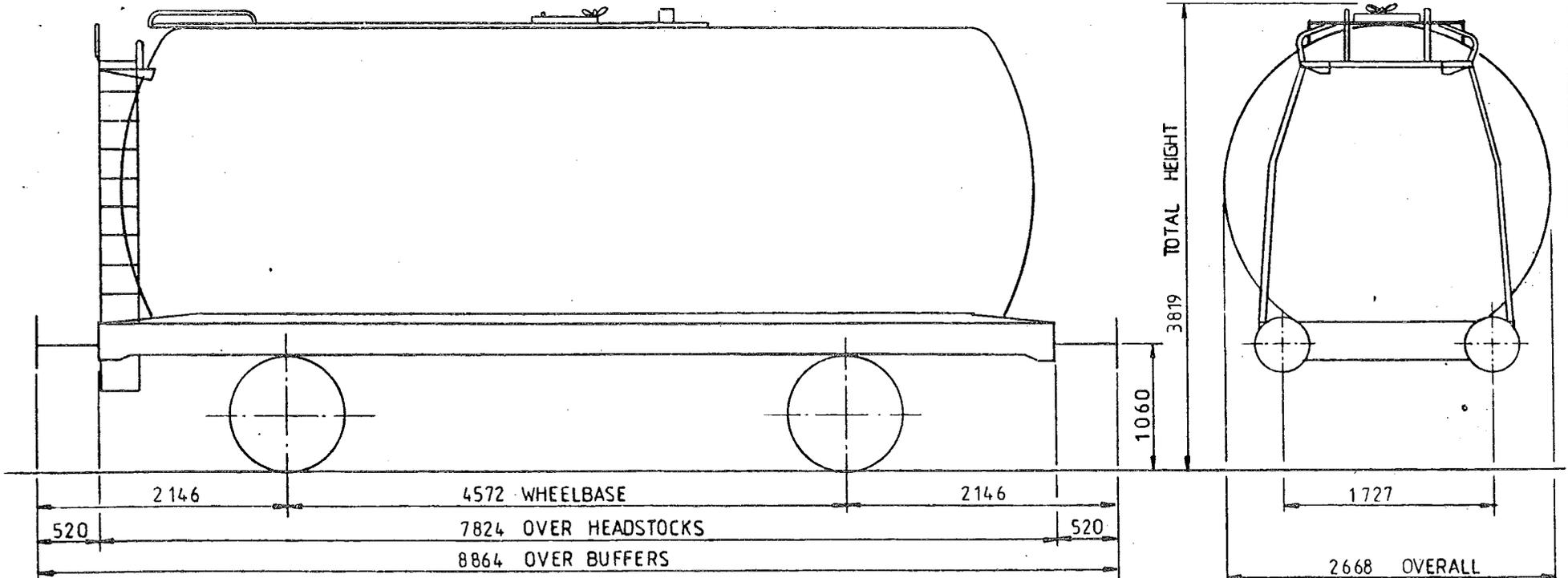

TARE	13 800 kg
CARRYING CAPACITY	32 000 kg
CAPACITY	35 713 Litres
MAX SPEED	60 mile/h
WHEELS	φ 952
JOURNALS	φ140 ROLLER BEARINGS

BUFFERS	HYDRAULIC φ406 HEADS
COUPLINGS	INSTANTER
MIN CURVE	31 m
GEN ARRGT DRG No	
BRAKE	AIR BLOCK HAND LEVER
SUSPENSION	SHORT SINGLE LINK

ISSUE 2

EX PO DIAGRAM 6/186 (ALLOCATED)

46 tonne GLW TANK WAGON-CLASS 'B' - LAGGED & COILED

LOT NUMBER	

TOPS INFORMATION						
AARKND	OPERATING	OPERATING SPEED		BRAKE FORCE DATA		EXCESS LENGTH
CARKND	PANEL No.	60 mile/h UP TO	46 tonne GLW	9t FORCE UP TO	25 tonne GLW	RA (GLW)
T T A A		mile/h ABOVE		22t FORCE ABOVE		DESIGN SHEET
						WIO64
						4
						9

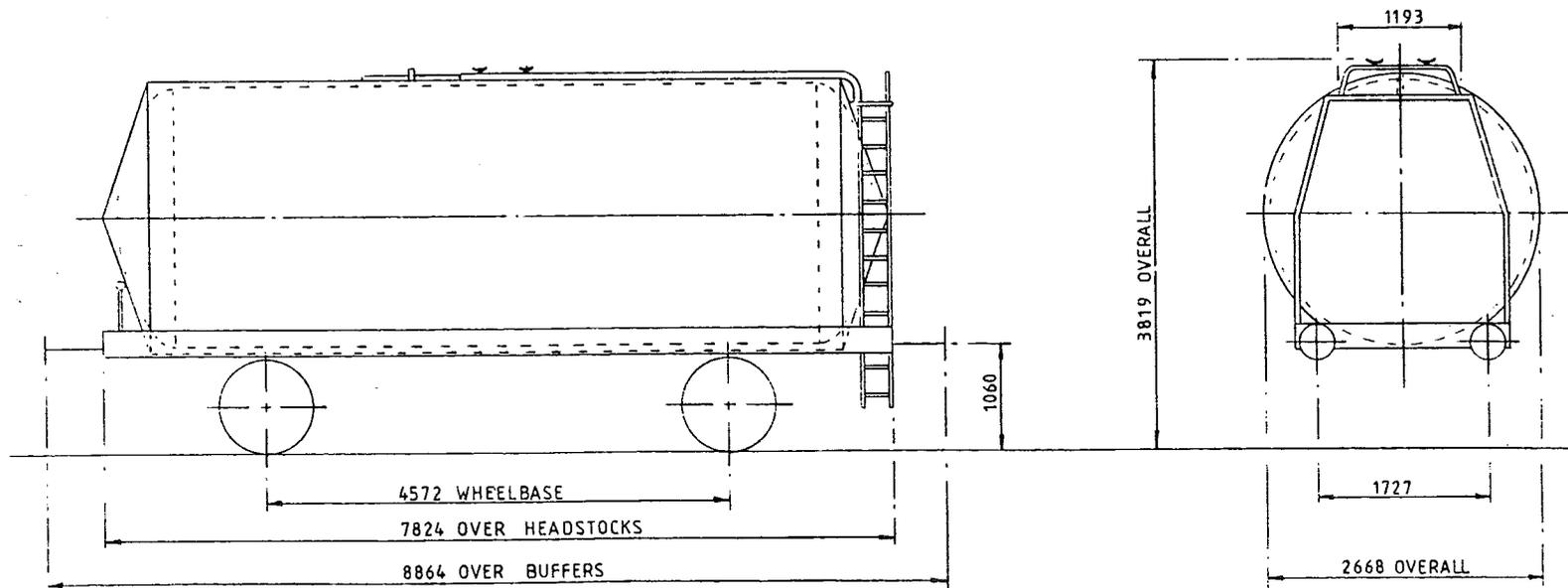

TARE-	13,700 Kg
CAPACITY, WEIGHT-	32,300 Kg
CAPACITY, VOLUME-	35.713 litres
MIN. CURVE-	31m
GEN. ARRGT. DRG. NO.-	

BRAKE-	AIR BLOCK & HAND LEVER
SUSPENSION-	DOUBLE LINK & PARABOLIC SPRING
COUPLINGS-	INSTANTER
BUFFERS-	HYDRAULIC 406 DIA HEADS
WHEELS-	952 DIA
JOURNALS-	140 DIA ROLLER BEARINGS

ISSUE I

46tonne GLW TANK WAGON - CLASS 'B'

LOT NUMBER	

TOPS INFORMATION									
AARKND	OPERATING		OPERATING SPEED		BRAKE FORCE DATA		EXCESS LENGTH	RA (GLW)	DESIGN SHEET
CARKND	PANEL No.		60 mile/h UP TO 46 tonne GLW		9t FORCE UP TO 25tonne GLW		4	9	W1083
T T A	A		mile/h ABOVE		22t FORCE ABOVE				W1088
									W1089

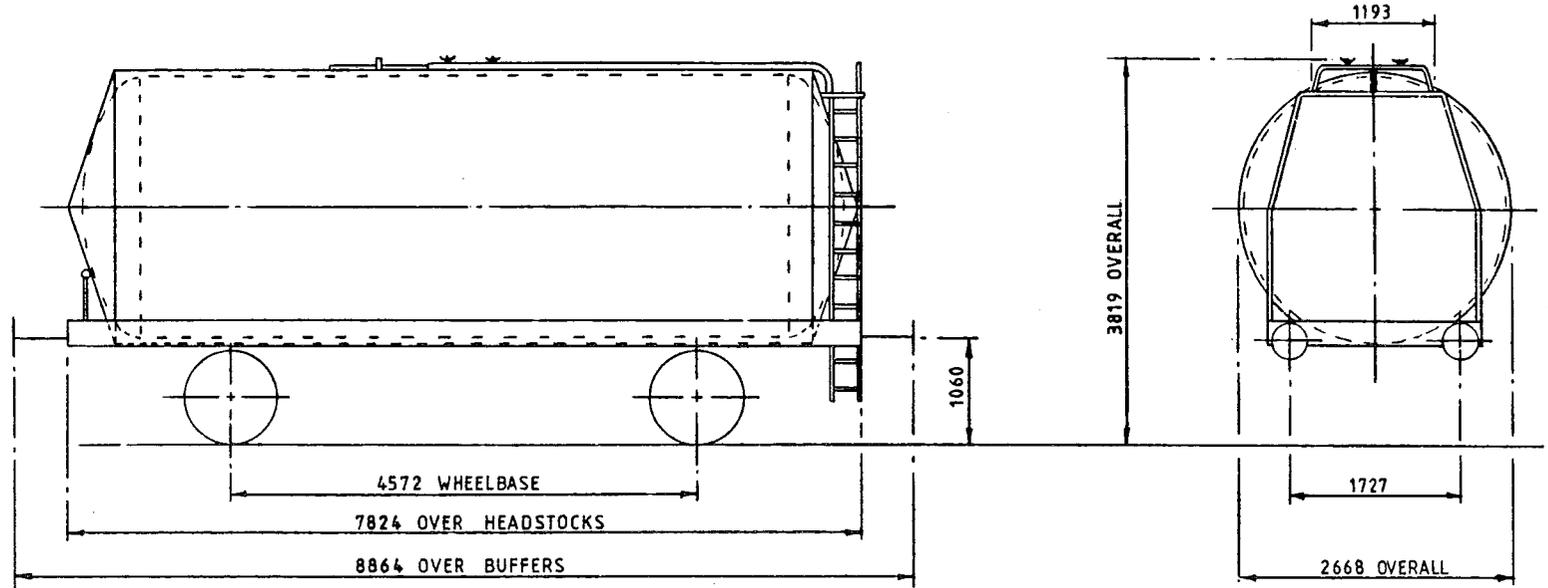

TARE-	13.600 Kg
CAPACITY, WEIGHT-	32.400 Kg
CAPACITY, VOLUME-	35.713 litres
MIN. CURVE-	31m
GEN. ARRGT. DRG. NO.-	

BRAKE-	AIR BLOCK & HAND LEVER
SUSPENSION-	SINGLE LINK & PARABOLIC SPRING
COUPLINGS-	INSTANTER
BUFFERS-	HYDRAULIC 406 DIA HEADS
WHEELS-	952 DIA
JOURNALS-	140 DIA ROLLER BEARINGS

ISSUE 1

46 tonne GLW TANK WAGON - CLASS 'B'

LOT NUMBER	

TOPS INFORMATION										
AARKND	OPERATING			OPERATING SPEED		BRAKE FORCE DATA		EXCESS LENGTH	RA (GLW)	DESIGN SHEET
CARKND	PANEL No.			60 mile/h UP TO		9t FORCE UP TO		4	9	W1085
T T B A				mile/h ABOVE		22t FORCE ABOVE				

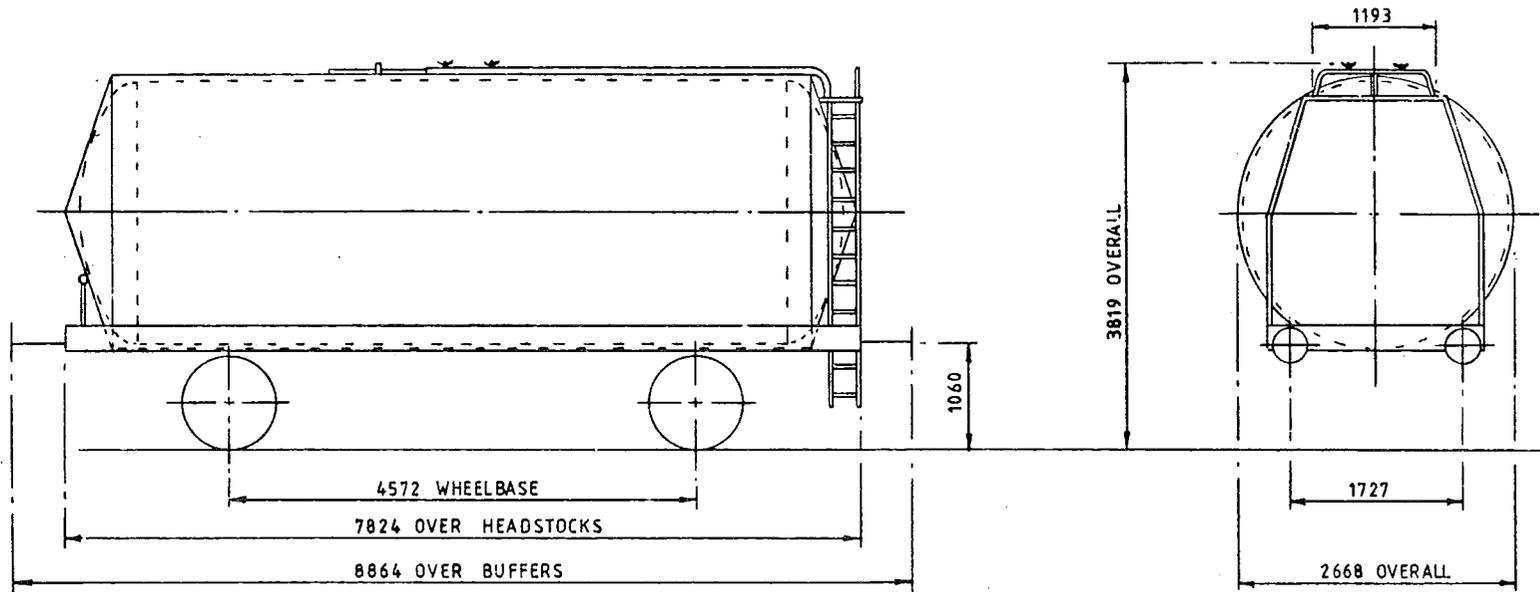

TARE-	13,700 Kg
CAPACITY, WEIGHT-	32,300 Kg
CAPACITY, VOLUME-	35.713 litres
MIN. CURVE-	31m
GEN. ARRGT. DRG. NO.-	

BRAKE-	AIR BLOCK, VAC. PIPE, HAND LEVER
SUSPENSION-	SINGLE LINK & PARABOLIC SPRING
COUPLINGS-	INSTANTER
BUFFERS-	HYDRAULIC 406 DIA HEADS
WHEELS-	952 DIA
JOURNALS-	140 DIA ROLLER BEARINGS

ISSUE 1

46 tonne GLW TANK WAGON - BITUMEN

LOT NUMBER	

TOPS INFORMATION						
AARKND	OPERATING	OPERATING SPEED		BRAKE FORCE DATA		EXCESS LENGTH
CARKND	PANEL No.	45 mile/h UP TO	13.8 tonne GLW	9t FORCE UP TO	25tonne GLW	RA (GLW)
T T A A		60 mile/h ABOVE		22t FORCE ABOVE		4
						9
						W1248

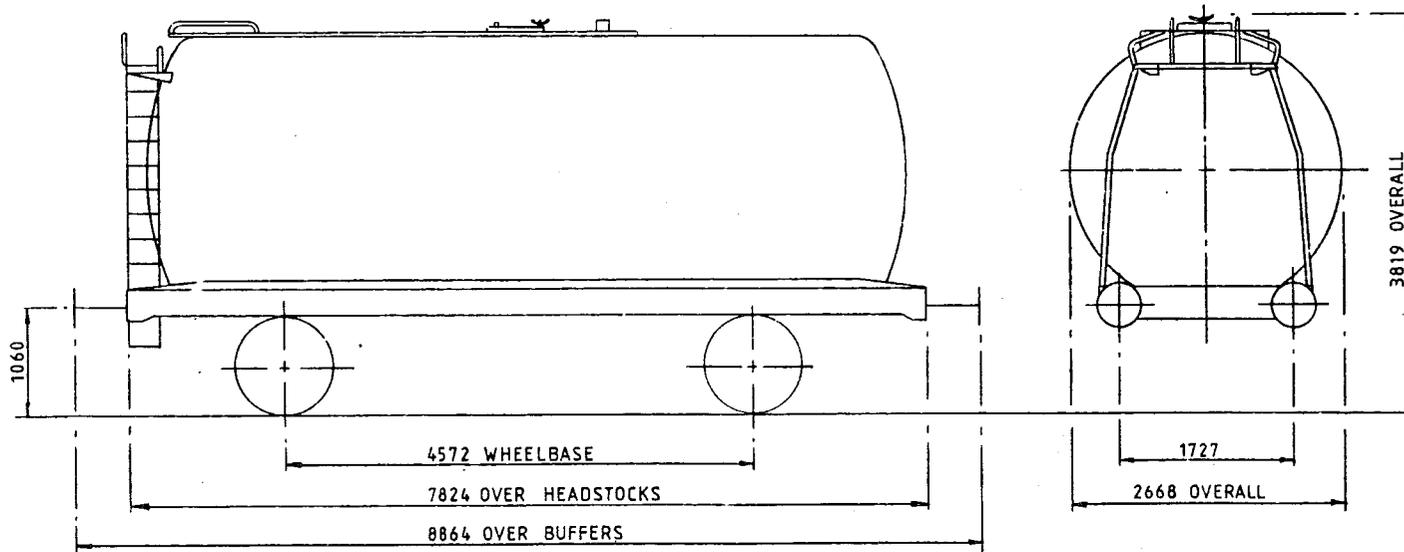

TARE-	13,800 Kg
CAPACITY, WEIGHT-	32,000 Kg
CAPACITY, VOLUME-	35.713 litres
MIN. CURVE-	31 m
GEN. ARRGT. DRG. NO.-	

BRAKE-	AIR BLOCK & HAND LEVER
SUSPENSION-	DOUBLE LINK
COUPLINGS-	INSTANTER
BUFFERS-	HYDRAULIC 406 DIA HEADS
WHEELS-	952 DIA
JOURNALS-	140 DIA ROLLER BEARINGS

ISSUE 1

46tonne GLW TANK WAGON - CLASS A

LOT NUMBER	

TOPS INFORMATION											
AARKND		OPERATING		OPERATING SPEED			BRAKE FORCE DATA		EXCESS LENGTH	RA (GLW)	DESIGN SHEET
CARKND		PANEL No.		45 mile/h UP TO 13.8 tonne GLW			9t FORCE UP TO 25tonne GLW		4	9	W1300
T	T	A	A								

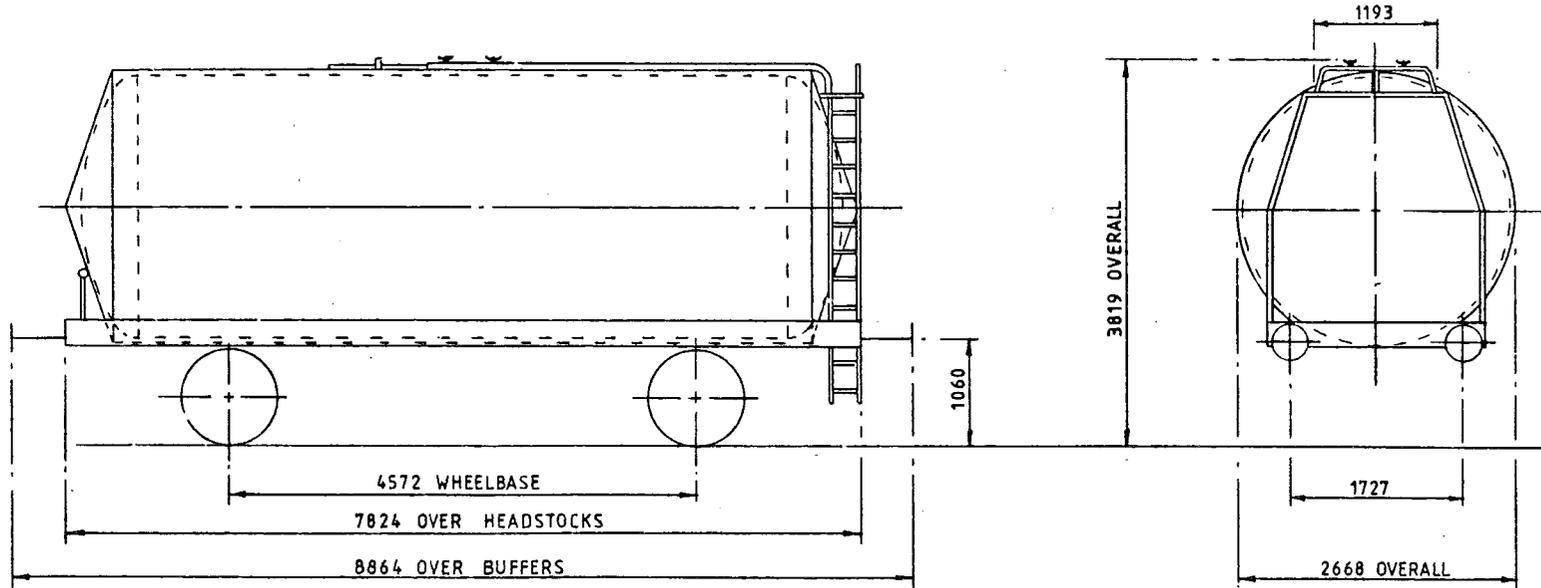

TARE-	13,800 Kg
CAPACITY, WEIGHT-	32,200Kg
CAPACITY, VOLUME-	35,713 litres
MIN. CURVE-	31m
GEN. ARRGT. DRG. NO.-	

BRAKE-	AIR BLOCK & HAND LEVER
SUSPENSION-	DOUBLE LINK
COUPLINGS-	INSTANTER
BUFFERS-	HYDRAULIC 406 DIA HEADS
WHEELS-	952 DIA
JOURNALS-	140 DIA ROLLER BEARINGS

ISSUE 1

46 tonne GLW BITUMEN TANK WAGON

LOT NUMBER	

TOPS INFORMATION									
AARKND	OPERATING		OPERATING SPEED		BRAKE FORCE DATA		EXCESS LENGTH	RA (GLW)	DESIGN SHEET
CARKND	PANEL No.		60 mile/h UP TO	46 tonne GLW	9t FORCE UP TO	25 tonne GLW	4	9	W 281 W 1521
T T A A			mile/h ABOVE		22t FORCE ABOVE				

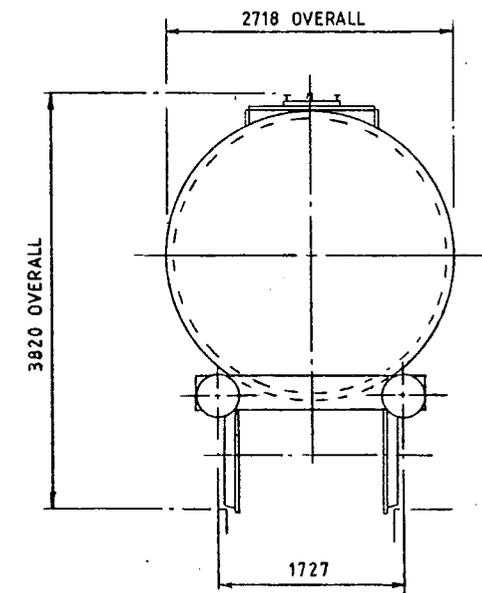
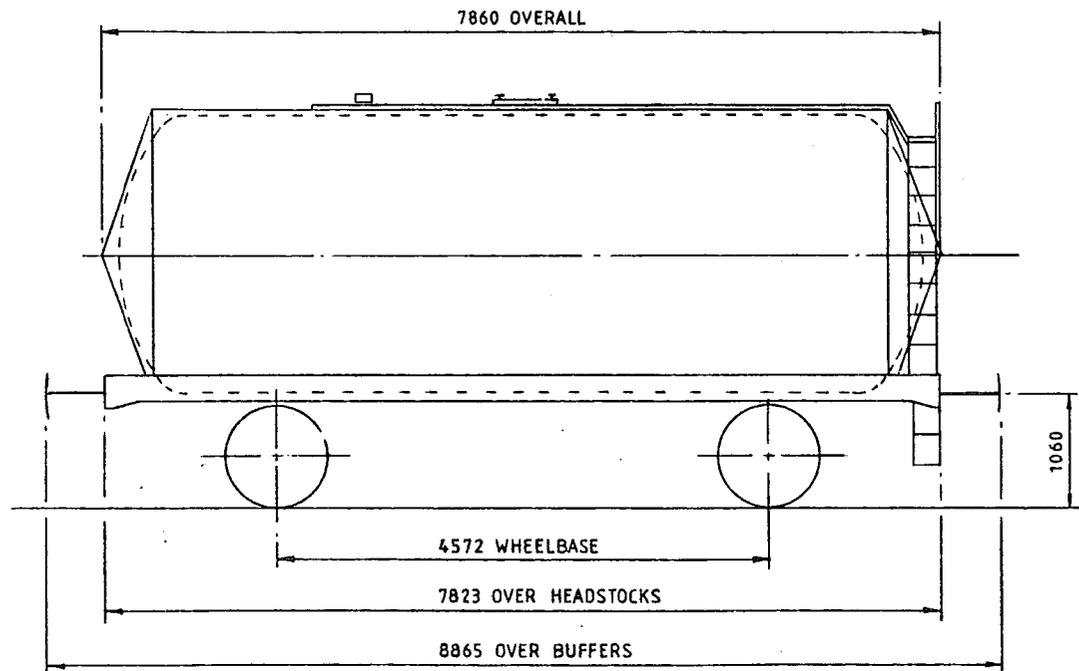

TARE-	15,350 Kg
CAPACITY, WEIGHT-	30,650 Kg
CAPACITY, VOLUME-	34,580 litres
MIN. CURVE-	50 m
GEN. ARRGT. DRG. NO.-	

BRAKE-	AIR, C.I. BLOCK, SINGLE PRESSURE, E/L CONTROL
SUSPENSION-	DOUBLE LINK
COUPLINGS-	INSTANTER
BUFFERS-	HYDRAULIC 406 DIA HEAD
WHEELS-	952 DIA
JOURNALS-	5 1/2" DIA

ISSUE 1

46 tonne GLW TANK WAGON - L.P.G.

LOT NUMBER	

TOPS INFORMATION										
AARKND		OPERATING		OPERATING SPEED		BRAKE FORCE DATA		EXCESS LENGTH	RA (GLW)	DESIGN SHEET
CARKND		PANEL No.		60 mile/h UP TO 46 tonne GLW		9t FORCE UP TO 25 tonne GLW		4	9	W1442
T	T	A	A							

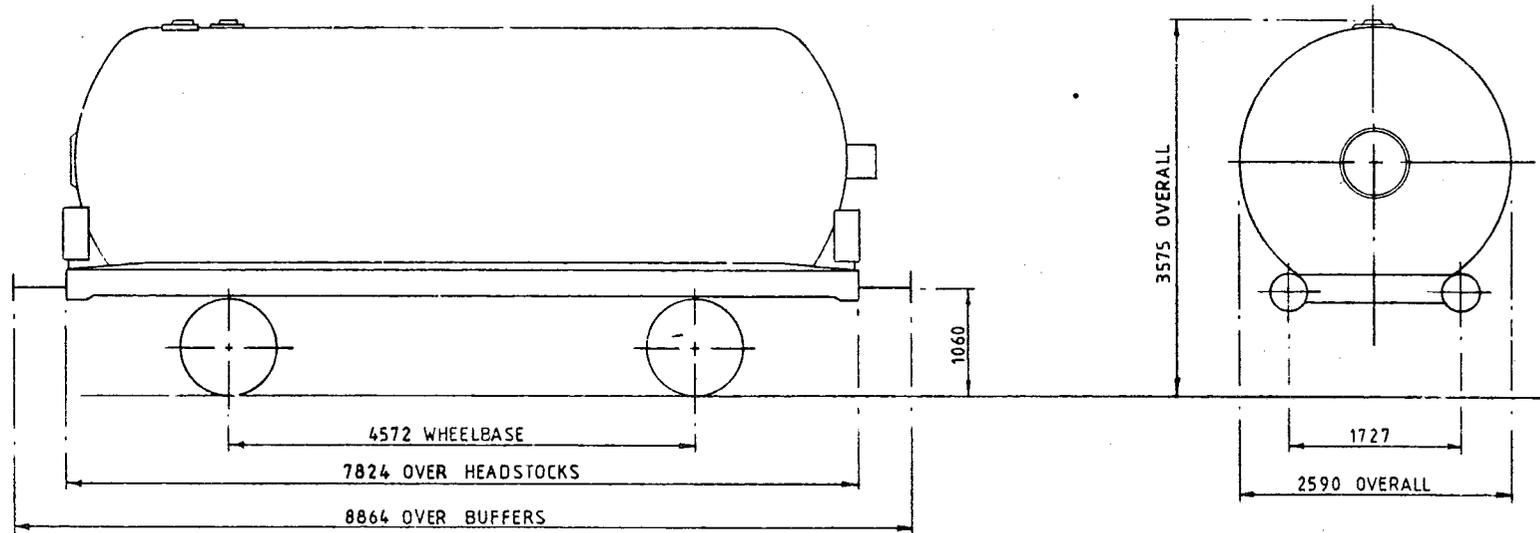

TARE-	21,500 Kg
CAPACITY, WEIGHT-	24,500 Kg
CAPACITY, VOLUME-	
MIN. CURVE-	31 m
GEN. ARRGT. DRG. NO.-	

BRAKE-	AIR BLOCK & HAND LEVER
SUSPENSION-	SHORT SINGLE LINK & PARABOLIC SPRING
COUPLINGS-	INSTANTER
BUFFERS-	HYDRAULIC 406 DIA HEADS
WHEELS-	952 DIA
JOURNALS-	140 DIA ROLLER BEARINGS

ISSUE 1

46tonne GLW TANK WAGON - L.P.G.

LOT NUMBER	

TOPS INFORMATION						
AARKND	OPERATING	OPERATING SPEED		BRAKE FORCE DATA		EXCESS LENGTH
CARKND	PANEL No.	60 mile/h UP TO	46 tonne GLW	9t FORCE UP TO	25 tonne GLW	RA (GLW)
T T A A		mile/h ABOVE		22t FORCE ABOVE		DESIGN SHEET
						W1443

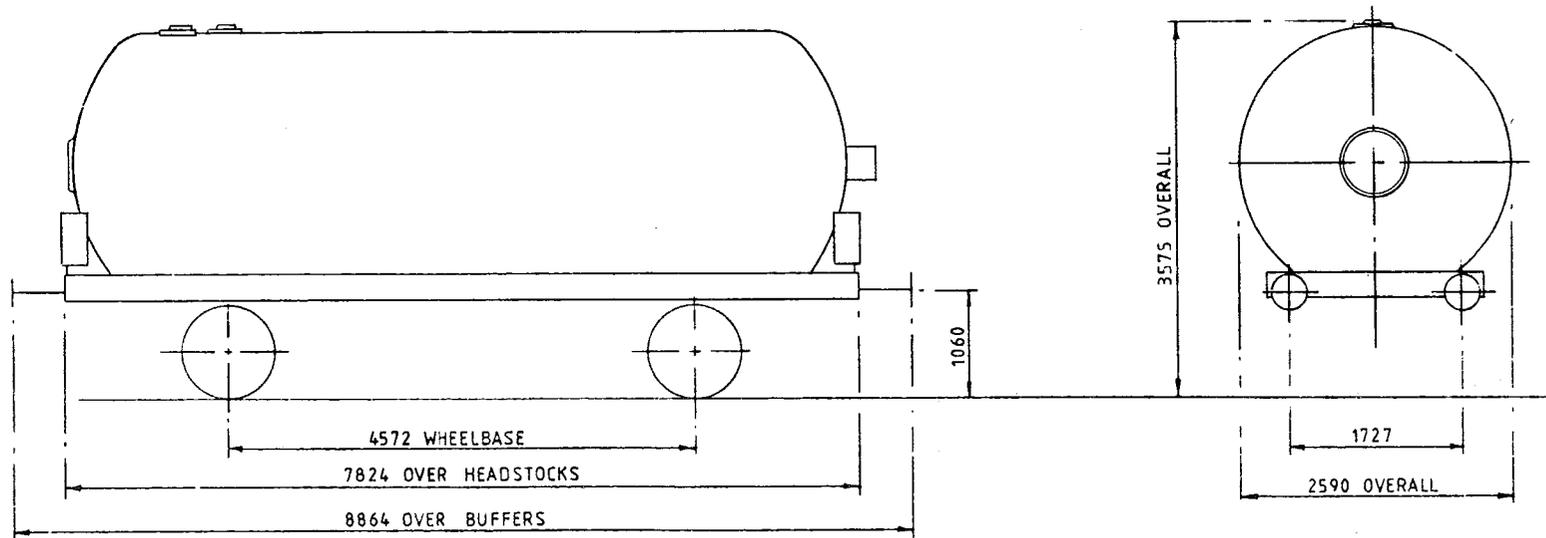

TARE-	21,550 Kg
CAPACITY, WEIGHT-	24,450 Kg
CAPACITY, VOLUME-	
MIN. CURVE-	31m
GEN. ARRGT. DRG. NO.-	

BRAKE-	AIR BLOCK & HAND LEVER
SUSPENSION-	SHORT SINGLE LINK & PARABOLIC SPRING
COUPLINGS-	INSTANTER
BUFFERS-	HYDRAULIC 406 DIA HEADS
WHEELS-	952 DIA
JOURNALS-	140 DIA ROLLER BEARINGS

ISSUE 1

46 tonne GLW TANK WAGON - BITUMEN

LOT NUMBER	

TOPS INFORMATION						
AARKND	OPERATING	OPERATING SPEED		BRAKE FORCE DATA		EXCESS LENGTH
CARKND	PANEL No.	60 mile/h UP TO	46 tonne GLW	9t FORCE UP TO	25 tonne GLW	RA (GLW)
T T A A		mile/h ABOVE		22t FORCE ABOVE		4
						9
						DESIGN SHEET W1118

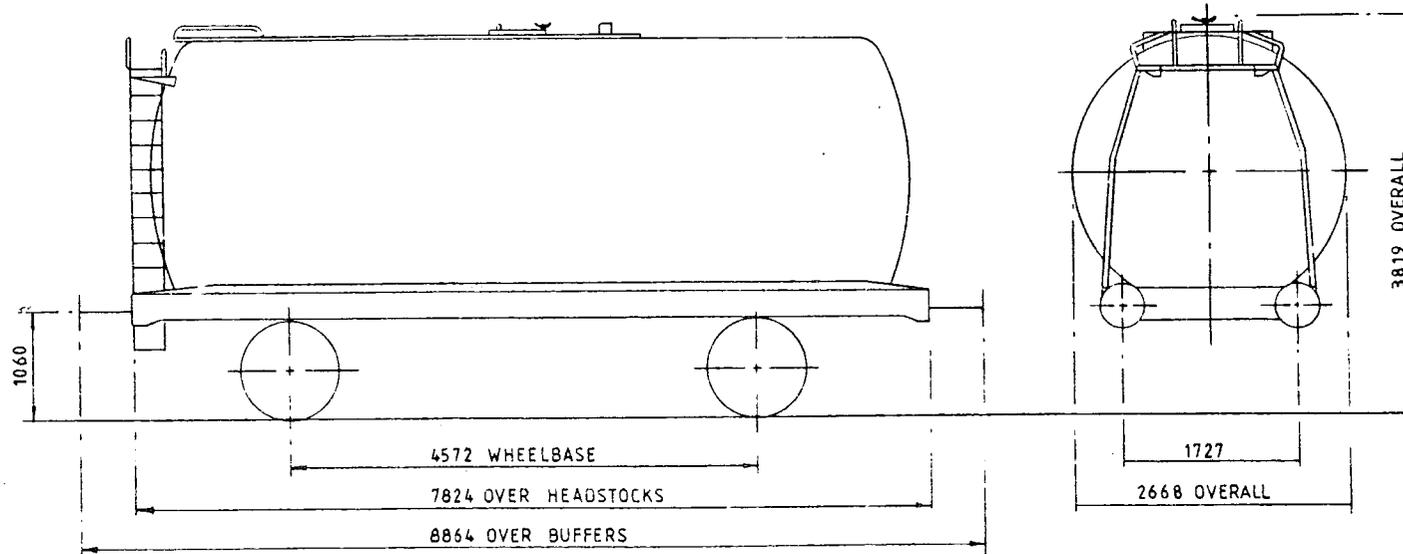

TARE-	15 650 Kg
CAPACITY, WEIGHT-	30 350 Kg
CAPACITY, VOLUME-	35.713 litres
MIN. CURVE-	31 m
GEN. ARRGT. DRG. NO.-	

BRAKE-	AIR BLOCK, VAC. PIPE, HAND LEVER
SUSPENSION-	SINGLE LINK & PARABOLIC SPRING
COUPLINGS-	INSTANTER
BUFFERS-	HYDRAULIC 406 DIA HEADS
WHEELS-	952 DIA
JOURNALS-	140 DIA ROLLER BEARINGS

ISSUE I

46 tonne GLW TANK WAGON BITUMEN

LOT NUMBER	

TOPS INFORMATION						
AARKND	OPERATING	OPERATING SPEED		BRAKE FORCE DATA		EXCESS LENGTH
CARKND	PANEL No.	60 mile/h UP TO	46 tonne GLW	9t FORCE UP TO	25 tonne GLW	RA (GLW)
T T A A		mile/h ABOVE		22t FORCE ABOVE		4
						9
						WI484

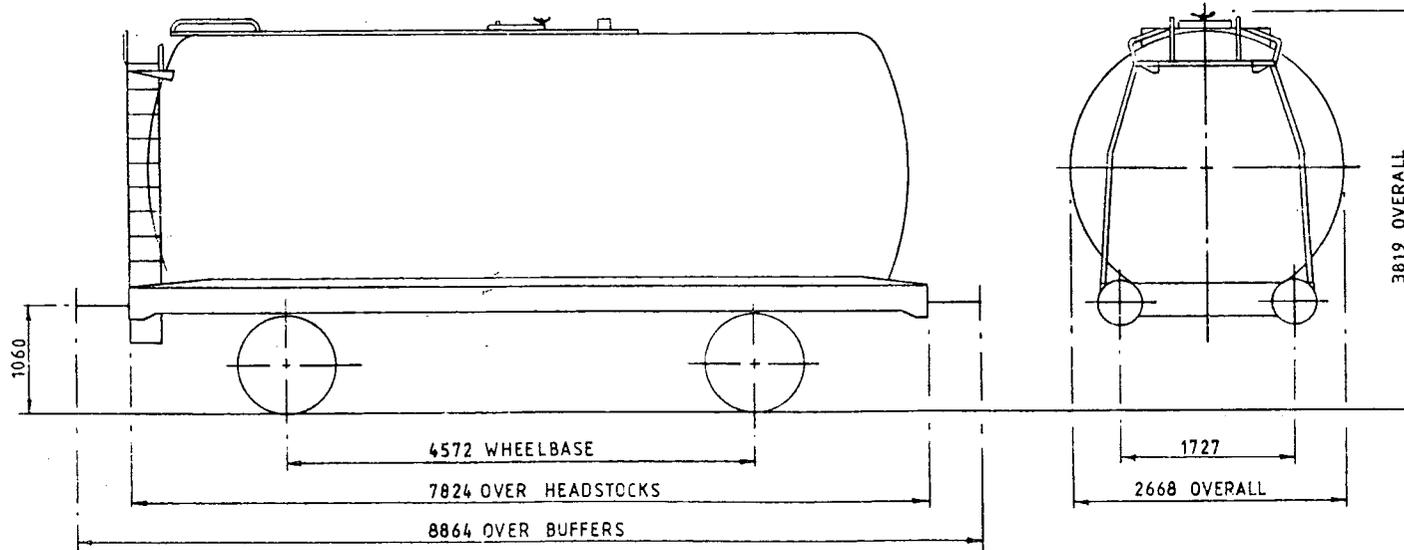

TARE-	15,150 Kg
CAPACITY, WEIGHT-	30,850 Kg
CAPACITY, VOLUME-	35.713 litres
MIN. CURVE-	31 m
GEN. ARRGT. DRG. NO.-	

BRAKE-	AIR BLOCK & HAND LEVER
SUSPENSION-	SINGLE LINK & PARABOLIC SPRING
COUPLINGS-	INSTANTER
BUFFERS-	HYDRAULIC 406 DIA HEADS
WHEELS-	952 DIA
JOURNALS-	140 DIA ROLLER BEARINGS

ISSUE I

46tonne GLW TANK WAGON - CLASS 'B' LAGGED & COILED

LOT NUMBER	

TOPS INFORMATION						
AARKND	OPERATING	OPERATING SPEED		BRAKE FORCE DATA		EXCESS LENGTH
CARKND	PANEL No.	60 mile/h UP TO	46 tonne GLW	9 t FORCE UP TO	25 tonne GLW	4
T T A		mile/h ABOVE		22 t FORCE ABOVE		8
						W1615

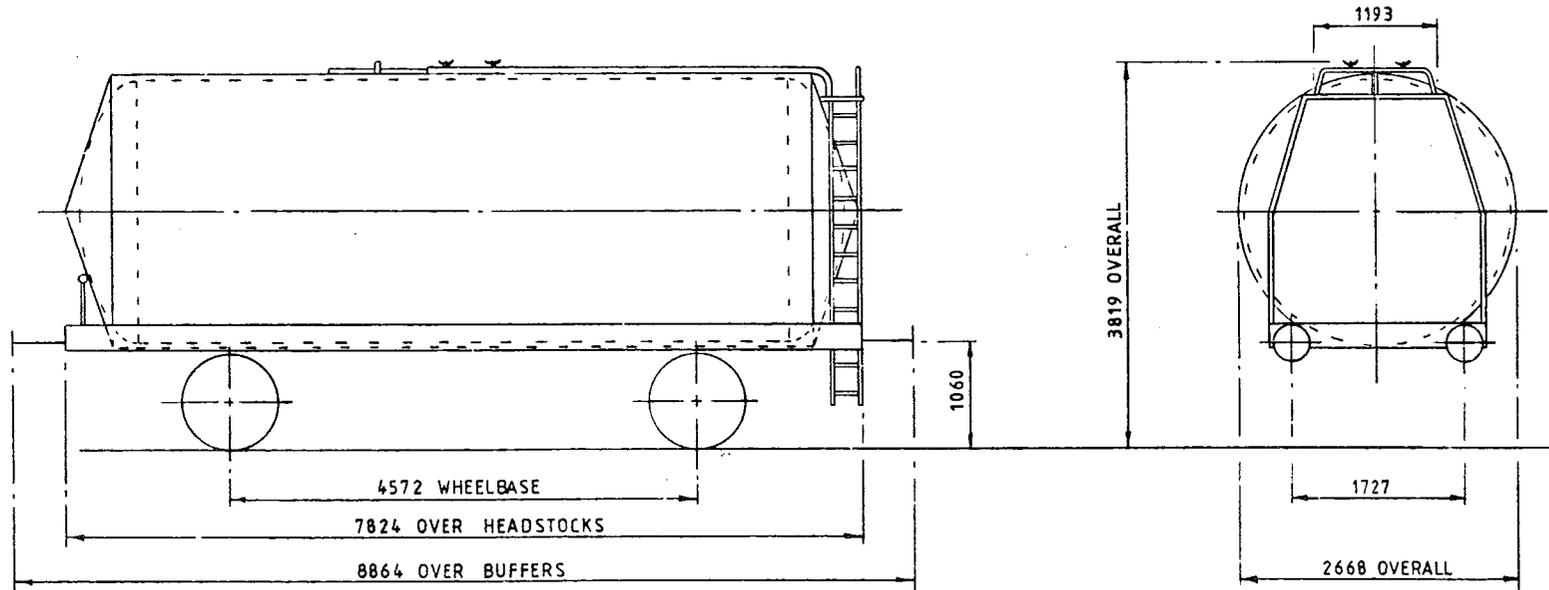

TARE-	13,800 Kg
CAPACITY, WEIGHT-	32,200 Kg
CAPACITY, VOLUME-	35,713 litres
MIN. CURVE-	31m
GEN. ARRGT. DRG. NO.-	

BRAKE-	AIR BLOCK & HAND LEVER
SUSPENSION-	DOUBLE LINK & PARABOLIC SPRING
COUPLINGS-	INSTANTER
BUFFERS-	HYDRAULIC 406 DIA HEADS
WHEELS-	952 DIA
JOURNALS-	140 DIA ROLLER BEARINGS

ISSUE 1

46 tonnes G.L.W. TANK WAGON - CLASS B - LAGGED & COILED

TTO60B

EXCESS LENGTH	4	H	M	L	E
tonnes	46	46	14	14	
VP	0	0	0	0	
AB	22	22	9	9	
RA	8	8	1	1	
MAX. SPEED	60	60	60	60	

TOPS CODE								
CARKND	AARKND			OPERATING PANEL No				
T	T	B	T	T	B	A	1	5
8	9							

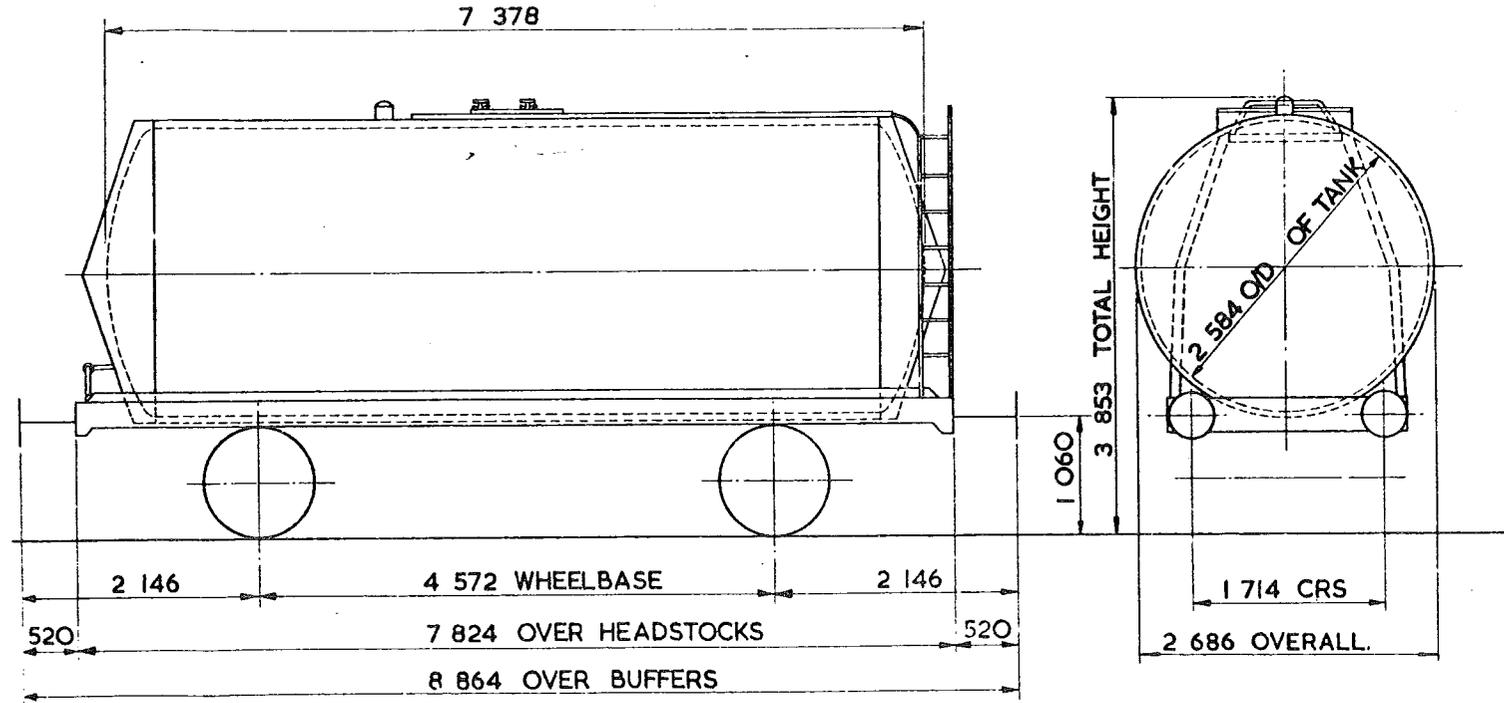

TAPE - 14 100 kg
CARRYING CAPACITY - 31 900 kg
CAPACITY - 36 118 litres.
MAX SPEED - 60 mile/h
WHEELS - 952 DIA.
JOURNALS - 140 DIA. ROLLER BEARINGS

BUFFERS - HYDRAULIC 406 DIA. HEADS.
COUPLINGS - INSTANTER
MIN. CURVE - 31 m
GEN. ARRGT. DRG. No. -
BRAKE - AIR BLOCK, VACUUM PIPED & HAND LEVER.
SUSPENSION - FAT 26

BUILDER - R.Y. PICKERING
OWNER - SUKO
REGISTERED BY - C.M. & E.E. (B.R.B.) DERBY
YEAR BUILT - 1966 - 67
REGISTRATION Nos. - SUKO 65900 - 65903
OWNERS Nos. -

ISSUE 1.
EX. P.O. DIAGRAM 6/185

46 tonnes G.L.W. TANK WAGON CLASS B

TT 060F

EXCESS LENGTH	4	H	M	L	E
tonnes	46	46	14	14	
VB					
AB	22	22	9	9	
RA	8	8	1	1	
MAX SPEED	60	60	60	60	

TOPS CODE										
CARKND		AARKND			OPERATIONAL PANEL N					
T	T	A	T	T	A	A	1	5	8	8

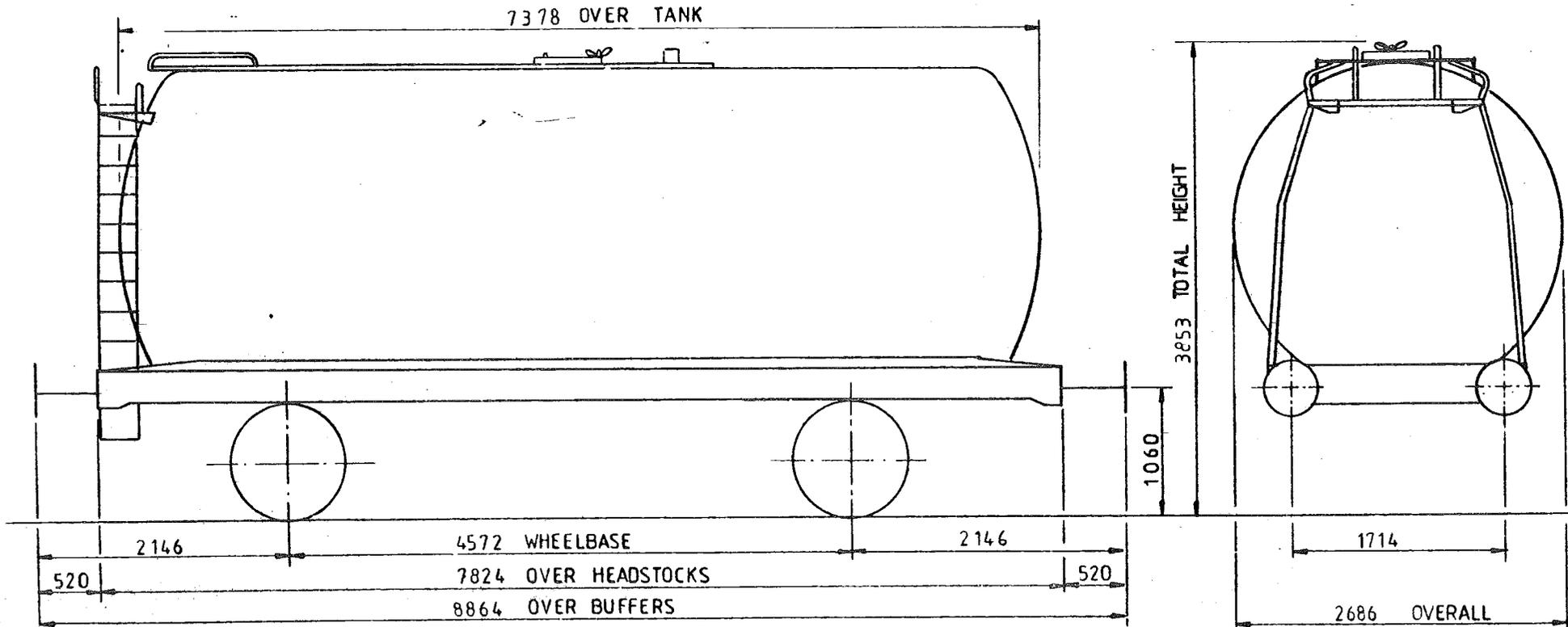

TARE	14 100 kg
CARRYING CAPACITY	31 900 kg
CAPACITY	36118 Litres
MAX SPEED	60 mile/h
WHEELS	φ 952
JOURNALS	φ140 ROLLER BEARINGS

BUFFERS	HYDRAULIC φ406 HEADS
COUPLINGS	INSTANTER
MIN CURVE	31 m
GEN ARRGT DRG No	
BRAKE	AIR BLOCK HAND LEVER
SUSPENSION	FAT 26

ISSUE 1

EX PO DIAGRAM 6/185 (ALLOCATED)

46 tonne GLW TANK WAGON - CLASS 'B'

LOT NUMBER	

TOPS INFORMATION						
AARKND	OPERATING	OPERATING SPEED		BRAKE FORCE DATA		EXCESS LENGTH
CARKND	PANEL No.	60 mile/h UP TO	46 tonne GLW	9t FORCE UP TO	25 tonne GLW	RA (GLW)
T T B A		mile/h ABOVE		22t FORCE ABOVE		4
						9
						DESIGN SHEET
						W1081
						W1090

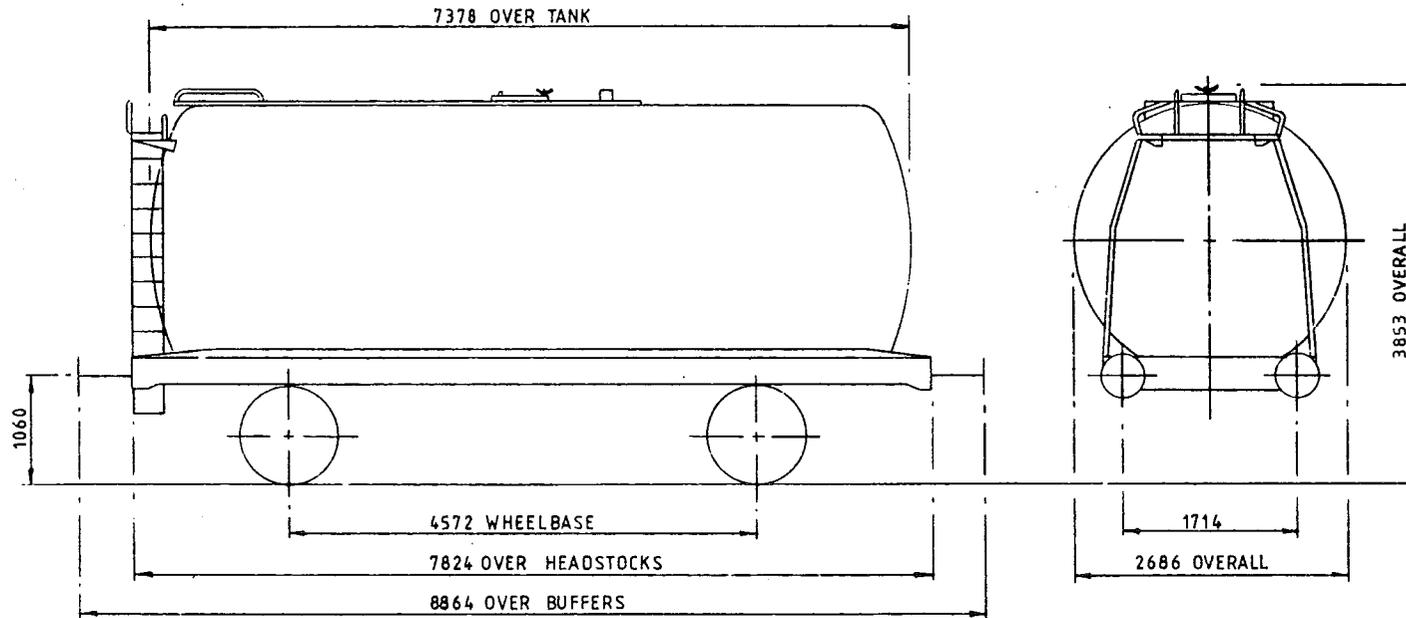

TARE-	13,800 Kg
CAPACITY, WEIGHT-	32,200 Kg
CAPACITY, VOLUME-	36.118 litres
MIN. CURVE-	31m
GEN. ARRGT. DRG. NO.-	

BRAKE-	AIR BLOCK, VAC. PIPE, HAND LEVER
SUSPENSION-	SINGLE LINK & PARABOLIC SPRING
COUPLINGS-	IN STANTER
BUFFERS-	HYDRAULIC 406 DIA HEADS
WHEELS-	952 DIA
JOURNALS-	140 DIA ROLLER BEARINGS

ISSUE I

41 tonnes G.L.W. TANK WAGON BITUMEN

TT 061B

DESIGN SHEET No. W548

EXCESS LENGTH	L	H	M	L	E
tonnes	41	41	16	16	
VB	20	20	9	9	
AB	0	0	0	0	
RA	8	8	1	1	
MAX SPEED	60	60	45	45	

TOPS CODE										
CARKND		AARKND			OPERATING PANEL No.					
T	T	G	T	T	G	A	1	5	6	3

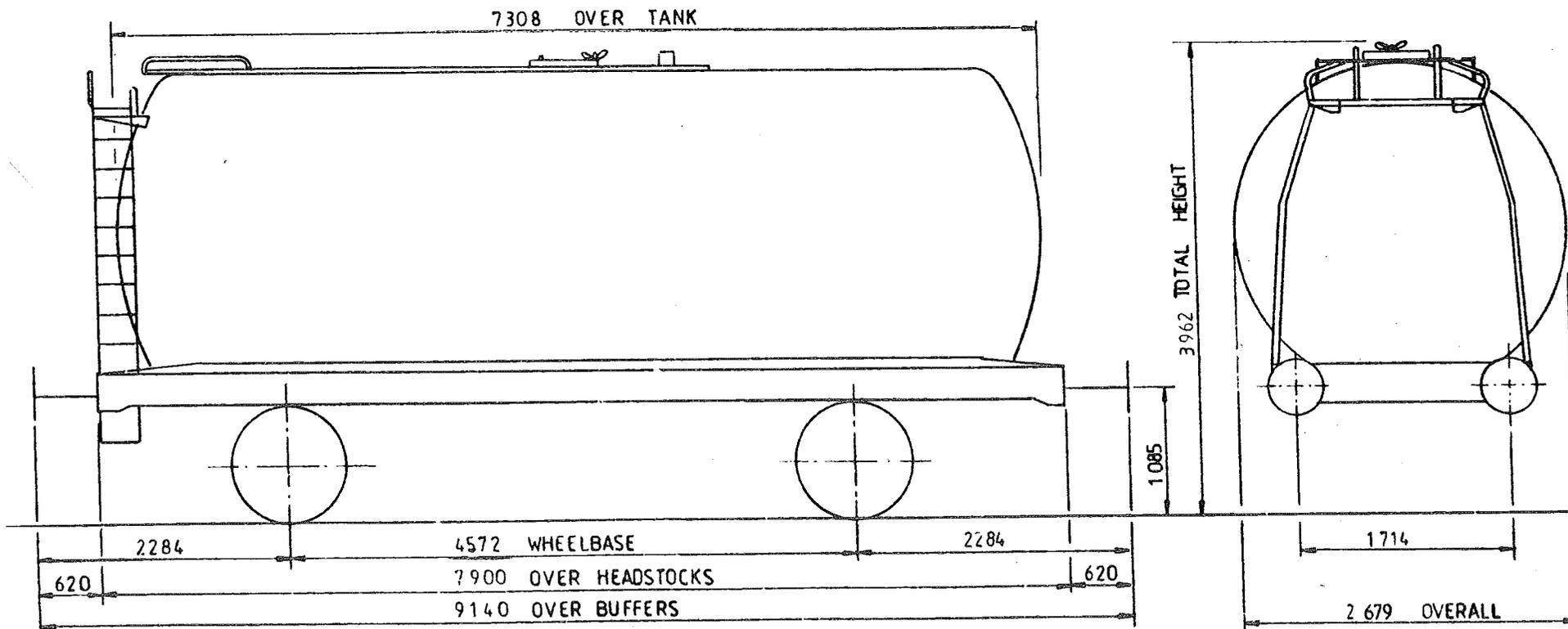

TARE -	15 850 kg
CARRYING CAPACITY -	25 100 kg
CAPACITY -	30 094 litres
MAX SPEED -	60 mile/h
WHEELS -	φ 952
JOURNALS -	φ 140 ROLLER BEARINGS

BUFFERS -	HYDRAULIC φ406 HEADS
COUPLINGS -	INTERNATIONAL SCREW
MIN CURVE -	31 m
GEN ARRGT DRG No. -	
BRAKE -	AFI BLOCK, AIR PIPED & HAND LEVER
SUSPENSION -	EYEBOLT

ISSUE 2.

46 tonnes G.L.W. TANK WAGON-CLASS.B. LAGGED & COILED.

TTO62A

EXCESS LENGTH 5	H	M	L	E
tonnes	46	46	14	14
VB	0	0	0	0
AB	24	24	11	11
RA	8	8	1	1
MAX. SPEED	60	60	60	60

TOPS CODE									
CARKND			AARKND			OPERATING PANEL No			
T	T	B	T	B	A	1	0	3	9

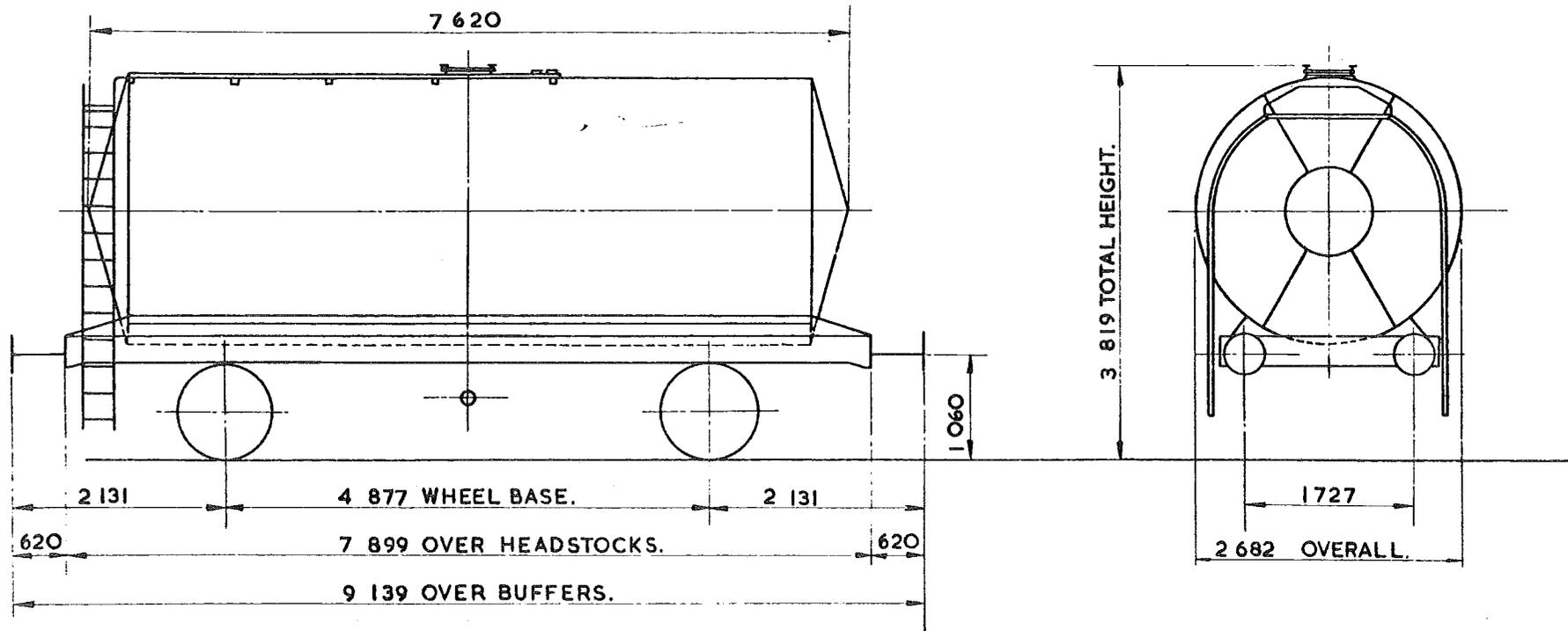

TARE -	14200 kg.
CARRYING CAPACITY -	31800 kg.
CAPACITY -	36232 litres.
MAX. SPEED -	60 mile/h.
WHEELS -	952 DIA.
JOURNALS -	140 DIA. ROLLER BEARINGS.

BUFFERS -	HYDRAULIC 406 DIA. HEADS
COUPLINGS -	INTERNATIONAL SCREW.
MIN. CURVE -	31m.
GEN. ARRGT. DRG. No. -	
BRAKE -	AIR BLOCK, VACUUM PIPED & HAND LEVER.
SUSPENSION -	DOUBLE LINK.

BUILDER -	STANDARD RAILWAY WAGON Co.
OWNER -	B.R.T. AND E. LTD.
REGISTERED BY -	C.M. & E.E. (B. R.B.) DERBY.
YEAR BUILT -	1970.
REGISTRATION Nos. -	57851. TO 57880.
OWNERS Nos. -	10521. TO 10550.

ISSUE 2
EX. P.O. DIAGRAM 6/190.

46 tonnes G.L.W. TANK WAGON

TTO63A

EXCESS LENGTH	4	H	M	L	E
tonnes.	46	46	17	17	
VB	0	0	0	0	
AB	23	23	8	8	
RA	8	8	1	1	
MAX SPEED	60	60	45	45	

TOPS CODE		
CARKND	AARKND	OPERATING PANEL No
T	T	B
T	T	B
A	1	5
3	5	

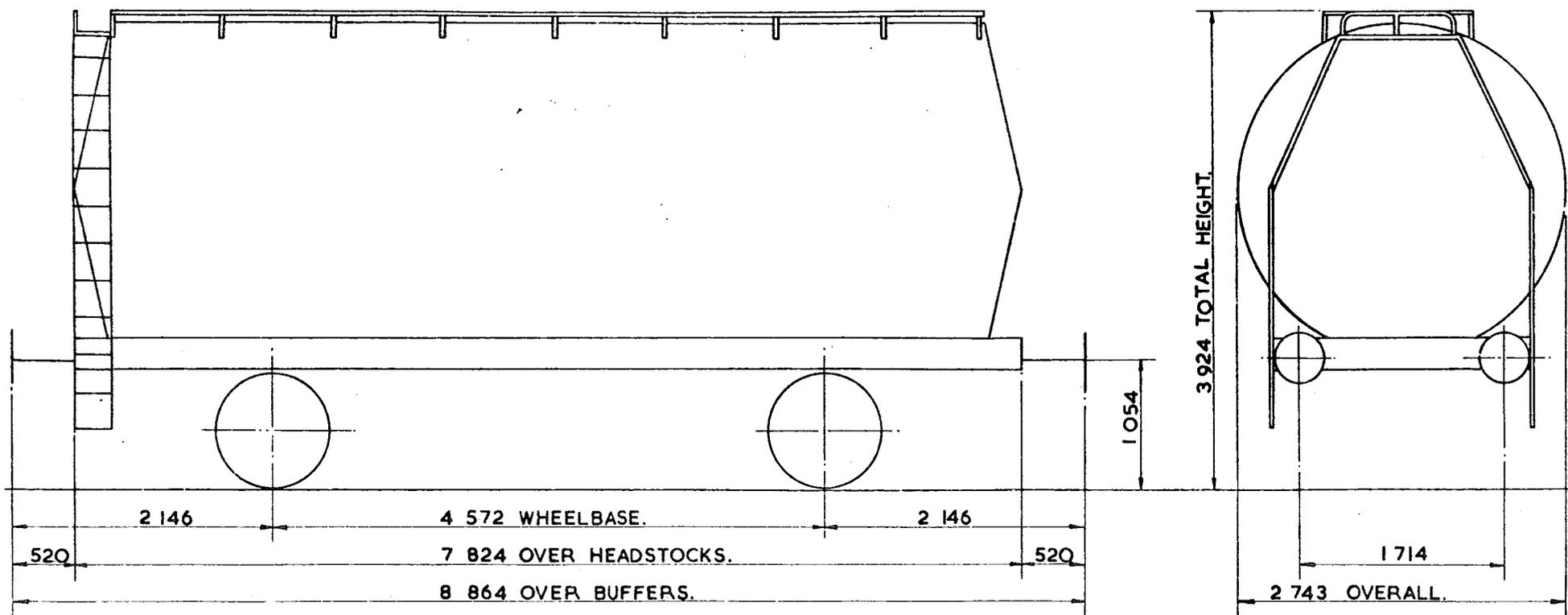

TARE - 16300kg.
CARRYING CAPACITY - 29700kg.
CAPACITY - 31722 litres.
MAX SPEED 60 mile/h.
WHEELS 952 DIA.
JOURNALS - 140 DIA. ROLLER BEARINGS.

BUFFERS - HYDRAULIC 406 DIA. HEADS.
COUPLINGS - INSTANTER
MIN. CURVE - 31m.
GEN ARRGT DRG No. -
BRAKE - AIR BLOCK, VACUUM PIPED & HAND LEVER.
SUSPENSION - DOUBLE LINK.

BUILDER - METRO CAMELL.
OWNER - SUKO & BPO
REGISTERED BY - C.M. & E.E. (B.R.B) DERBY.
YEAR BUILT - 1966
REGISTRATION Nos. - SUKO 61500 - 61512 (RANGE) BPO 61560 - 61581 (RANGE)
OWNERS Nos. -

ISSUE 2

EX. PO. DIAGRAM 6/732 (ALLOCATED)

46 tonne GLW TANK WAGON

LOT NUMBER	

TOPS INFORMATION										
AARKND	OPERATING			OPERATING SPEED		BRAKE FORCE DATA		EXCESS LENGTH	RA (GLW)	DESIGN SHEET
CARKND	PANEL No.			45 mile/h UP TO	16.3 tonne GLW	8 t FORCE UP TO	31 tonne GLW	4	9	W1249
T T A A				60 mile/h ABOVE		23 t FORCE ABOVE				

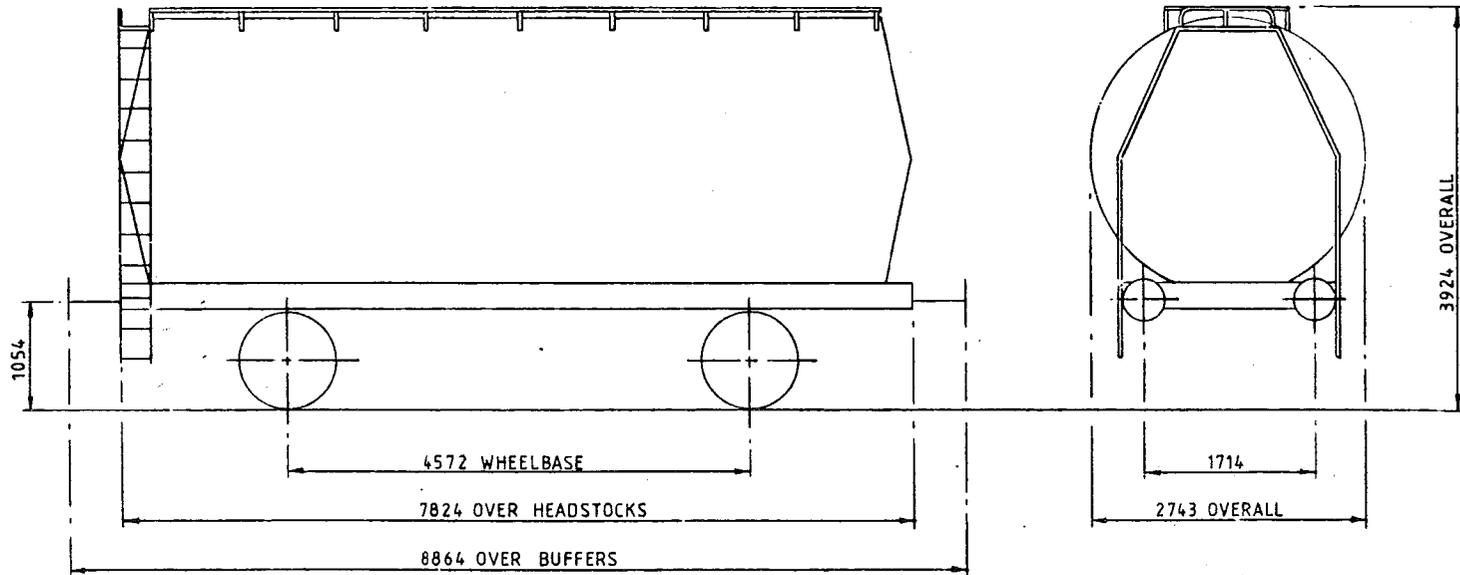

TARE-	16.300 Kg
CAPACITY, WEIGHT-	29.700 Kg
CAPACITY, VOLUME-	31.722 litres
MIN. CURVE-	31m
GEN. ARRGT. DRG. NO.-	

BRAKE-	AIR BLOCK & HAND LEVER
SUSPENSION-	DOUBLE LINK
COUPLINGS-	INSTANTER
BUFFERS-	HYDRAULIC 406 DIA HEADS
WHEELS-	952 DIA
JOURNALS-	140 DIA ROLLER BEARINGS

ISSUE 1

46 tonne GLW TANK WAGON-BITUMEN

LOT NUMBER	

TOPS INFORMATION											
AARKND		OPERATING		OPERATING SPEED			BRAKE FORCE DATA		EXCESS LENGTH	RA (GLW)	DESIGN SHEET
CARKND		PANEL No.		60 mile/h UP TO 46 tonne GLW			8 t FORCE UP TO 31 tonne GLW				
T	T	A	A						4	9	W1174

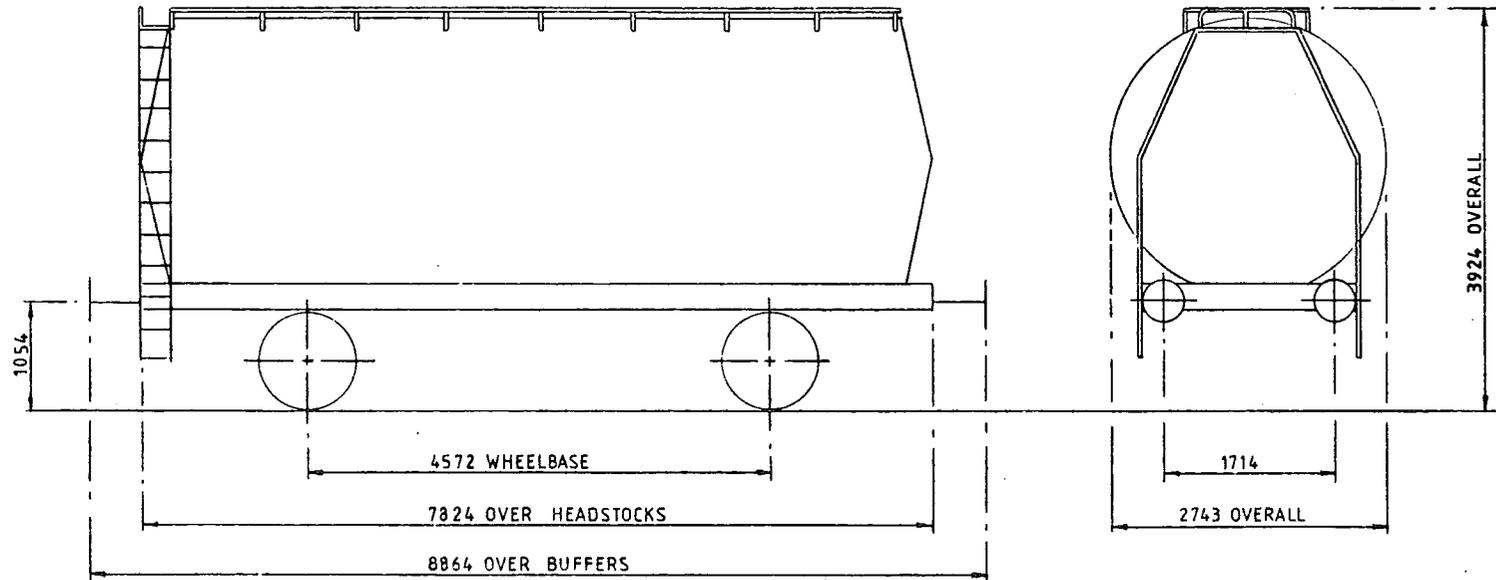

TARE-	15.700 Kg
CAPACITY, WEIGHT-	30 ³⁰⁰ Kg
CAPACITY, VOLUME-	31.722 litres
MIN. CURVE-	31 m
GEN. ARRGT. DRG. NO.-	

BRAKE-	AIR BLOCK & HAND LEVER
SUSPENSION-	SINGLE LINK & PARABOLIC SPRING
COUPLINGS-	INSTANTER
BUFFERS-	HYDRAULIC 406 DIA HEADS
WHEELS-	952 DIA
JOURNALS-	140 DIA ROLLER BEARINGS

ISSUE I

46 tonnes G.L.W. TANK WAGON LAGGED & COILED

TTO64B

EXCESS LENGTH	5	H	M	L	E
tonnes	46	46	13	13	
VB					
AB	22	22	8	8	
RA	8	8	1	1	
MAX. SPEED	60	60	60	60	

TOPS CODE		
CARKND	AARKND	OPERATING PANEL No
T T	A T T A A	I S 7 I

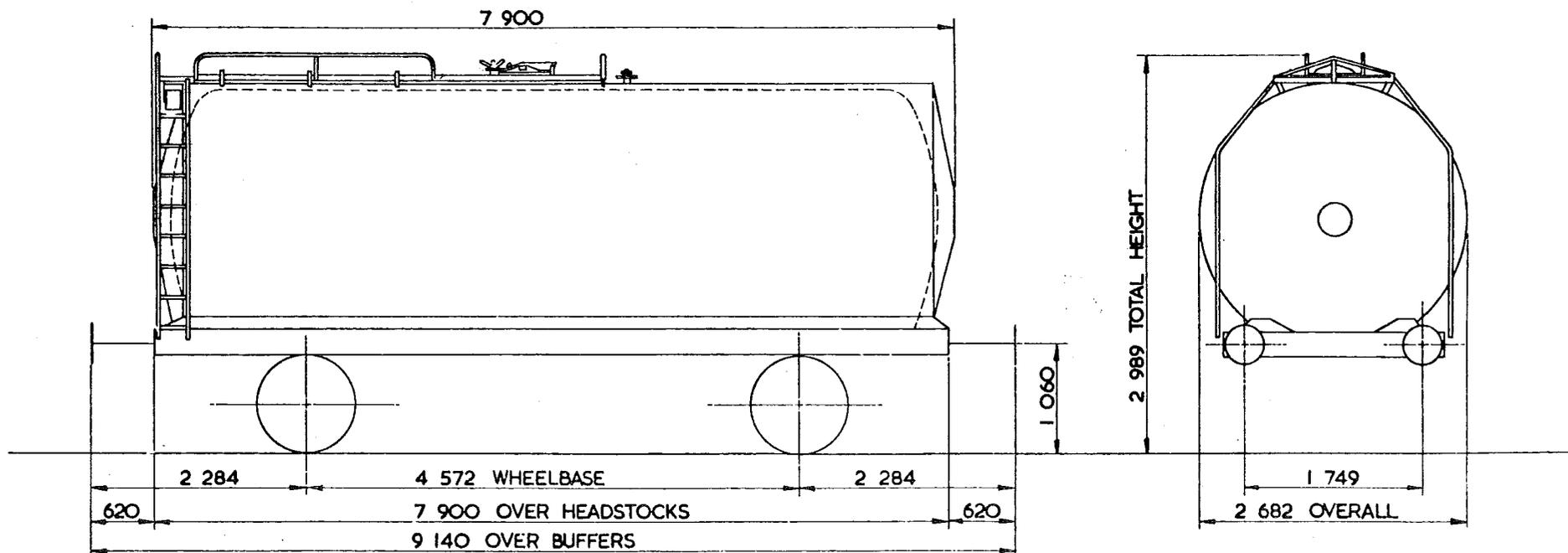

TARE -	12500 kg
CARRYING CAPACITY -	33500 kg
CAPACITY -	34600 litres
MAX. SPEED -	60 mile/h
WHEELS -	952 DIA
JOURNALS -	140 DIA ROLLER BEARINGS

BUFFERS -	SELF CONTAINED 400 DIA HEADS
COUPLINGS -	INTERNATIONAL SCREW
MIN. CURVE -	31 m
GEN. ARRGT DRG. No. -	
BRAKE -	AIR BLOCK & HAND LEVER.
SUSPENSION -	FAT 26

BUILDER -	C.F.P.M. FRANCE
OWNER -	E.G. STEELE
REGISTERED BY -	C.M. & E.E. (B.R.B.) DERBY.
YEAR BUILT -	1968
REGISTRATION Nos. -	55056 - 55078
OWNERS Nos. -	3056 - 3078

ISSUE 1
EX. PO. DIAGRAM. 6/143.

46 tonnes G.L.W TANK WAGON

TTO65A

EXCESS LENGTH	4	H	M	L	E
tonnes	46	46	16	16	
VB					
AB	21	19	9	9	
RA	8	8	1	1	
MAX. SPEED	60	60	60	60	

TOPS CODE										
CARKND		AARKND		OPERATING PANEL No.						
T	T	A	T	T	A	A	1	5	4	3

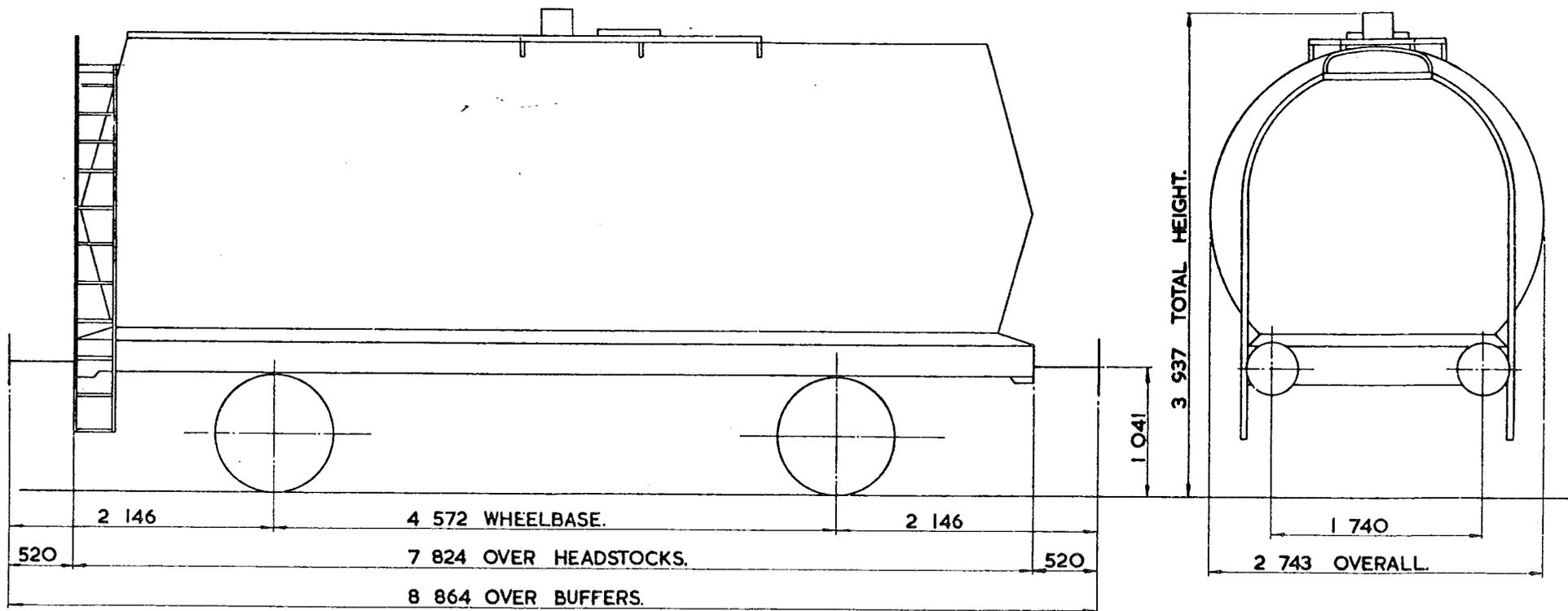

TARE - 15 250 kg
CARRYING CAPACITY - 30 700 kg
CAPACITY - 35 459 litres.
MAX. SPEED - 60 mile/h.
WHEELS - 952 DIA.
JOURNALS - 140 DIA. ROLLER BEARINGS.

BUFFERS - HYDRAULIC 406 DIA HEADS.
COUPLINGS - INSTANTER.
MIN. CURVE - 31 m.
GEN. ARRGT. DRG. No. -
BRAKE - AIR BLOCK & HAND LEVER.
SUSPENSION - DOUBLE LINK.

BUILDER - CHARLES ROBERTS.
OWNER - TIGER LEASING LTD
REGISTERED BY - C.M. & E.E. (B.R.B) DERBY.
YEAR BUILT - 1967.
REGISTRATION Nos. - 51724 - 51763.
OWNERS Nos. - A 724 - A 763.

ISSUE 2

EX. P.O. DIAGRAM 6/767 (ALLOCATED.)

46 tonnes G.L.W TANK WAGON-CLASS B-LAGGED & COILED.

TTO66B

EXCESS LENGTH	4	H	M	L	E
tonnes	46	46	15	15	
VB	20	20	8	8	
AP					
RA	8	8	1	1	
MAX SPEED	60	60	45	45	

TOPS CODE	
CARKND	AARKND
T T F T T F A I 4 9 4	

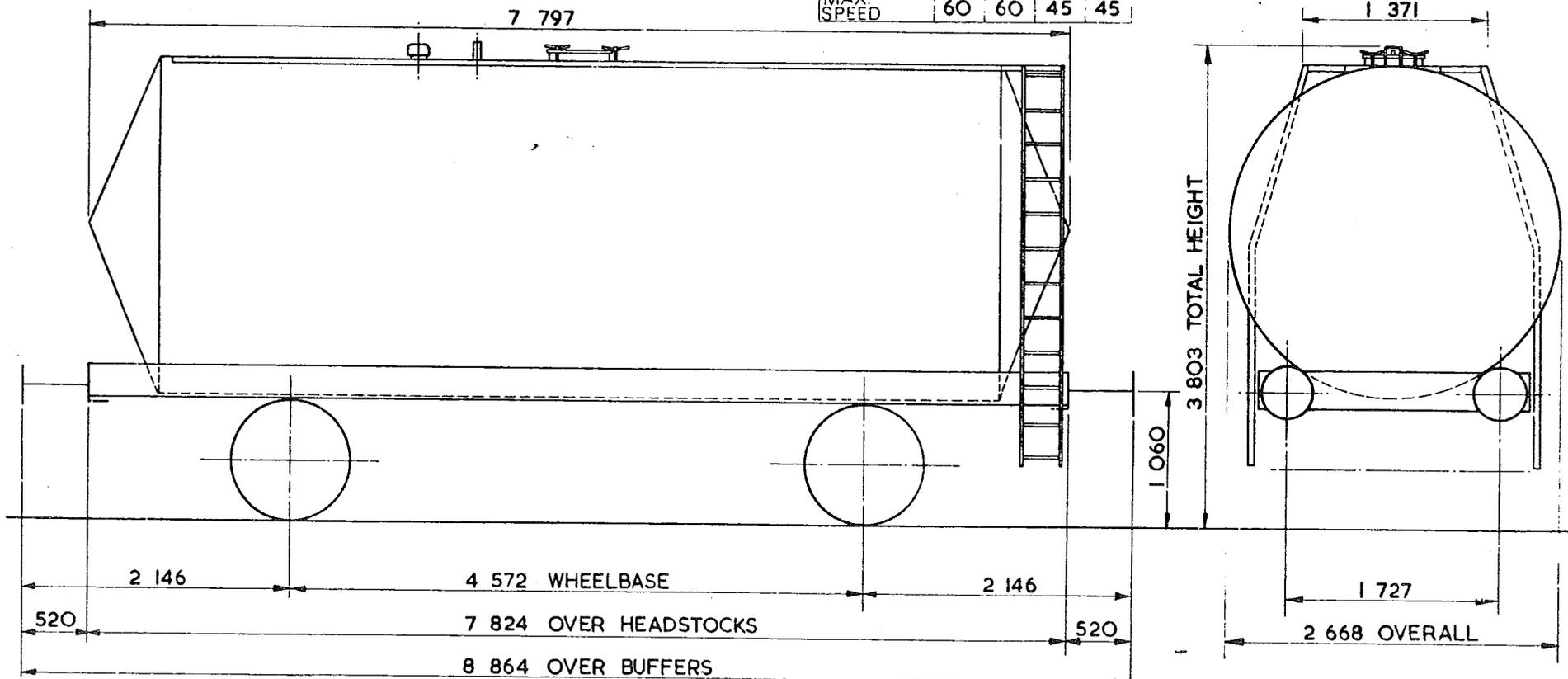

TARE -	14550kg
CARRYING CAPACITY -	31400kg
CAPACITY -	34718 litres
MAX. SPEED -	60 mile/h
WHEELS -	952 DIA.
JOURNALS -	140 DIA. ROLLER BEARINGS

BUFFERS -	HYDRAULIC 406 DIA. HEADS
COUPLINGS -	INSTANTER
MIN. CURVE -	31m
GEN. ARRGT. DRG No. -	
BRAKE -	VACUUM BLOCK & HAND LEVER
SUSPENSION -	DOUBLE LINK

BUILDER -	POWELL DUFFRYN
OWNER -	SUKO & BPO
REGISTERED BY -	CM.&E.E. (B.R.B.) DERBY
YEAR BUILT -	1965
REGISTRATION No. -	SUKO 64123-64723[RANGE] BPO 64177-64762[RANGE]
OWNERS Nos. -	

ISSUE 2

EX. P.O. DIAGRAM 6/727 (ALLOCATED.)

46 tonnes G.L.W. TANK WAGON - CLASS B - LAGGED AND COILED

TTO66C

EXCESS LENGTH	4	H	M	L	E
tonnes	46	46	15	15	
VB	19	19	8	8	
AB					
RA	8	8	1	1	
MAX SPEED	60	60	45	45	

TOPS CODE										
CARKND		AARKND			OPERATING PANEL No					
T	T	F	T	T	F	A	1	4	9	0

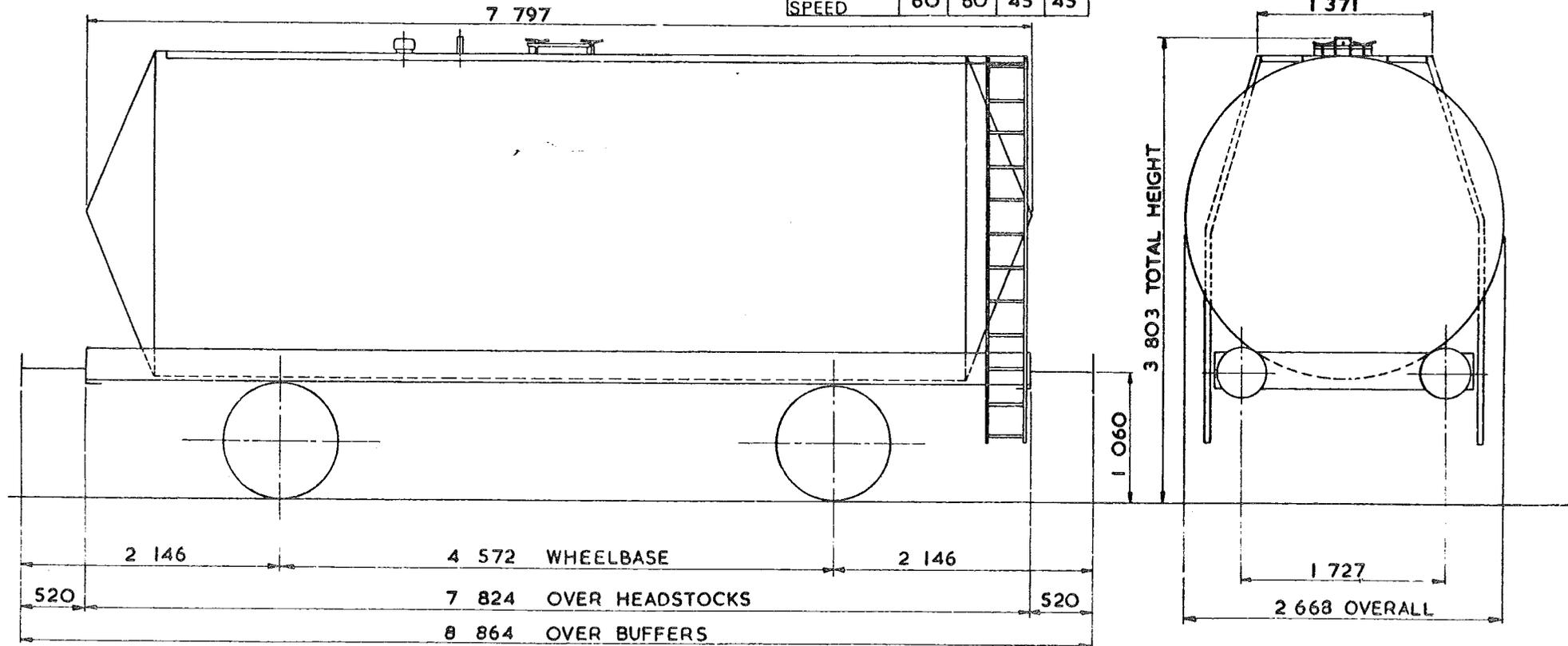

TARE -	15,050 kg
CARRYING CAPACITY -	30,900 kg
CAPACITY -	34,718 litres
MAX. SPEED -	60 mile/h
WHEELS -	952 DIA.
JOURNALS -	140 DIA. ROLLER BEARING

BUFFERS -	HYDRAULIC 406 DIA HEADS
COUPLINGS -	INSTANTER
MIN. CURVE -	31 m
GEN. ARRGT. DRG. No. -	
BRAKE -	VACUUM BLOCK & HAND LEVER
SUSPENSION -	DOUBLE LINK

46 tonnes G.L.W. TANK WAGON - CLASS B - LAGGED AND COILED

TTO66D

EXCESS LENGTH	4	H	M	L	E
tonnes	46	45	15	15	
VP	17	17	7	7	
AD					
RA	8	8	1	1	
MAX SPEED	60	60	45	45	

TOPS CODE									
CARKND					AARKND				
T	T	F	T	F	A	I	4	9	5

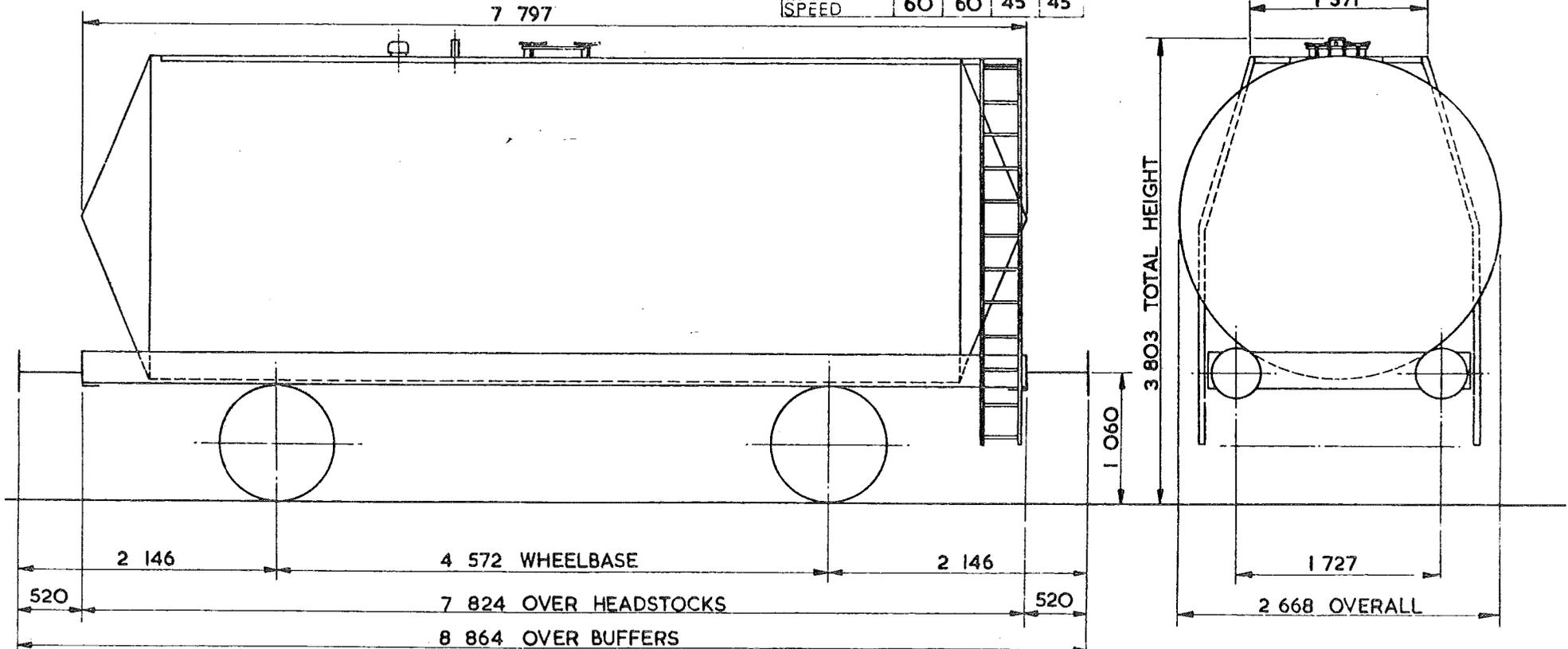

TARE -	15 050 kg
CARRYING CAPACITY -	30 900 kg
CAPACITY -	34 718 litres
MAX SPEED -	60 mile/h
WHEELS -	952 DIA.
JOURNALS -	140 DIA. ROLLER BEARINGS

BUFFERS -	HYDRAULIC 406 DIA. HEADS
COUPLINGS -	INSTANTER
MIN. CURV	31m
GEN. ARRGT. DRG. No. -	
BRAKE -	VACUUM BLOCK & HAND LEVER
SUSPENSION -	DOUBLE LINK

BUILDER -	METRO CAMMELL
OWNER -	SUKO & BPO
REGISTERED BY -	C.M. & E.E. (B.R.B.) DERBY
YEAR BUILT -	1964/65
REGISTRATION Nos. -	SUKO 64321 TO 64540 (RANGE) BPO 64370 TO 64696 (RANGE)
OWNERS Nos. -	

ISSUE 2
EX. P.O. DIAGRAM 6/184

46 tonnes G.L.W. TANK WAGON - CLASS 'B'

TTO66E

EXCESS LENGTH	4	H	M	L	E
tonnes	46	46	16	16	
VB	21	19	9	9	
AB					
RA	8	8	1	1	
MAX. SPEED	60	60	45	45	

TOPS CODE										
CARKND		AARKND			OPERATING PANEL No					
T	T	F	T	T	F	A	1	5	3	1

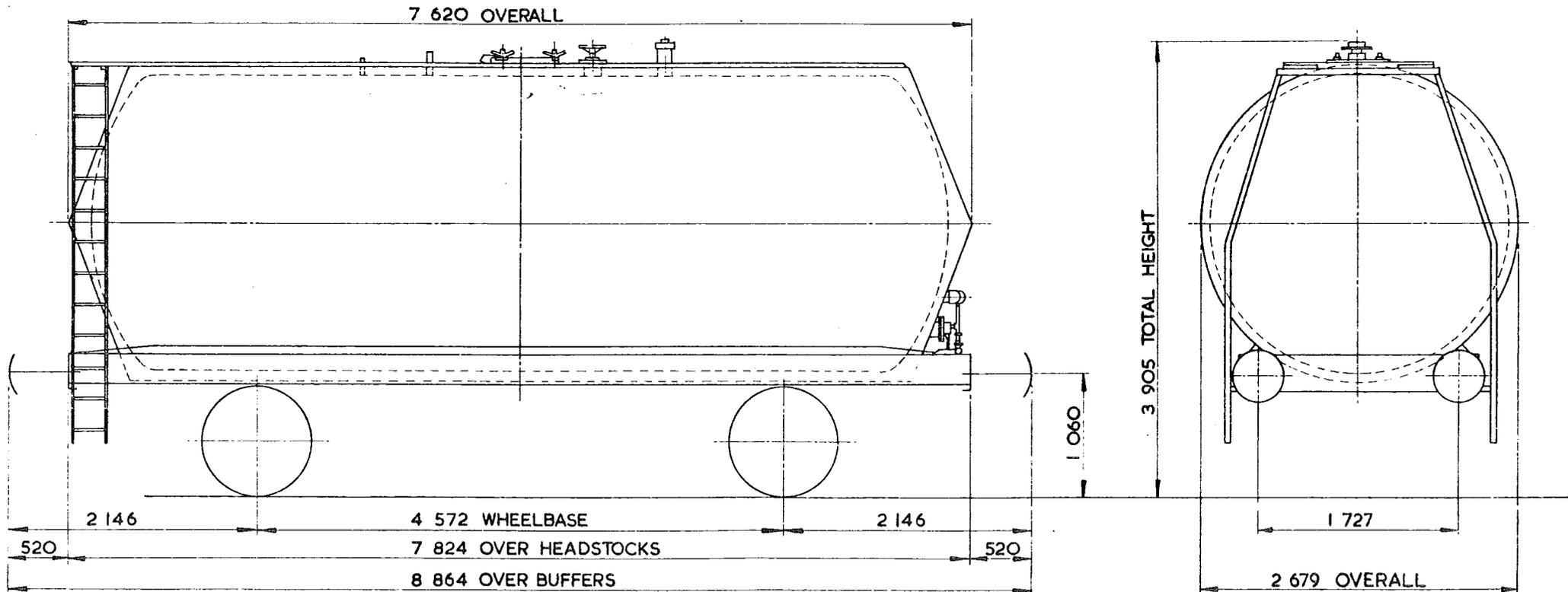

RE - 15 ⁸⁰⁰ kg
CARRYING CAPACITY - 30 ²⁰⁰ kg
CAPACITY - 35 ³⁶⁷ litres
MAX SPEED - 60 mile/h
WHEELS - 952 DIA
JOURNALS - 140 DIA ROLLER BEARINGS

BUFFERS - HYDRAULIC 406 DIA HEADS
COUPLINGS - INSTANTER
MIN. CURVE 31 m
GEN. ARRGT. DRG. No. -
BRAKE - VACUUM BLOCK & HAND LEVER
SUSPENSION - DOUBLE LINK

BUILDER - METRO CAMELL
OWNER - BRITISH RAILWAY TRAFFIC & ELECTRIC
REGISTERED BY - C.M. & E.E.(B.R.B) DERBY
YEAR BUILT - 1965
REGISTRATION Nos. - 57086 & 57087
OWNERS Nos. - 5652 & 5653

ISSUE 2

46 tonnes G.L.W. TANK WAGON-BITUMEN

TTO66F

EXCESS LENGTH	4	H	M	L	E
tonnes	46	46	17	17	
VB	0	0	0	0	
AB	26	26	8	8	
RA	8	8	1	1	
MAX. SPEED	60	60	45	45	

TOPS CODE										
CARKND		AARKND			OPERATING PANEL No.					
T	T	B	T	T	B	A	1	3	2	4

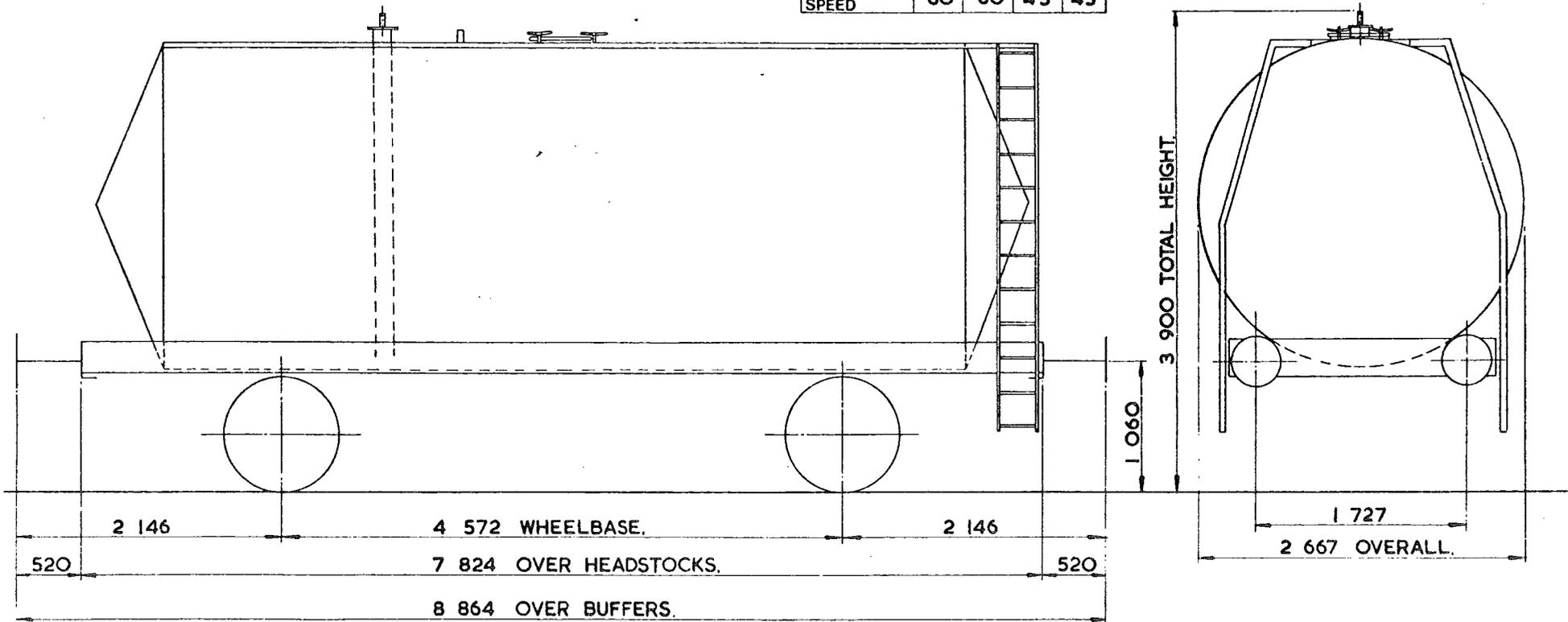

TARE-	16500kg.
CARRYING CAPACITY-	29500kg.
CAPACITY-	31367litres.
MAX. SPEED-	60 mile/h.
WHEELS-	952 DIA.
JOURNALS-	140 DIA. ROLLER BEARINGS.

BUFFERS-	HYDRAULIC 406 DIA. HEADS.
COUPLINGS-	INSTANTER.
MIN. CURVE-	31m.
GEN. ARRGT. DRG. No.-	
BRAKE-	AIR BLOCK, VACUUM PIPE & HAND LEVER.
SUSPENSION-	DOUBLE LINK.

BUILDER-	METRO-CAMMELL.
OWNER-	SUKO
REGISTERED BY-	C.M. & E.E. (B.R.B.) DERBY.
YEAR BUILT-	1965.
REGISTRATION Nos.-	SUKO 61107.
OWNERS Nos.-	

ISSUE 1
EX. P.O. DIAGRAM 6/540.

46 tonnes G.L.W. TANK WAGON BITUMEN

TT 066G

EXCESS LENGTH	4	H	M	L	E
tonnes	46	46	17	17	
VB					
AB	17	17	7	7	
RA	8	8	1	1	
MAX SPEED	60	60	45	45	

TOPS CODE										
CARKND		AARKND			OPERATING PANEL N					
T	T	A	T	T	A	A	1	5	3	0

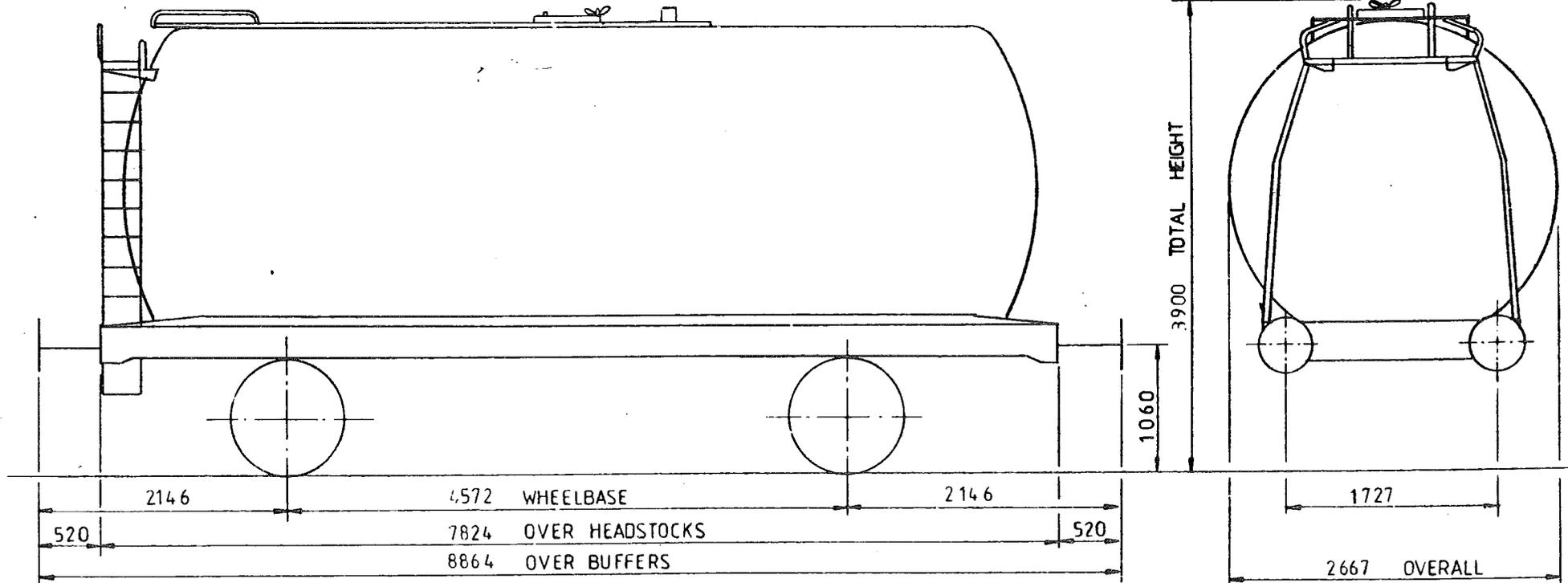

TARE	16 500 kg
CARRYING CAPACITY	29 500 kg
CAPACITY	31367 Litres
MAX SPEED	60 mile/h
WHEELS	φ 952
JOURNALS	φ140 ROLLER BEARINGS

BUFFERS	HYDRAULIC φ406 HEADS
COUPLINGS	INSTANTER
MIN CURVE	31 m
GEN ARRGT DRG No	
BRAKE	AIR BLOCK HAND LEVER
SUSPENSION	DOUBLE LINK

ISSUE 1

EX PO DIAGRAM 6/200(ALLOCATED)

46 tonnes G.L.W. TANK WAGON BITUMEN

TT 066H

EXCESS LENGTH	4	H	M	L	E
tonnes	46	46	17	17	
VB					
AB	24	24	10	10	
RA	8	8	1	1	
MAX SPEED	60	60	45	45	

TOPS CODE					
CARKND	AARKND	OPERATION			
T	T	T	A	A	1 5 2 9

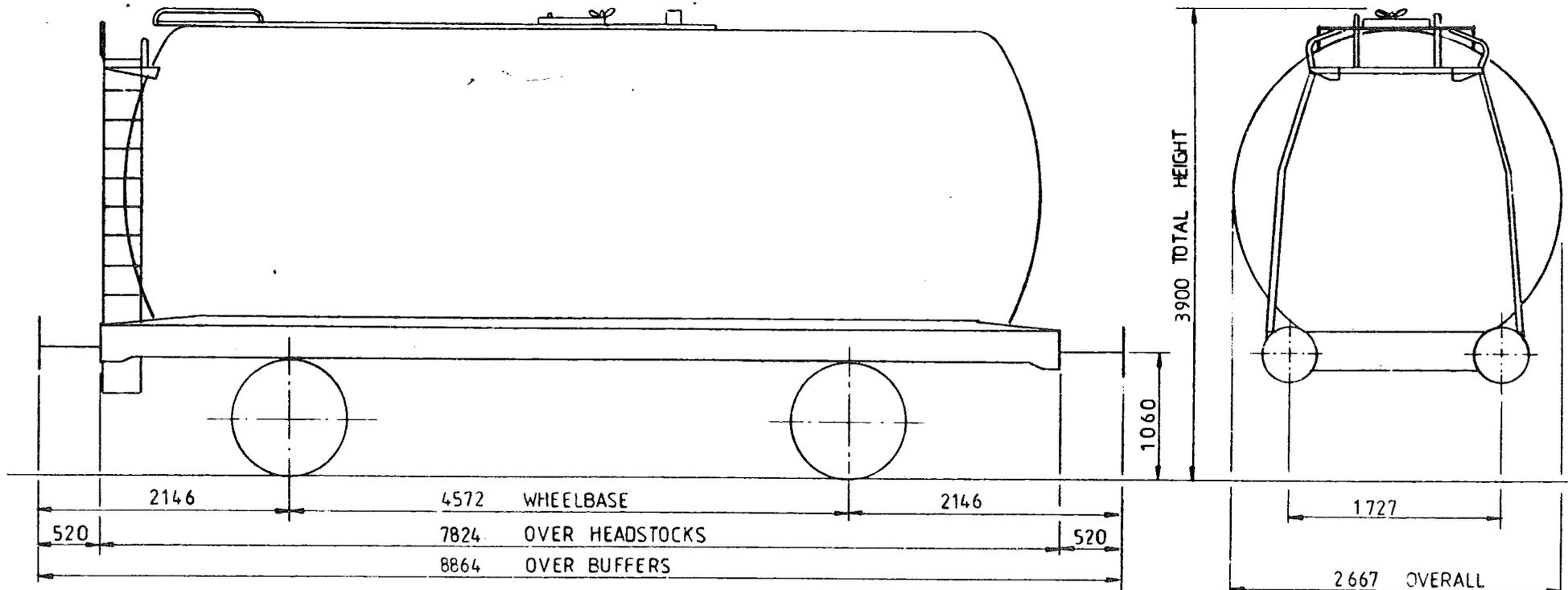

TARE	16500 kg
CARRYING CAPACITY	29500 kg
CAPACITY	31367 Litres
MAX SPEED	60 mile/h
WHEELS	φ 952
JOURNALS	φ140 ROLLER BEARINGS

BUFFERS	HYDRAULIC φ406 HEADS
COUPLINGS	INSTANTER
MIN CURVE	31 m
GEN ARRGT DRG No	
BRAKE	AIR BLOCK HAND LEVER
SUSPENSION	DOUBLE LINK

ISSUE 1

EX PO DIAGRAM 6/200 (ALLOCATED)

46 tonnes G.L.W. TANK WAGON CLASS B

TT 066J

W614

EXCESS LENGTH	4	H	M	L	E
tonnes	46	46	15	15	
VB					
AB	26	26	11	11	
RA	8	8	1	1	
MAX SPEED	60	60	60	60	

TOPS CODE										
CARKND			AARKND			OPERATION PANEL N				
T	T	A	T	T	A	A	8	9	5	3

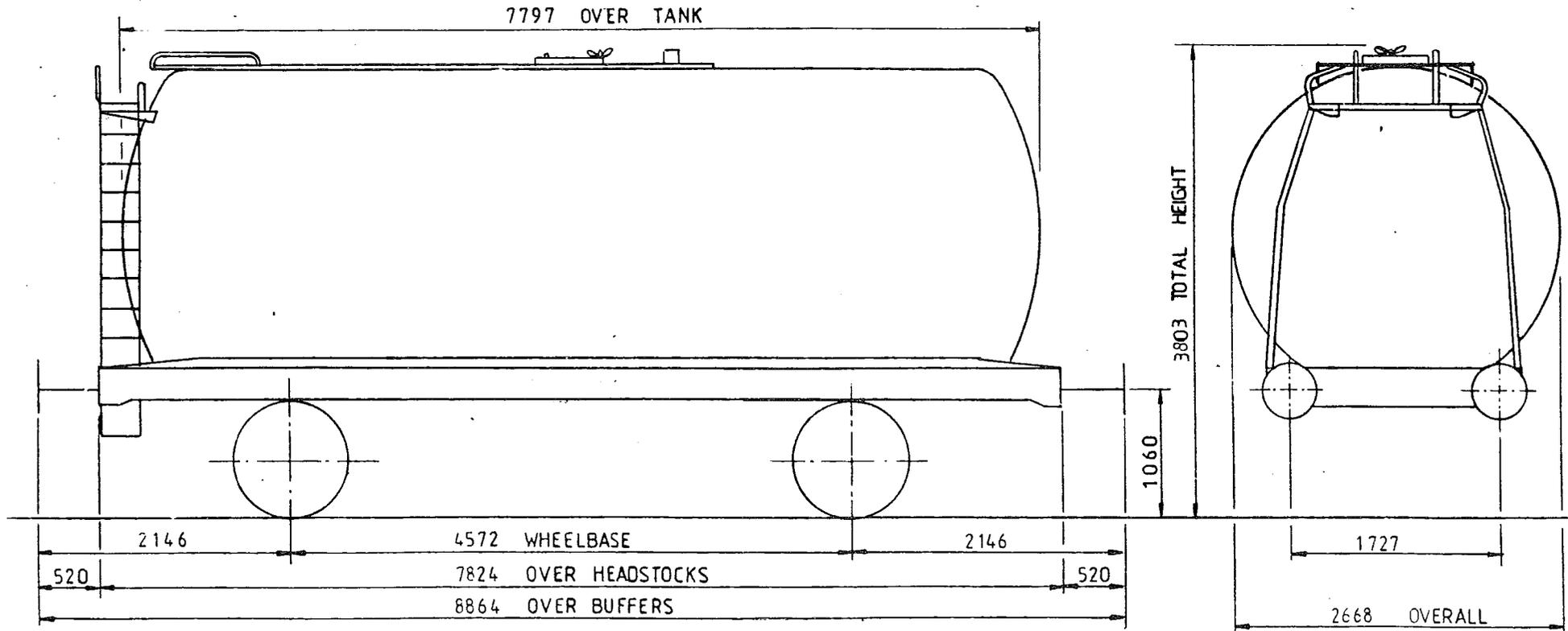

TARE	13150 kg
CARRYING CAPACITY	32500 kg
CAPACITY	34718 Litres
MAX SPEED	60 mile/h
WHEELS	φ 952
JOURNALS	φ140 ROLLER BEARINGS

BUFFERS	HYDRAULIC φ406 HEADS
COUPLINGS	INSTANTER
MIN CURVE	31 m
GEN ARRGT DRG No	
BRAKE	AIR BLOCK HAND LEVER
SUSPENSION	DOUBLE LINK

ISSUE 2

EX PO DIAGRAM 6/184 (ALLOCATED)

46 tonne GLW TANK WAGON CLASS 'B' LAGGED & COILED

LOT NUMBER	

TOPS INFORMATION								
AARKND	OPERATING	OPERATING SPEED		BRAKE FORCE DATA		EXCESS LENGTH	RA (GLW)	DESIGN SHEET
CARKND	PANEL No.	60 mile/h UP TO	46 tonne GLW	5 t FORCE UP TO	30.5 tonne GLW	4	9	W1158
T T A A		mile/h ABOVE		23 t FORCE ABOVE				

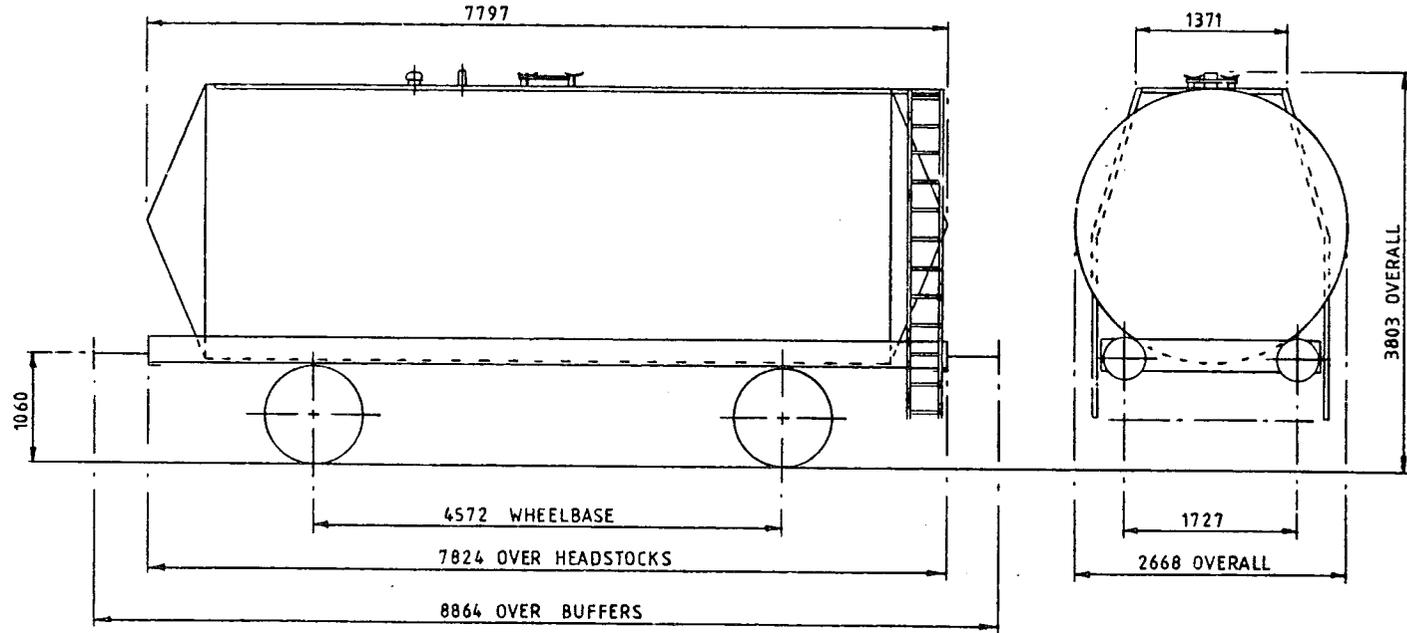

TARE-	15.300 Kg
CAPACITY, WEIGHT-	30.700 Kg
CAPACITY, VOLUME-	34.718 litres
MIN. CURVE-	31m
GEN. ARRG. DRG. NO.-	

BRAKE-	AIR BLOCK & HAND LEVER
SUSPENSION-	DOUBLE LINK & PARABOLIC SPRING
COUPLINGS-	INSTANTER
BUFFERS-	HYDRAULIC 406 DIA HEADS
WHEELS-	952 DIA
JOURNALS-	140 DIA ROLLER BEARINGS

ISSUE 1

46 tonne GLW TANK WAGON - CLASS 'B'

LOT NUMBER	

TOPS INFORMATION						
AARKND	OPERATING	OPERATING SPEED		BRAKE FORCE DATA		EXCESS
CARKND	PANEL No.	60 mile/h UP TO		5t FORCE UP TO		LENGTH
T T A A		mile/h ABOVE		30.5 tonne GLW		4
		46 tonne GLW		23t FORCE ABOVE		9
						W1160

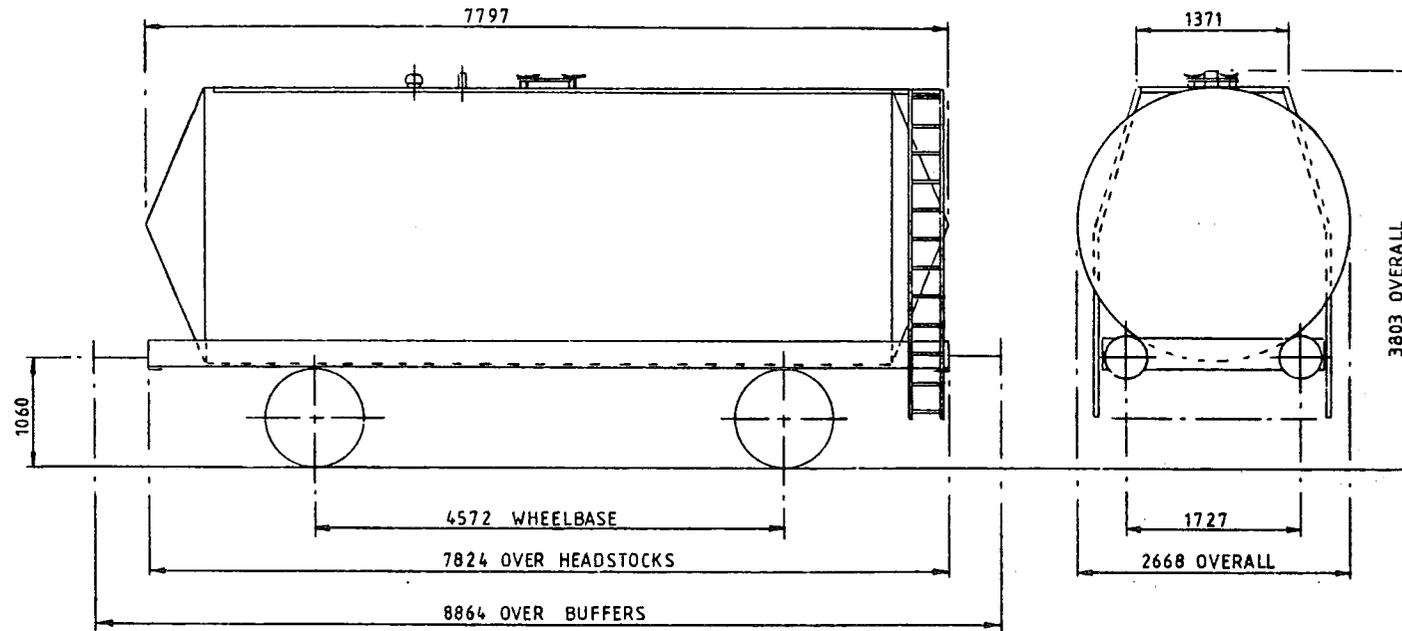

TARE-	14,500 Kg
CAPACITY, WEIGHT-	31,500 Kg
CAPACITY, VOLUME-	34,718 litres
MIN. CURVE-	31m
GEN. ARRGT. DRG. NO.-	

BRAKE-	AIR BLOCK & HAND LEVER
SUSPENSION-	DOUBLE LINK & PARABOLIC SPRING
COUPLINGS-	INSTANTER
BUFFERS-	HYDRAULIC 406 DIA HEADS
WHEELS-	952 DIA
JOURNALS-	140 DIA ROLLER BEARINGS

ISSUE 1

46 tonne GLW TANK WAGON

LOT NUMBER	

TOPS INFORMATION												
AARKND		OPERATING		OPERATING SPEED			BRAKE FORCE DATA			EXCESS LENGTH	RA (GLW)	DESIGN SHEET
CARKND		PANEL No.		60 mile/h UP TO 46 tonne GLW			6t FORCE UP TO 30.5tonneGLW			4	8	W1335
T	T	A	A	mile/h ABOVE			25t FORCE ABOVE					

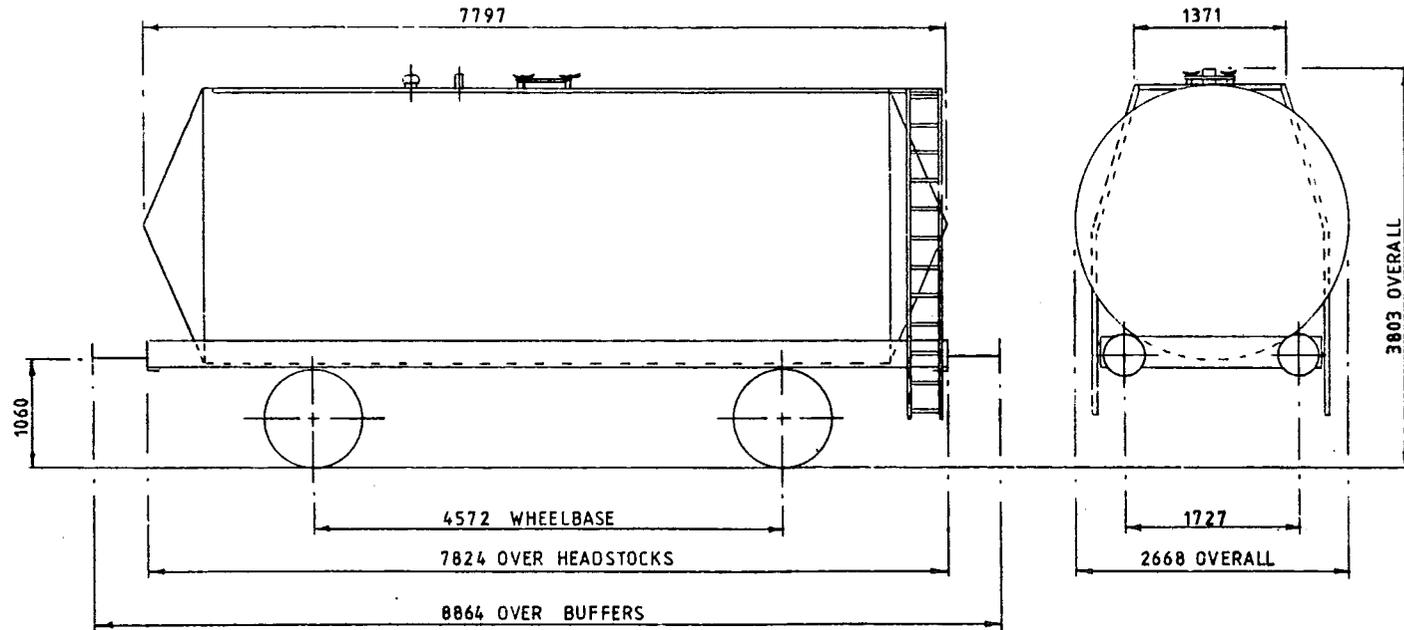

TARE-	14.850 Kg
CAPACITY, WEIGHT-	31.150 Kg
CAPACITY, VOLUME-	34.718 litres
MIN. CURVE-	31m
GEN. ARRGT. DRG. NO.-	

BRAKE-	AIR BLOCK & HAND LEVER
SUSPENSION-	DOUBLE LINK & PARABOLIC SPRING
COUPLINGS-	INSTANTER
BUFFERS-	HYDRAULIC 406 DIA HEADS
WHEELS-	952 DIA
JOURNALS-	140 DIA ROLLER BEARINGS

ISSUE 1

46 tonne GLW TANK WAGON - CLASS 'B' LAGGED & COILED

LOT NUMBER	

TOPS INFORMATION						
AARKND	OPERATING	OPERATING SPEED		BRAKE FORCE DATA		EXCESS LENGTH
CARKND	PANEL No.	60 mile/h UP TO	46 tonne GLW	5t FORCE UP TO	30.5 tonne GLW	RA (GLW)
T T A A		mile/h ABOVE		23t FORCE ABOVE		8
						DESIGN SHEET
						W1337

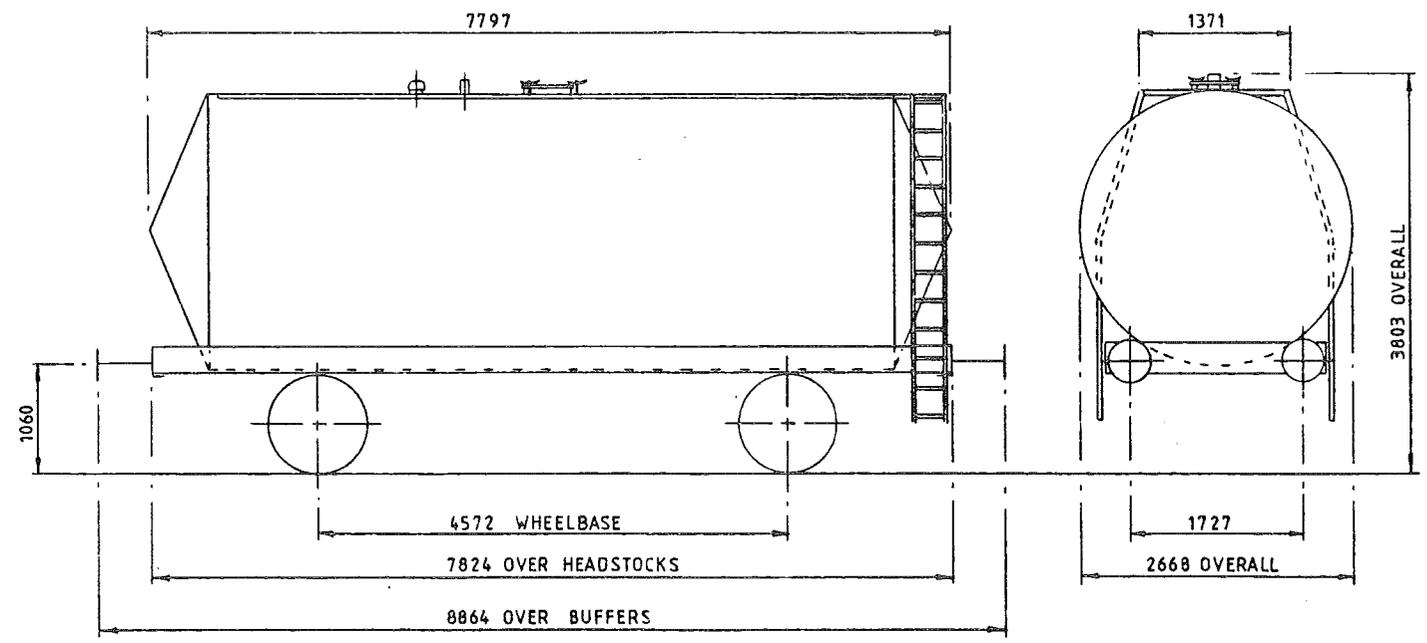

TARE-	13,750 Kg
CAPACITY, WEIGHT-	32,250 Kg
CAPACITY, VOLUME-	34,718 litres
MIN. CURVE-	31 m
GEN. ARRGT. DRG. NO.-	

BRAKE-	AIR BLOCK & HAND LEVER
SUSPENSION-	DOUBLE LINK & PARABOLIC SPRING
COUPLINGS-	INSTANTER
BUFFERS-	HYDRAULIC 406 DIA HEADS
WHEELS-	952 DIA
JOURNALS-	140 DIA ROLLER BEARINGS

ISSUE 1

46 tonne GLW TANK WAGON - CLASS 'B'

LOT NUMBER	

TOPS INFORMATION						
AARKND	OPERATING	OPERATING SPEED		BRAKE FORCE DATA		EXCESS LENGTH
CARKND	PANEL No.	60 mile/h UP TO	46 tonne GLW	5.3t FORCE UP TO	30.5 tonne GLW	RA (GLW)
T T A A		mile/h ABOVE		23.2t FORCE ABOVE		4
						9
						W1403

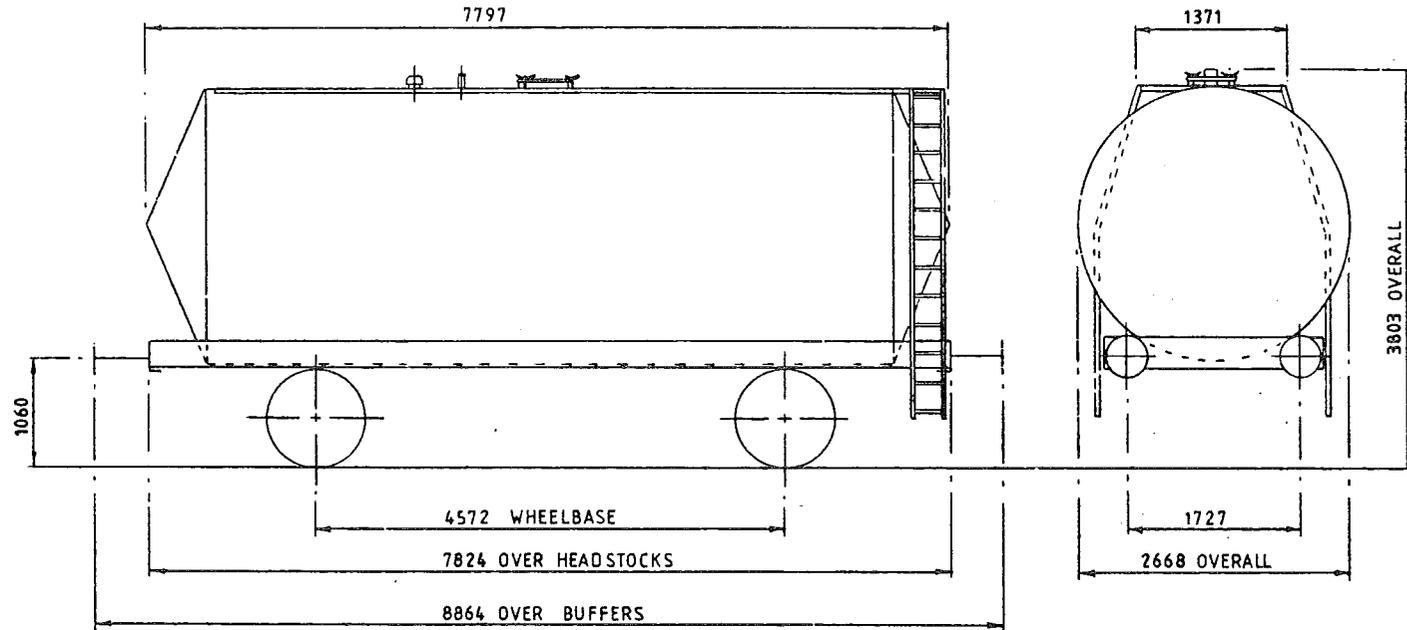

TARE-	14,500 Kg
CAPACITY, WEIGHT-	31,500 Kg
CAPACITY, VOLUME-	34,718 litres
MIN. CURVE-	31 m
GEN. ARRGT. DRG. NO.-	

BRAKE-	AIR BLOCK & HAND LEVER
SUSPENSION-	DOUBLE LINK & PARABOLIC SPRING
COUPLINGS-	INSTANTER
BUFFERS-	HYDRAULIC 406 DIA HEADS
WHEELS-	952 DIA
JOURNALS-	140 DIA ROLLER BEARINGS

ISSUE 1

46 tonne GLW TANK WAGON - CLASS 'B'

LOT NUMBER	

TOPS INFORMATION							
AARKND	OPERATING PANEL No.	OPERATING SPEED		BRAKE FORCE DATA	EXCESS LENGTH	RA (GLW)	DESIGN SHEET
CARKND		60 mile/h UP TO	46 tonne GLW	5.3t FORCE UP TO		9	WI405
T T A A		mile/h ABOVE		23.2t FORCE ABOVE	30.5 tonne GLW		

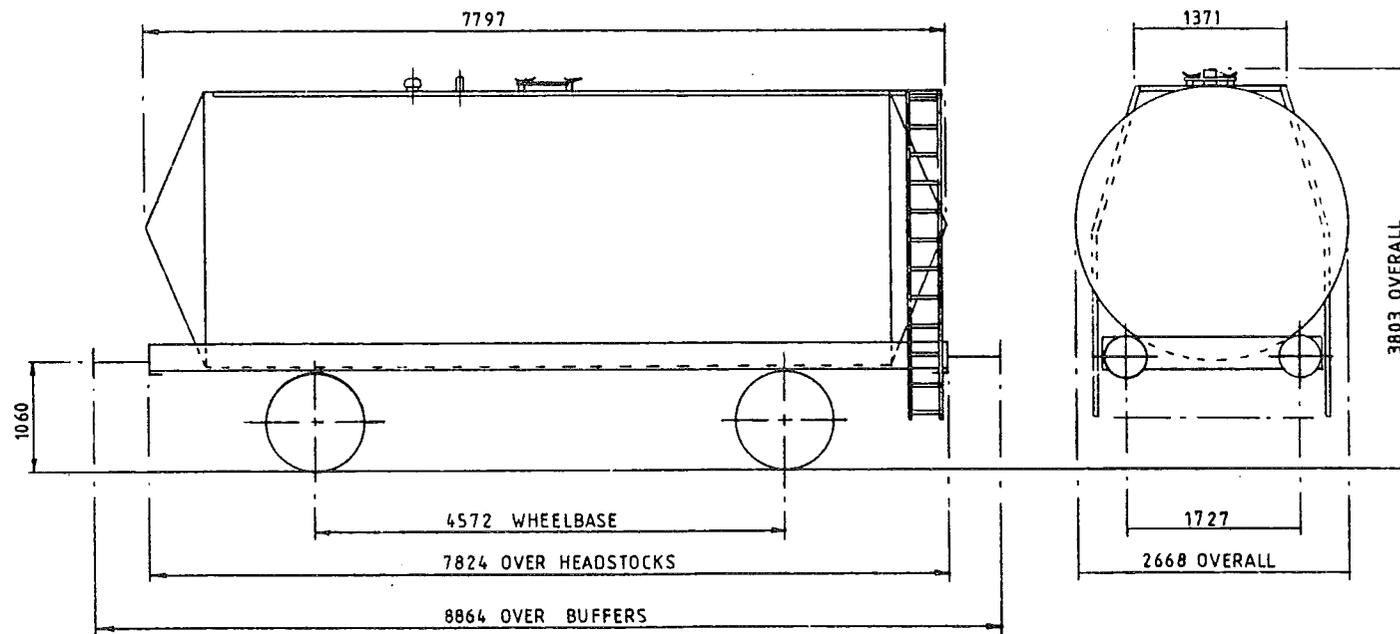

TARE-	14,700 Kg
CAPACITY, WEIGHT-	31,300 Kg
CAPACITY, VOLUME-	34,718 litres
MIN. CURVE-	31 m
GEN. ARRGT. DRG. NO.-	

BRAKE-	AIR BLOCK & HAND LEVER
SUSPENSION-	DOUBLE LINK & PARABOLIC SPRING
COUPLINGS-	INSTANTER
BUFFERS-	HYDRAULIC 406 DIA HEADS
WHEELS-	952 DIA
JOURNALS-	140 DIA ROLLER BEARINGS

ISSUE 1

46 tonne GLW TANK WAGON - CLASS 'B'

LOT NUMBER	

TOPS INFORMATION								
AARKND	OPERATING	OPERATING SPEED		BRAKE FORCE DATA		EXCESS	RA	DESIGN
CARKND	PANEL No.	60 mile/h UP TO	46 tonne GLW	5.3t FORCE UP TO	30.5 tonne GLW	LENGTH	(GLW)	SHEET
T T A A		mile/h ABOVE		23.2t FORCE ABOVE		4	9	W1404

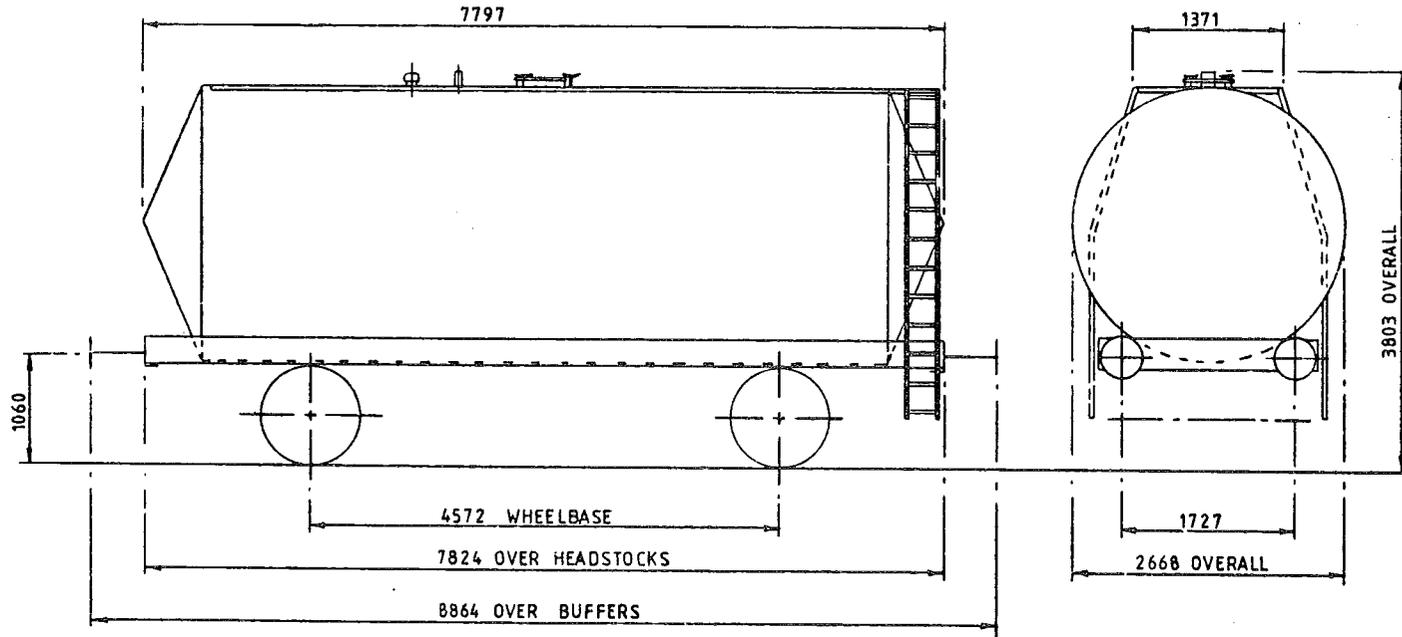

TARE-	14,000 Kg
CAPACITY, WEIGHT-	32,000 Kg
CAPACITY, VOLUME-	34,710 litres
MIN. CURVE-	31m
GEN. ARRGT. DRG. NO.-	

BRAKE-	AIR BLOCK & HAND LEVER
SUSPENSION-	DOUBLE LINK & PARABOLIC SPRING
COUPLINGS-	INSTANTER
BUFFERS-	HYDRAULIC 406DIA HEADS
WHEELS-	952 DIA
JOURNALS-	140 DIA ROLLER DIAGRAM

ISSUE 1

46 tonnes GL.W. TANK WAGON - ACETIC ACID

TTO67B

EXCESS LENGTH	4	H	M	L	E
tonnes	46	46	13	13	
VB	0	0	0	0	
AB	25	25	10	10	
RA	8	6	1	1	
MAX SPEED	60	60	45	45	

TOPS CODE									
CARKND		AARKND			OPERATING PANEL No				
T	T	B	T	B	A	1	3	2	6

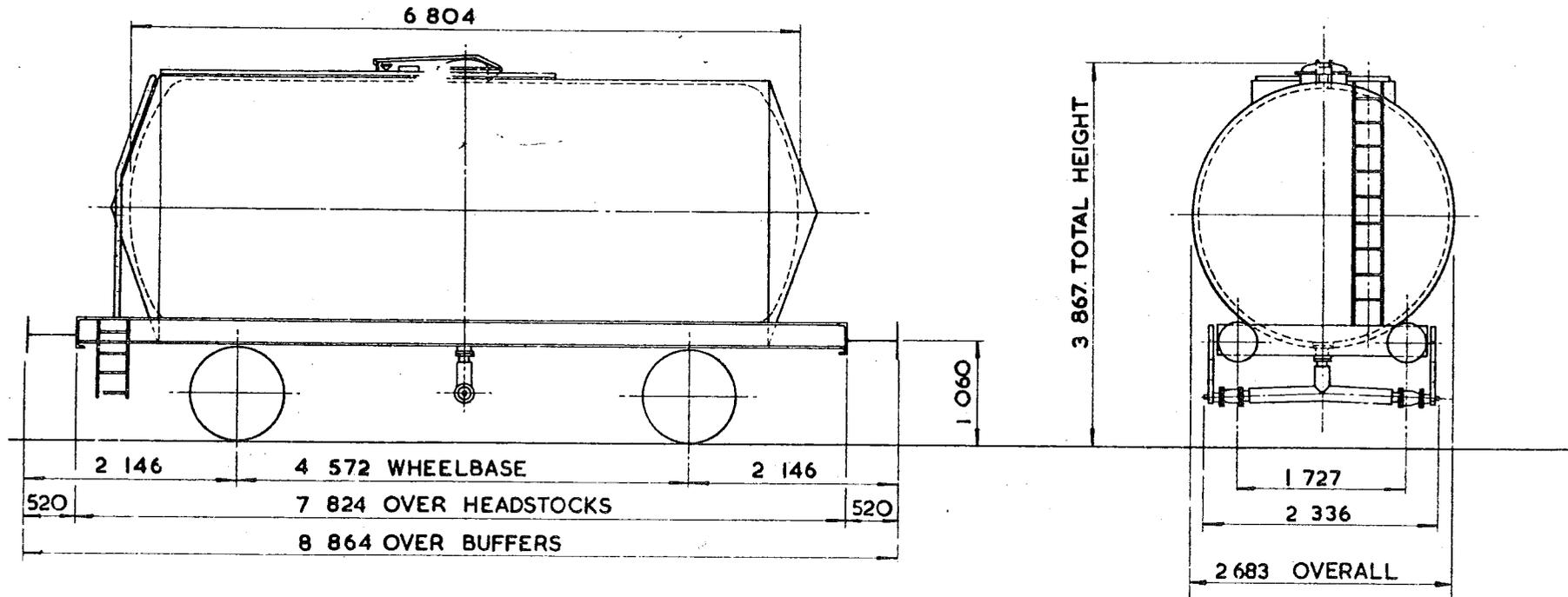

WEIGHT - 13200 kg
CARRYING CAPACITY - 32800 kg
CAPACITY -
MAX SPEED - 60 mile/h
WHEELS - 952 DIA.
JOURNALS - 140 DIA. ROLLER BEARINGS

BUFFERS - HYDRAULIC 406 DIA. HEADS
COUPLINGS - INSTANTER
MIN. CURVE - 31m
GEN. ARRGT. DRG. No -
BRAKE - AIR BLOCK, VACUUM PIPE & HAND LEVER
SUSPENSION - DOUBLE LINK

BUILDER - I.M.C. (HARTLEPOOL)
OWNER - STORAGE & TRANSPORT SYSTEMS
REGISTERED BY - C.M. & E.E. (B.R.B.) DERBY
YEAR BUILT - 1972
REGISTRATION Nos. - 53318 TO 53344
OWNER'S Nos. -

ISSUE 2
EX P.O. DIAGRAM 6/228 (ALLOCATED)

46 tonne GLW TANK WAGON

TT067C

EXCESS LENGTH	4	H	M	L	E
tonnes	46	46	13	13	
VB					
AB	25	25	9	9	
RA	8	8	1	1	
MAX SPEED	60	60	60	60	

TOPS CODE									
CARKND		AARKND			OPERATION				
T	T	A	A	A	A	1	3	7	L

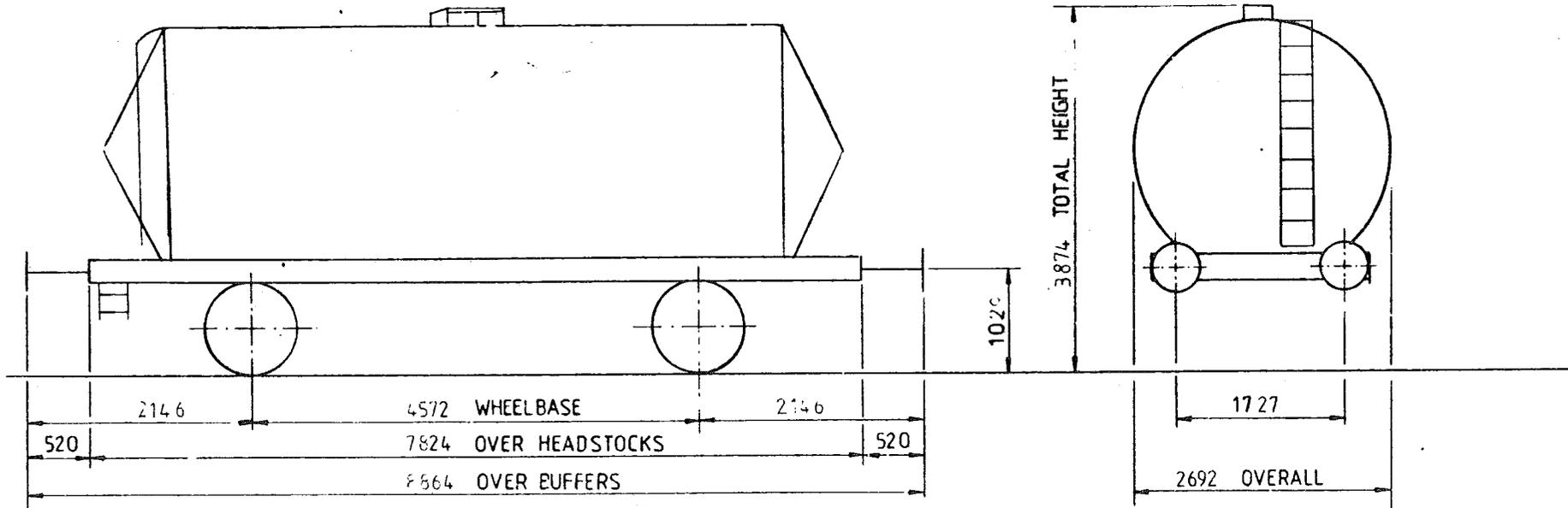

TARE	12850	kg
CARRYING CAPACITY -	33100	kg
CAPACITY -	32633	Litres
MAX SPEED	60	mile/h
WHEELS	φ 952	
JOURNALS	φ 140	ROLLER BEARINGS

BUFFERS	HYDRAULIC	φ 406	HEADS
COUPLINGS	INSTANTER		
MIN CURVE	31m		
GEN ARRGT DRG No			
BRAKE	AIR BLOCK,	HAND LEVER	
SUSPENSION	FAT	26	

ISSUE 1

EX PO. DIAGRAM 3/752 (ALLOCATED)

46 tonne GLW TANK WAGON ACETIC ACID

TT 067D

EXCESS LENGTH	4	H	M	L	E
tonnes	46	46	13	13	
VB					
AB	25	25	10	10	
RA	8	8	1	1	
MAX SPEED	60	60	45	45	

TOPS CODE		
CARKND	AARKND	CLASS
T	A	A 1 4 7 1

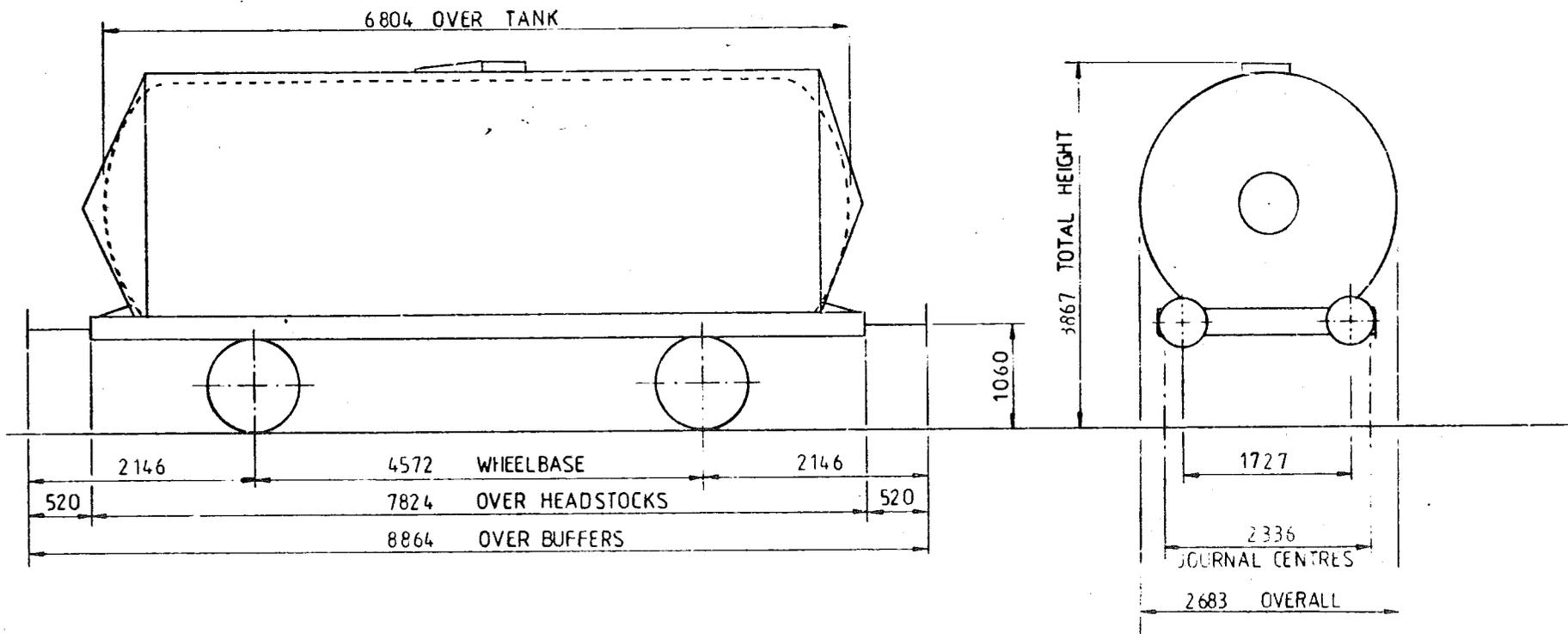

TARE	13200 kg
CARRYING CAPACITY -	32800 kg
CAPACITY -	Litres
MAX SPEED	60 mile/h
WHEELS	Ø 952
JOURNALS	Ø 140 ROLLER BEARINGS

BUFFERS	HYDRAULIC Ø 406 HEADS
COUPLINGS	INSTANTER
MIN CURVE	31m
GEN ARRGT DRG No.	
BRAKE	AIR BLOCK, HAND LEVER
SUSPENSION	DOUBLE LINK

ISSUE 1

EX PO DIAGRAM 5: 228 (ALLOCATED)

46 tonne GLW TANK WAGON (ACETIC ACID, ETHANOL)

LOT NUMBER	

TOPS INFORMATION						
AARKND	OPERATING	OPERATING SPEED		BRAKE FORCE DATA		EXCESS LENGTH
CARKND	PANEL No.	60 mile/h UP TO	46 tonne GLW	10t FORCE UP TO	37 tonne GLW	RA (GLW)
T T A A		mile/h ABOVE		25t FORCE ABOVE		4
						8
						W 954

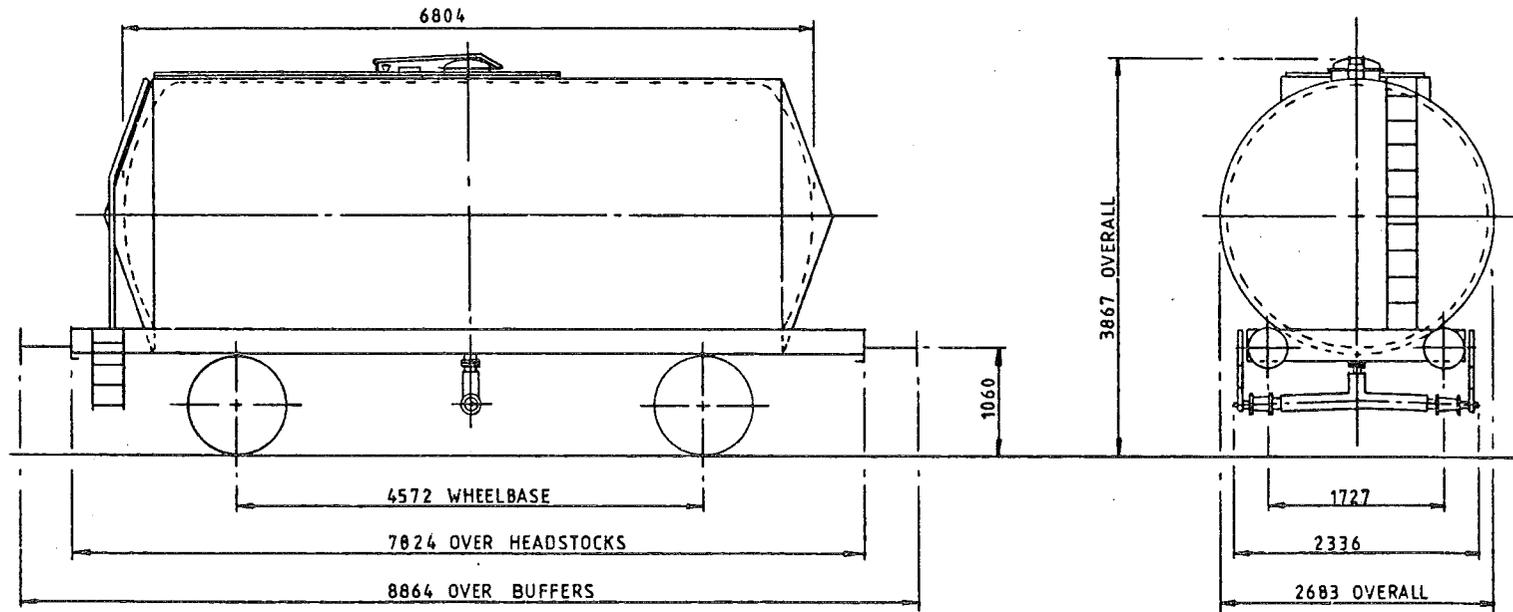

TARE-	12,300 Kg
CAPACITY, WEIGHT-	33,700 Kg
CAPACITY, VOLUME-	
MIN. CURVE-	31m
GEN. ARRGT. DRG. NO.-	

BRAKE-	AIR BLOCK & HAND LEVER
SUSPENSION-	DOUBLE LINK & PARABOLIC SPRING
COUPLINGS-	INSTANTER
BUFFERS-	HYDRAULIC 406 DIA HEADS
WHEELS-	952 DIA
JOURNALS-	140 DIA ROLLER BEARINGS

ISSUE 1

46 tonnes G.L.W. TANK WAGON - CAUSTIC LIQUOR

TTO68C

EXCESS LENGTH	4	H	M	L	E
tonnes	46	46	14	14	
VB	20	20	8	8	
AB					
RA	8	8	1	1	
MAX. SPEED	60	60	45	45	

TOPS CODE										
CARKND		AARKND		OPERATING PANEL No						
T	T	F	T	T	F	A	I	5	0	2

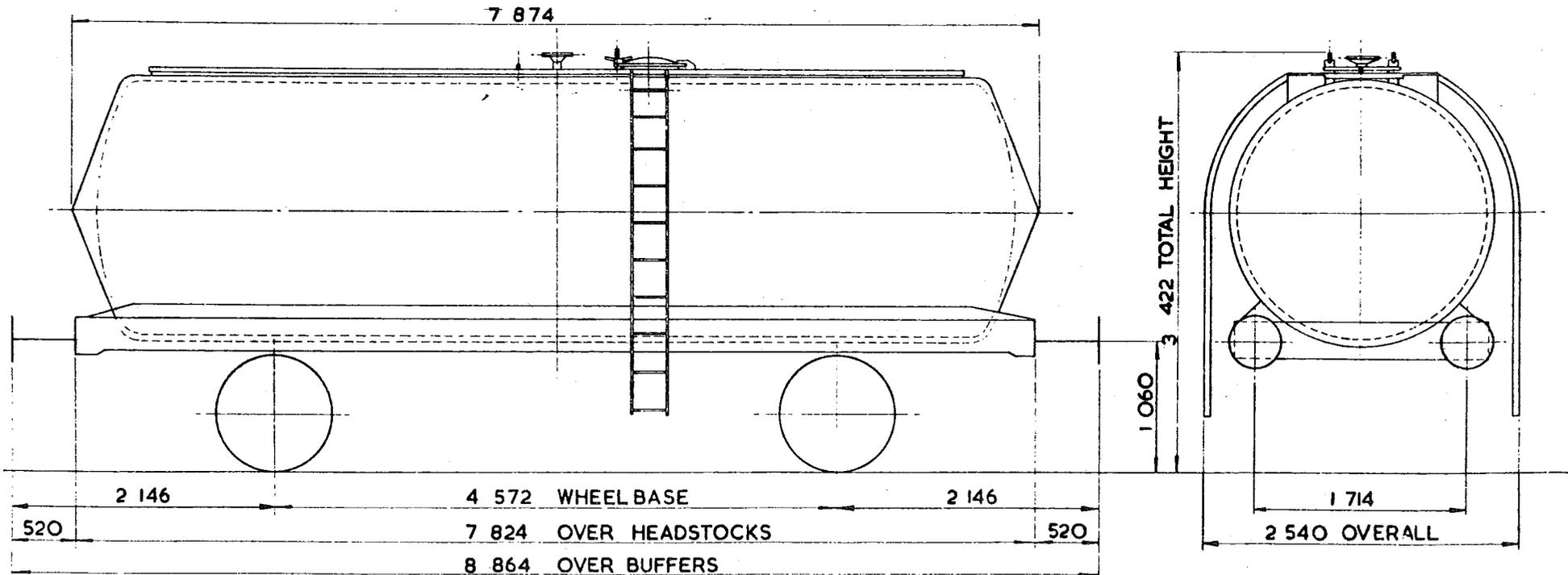

TARE - 13 600 kg
CARRYING CAPACITY - 32 400 kg
CAPACITY - 21 775 litres
MAX. SPEED - 60 mile/h
WHEELS - 952 DIA.
JOURNALS - 140 DIA. ROLLER BEARINGS

BUFFERS - HYDRAULIC 406 DIA. HEADS
COUPLINGS - INSTANTER
MIN. CURVE - 31m
GEN. ARRGT. DRG No. -
BRAKE - VACUUM BLOCK & HAND LEVER
SUSPENSION - DOUBLE LINK

BUILDER - PRESSED STEEL
OWNER - B.R.T. & E. LTD.
REGISTERED BY - C.M. & E.E. (B.R.B.) DERBY
YEAR BUILT - 1966
REGISTRATION Nos - 57194 TO 57243 (RANGE)
OWNERS Nos - 5760 TO 5809

ISSUE 1

EX PO. DIAGRAM 6/192

46 tonne GLW TANK WAGON CAUSTIC LIQUOR

TT068E

EXCESS LENGTH	4	H	M	L	E
tonnes	46	46	13	13	
VB					
AB	23	23	10	10	
PA	8	8	1	1	
MAX SPEED	60	60	60	60	

TOPS CODE	
MARKND	AARKND
T T A T T A A 1 6 1 2	

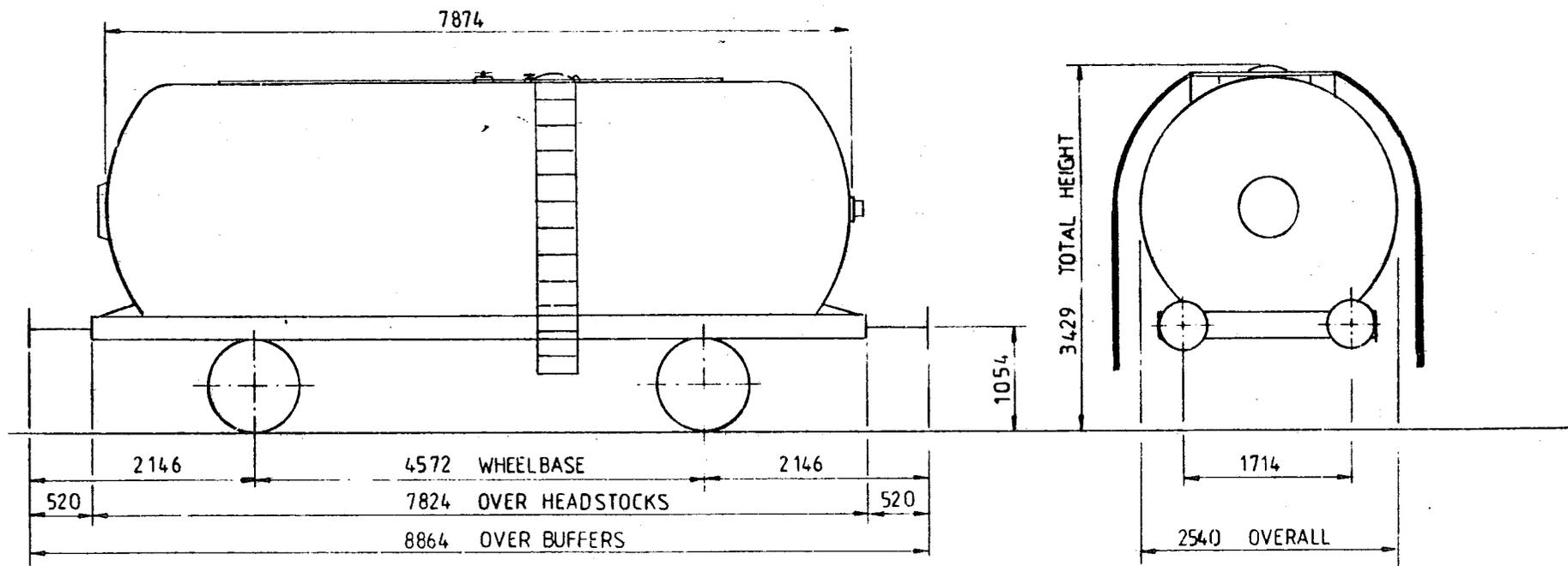

TARE	13450 kg
CARRYING CAPACITY -	32500 kg
CAPACITY -	23171 Litres
MAX SPEED	60 mile/h
WHEELS	φ 952
JOURNALS	φ 140 ROLLER BEARINGS

BUFFERS	HYDRAULIC φ 406 HEADS
COUPLINGS	INSTANTER
MIN CUR. R.	31m
GEN ARRGT DRG No.	
BRAKE	AIR BLOCK, HAND LEVER
SUSPENSION	FAT 26

ISSUE 1

EX PO. DIAGRAM 6/193 (ALLOCATED)

46 tonnes G.L.W. TANK WAGON - CAUSTIC SODA

TTO69A

EXCESS LENGTH	4	H	M	L	E
tonnes	46	46	13	13	
VB	0	0	0	0	
AB	22	22	7	7	
RA	8	8	1	1	
MAX SPEED	60	60	45	45	

TOPS CODE									
CARKND		AARKND			OPERATING PANEL No				
T	T	B	T	B	A	I	S	I	7

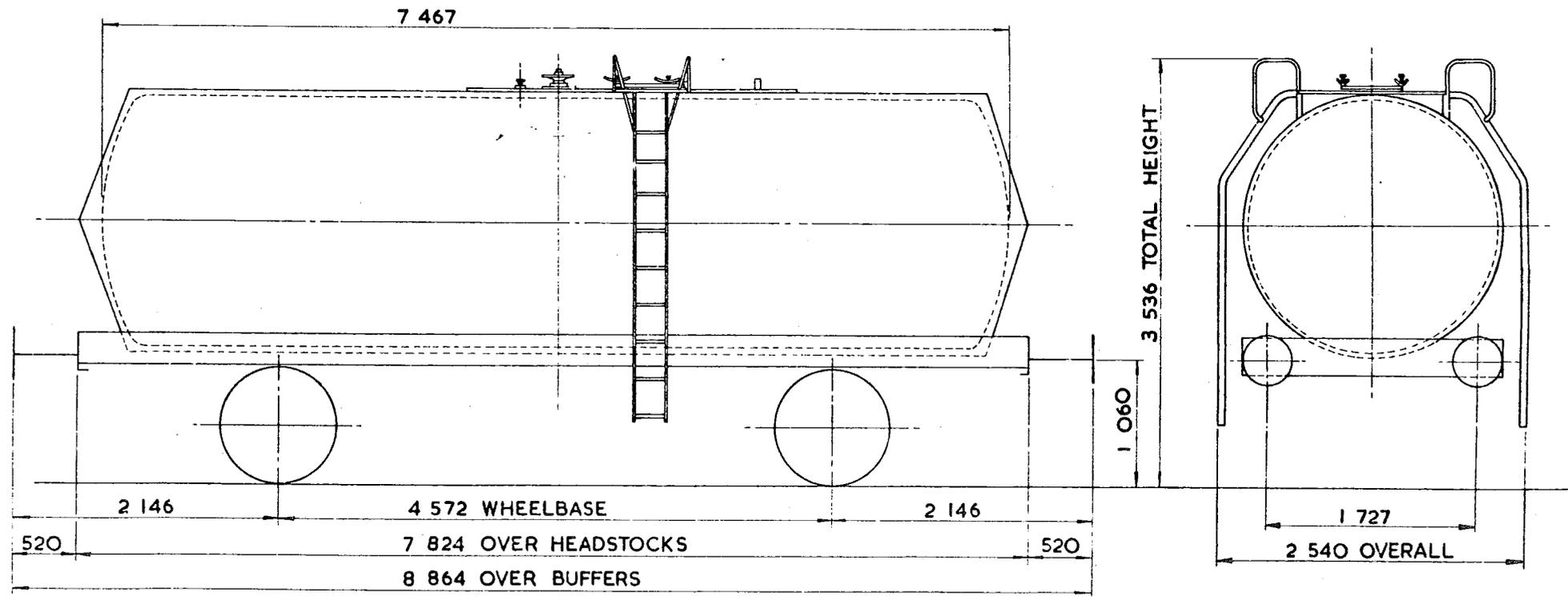

TARE -- 13 ¹⁵⁰ kg
CARRYING CAPACITY - 32 ⁸⁰⁰ kg
CAPACITY - 23 ⁴⁰³ litres
MAX. SPEED - 60 mile/h
WHEELS - 952 DIA.
JOURNALS - 140 DIA. ROLLER BEARINGS

BUFFERS - HYDRAULIC 406 DIA. HEADS
COUPLINGS - INSTANTER
MIN CURVE - 31m
GEN. ARRGT. DRG. No -
BRAKE - AIR BLOCK, VACUUM PIPED & HAND LEVER
SUSPENSION - DOUBLE LINK

BUILDER - METRO CAMELL
OWNER - B.R.T. & E. LTD.
REGISTERED BY - C.M. & E.E. (B.R.B.) DERBY
YEAR BUILT - 1966
REGISTRATION Nos - 57697 TO 57746 (RANGE)
OWNERS Nos - 10347 TO 10396

ISSUE 2
EX PO. DIAGRAM 6/194

46 tonne GLW TANK WAGON CAUSTIC LIQUOR.

TT 069C

EXCESS LENGTH	4	H	M	L	E
tonnes	46	46	13	13	
VB					
AB	22	22	7	7	
BA	8	8	1	1	
MAX SPEED	60	60	60	60	

TOPS CODE					
CARKND	AARKND	OPERATION	PANEL		
T	T	A	A	1	6
				1	3

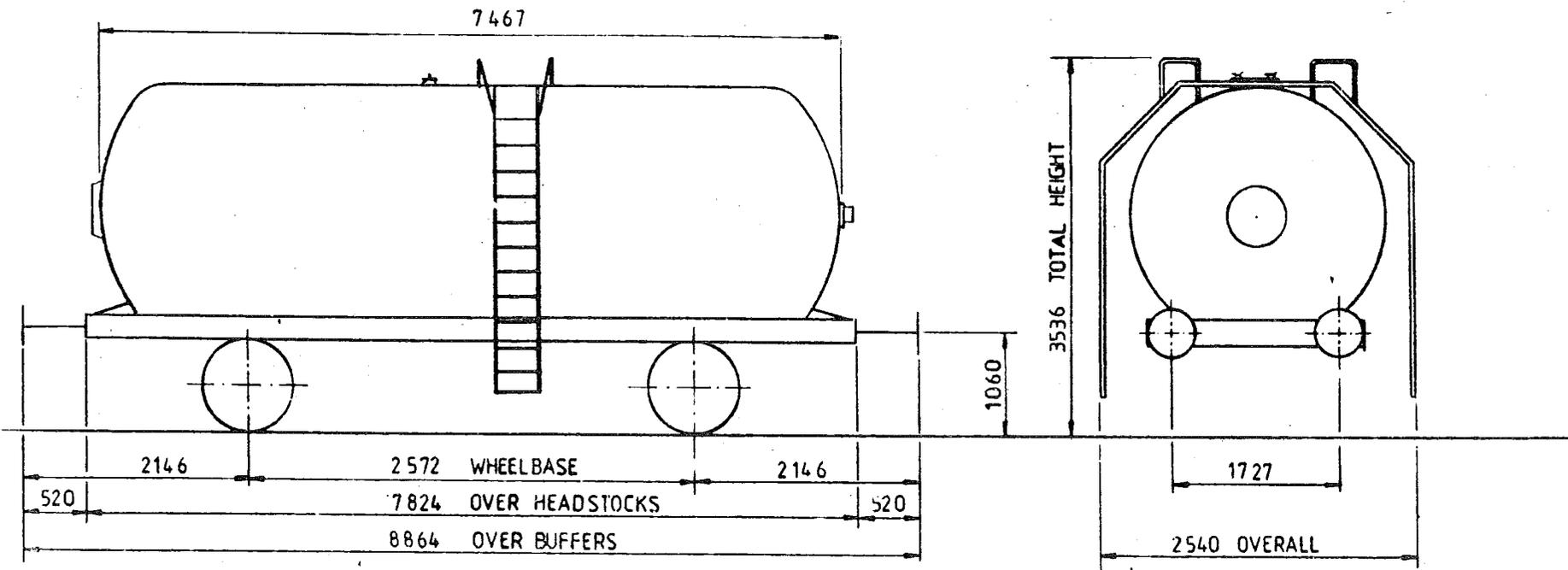

TARE	13150	kg
CARRYING CAPACITY -	32800	kg
CAPACITY -	23403	Litres
MAX SPEED	60	mile/h
WHEELS	φ 952	
JOURNALS	φ 140	ROLLER BEARINGS

BUFFERS	HYDRAULIC	φ 406	HEADS
COUPLINGS	INSTANTER		
MIN CURVE	31m		
GEN ARRGT	ORG No.		
BRAKE	AIR BLOCK,	HAND LEVER	
SUSPENSION	FAT	26	

ISSUE 1

EX PO. DIAGRAM 6/194 (ALLOCATED)

46 tonnes G.L.W. TANK WAGON - CAUSTIC LIQUOR

TTO70A

EXCESS LENGTH	4	H	M	L	E
tonnes	46	46	13	13	
VB	0	0	0	0	
AB	26	26	10	10	
RA	8	8	1	1	
MAX SPEED	60	60	60	60	

TOPS CODE										
CARKND		AARKND			OPERATING PANEL					
T	T	B	T	T	B	A	1	4	8	8

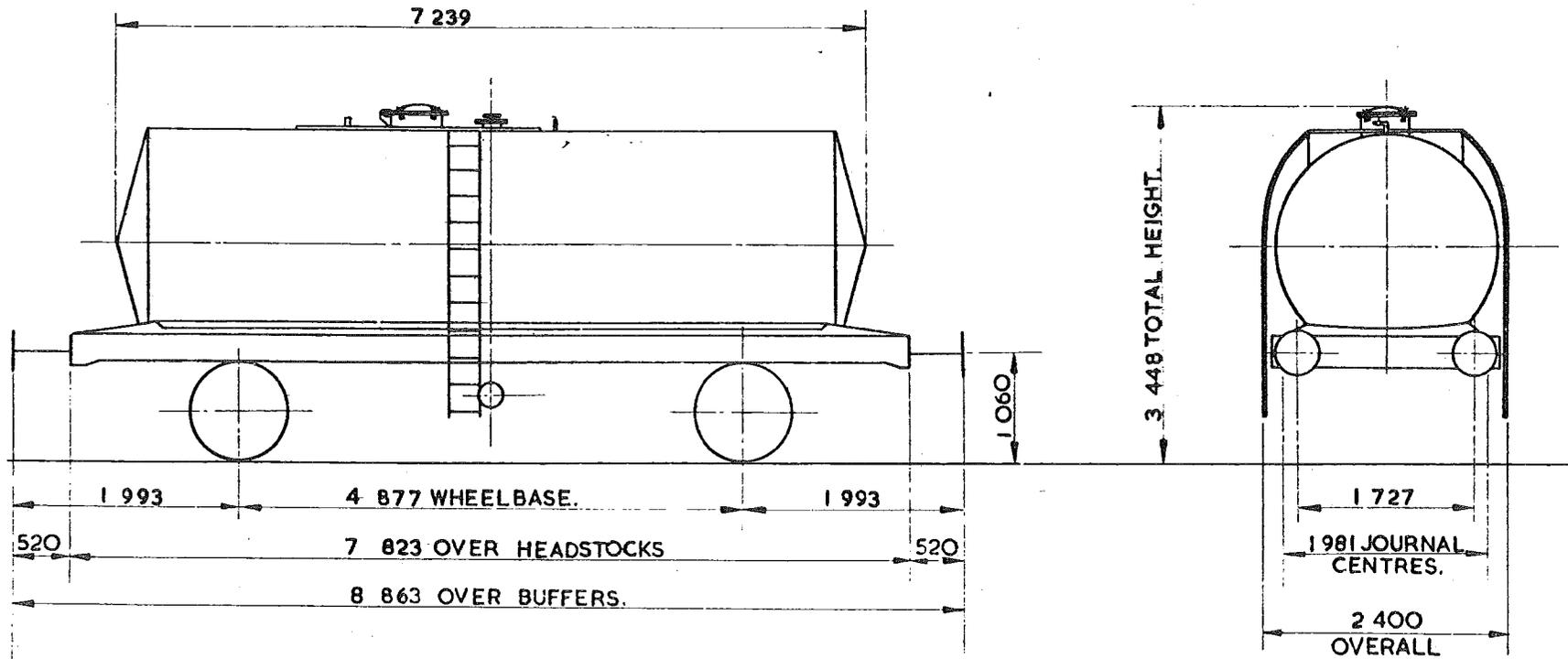

WEIGHT -	13 200 kg
CARRYING CAPACITY -	32 600 kg
CAPACITY -	21 871 litres
MAX SPEED	60 mile/h
WHEELS -	952 DIA.
JOURNALS	140 DIA. ROLLER BEARINGS.

BUFFERS -	HYDRAULIC 406 DIA. HEADS
COUPLINGS -	INSTANTER
MIN. CURVE -	31 m
GEN. ARRGT. DRG. No -	
BRAKE -	AIR BLOCK, VACUUM PIPED & HAND LEVER
SUSPENSION -	DOUBLE LINK.

BUILDER -	STANDARD RAILWAY WAGON Co.
OWNER -	PROCOR (U.K.) LTD.
REGISTERED BY -	C.M. & E.E. (B.R.B.) DERBY
YEAR BUILT -	1971
REGISTRATION Nos -	58400. TO 58599. (RANGE)
OWNERS Nos. -	C.L.I. TO C.L.I.05.

4.6 tonne GLW TANK WAGON UREA FORMALDEHYDE RESIN

TT070B

EXCESS LENGTH	4	H	M	L	E
tonnes	46	46	13	13	
VB	0	0	0	0	
AB	26	26	10	10	
RA	8	8	1	1	
MAX SPEED	60	60	60	60	

TOPS CODE					
CARKND	AARKND	OPERATION			
T	T	B	T	T	B
A	1	6	0	0	

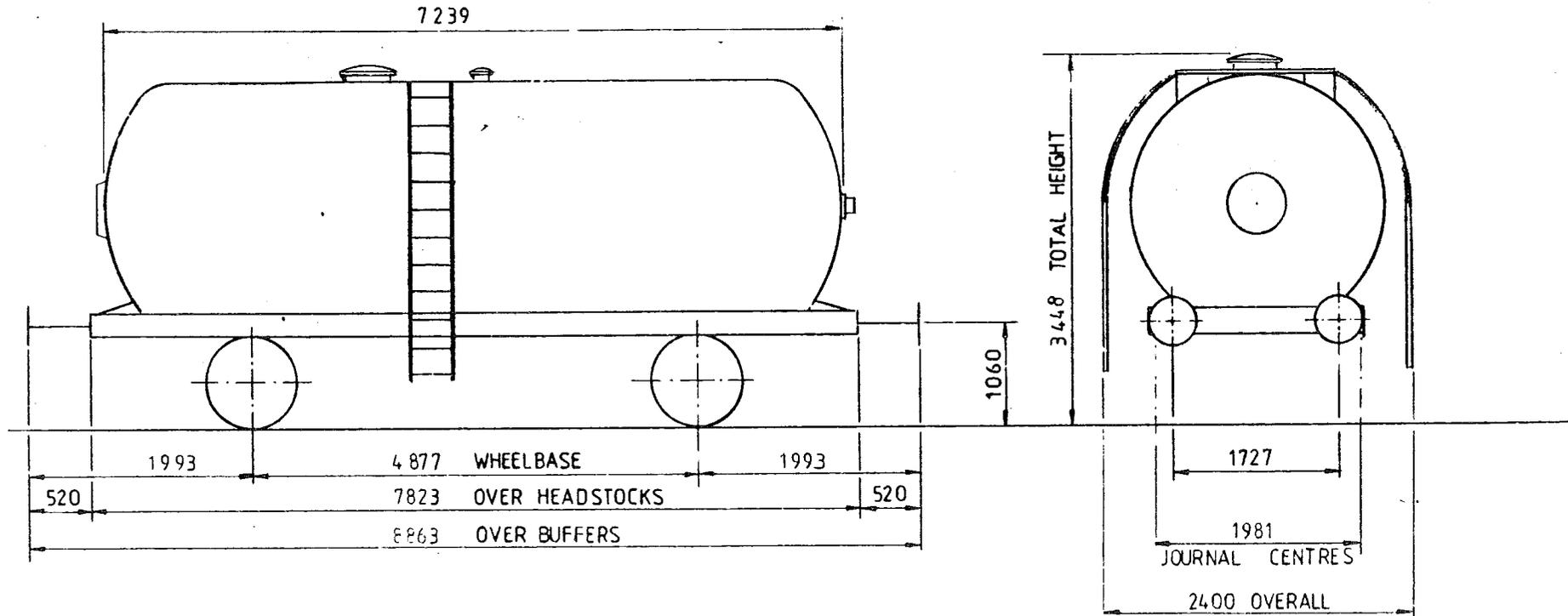

TARE	13150	kg
CARRYING CAPACITY -	32800	kg
CAPACITY -	38186	Litres
MAX SPEED	60	mile/h
WHEELS	φ 952	
JOURNALS	φ 140	ROLLER BEARINGS

BUFFERS	HYDRAULIC φ 406	HEADS
COUPLINGS	INSTANTER	
MIN CURVE	31m	
GEN ARRGT DRG No		
BRAKE	AIR BLOCK, VACUUM PIPED, HAND LEVER	
SUSPENSION	DOUBLE LINK	

ISSUE 1

EX - PO. DIAGRAM 6/219 [ALLOCATED]

46 tonne GLW TANK WAGON UREA FORMALDEHYDE RESIN

TT070C

EXCESS LENGTH	H	M	L	E
4				
tonnes	46	46	13	13
VB	0	0	0	0
AB	26	26	10	10
RA	8	8	1	1
MAX SPEED	60	60	60	60

TOPS CODE					
CARKND	AARKND	OPERATION			
T	T	B	T	B	A
			6	0	0

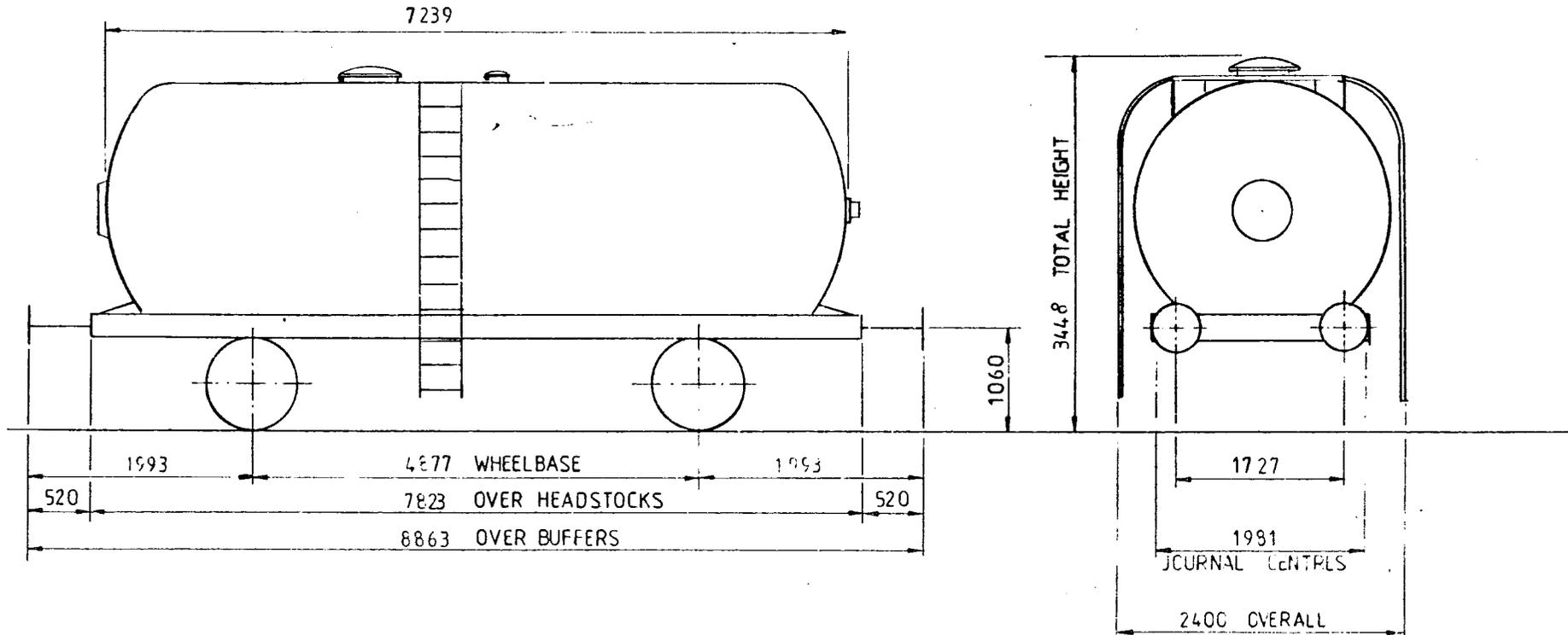

TARE	13800	kg
CARRYING CAPACITY -	32200	kg
CAPACITY -	39122	Litres
MAX SPEED	60	mile/h
WHEELS	φ 952	
JOURNALS	φ 140	ROLLER BEARINGS

BUFFERS	HYDRAULIC	φ 406	HEADS
COUPLINGS	INSTANTER		
MIN CURVE	31m		
GEN ARRGT	DRG N.		
BRAKE	AIR BLOCK, VACUUM PIPED, HAND LEVER		
SUSPENSION	DOUBLE LINK		

ISSUE 1

EX PO DIAGRAM 6/219 (ALLOCATED)

4.6 tonne G.L.W. TANK WAGON UREA FORMALDEHYDE RESIN

TT070D

DESIGN SHEET No. W.772

EXCESS LENGTH	H	M	L	E
4				
tonnes	46	46	13	13
VB	0	0	0	0
AB	26	26	10	10
RA	8	8	1	1
MAX SPEED	60	60	60	60

TOPS CODE					
CARKND	AARKND		OPERATING PANEL No.		
T	T	B	T	B	A
			1	6	0
				0	

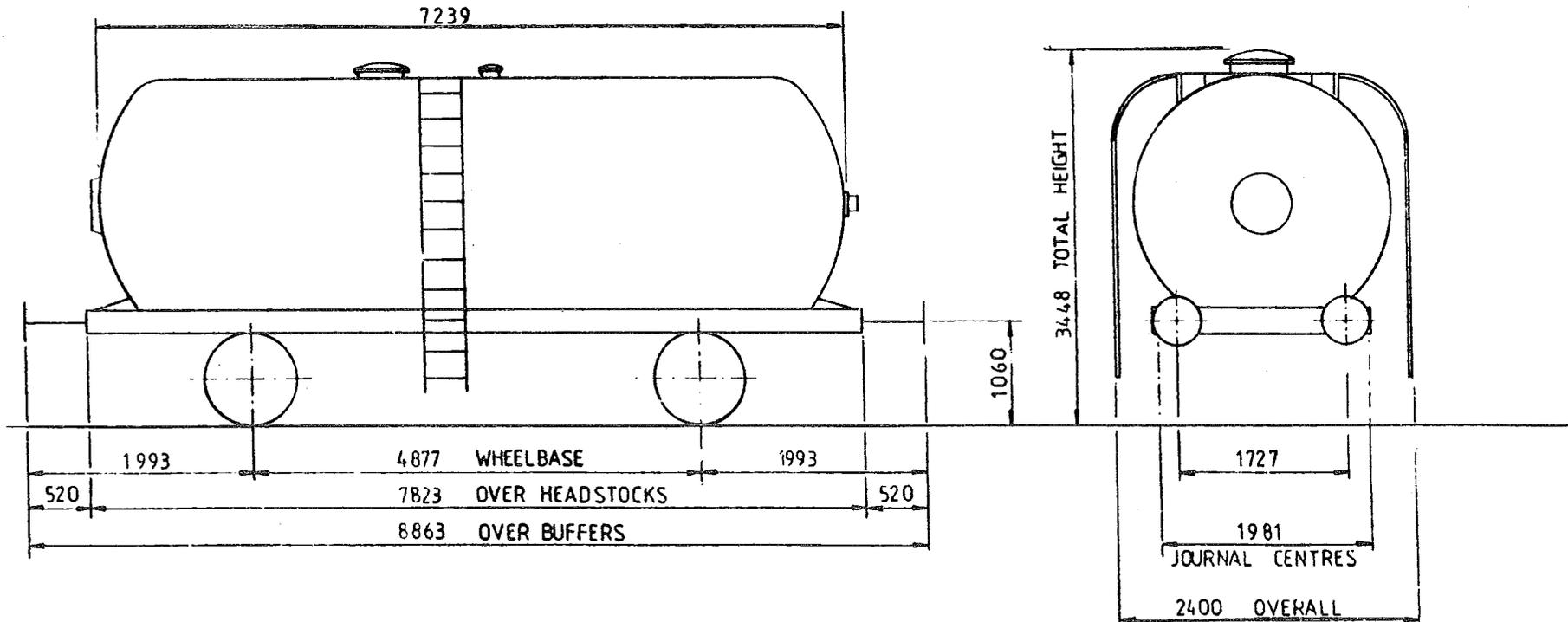

TARE -	13 ⁰⁵⁰	kg
CARRYING CAPACITY -	32 ⁹⁰⁰	kg
CAPACITY -	39550	Litres
MAX SPEED -	60	mile/h
WHEELS -	φ 952	
JOURNALS -	φ 140	ROLLER BEARINGS

BUFFERS -	HYDRAULIC φ 406 HEADS
COUPLINGS -	INSTANTER
MIN CURVE -	31m
GEN. ARRGT. DRG No -	
BRAKE -	AIR BLOCK, VACUUM PIPED HAND LEVER
SUSPENSION -	DOUBLE LINK

ISSUE 2.

EX. PN DIAGRAM 4/219 (A) (01/ATL)

46 tonne GLW TANK WAGON—CAUSTIC LIQUOR

LOT NUMBER	

TOPS INFORMATION								
AARKND	OPERATING	OPERATING SPEED		BRAKE FORCE DATA		EXCESS	RA	DESIGN
CARKND	PANEL No.	60 mile/h UP TO		10t FORCE UP TO		LENGTH	(GLW)	SHEET
T T A		46 tonne GLW		26t FORCE ABOVE		4	8	W1002
		mile/h ABOVE		31 tonne GLW				

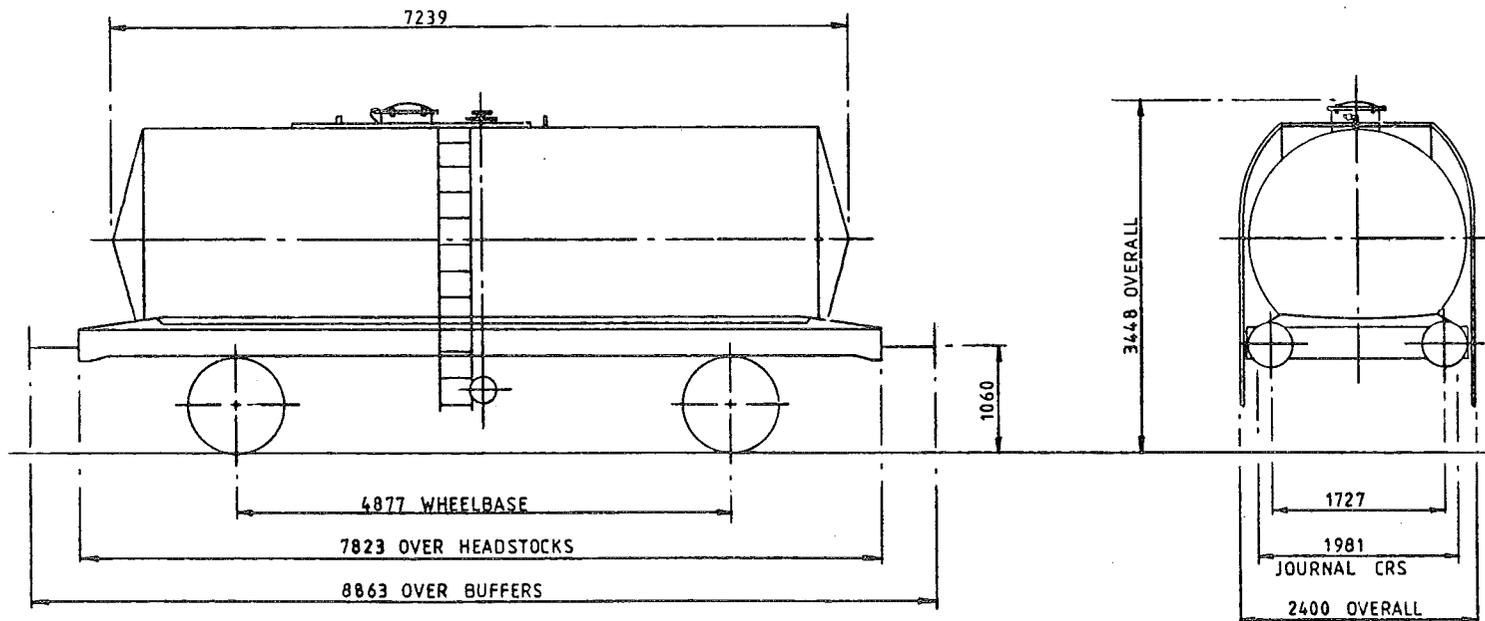

TARE-	13300 Kg
CAPACITY, WEIGHT-	32700 Kg
CAPACITY, VOLUME-	21871 litres
MIN. CURVE-	31m
GEN. ARRGT. DRG. NO.-	

BRAKE-	AIR BLOCK & HAND LEVER
SUSPENSION-	DOUBLE LINK
COUPLINGS-	INSTANTER
BUFFERS-	HYDRAULIC 406 DIA. HEADS
WHEELS-	952 DIA.
JOURNALS-	140 DIA. ROLLER BEARINGS

ISSUE 1

41 tonne GLW TANK WAGON (MOLASSES)

LOT NUMBER	

TOPS INFORMATION						
AARKND	OPERATING	OPERATING SPEED		BRAKE FORCE DATA		EXCESS LENGTH
CARKND	PANEL No.	60 mile/h UP TO	41 tonne GLW	10t FORCE UP TO	31 tonne GLW	RA (GLW)
T T A		mile/h ABOVE		26t FORCE ABOVE		DESIGN SHEET
						W1097

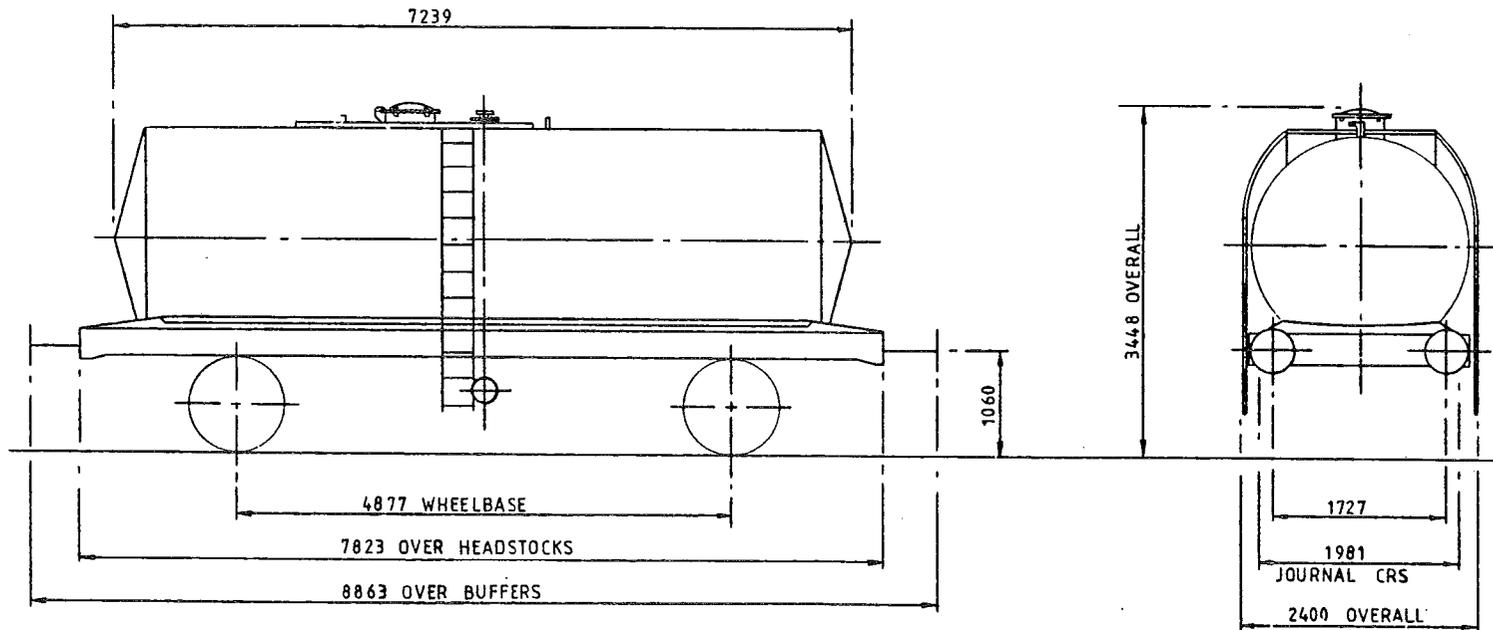

TARE-	13000 Kg
CAPACITY, WEIGHT-	28000 Kg
CAPACITY, VOLUME-	21871 litres
MIN. CURVE-	31m
GEN. ARRGT. DRG. NO.-	

BRAKE-	AIR BLOCK & HAND LEVER
SUSPENSION-	DOUBLE LINK
COUPLINGS-	INSTANTER
BUFFERS-	HYDRAULIC 406 DIA. HEADS
WHEELS-	952 DIA.
JOURNALS-	140 DIA. ROLLER BEARINGS

ISSUE 1

46 tonnes G.L.W TANK WAGON - CHINA CLAY SLURRY

TTO71A

EXCESS LENGTH	4	H	M	L	E
tonnes	46	46	18	13	
VB					
AB	29	29	10	10	
RA	8	4	1	1	
MAX. SPEED	60	60	45	45	

TOPS CODE						
CARKND	AARKND		OPERATING PANEL No			
T	T	A	T	A	A	1327

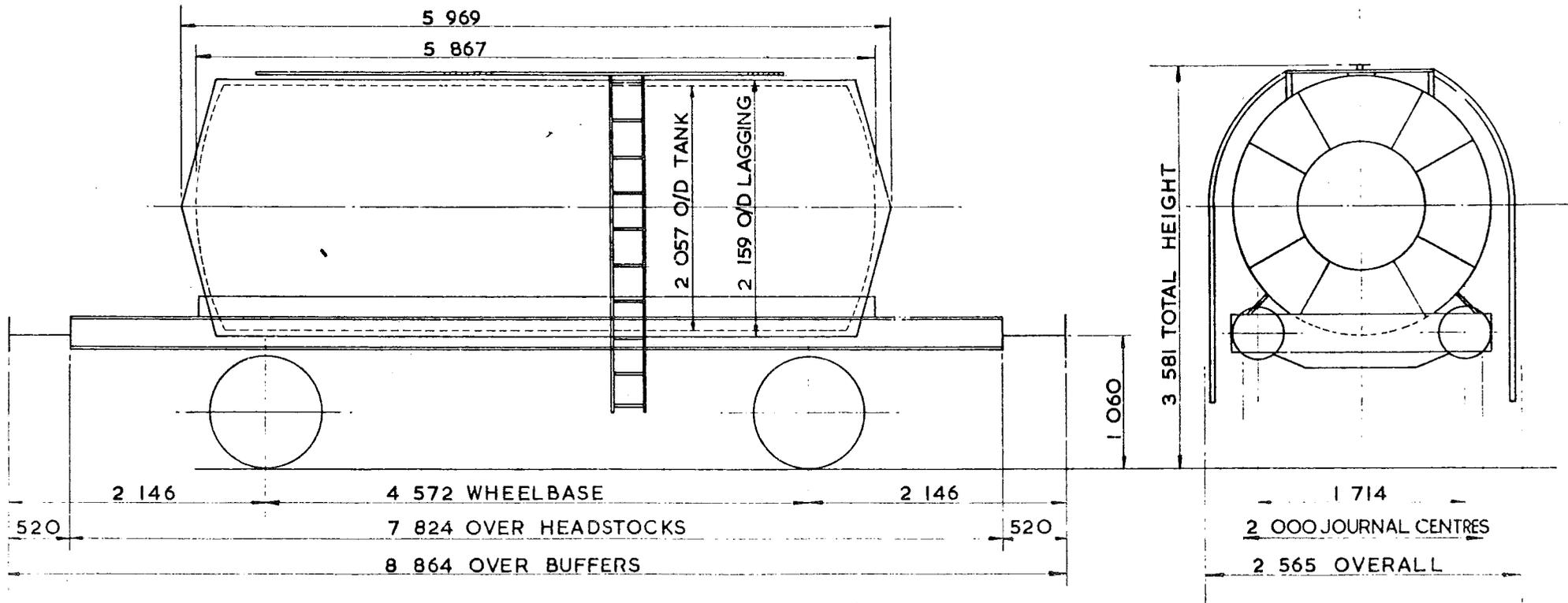

TARE - 13200kg
CARRYING CAPACITY - 32600 kg
CAPACITY - 19138 litres
MAX. SPEED - 60 mile/h
WHEELS - 952 DIA.
JOURNALS - 140 DIA. ROLLER BEARINGS

BUFFERS - HYDRAULIC 406 DIA. HEADS
COUPLINGS - INSTANTER
MIN. CURVE - 31 m
GEN. ARRGT. DRG. No. -
BRAKE - AIR BLOCK & HAND LEVER
SUSPENSION - DOUBLE LINK

BUILDER - I. M. C. (HARTLEPOOL)
OWNER - STORAGE & TRANSPORT SYSTEMS
REGISTERED BY - C.M. & E.E.(B.R.B) DERBY
YEAR BUILT - 1971
REGISTRATION Nos. - 53129
OWNERS Nos. - 1029

46 tonne GLW TANK WAGON CHINA CLAY SLURRY

TT071B

EXCESS LENGTH	4	H	M	L	E
tonnes	46	46	13	13	
VB					
AB	26	26	10	10	
RA	8	8	1	1	
MAX SPEED	60	60	60	60	

TOPS CODE		
CARKND	AARKND	PERMANENT
T	T	A
T	T	A
A	A	1
0	7	0

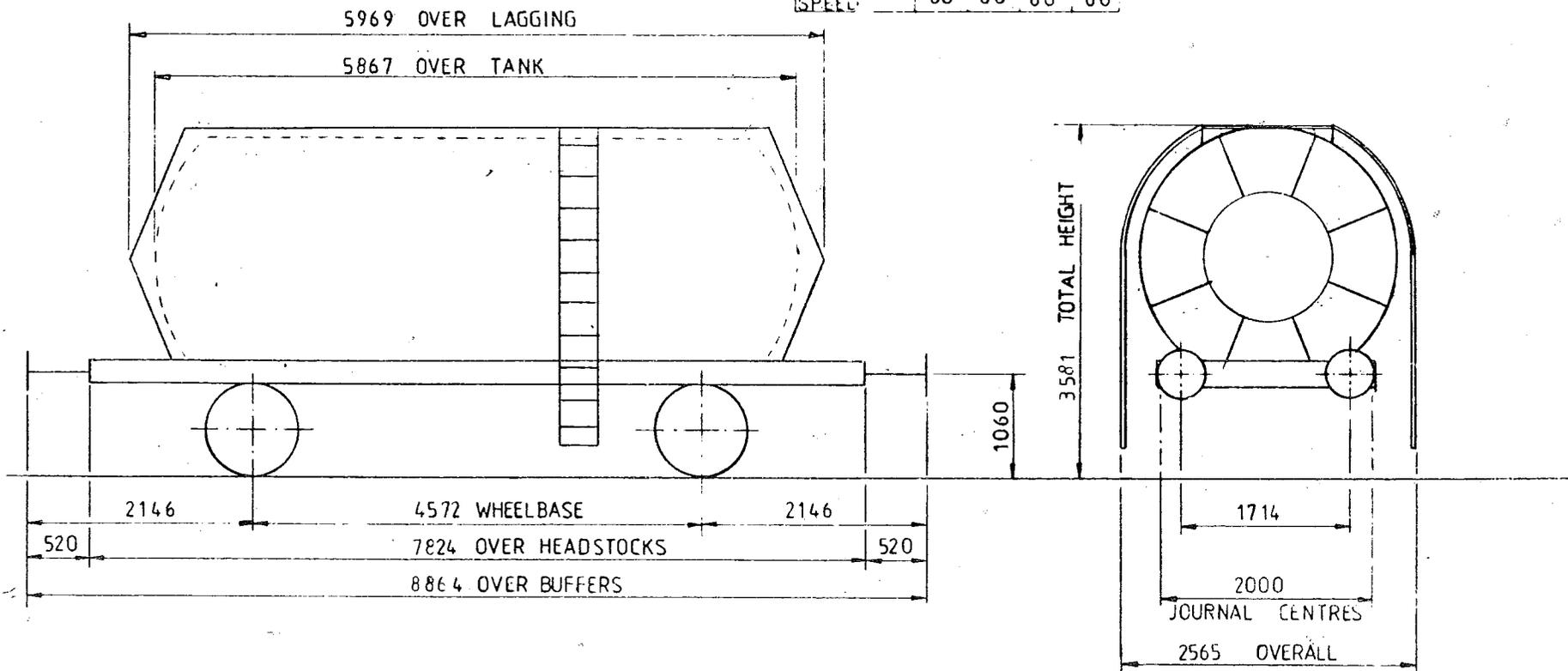

TARE	13200 kg
CARRYING CAPACITY -	32800 kg
CAPACITY -	19138 Litres
MAX SPEED	60 mile/h
WHEELS	φ 952
JOURNALS	φ 140 ROLLER BEARINGS

BUFFER	HYDRAULIC φ 406 HEADS
COUPLINGS	INSTANTER
MIN CURVE	31m
GEN ARRGT DRG No.	
BRAKE	AIR BLOCK, HAND LEVER
SUSPENSION	Double link with parabolic superleaf springs

ISSUE 1

EX PO. DIAGRAM 6/229 (ALLOCATED)

46 tonnes G.L.W. TANK WAGON

TT072 A

EXCESS LENGTH	4	H	M	L	E
tonnes	46	46	14	14	
VB	0	0	0	0	
AB	23	23	9	9	
RA	8	8	1	1	
MAX SPEED	60	60	45	45	

TOPS CODE							
CARKND		AARKND		OPERATING PANEL N...			
T	T	B	T	T	B	A	1 5 2 8

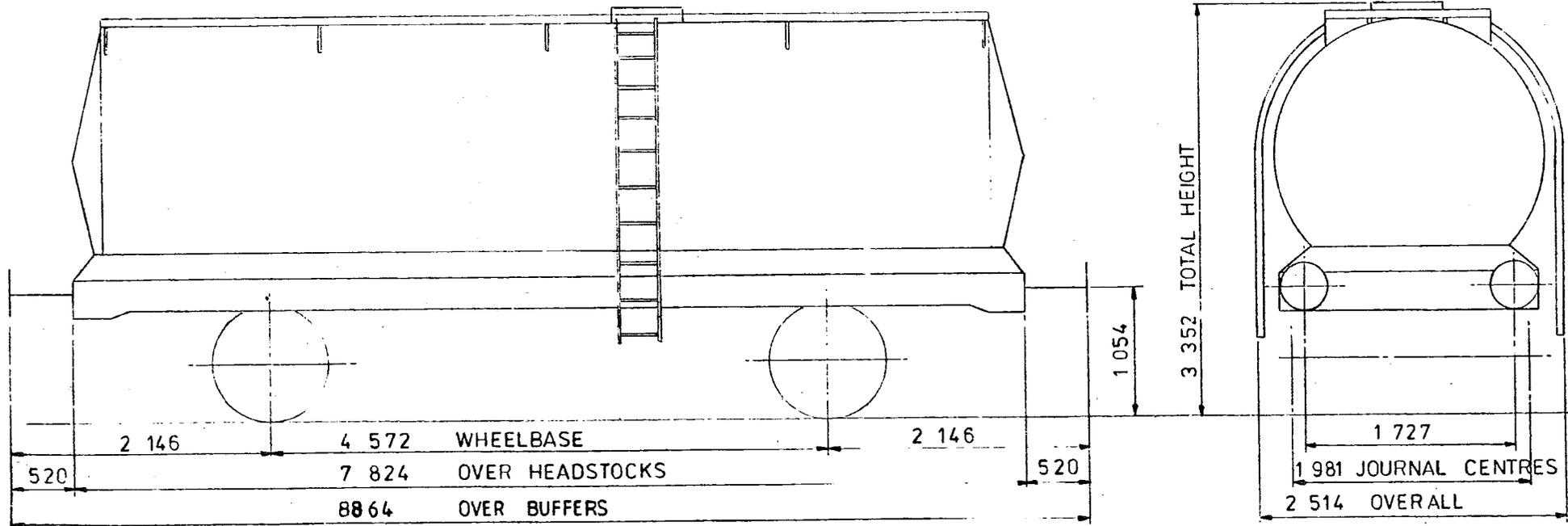

TARE	13700kg
CARRYING CAPACITY	32360 kg
CAPACITY	21889 litres
MAX SPEED	60 mile/h
WHEELS	952 DIA.
JOURNALS	140 DIA. ROLLER BEARINGS

BUFFERS	HYDRAULIC 406 DIA. HEADS
COUPLINGS	INSTANTER
MIN CURVE	31m
GEN ARRGT DRG No.	
BRAKE	AIR BLOCK, VACUUM PIPED & HAND LEVER
SUSPENSION	DOUBLE LINK

ISSUE 3

EX. P.O. DIAGRAM 6/755 (ALLOCATED)

46 tonne GLW TANK WAGON

TT072B

EXCESS LENGTH	H	M	L	E
4				
tonnes	46	46	14	14
VB				
AB	18	18	7	7
RA	8	8	1	1
MAX SPEED	60	60	60	60

TOPS CODE									
CARKND		AARKND		OPERATION					
T	T	A	T	T	A	A	S	S	S

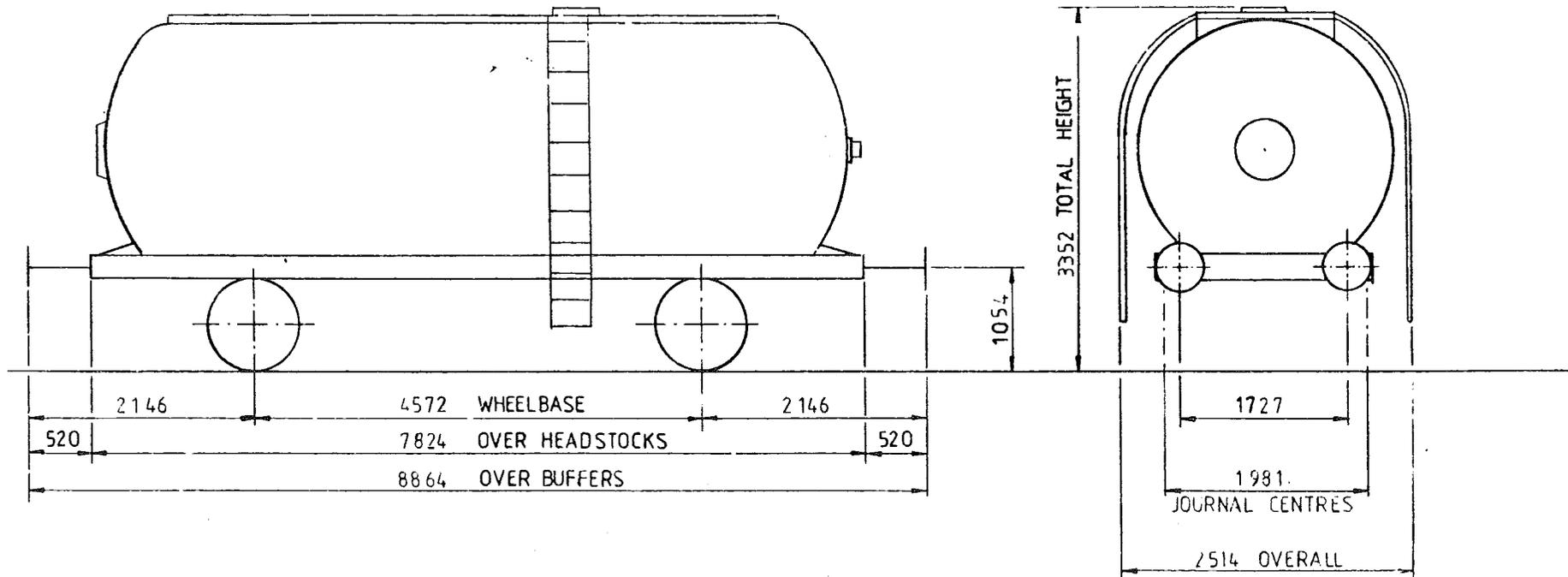

TARE	13 ⁷⁰⁰ kg
CARRYING CAPACITY	32 ³⁰⁰ kg
CAPACITY	21889 Litres
MAX SPEED	60 mile/h
WHEELS	φ 952
JOURNALS	φ 140 ROLLER BEARINGS

BUFFERS	HYDRAULIC φ 406 HEADS
COUPLINGS	INSTANTER
MIN CURVE	31m
GEN ARRGT DRG No	
BRAKE	AIR BLOCK, HAND LEVER
SUSPENSION	DOUBLE LINK

ISSUE 1

EX PO. DIAGRAM 6/765 (A) CATED.

46 tonne GLW TANK WAGON

LOT NUMBER	

TOPS INFORMATION								
AARKND	OPERATING	OPERATING SPEED		BRAKE FORCE DATA		EXCESS LENGTH	RA (GLW)	DESIGN SHEET
CARKND	PANEL No.	60 mile/h UP TO	46 tonne GLW	9t FORCE UP TO	31 tonne GLW	4	9	W1146
T T A		mile/h ABOVE		23t FORCE ABOVE				W1150

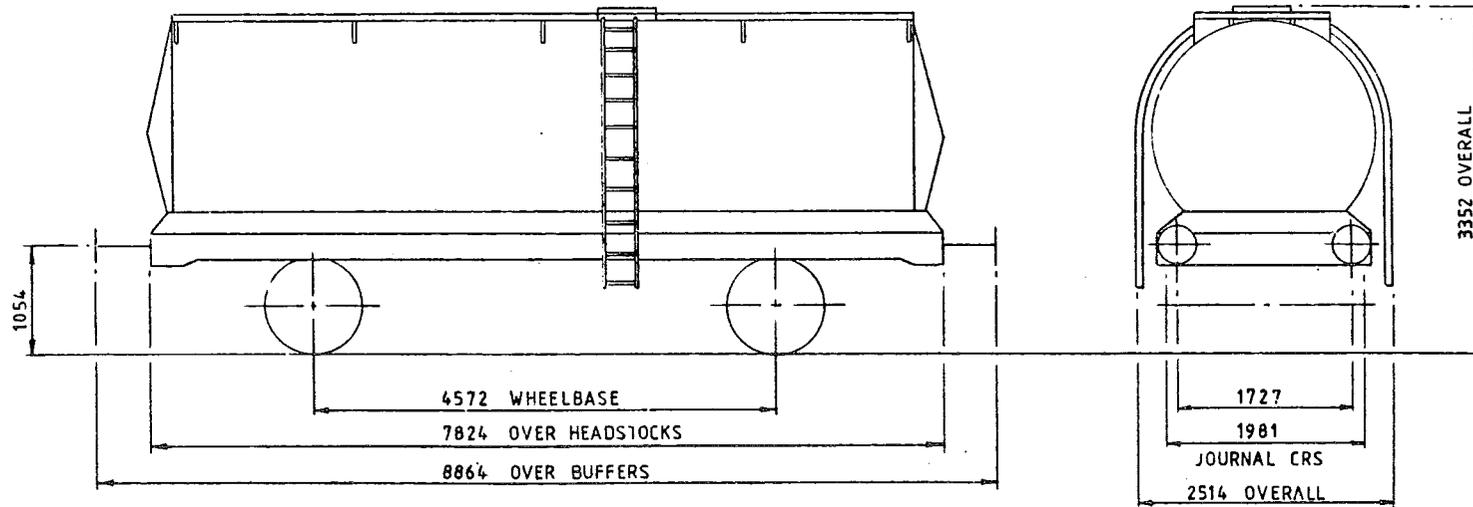

TARE-	12,500 Kg
CAPACITY, WEIGHT-	33,500 Kg
CAPACITY, VOLUME-	21,889 litres
MIN. CURVE-	31m
GEN. ARRG. DRG. NO.-	

BRAKE-	AIR BLOCK & HAND LEVER
SUSPENSION-	U/C DOUBLE LINK & PARABOLIC SPRING
COUPLINGS-	INSTANTER
BUFFERS-	HYDRAULIC 406 DIA HEADS
WHEELS-	952 DIA
JOURNALS-	140 DIA ROLLER BEARINGS

ISSUE 1

46 tonne GLW TANK WAGON—CLAY SLURRY

LOT NUMBER	

TOPS INFORMATION										
AARKND	OPERATING			OPERATING SPEED		BRAKE FORCE DATA		EXCESS LENGTH	RA (GLW)	DESIGN SHEET
CARKND	PANEL No.			60 mile/h UP TO	46 tonne GLW	9t FORCE UP TO	31 tonne GLW	4	8	W1272
T T A A				mile/h ABOVE		23t FORCE OVER				

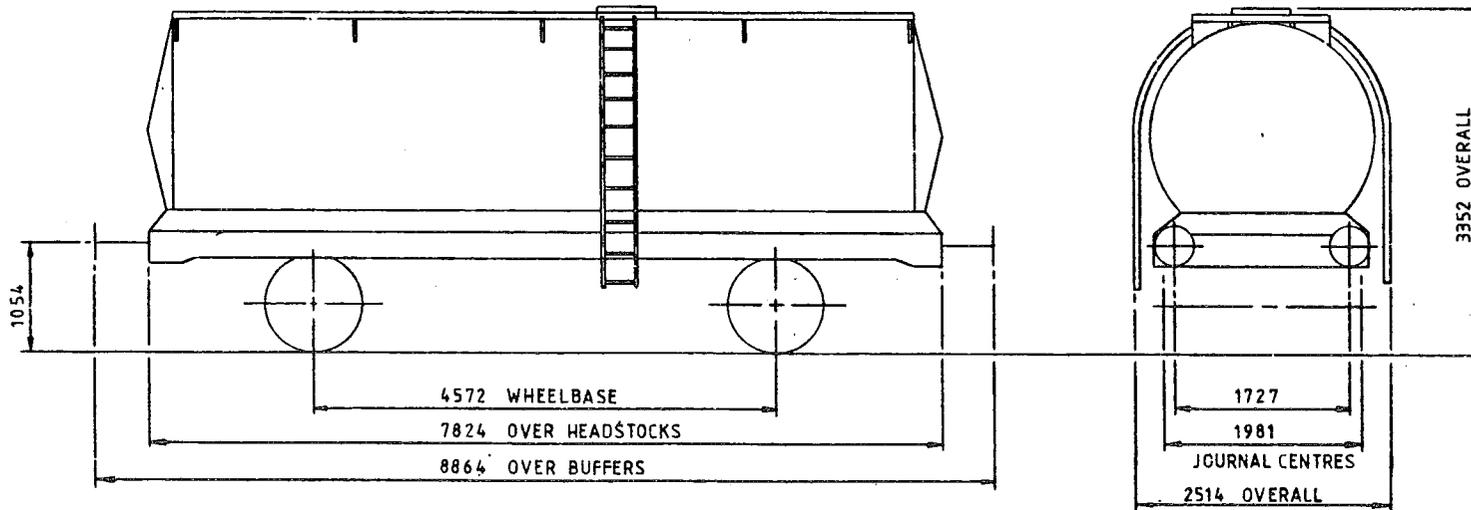

TARE-	13,400 Kg
CAPACITY, WEIGHT-	32,600 Kg
CAPACITY, VOLUME-	21,889 litres
MIN. CURVE-	31m
GEN. ARRGT. DRG. NO.-	

BRAKE-	AIR BLOCK & HAND LEVER
SUSPENSION-	DOUBLE LINK & PARABOLIC SPRING
COUPLINGS-	INSTANTER
BUFFERS-	HYDRAULIC 406 DIA. HEADS
WHEELS-	952 DIA.
JOURNALS-	140 DIA ROLLER BEARINGS

ISSUE 1

46 tonne GLW TANK WAGON

LOT NUMBER	

TOPS INFORMATION						
AARKND	OPERATING	OPERATING SPEED		BRAKE FORCE DATA		EXCESS
CARKND	PANEL No.	45 mile/h UP TO	13.7 tonne GLW	9t FORCE UP TO	31 tonne GLW	LENGTH
T T A		60 mile/h ABOVE		23t FORCE ABOVE		4
						RA (GLW)
						8
						DESIGN SHEET
						WI327

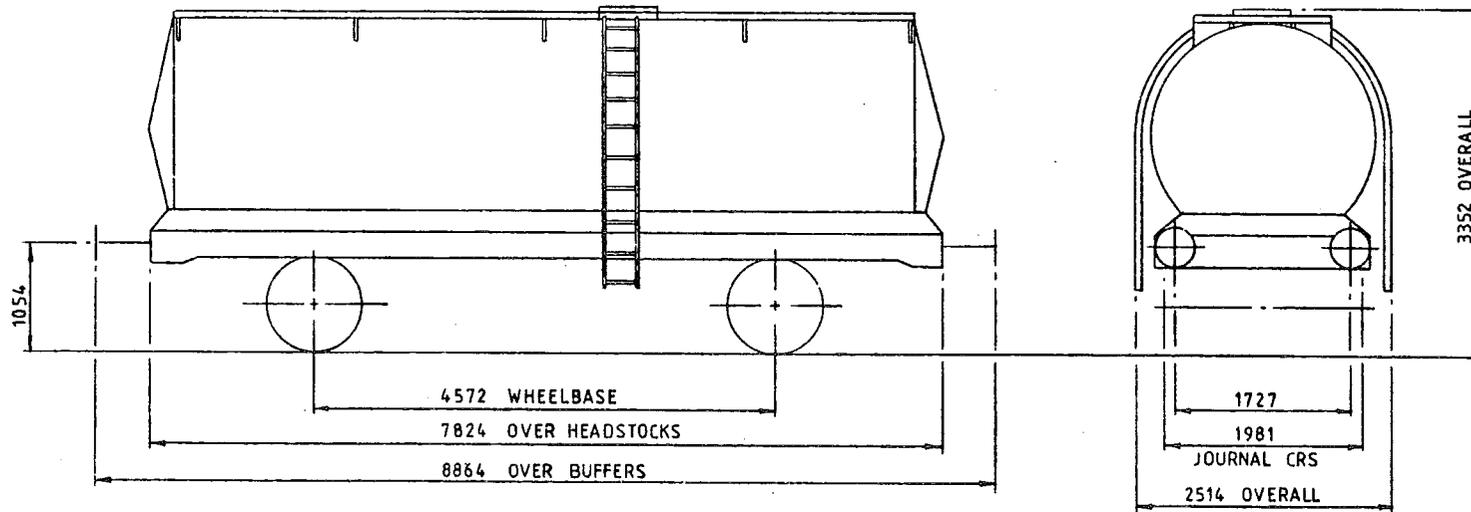

TARE-	13,700 Kg
CAPACITY, WEIGHT-	32,300 Kg
CAPACITY, VOLUME-	21,889 litres
MIN. CURVE-	31m
GEN. ARRGT. DRG. NO.-	

BRAKE-	AIR BLOCK & HAND LEVER
SUSPENSION-	DOUBLE LINK
COUPLINGS-	INSTANTER
BUFFERS-	HYDRAULIC 406 DIA. HEADS
WHEELS-	952 DIA.
JOURNALS-	140 DIA. ROLLER BEARINGS

ISSUE 1

46 tonne GLW TANK WAGON—CLASS 'A'

LOT NUMBER	

TOPS INFORMATION								
AARKND	OPERATING	OPERATING SPEED		BRAKE FORCE DATA		EXCESS LENGTH	RA (GLW)	DESIGN SHEET
CARKND	PANEL No.	60 mile/h UP TO	46 tonne GLW	9t FORCE UP TO	3t tonne GLW	4	9	W 464
T T A A		mile/h ABOVE		23t FORCE ABOVE				W 469

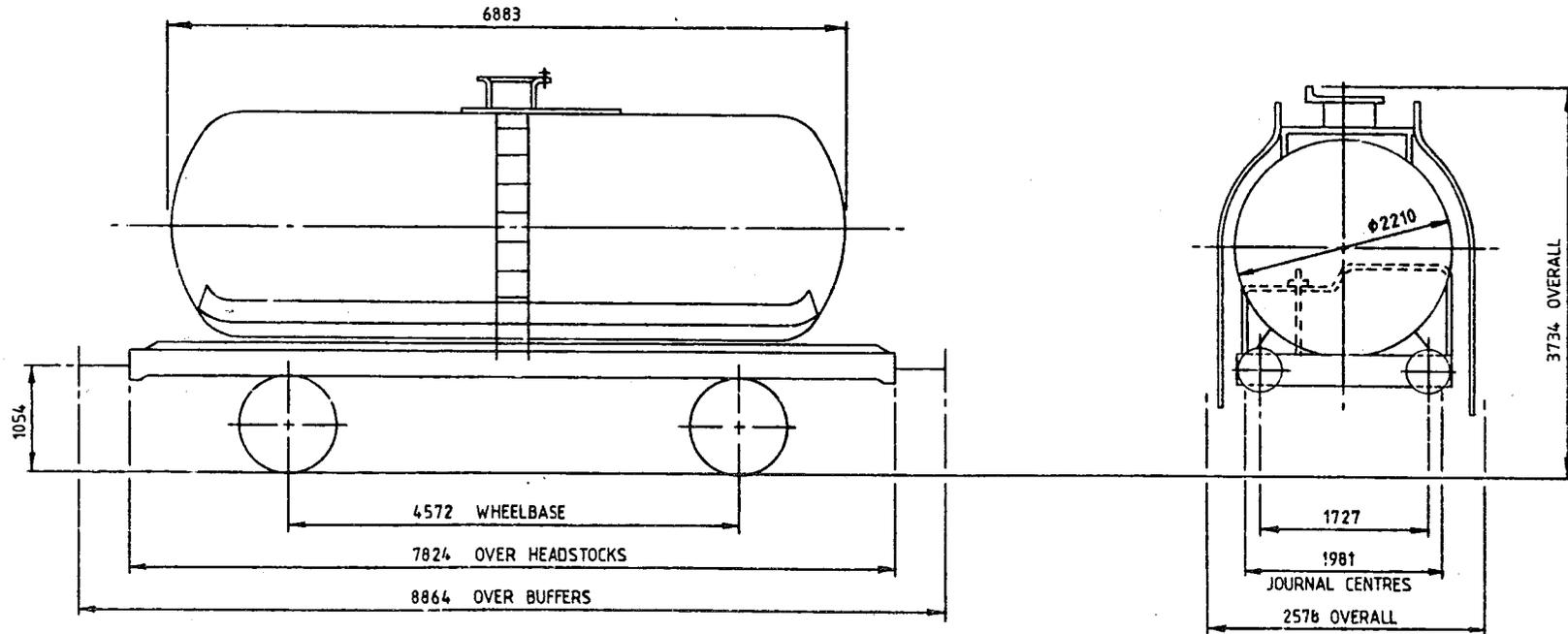

TARE-	13,000 Kg
CAPACITY, WEIGHT-	32000 Kg
CAPACITY, VOLUME-	23,700 litres
MIN. CURVE-	31m
GEN. ARRGT. DRG. NO.-	

BRAKE-	AIR BLOCK & HAND LEVER
SUSPENSION-	UIC DOUBLE LINK & PARABOLIC SPRING
COUPLINGS-	INSTANTER
BUFFERS-	HYDRAULIC 406 DIA. HEADS
WHEELS-	952 DIA.
JOURNALS-	140 DIA. ROLLER BEARINGS

ISSUE 1

46 tonne GLW TANK WAGON

LOT NUMBER	

TOPS INFORMATION						
AARKND	OPERATING	OPERATING SPEED		BRAKE FORCE DATA		EXCESS LENGTH
CARKND	PANEL No.	60 mile/h UP TO	46 tonne GLW	9t FORCE UP TO	31 tonne GLW	RA (GLW)
T T A A		mile/h ABOVE		23t FORCE ABOVE		4
						9
						DESIGN SHEET
						W1501
						W1502

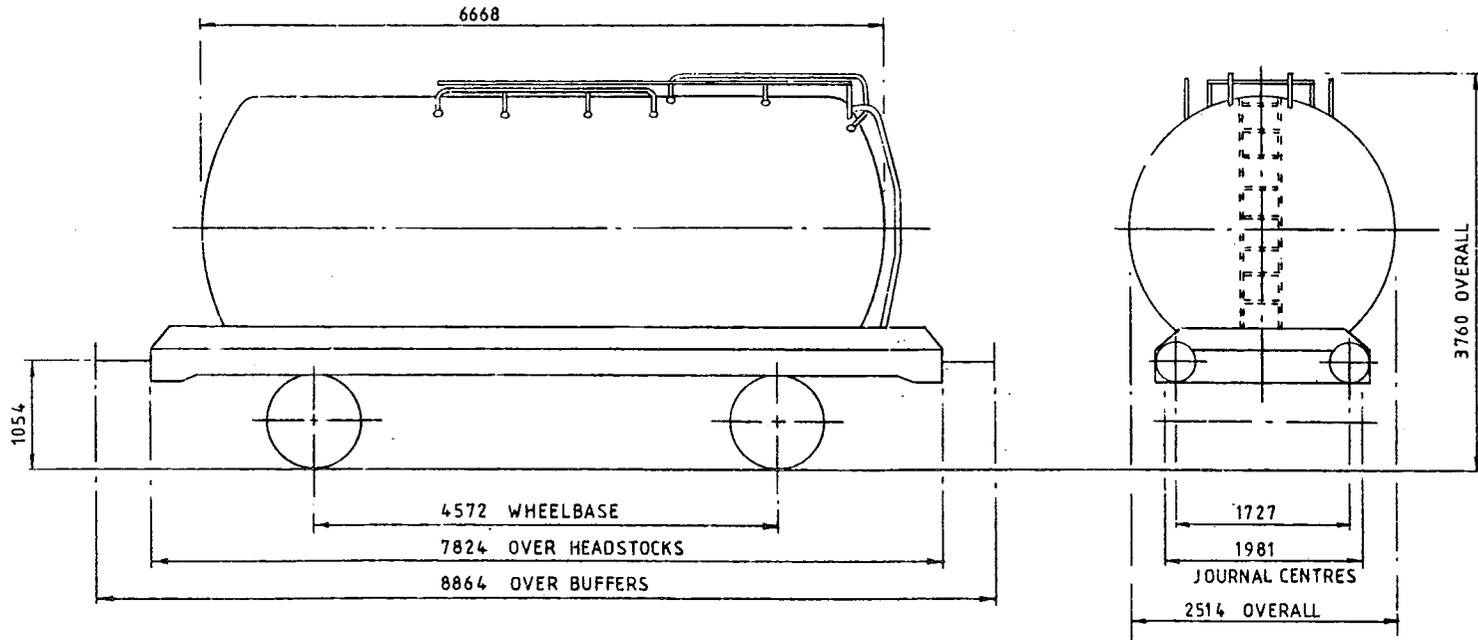

TARE-	13,900 Kg
CAPACITY, WEIGHT-	32,100 Kg
CAPACITY, VOLUME-	31,000 litres
MIN. CURVE-	31m
GEN. ARRGT. DRG. NO.-	

BRAKE-	AIR BLOCK & HAND LEVER
SUSPENSION-	DOUBLE LINK & PARABOLIC SPRING
COUPLINGS-	INSTANTER
BUFFERS-	HYDRAULIC 406 DIA HEADS
WHEELS-	952 DIA
JOURNALS-	140 DIA ROLLER BEARINGS

ISSUE 1

46 tonnes G.L.W. TANK WAGON

TTO73A

EXCESS LENGTH	5	H	M	L	E
tonnes	46	46	18	18	
VB	0	0	0	0	
AB	24	24	12	12	
RA	8	8	1	1	
MAX SPEED	60	60	60	60	

TOPS CODE										
CARKND		AARKND			OPERATING PANEL No					
T	T	B	T	T	B	A	1	2	4	5

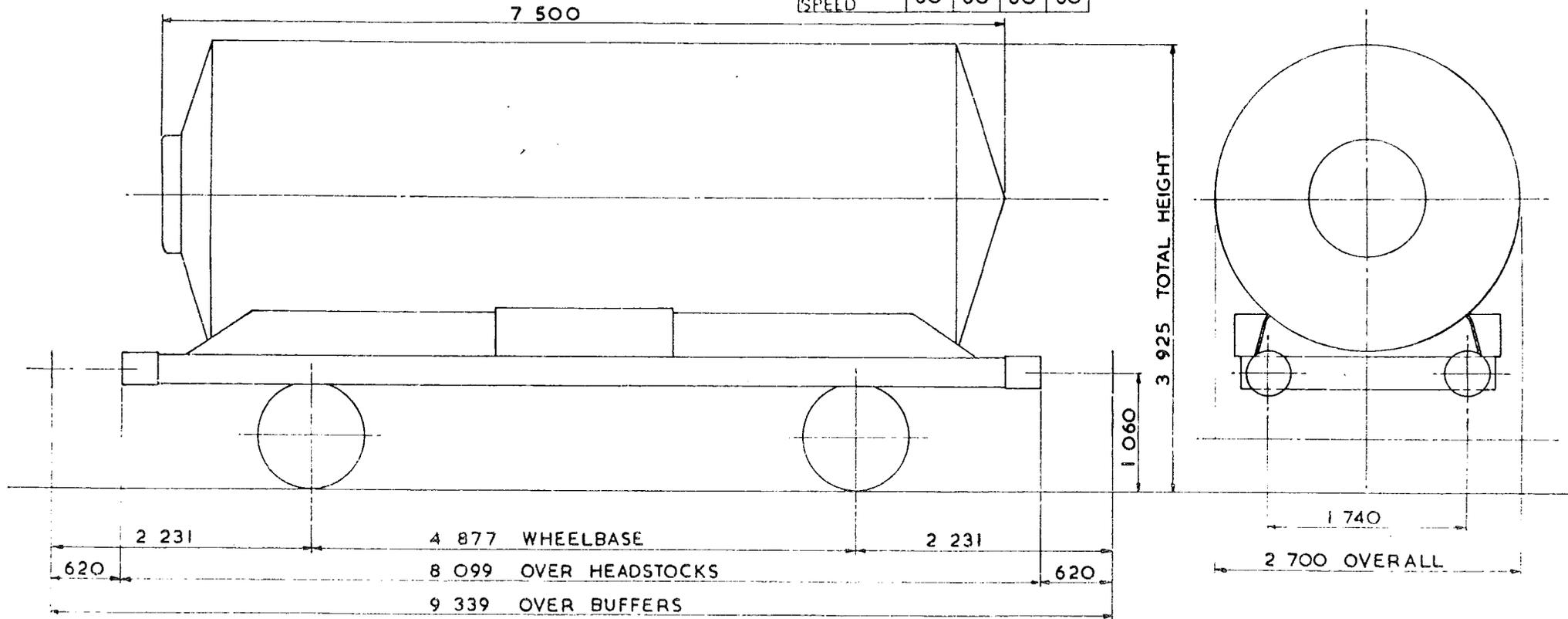

TARE	17 500 kg
CARRING CAPACITY	28 500 kg
CAPACITY	28 531 litres
MAX SPEED	60 mile/h
WHEELS	920 DIA.
JOURNALS	140 DIA. ROLLER BEARINGS

BUFFERS	HYDRAULIC 406 DIA. HEADS
COUPLINGS	INTERNATIONAL SCREW
MIN. CURVE	31m
GEN ARRGT DRG No	-
BRAKE	AIR BLOCK, VACUUM PIPED & HAND LEVER
SUSPENSION	GLOUCESTER PEDESTAL

ISSUE 2

EX. P.O. DIAGRAM 6/814 (ALLOCATED)

46tonne GLW TANK WAGON

LOT NUMBER	

TOPS INFORMATION								
AARKND	OPERATING	OPERATING SPEED		BRAKE FORCE DATA		EXCESS LENGTH	RA (GLW)	DESIGN SHEET
CARKND	PANEL No.	60 mile/h UP TO	46 tonne GLW	12t FORCE UP TO	31tonne GLW	5	8	WI376
T T A A		mile/h ABOVE		24t FORCE ABOVE				

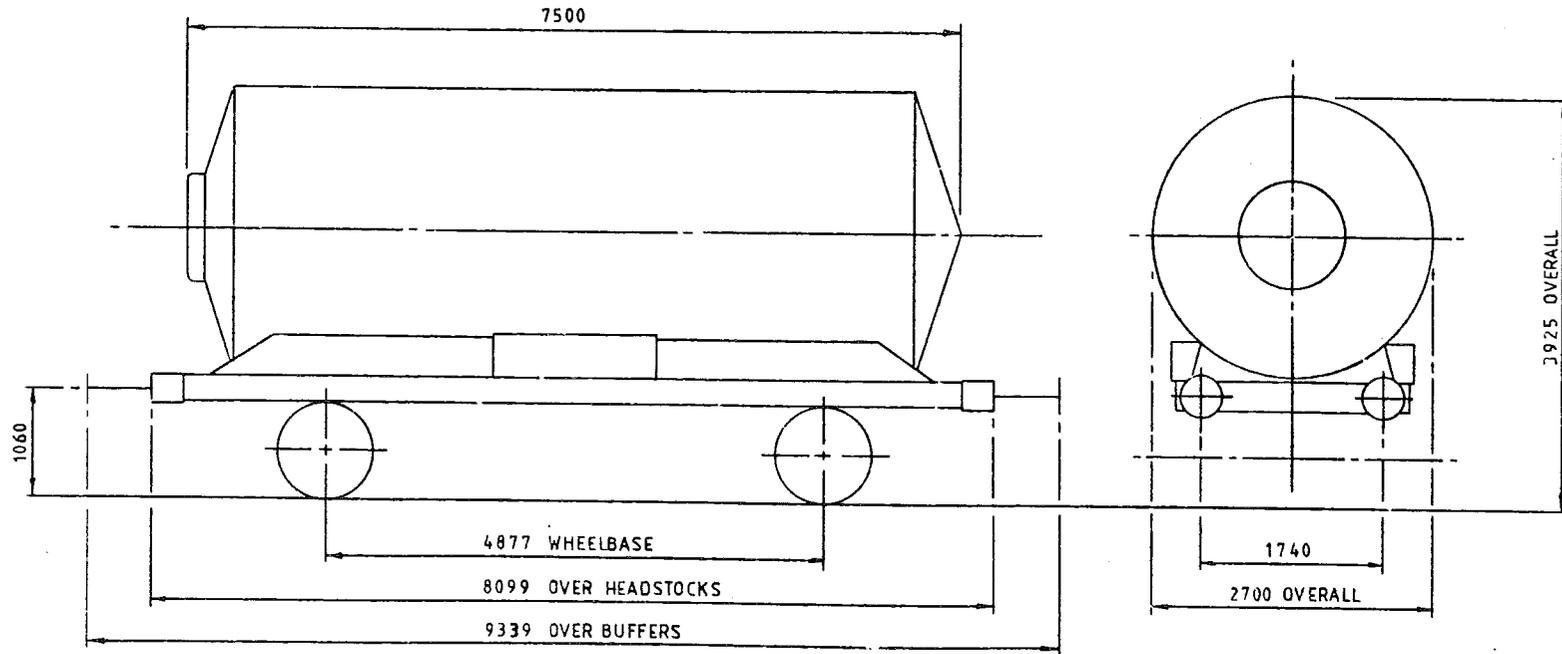

TARE-	17,500 Kg
CAPACITY, WEIGHT-	28,500 Kg
CAPACITY, VOLUME-	28,531 litres
MIN. CURVE-	31m
GEN. ARRGT. DRG. NO.-	

BRAKE-	AIR BLOCK & HAND LEVER
SUSPENSION-	GLOUCESTER PEDESTAL
COUPLINGS-	INTERNATIONAL SCREW
BUFFERS-	HYDRAULIC 406 DIA HEADS
WHEELS-	920 DIA.
JOURNALS-	140 DIA. ROLLER BEARINGS

ISSUE 1

46tonne GLW TANK WAGON

LOT NUMBER	

TOPS INFORMATION									
AARKND	OPERATING		OPERATING SPEED		BRAKE FORCE DATA		EXCESS LENGTH	RA (GLW)	DESIGN SHEET
CARKND	PANEL No.		60mile/h UP TO	46 tonne GLW	12t FORCE UP TO	31tonne GLW			
T	T	A	A						
							5	8	W1512

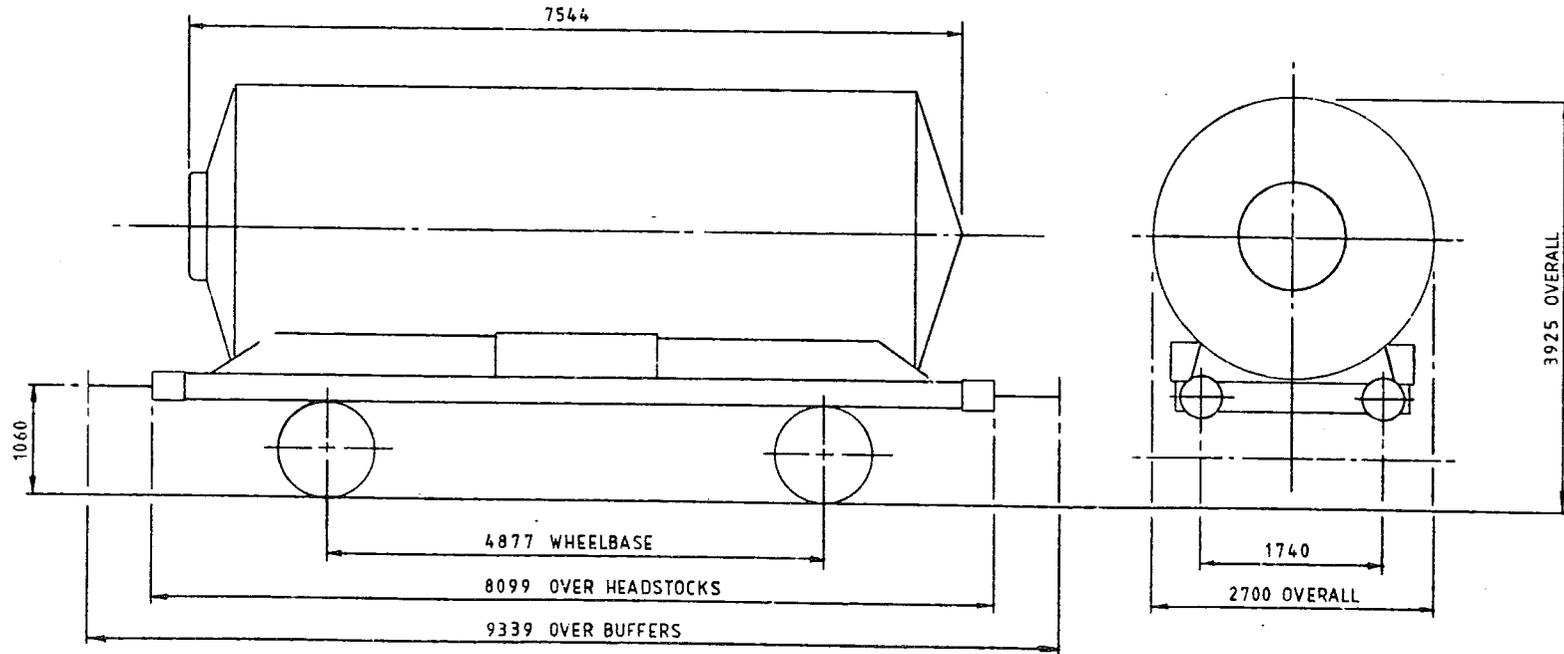

TARE-	17,500 Kg
CAPACITY, WEIGHT-	28,500 Kg
CAPACITY, VOLUME-	28,531 litres
MIN. CURVE-	31m
GEN. ARRGT. DRG. NO.-	

BRAKE-	AIR BLOCK & HAND LEVER
SUSPENSION-	GLOUCESTER PEDESTAL
COUPLINGS-	INTERNATIONAL SCREW
BUFFERS-	HYDRAULIC 406 DIA. HEADS
WHEELS-	920 DIA.
JOURNALS-	140 DIA. ROLLER BEARINGS

ISSUE 1

46 tonne GLW TANK WAGON

LOT NUMBER	

TOPS INFORMATION										
AARKND		OPERATING		OPERATING SPEED		BRAKE FORCE DATA		EXCESS LENGTH	RA (GLW)	DESIGN SHEET
CARKND	PANEL No.	60 mile/h UP TO		46 tonne GLW		0.375 + (0.5 * tonnes)		6	8	W780
T T B	A									

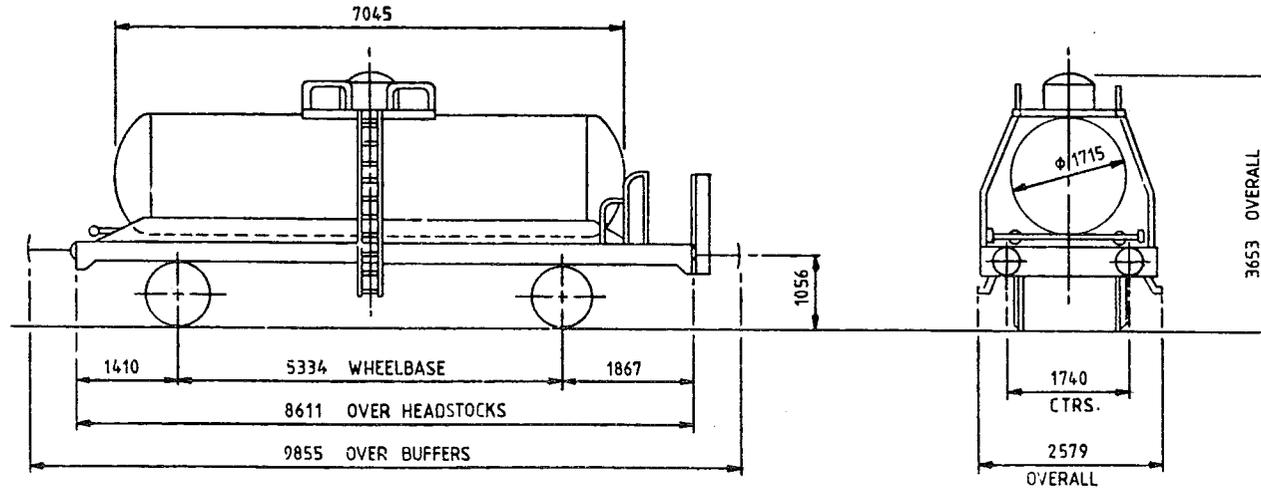

TARE-	16.800 Kg
CAPACITY, WEIGHT-	29,200 Kg
CAPACITY, VOLUME-	13,300 litres
MIN. CURVE-	36 m
GEN. ARRGT. DRG. NO.-	682909/OI-C.ROBERTS

BRAKE-	AIR BLOCK, THROUGH VAC PIPE & HAND LEVER & SCREW
SUSPENSION-	
COUPLINGS-	
BUFFERS-	
WHEELS-	952 DIA.
JOURNALS-	

ISSUE 1

46 tonne GLW TANK WAGON

LOT NUMBER	

TOPS INFORMATION										
AARKND	OPERATING	OPERATING SPEED			BRAKE FORCE DATA		EXCESS LENGTH	RA (GLW)	DESIGN SHEET	
CARKND	PANEL No.	60 mile/h UP TO			46 tonne GLW		0.375 +(0.5 x tonnes)	6	8	W 780
T T A	A	mile/h ABOVE								

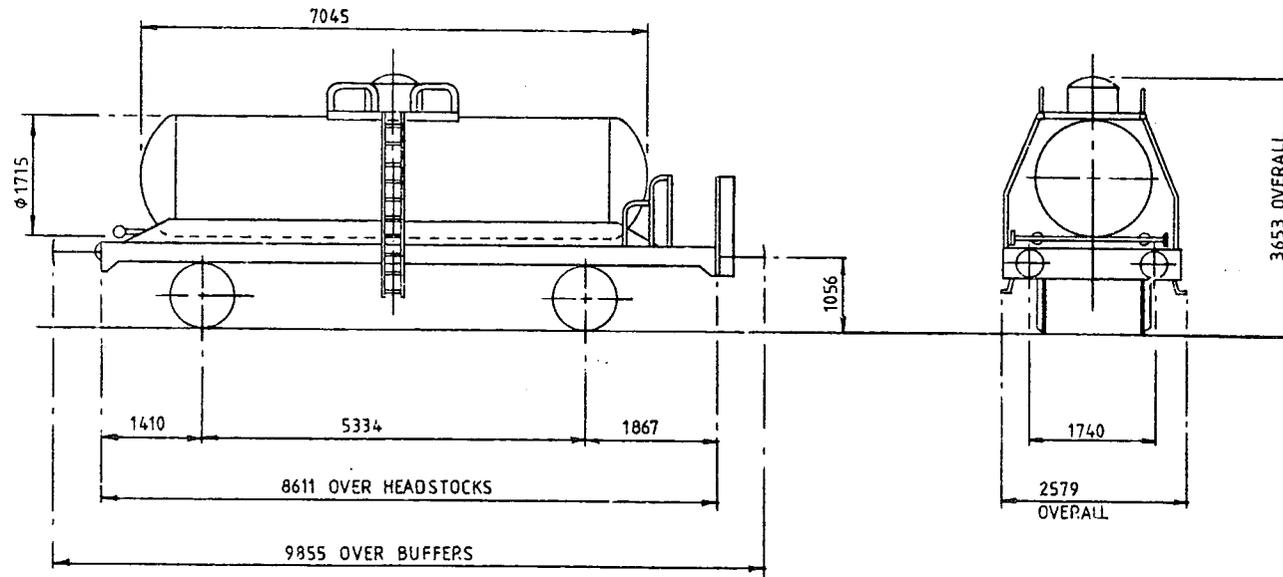

TARE-	16,800 Kg
CAPACITY, WEIGHT-	29,200 Kg
CAPACITY, VOLUME-	13,300 litres
MIN. CURVE-	36 m
GEN. ARRGT. DRG. NO.-	682909/01

BRAKE-	AIR BLOCK & HAND LEVER
SUSPENSION-	
COUPLINGS-	
BUFFERS-	
WHEELS-	952 DIA
JOURNALS-	

ISSUE 1

46 tonnes G.L.W. TANK WAGON. CLASS B.

TTO76A

EXCESS LENGTH	5	H	M	L	E
tonnes	46	46	15	15	
VB					
AB	22	22	10	10	
RA	8	8	1	1	
MAX. SPEED	60	60	45	45	

TOPS CODE										
CARKND			AARKND			OPERATING PANEL No.				
T	T	A	T	T	A	A	I	5	3	3

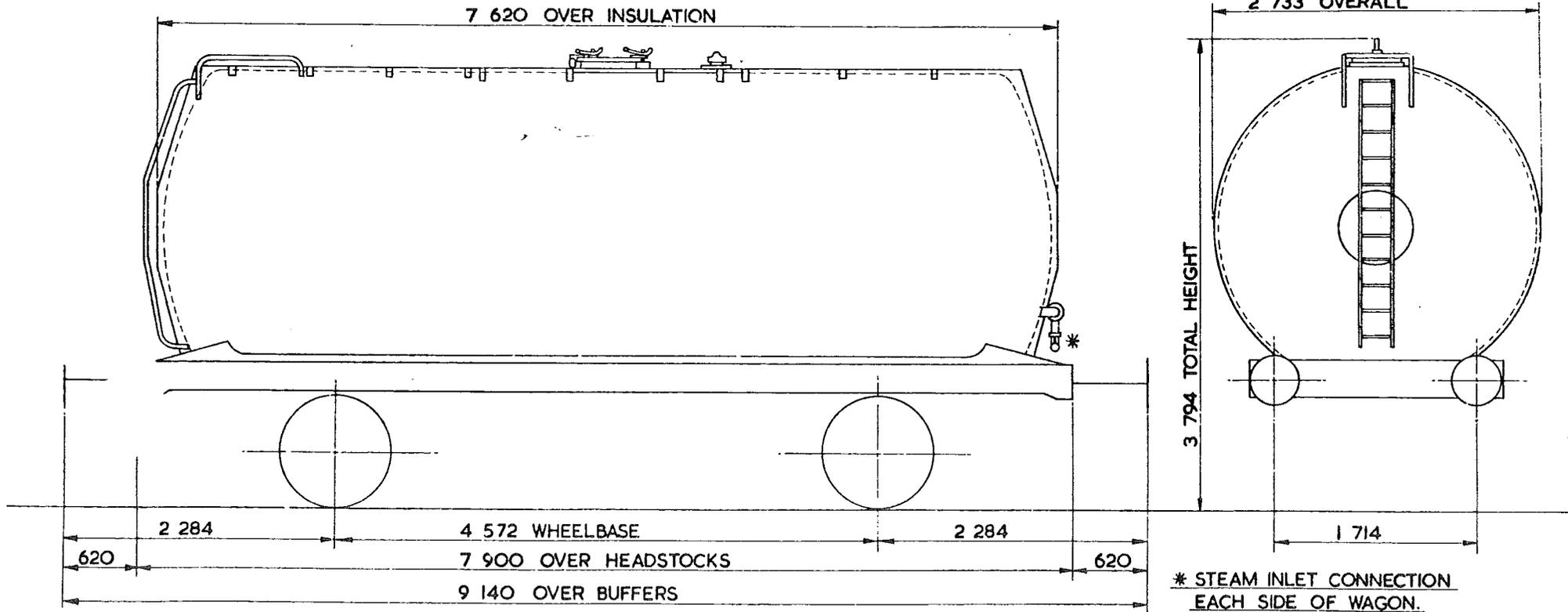

TARE -	13 ⁸⁰⁰ kg
CARRYING CAPACITY -	32 ²⁰⁰ kg
CAPACITY -	39 914 litres
MAX. SPEED -	60 mile/h
WHEELS -	952 DIA.
JOURNALS -	140 DIA. ROLLER BEARINGS

BUFFERS -	HYDRAULIC 406 DIA. HEADS
COUPLINGS -	INTERNATIONAL SCREW
MIN. CURVE -	51m
GEN ARRGT DRG. No. -	
BRAKE -	AIR BLOCK & HAND LEVER.
SUSPENSION -	DOUBLE LINK

BUILDER -	POWELL DUFFRYN & RY. PICKERING.
OWNER -	B.R.T. & E.
REGISTERED BY -	WESTERN REGION
YEAR BUILT -	1966/67 MODIFIED 1975
REGISTRATION Nos. -	57377 - 57570 (RANGE).
OWNERS Nos. -	

ISSUE 1

EX PO DIAGRAM 6/227 (ALLOCATED).

46 tonne GLW TANK WAGON CLASS B - BITUMEN

TT076B

EXCESS LENGTH	4	H	M	L	E
tonnes	46	46	14	14	
vB					
AB	22	22	10	10	
RA	8	8	1	1	
MAX SPEED	60	60	60	60	

TOPS CODE		
CARKND	AARKND	OPERATION
T	T	A
T	T	A
A	A	1 5 8 5

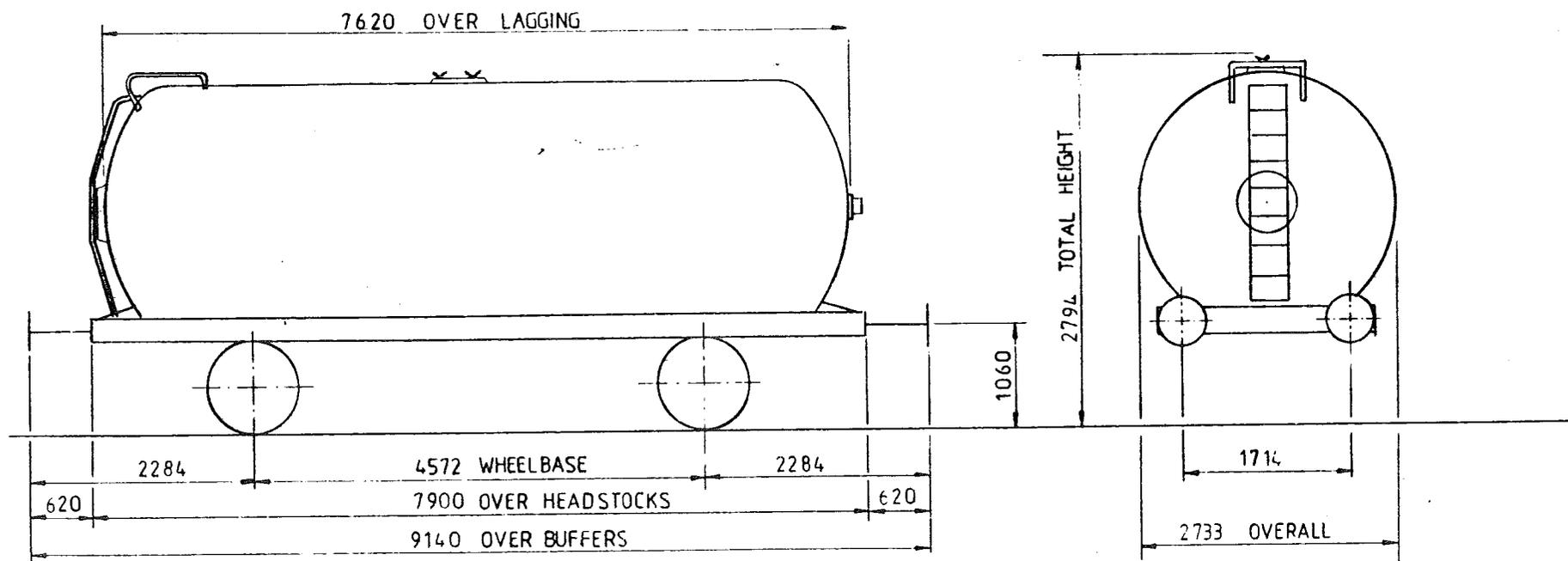

TARE	13500 kg
CARRYING CAPACITY -	32000 kg
CAPACITY -	39914 Litres
MAX SPEED	60 mile/h
WHEELS	φ 952
JOURNALS	φ 140 ROLLER BEARINGS

BUFFER	HYDRAULIC φ 406 HEADS
COUPLINGS	INTERNATIONAL SCREW
MIN CURVE	51m
GEN ARRGT DRG No.	
BRAKE	AIR BLOCK, HAND LEVER
SUSPENSION	DOUBLE LINK & BRUNINGHAUS SPRINGS

ISSUE 1

EX PO. DIAGRAM 6/227 (ALLOCATED)

46 tonne GLW TANK WAGON CLASS B FUELS

TT076C

EXCESS LENGTH	4	H	M	L	E
tonnes	46	46	13	13	
VB					
AB	22	22	10	10	
RA	8	8	1	1	
MAX SPEED	60	60	60	60	

TOPS CODE									
CARKND		AARKND			OPERATION POINT				
T	T	A	T	A	A	1	5	8	5

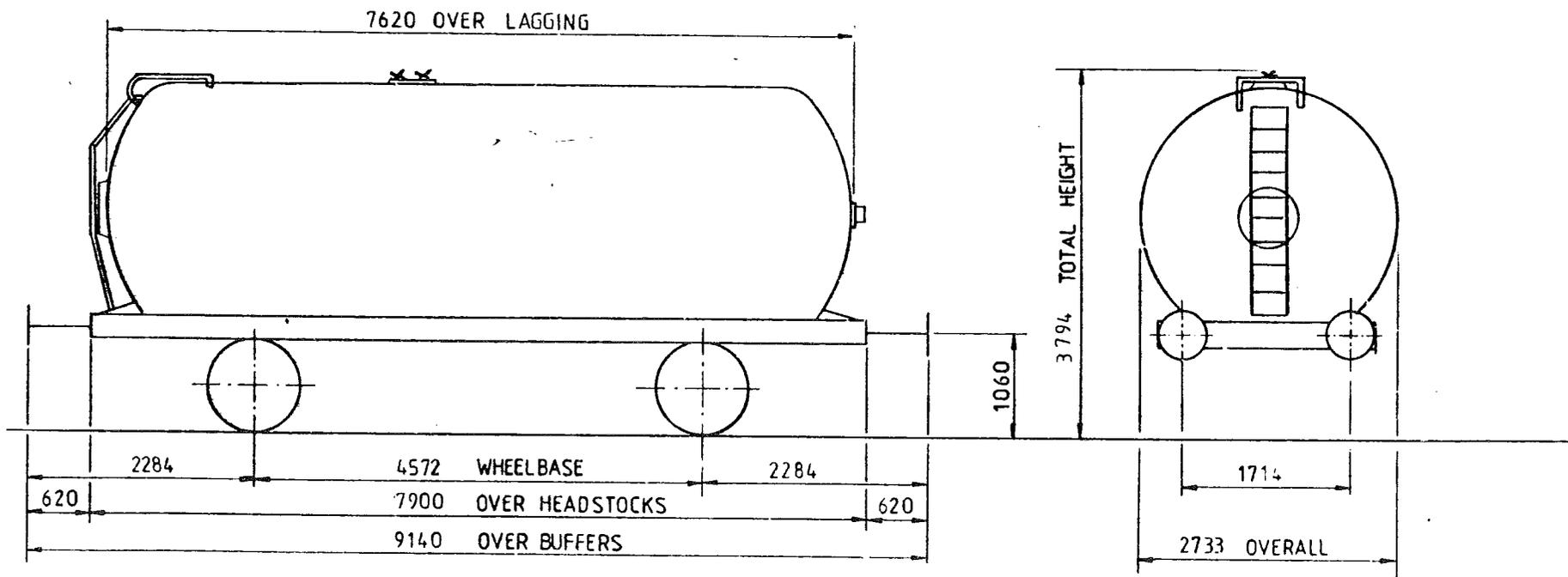

TARE	13000	kg
CARRYING CAPACITY -	33000	kg
CAPACITY -	39914	Litres
MAX SPEED	60	mile/h
WHEELS	φ 952	
JOURNALS	φ 140	ROLLER BEARINGS

BUFFERS	HYDRAULIC	φ 406	HEADS
COUPLINGS	INTERNATIONAL SCREW		
MIN CURVE	51m		
GEN ARRGT DRG No			
BRAKE	AIR BLOCK,	HAND LEVER	
SUSPENSION	FAT 26		

ISSUE 1

EX PO. DIAGRAM 6/227 (ALLOCATED)

46 tonnes G.L.W. TANK WAGON - CLASS A

TT 077A

EXCESS LENGTH	5	H	M	L	E
tonnes	46	46	13	13	
VB					
AB	26	26	7	7	
RA	8	8	1	1	
MAX. SPEED	60	60	60	60	

TOPS CODE									
CARKND	AARKND			OPERATING PANEL No.					
T	T	A	T	A	A	1	2	1	9

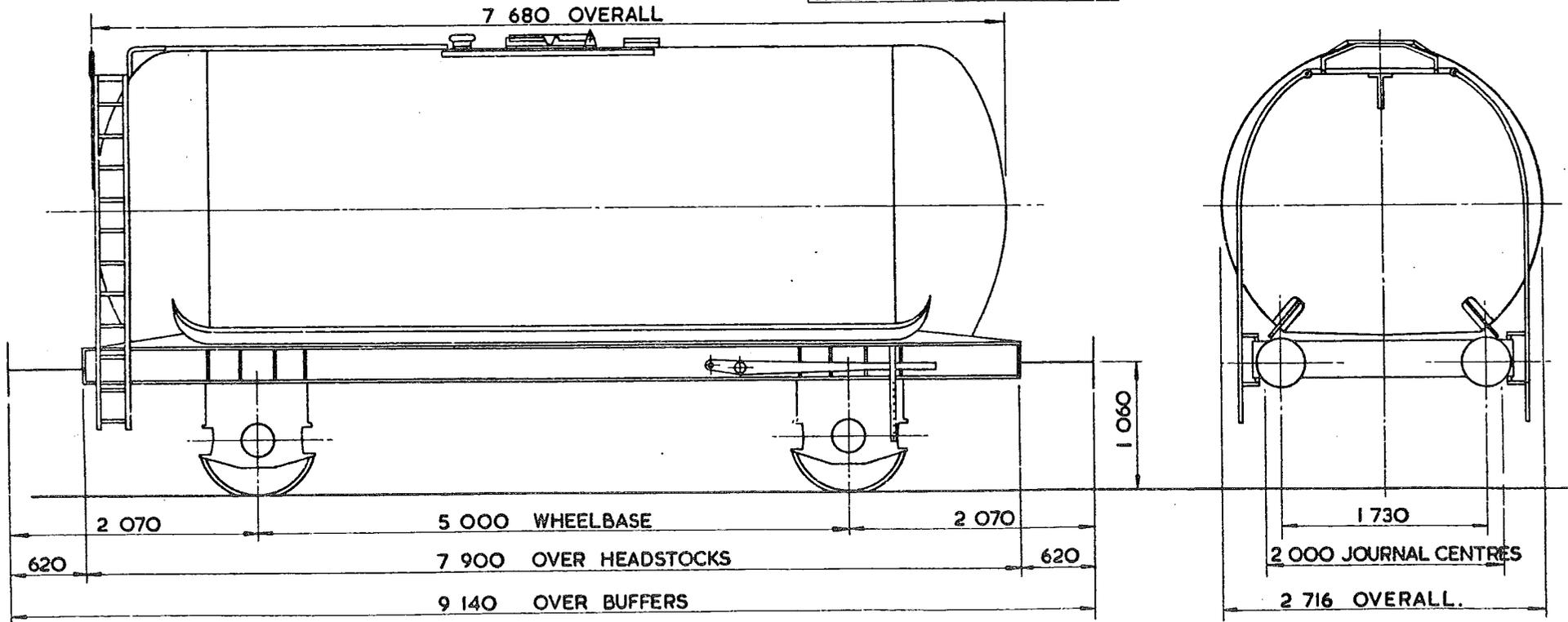

TARE-	13200kg
CARRYING CAPACITY-	32 800 kg
CAPACITY-	40 460 litres
MAX. SPEED-	60 mile / h
WHEELS-	952 DIA.
JOURNALS-	150 DIA. ROLLER BEARINGS

BUFFERS-	HYDRAULIC 406 DIA HEADS
COUPLINGS-	INTERNATIONAL SCREW
MIN. CURVE-	31 m.
GEN. ARRGT. DRG. No.-	
BRAKE-	AIR BLOCK & HAND LEVER
SUSPENSION-	GLOUCESTER PEDESTAL

BUILDER-	STANDARD RAILWAY WAGON CO. LTD.
OWNER-	RAILEASE LTD
REGISTERED BY-	C.M. & E.E. (B.R.B.) DERBY
YEAR BUILT-	1976
REGISTRATION Nos.-	55500 - 55509
OWNERS Nos.-	

ISSUE 2.

EX. P.O. DIAGRAM 6/348 (ALLOCATED)

46 tonnes G.L.W. TANK WAGON - CLASS A

TTO77B

LOT NUMBER	

TOPS INFORMATION								
AARKND	OPERATING	OPERATING SPEED		BRAKE FORCE DATA		EXCESS LENGTH	RA (GLW)	DESIGN SHEET
CARKND	PANEL No.	60 mile/h UP TO	46 tonne GLW	7t FORCE UP TO	31 tonne G.L.W.	5	8	
T T A A		-mile/h ABOVE-		26t FORCE ABOVE				

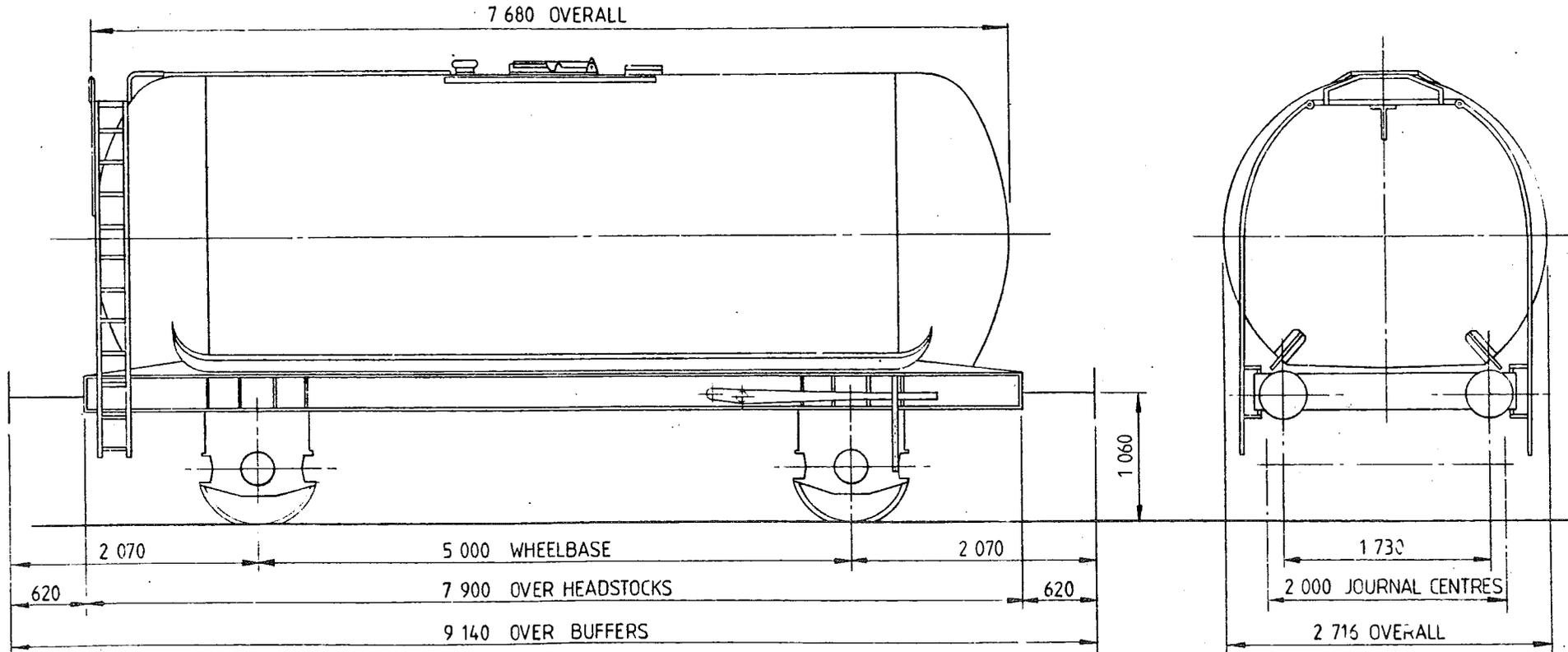

TARE-	13 200kg
CAPACITY, WEIGHT-	32 800kg
CAPACITY, VOLUME-	
MIN. CURVE-	31m
GEN. ARRGT. DRG. NO.-	

BRAKE-	AIR BLOCK & HAND LEVER
SUSPENSION-	GLOUCESTER PEDESTAL
COUPLINGS-	INTERNATIONAL SCREW
BUFFERS-	HYDRAULIC 406 DIA. HEADS
WHEELS-	952 DIA.
JOURNALS-	150 DIA ROLLER BEARINGS

ISSUE 1
EX. P.O DIAGRAM No. 6/348 (ALSO DATED)

46 tonnes G.L.W. NITRIC ACID TANK WAGON.

TT 078A

EXCESS LENGTH	H	M	L	E
tonnes	46	46	14	14
VB	0	0	0	0
AB	25	25	9	9
RA	8	5	2	1
MAX SPEED	60	60	60	60

TOPS CODE										
CARKND		AARKND		OPERATING PANEL No						
T	T	B	T	T	B	A	1	2	0	3

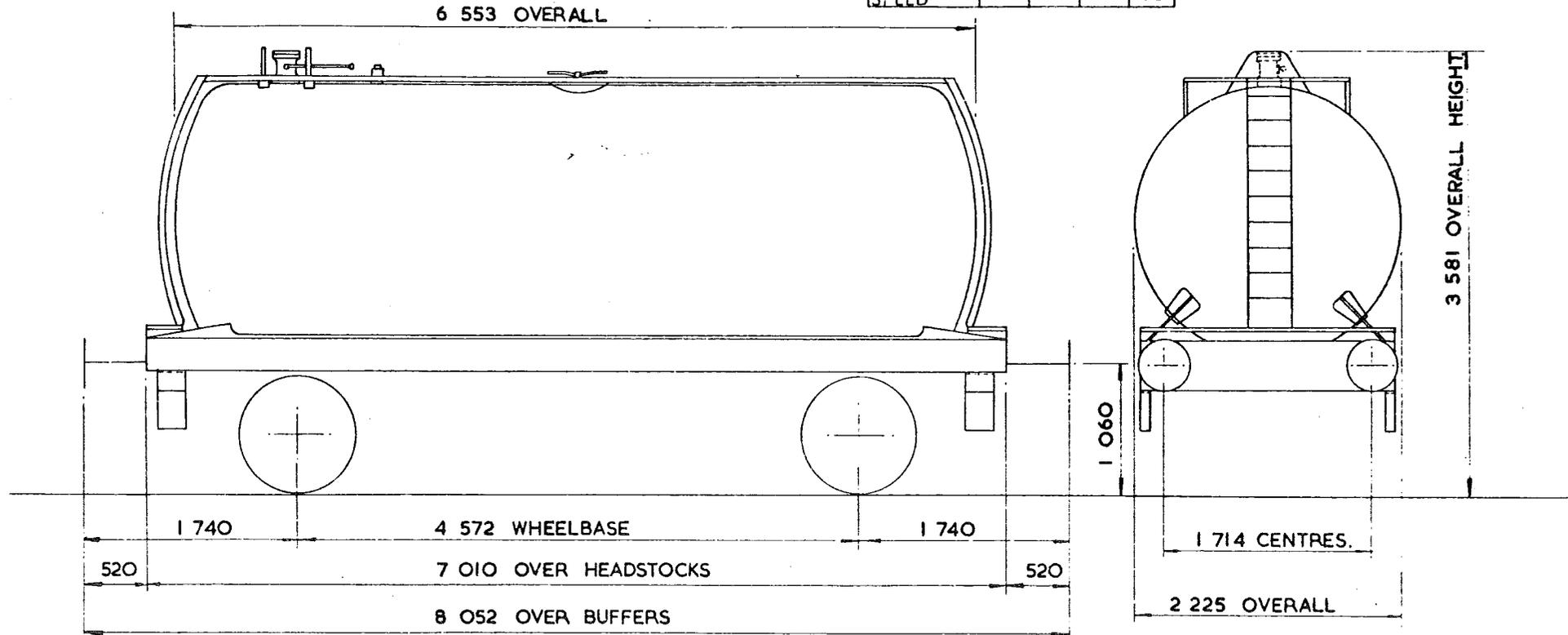

TARE --	13 700kg
CARRYING CAPACITY -	32 300kg
CAPACITY -	23 794 litres.
MAX. SPEED	60 mlie/h.
WHEELS --	952DIA.
JOURNALS	140 DIA. ROLLER BEARINGS.

BUFFERS --	HYDRAULIC 406 DIA. HEADS.
COUPLINGS --	INSTANTER.
MIN. CURVE --	51m.
GEN ARRG. DRG. No. --	
BRAKE --	AIR BLOCK, VACUUM PIPED & HAND LEVER
SUSPENSION --	PEDESTAL.

BUILDER --	POWELL DUFFRYN.
OWNER --	M.O.D.A.
REGISTERED BY --	C.M. & E.E. (BRB) DERBY.
YEAR BUILT --	1976.
REGISTRATION Nos. --	56950 and 56951.
OWNERS Nos. --	

ISSUE 1
EX. P.O. DIAGRAM 6/249.

46 tonnes G.L.W. TANK WAGON

TT079A

DESIGN SHEET No. W.316

EXCESS LENGTH	L	H	M	L	E
tonnes	46	46	13	13	
VB					
AB	24	24	7	7	
RA	8	8	1	1	
MAX SPEED	60	60	60	60	

TOPS CODE										
CARKND		AARKND			OPERATING PANEL No.					
T	T	B	T	T	B	A	1	1	9	0

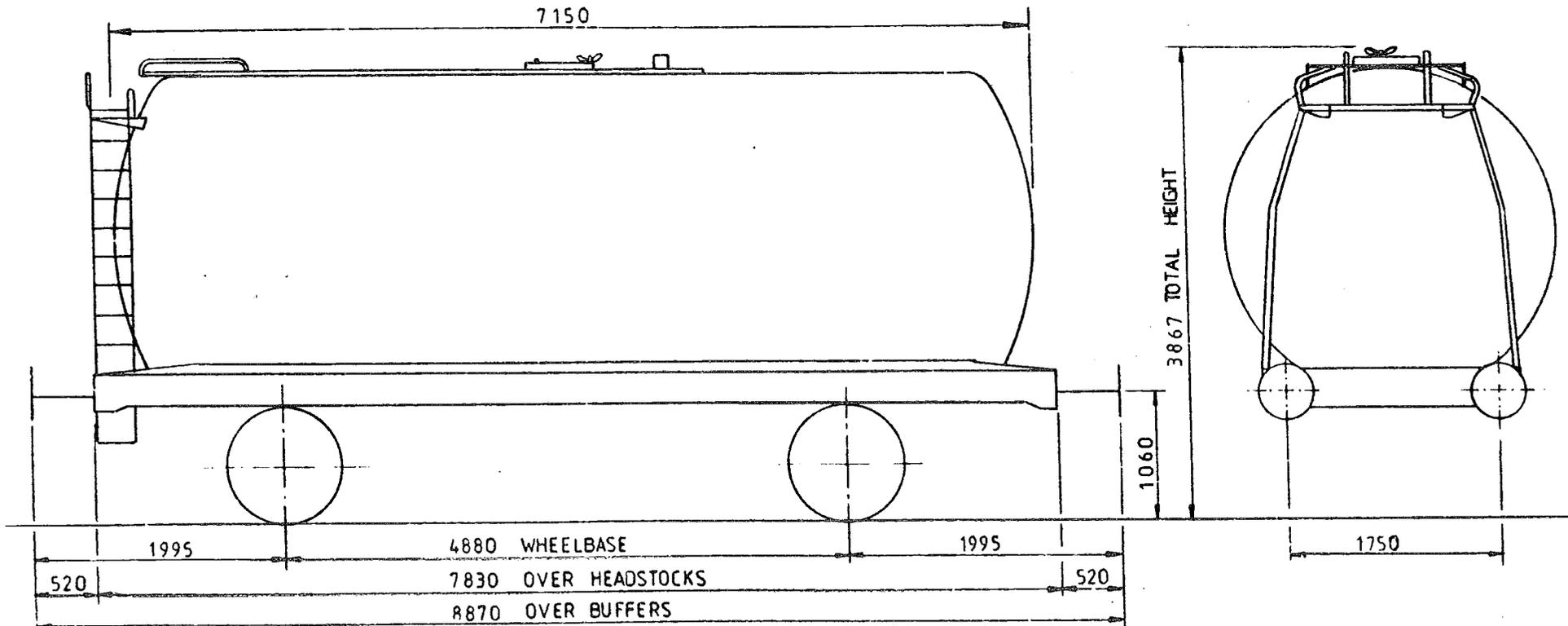

TARE -	13 200 kg
CARRYING CAPACITY -	22 850 kg
CAPACITY -	32017 Litres
MAX SPEED -	60 mile/h
WHEELS -	φ 952
JOURNALS -	φ150 ROLLER BEARINGS

BUFFERS -	HYDRAULIC φ406 HEADS
COUPLINGS -	INSTANTER
MIN CURVE -	31 m
GEN. ARRGT DRG. No. -	1. 13513.0.01. (L.H.B)
BRAKE -	AIR, BLOCK & HAND LEVER
SUSPENSION -	B.S.C. PEDESTAL

ISSUE 2.

46 tonne PHOSPHORIC ACID TANK WAGON

TT081A

EXCESS LENGTH	H	M	L	E
tonnes	46	46	13	13
VB	0	0	0	0
AB	21	17	7	7
RA	8	8	1	1
MAX SPEED	60	60	60	60

TOPS CODE									
CARKND			AARKND			OPERATING PANEL No			
T	T	B	T	T	B	A	8	8	4

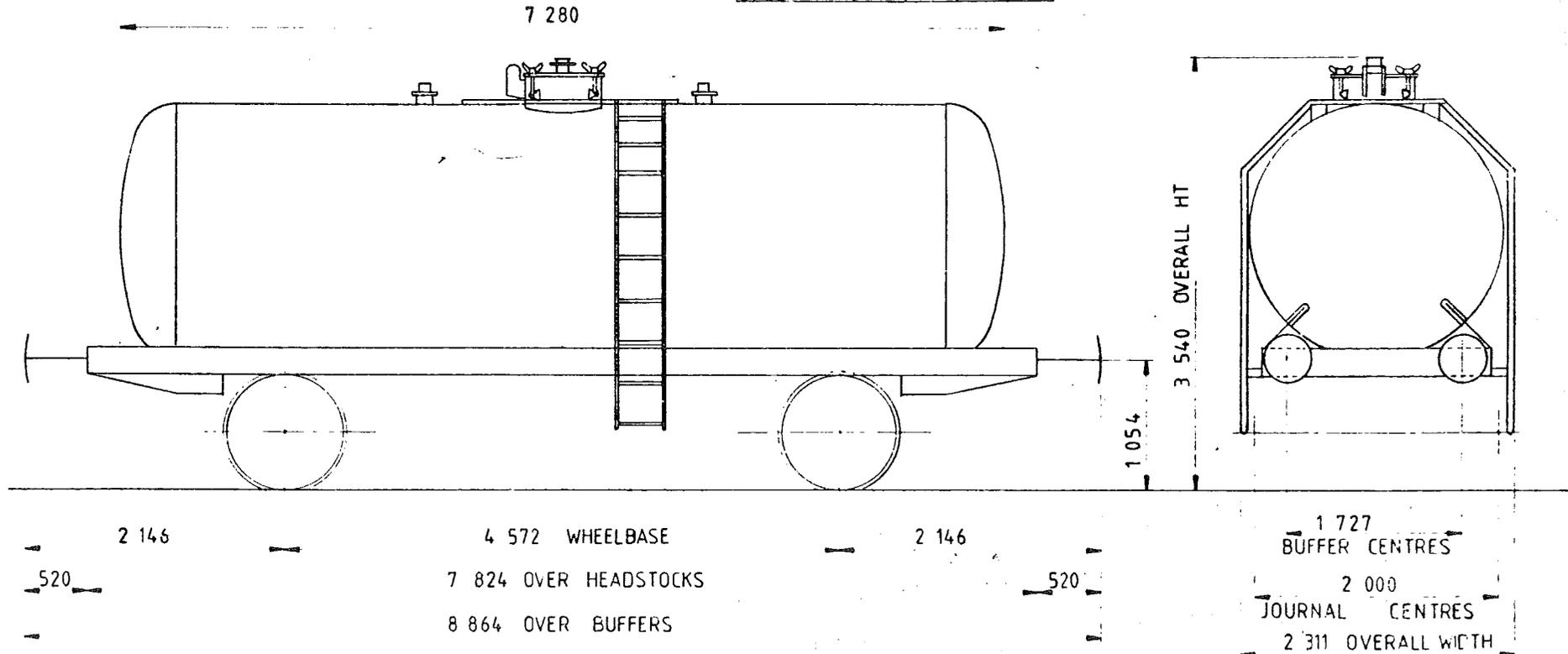

TARE - 12450 kg.
CARRYING CAPACITY - 33500 kg.
CAPACITY - 22167 litres.
MAX SPEED - 60 mph
WHEELS - 952 DIA
JOURNALS - 150 DIA ROLLER BEARINGS

BUFFERS HYDRAULIC 406 DIA HEADS
COUPLINGS INSTANTER
MIN CURVE 31m SINGLY & CLOSE COUPLED
GEN ARRGT. DRG No. -
BRAKE - AIR BLOCK THROUGH VACUUM PIPE
SUSPENSION - B.S.C. FRICTION PEDESTAL

ISSUE 1

EX P.O. DIAGRAM 61517 (ALLOCATED)

46tonne G.L.W. TANK WAGON CLASS A - CLOSE COUPLED

TT083A

EXCESS LENGTH	H	M	L	E
tonnes	46	46	15	15
VB				
AB	22	22	10	10
RA	8	8	1	1
MAX SPEED	60	60	45	45

TOPS CODE										
CARKND		AARKND			OPERATING PANEL No					
T	T	A	T	T	A	A	1	5	3	3

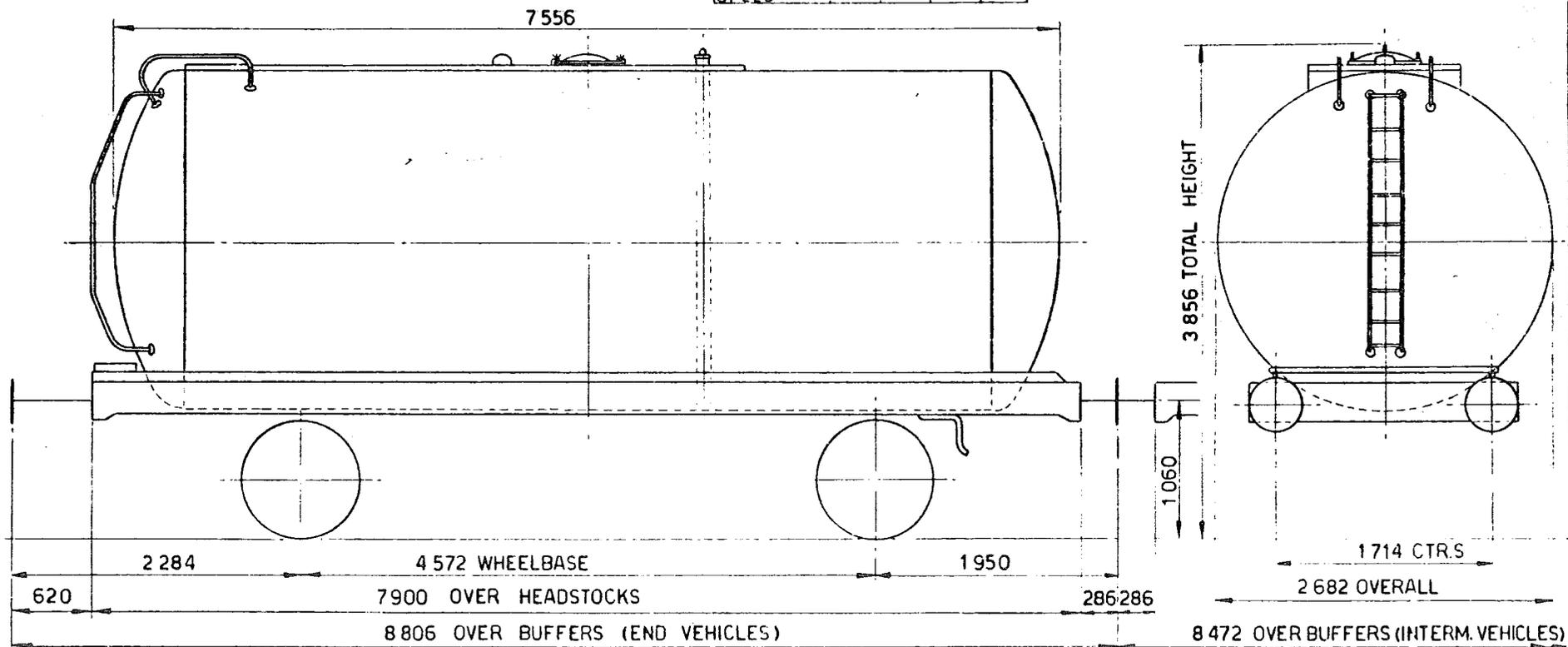

TARE - 13 ⁸⁰⁰ kg
CARRYING CAPACITY - 32 ²⁰⁰ kg
CAPACITY - 39 ⁰⁴¹ litres
MAX SPEED - 60 mile/h
WHEELS - 952 DIA.
JOURNALS - 140 ROLLER BEARING

BUFFERS HYDRAULIC 406 DIA. HEADS
COUPLINGS INTERNATIONAL SCREW, CLOSE COUPLED
MIN CURVE 31m SINGLE and CLOSE COUPLED
GEN ARRGT. DRG No -
BRAKE - AIR BLOCK and HAND LEVER
SUSPENSION - DOUBLE LINK

issue 1

46tonne G.L.W. TANK WAGON CLASS A - CLOSE COUPLED

TT083 B

EXCESS LENGTH	H	M	L	E
tonnes	46	46	14	14
VB	—	—	—	—
AB	22	22	14	14
RA	8	8	1	1
MAX. SPEED	60	60	45	45

TOPS CODE								
CARKND			AARKND			OPERATING PANEL No		
T	T	A	T	T	A	A	1	5
							4	5

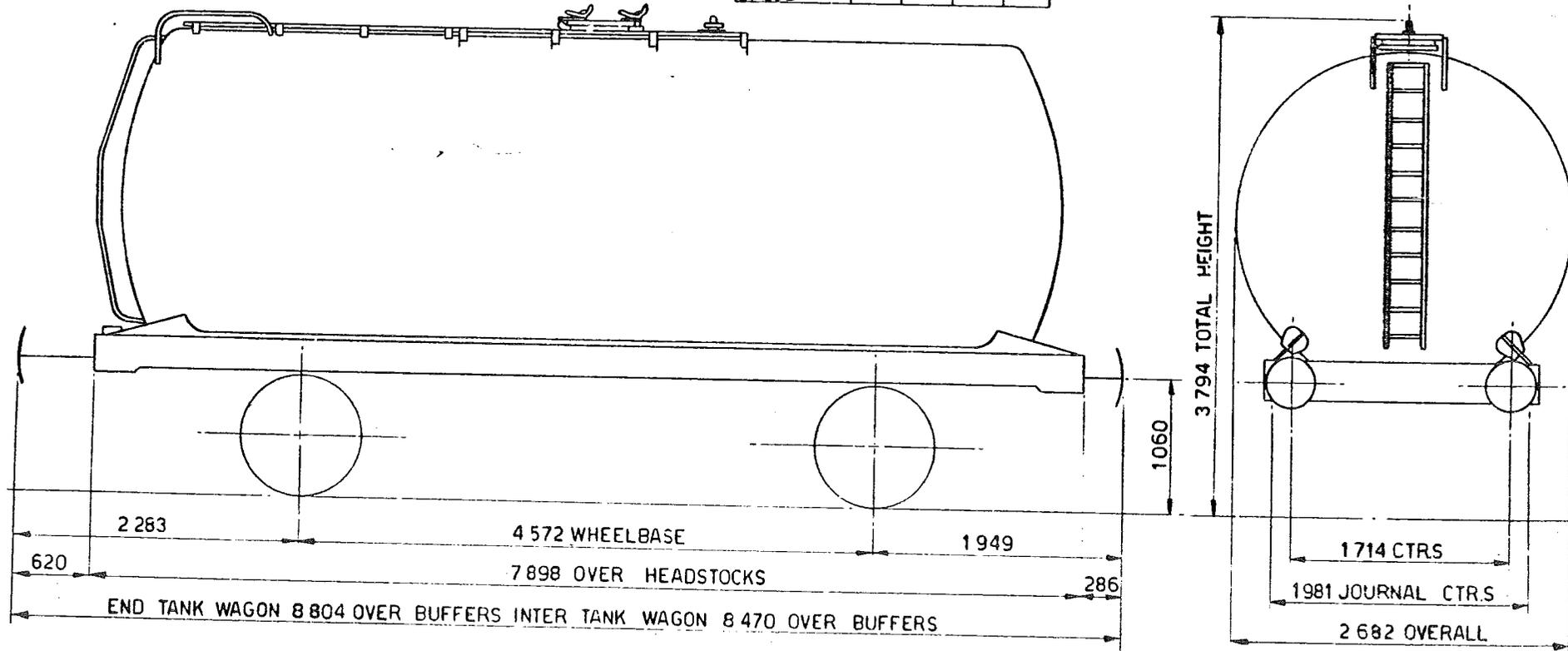

TARE - 13550kg
CARRYING CAPACITY - 32400kg
CAPACITY - 39905litres
MAX. SPEED - 60 mile/h
WHEELS - 952 DIA.
JOURNALS - 140 ROLLER BEARING

BUFFERS - HYDRAULIC 406 DIA HEADS
COUPLINGS - INTERNATIONAL SCREW, CLOSE COUPLED
MIN. CURVE - 31m SINGLE and CLOSE COUPLED
GEN ARRGT. DRG No. -
BRAKE - AIR BLOCK and HAND LEVER
SUSPENSION - DOUBLE LINK

ISSUE 1

46tonne G.L.W. TANK WAGON. CLASS .A.

TT083C

EXCESS LENGTH	H	M	L	E
tonnes	46	46	15	15
VB				
AB	22	22	10	10
RA	8	8	1	1
MAX SPEED	60	60	45	45

TOPS CODE							
CARKND	AARKND			OPERATING PANEL No			
T	T	A	T	T	A	A	1 5 3 3

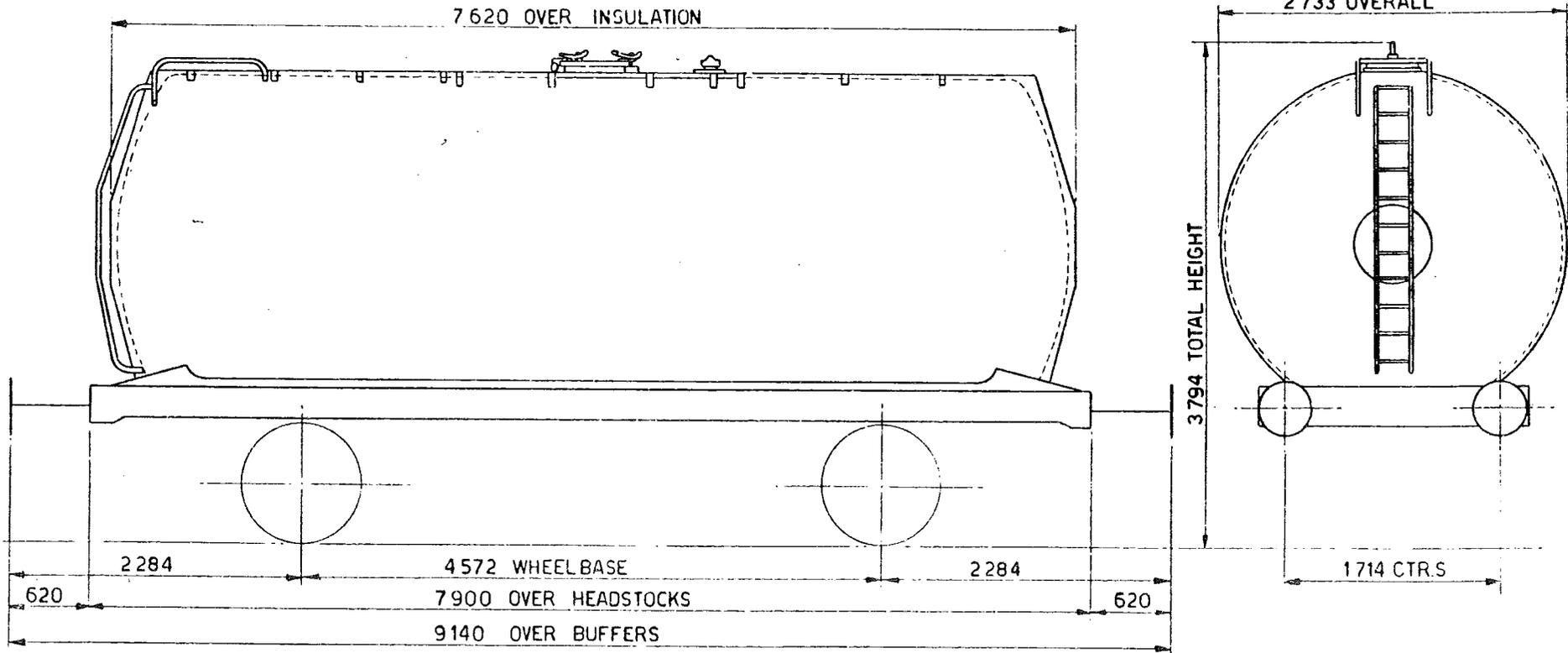

TARE -	13 ⁸⁰⁰ kg
CARRYING CAPACITY -	33 ²⁰⁰ kg
CAPACITY -	39 ⁹¹⁴ litres
MAX SPEED -	60 mile/h
WHEELS -	952 DIA.
JOURNALS -	140 ROLLER BEARING

BUFFERS	HYDRAULIC 406 DIA. HEADS
COUPLINGS	INTERNATIONAL SCREW
MIN. CURVE	51m SINGLE and CLOSE COUPLED
GEN ARRGT. DRG No.	-
BRAKE	AIR BLOCK and HAND LEVER
SUSPENSION	DOUBLE LINK

ISSUE 2

EX PO. DIAGRAM 61249

46 tonne GLW TANK WAGON LAGGED - CYCLOHEXANE

TT084A

EXCESS LENGTH	4	H	M	L	E
tonnes	46	46	16	16	
VB					
AB	23	23	11	11	
RA	8	8	1	1	
MAX SPEED	60	60	60	60	

TOPS CODE			
CARKND	AARKND
T	T	A	A 1 3 3 4

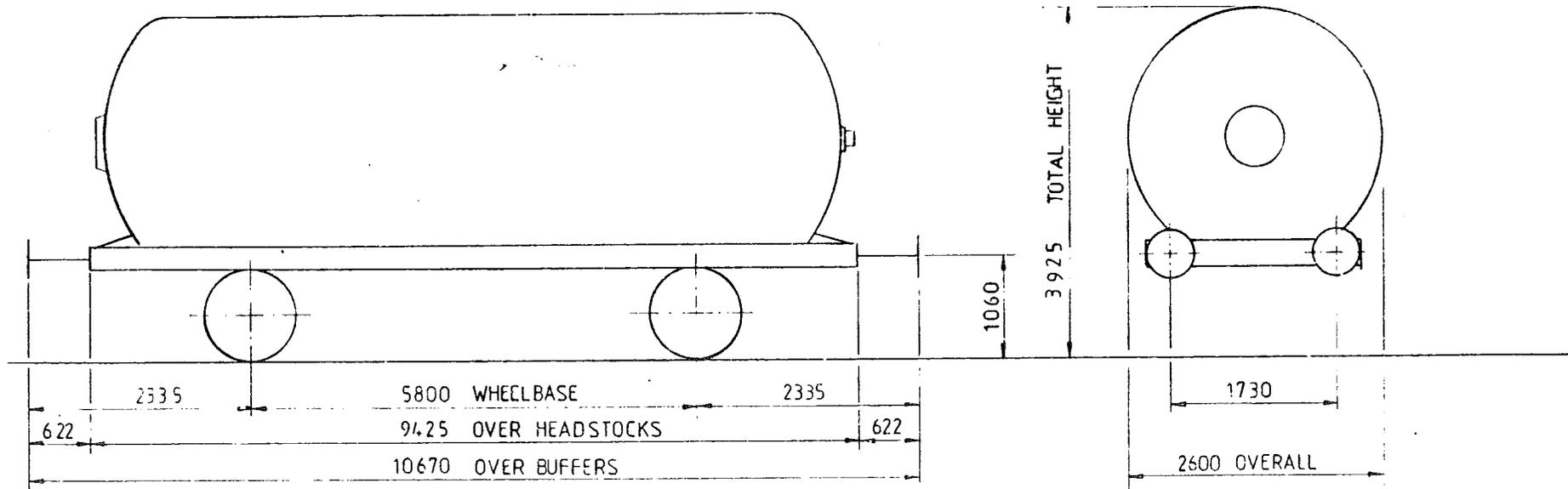

TARE	16100	kg
CARRYING CAPACITY -	29900	kg
CAPACITY -	38664	Litres
MAX SPEED	60	mile/h
WHEELS	φ 952	
JOURNALS	φ 140	ROLLER BEARINGS

BUFFERS	HYDRAULIC	φ 406	HEADS
COUPLINGS	INTERNATIONAL SCREW		
MIN CURVE	31m		
GEN ARRGT DRG NO.			
BRAKE	AIR BLOCK,	HAND LEVER	
SUSPENSION	GLOS FLOATING PEDESTAL		

ISSUE 1

46 tonne GLW TANK WAGON CLASS A

TT088A

EXCESS LENGTH	H	M	L	E
4 tonnes	46	46	14	14
VB				
AB	26	26	9	9
RA	8	8	1	1
MAX SPEED	60	60	60	60

TOPS CODE										
CARKND		AARKND			OPERATION					
T	T	A	T	T	A	A	1	5	9	1

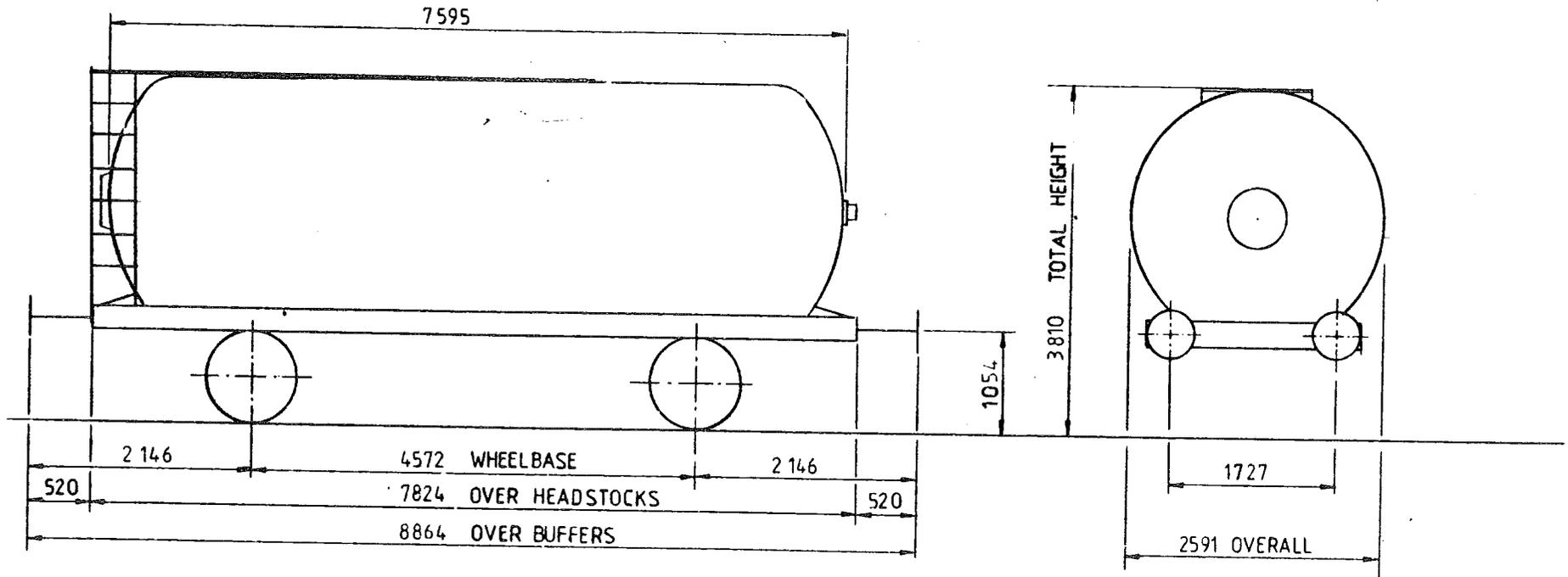

TARE -	13450 kg
CARRYING CAPACITY -	32500 kg
CAPACITY -	39532 Litres
MAX SPEED -	60 mile/h
WHEELS -	φ 952
JOURNALS -	φ 140 ROLLER BEARINGS

BUFFERS	HYDRAULIC φ 406 HEADS
COUPLINGS	INSTANTER
MIN CURVE	31m
GEN ARRGT DRG No	
BRAKE	AIR BLOCK, HAND LEVER
SUSPENSION	BRUNINGHAUS SINGLE LINK

ISSUE 1

EX PO. DIAGRAM 6/718 (ALLOCATED)

46 tonne G.L.W. TANK WAGON CLASS A

TT088E

DESIGN SHEET No. W764

EXCESS LENGTH	L	H	M	L	E
tonnes	46	46	13	13	
VB					
AB	25	25	9	9	
RA	8	8	1	1	
MAX SPEED	60	60	60	60	

TOPS CODE										
CARKND		AARKND			OPERATING PANEL No.					
T	T	A	T	T	A	A	1	5	9	3

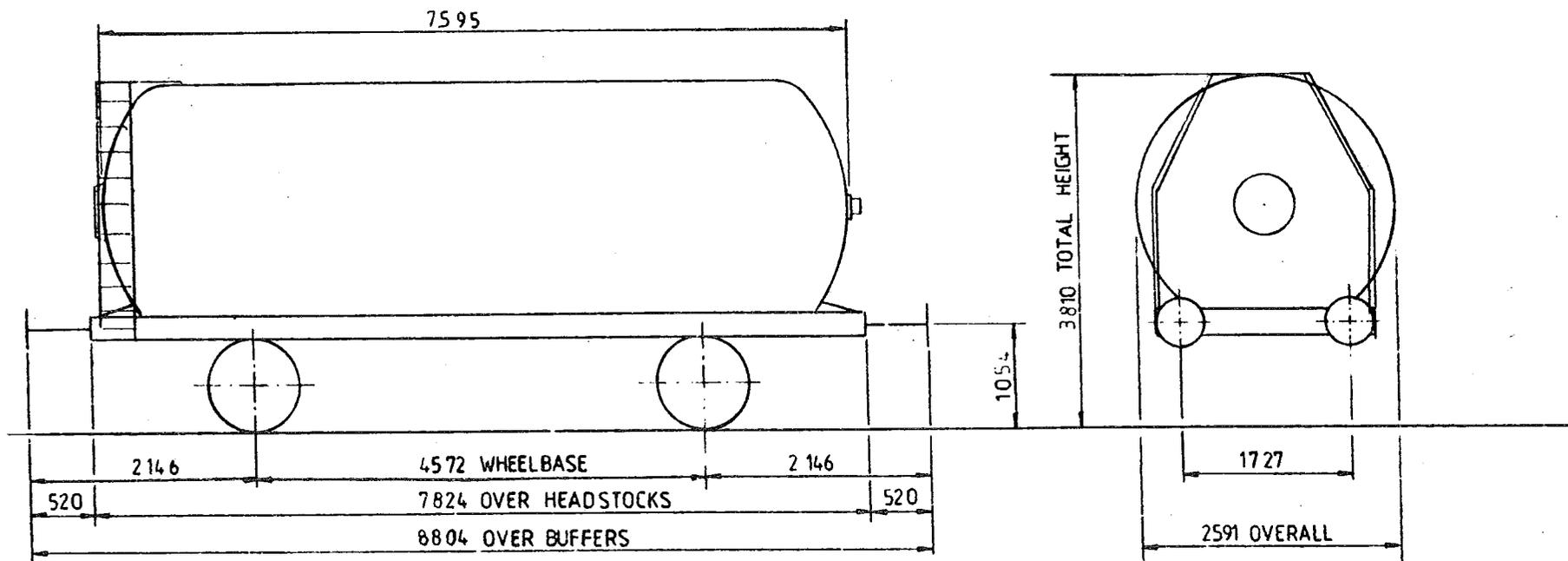

TARE -	12700	kg
CARRYING CAPACITY -	33000	kg
CAPACITY -	38468	Litres
MAX SPEED -	60	mile/h
WHEELS -	Ø 952	
JOURNALS -	Ø 140	ROLLER BEARINGS

BUFFERS -	HYDRAULIC Ø 406 HEADS
COUPLINGS -	INSTANTER
MIN CURVE -	31m
CEN ARRGT DRG No -	
BRAKE -	AIR, BLOCK & HAND LEVER
SUSPENSION -	PARABOLIC SHORT LINK

ISSUE 2.

46 tonnes G.L.W. TANK WAGON CLASS A

TT088F

EXCESS LENGTH	4	H	M	L	E
tonnes	46	46	13	13	
VB					
AB	25	25	9	9	
BA	8	8	1	1	
MAX SPEED	60	60	60	60	

TOPS CODE	
CARKND	AARKND
T T A T T A A 1 5 9 3	

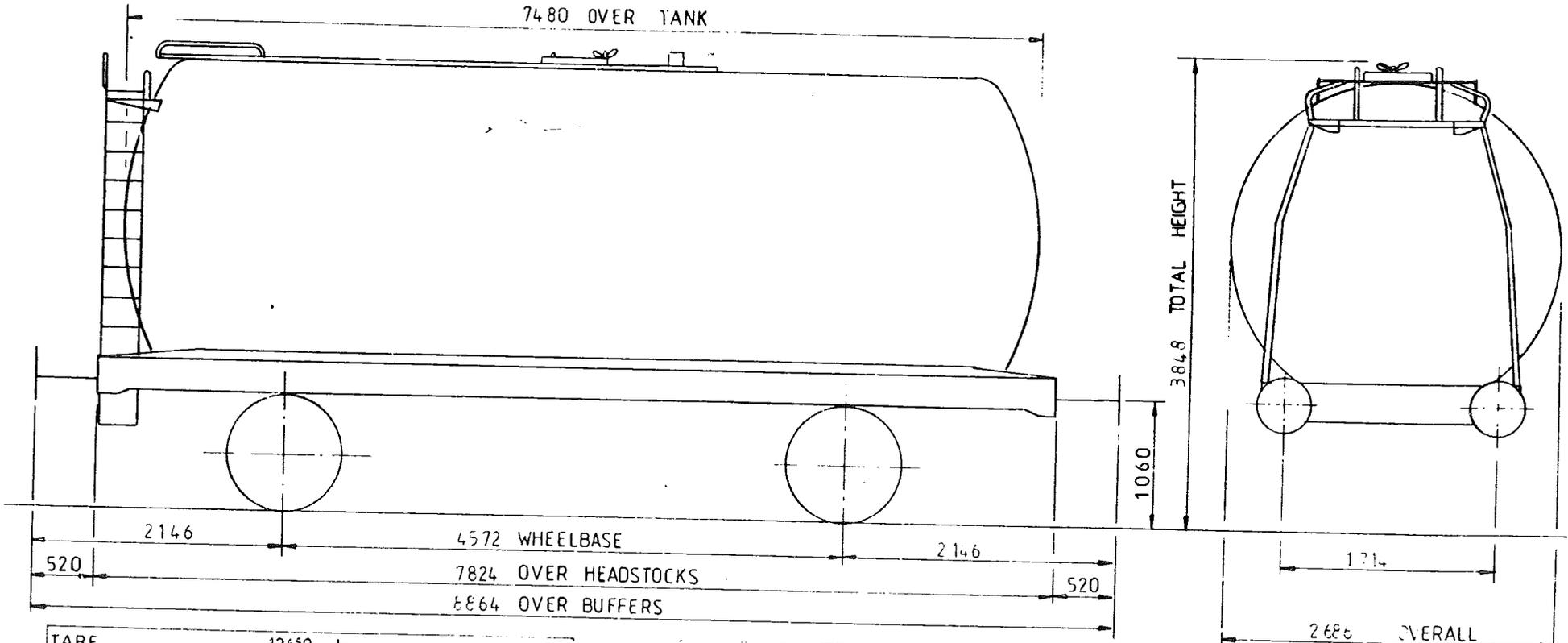

TARE	12550 kg
CARRYING CAPACITY	33200 kg
CAPACITY -	32636 Litres
MAX SPEED	60 mile/h
WHEELS	Ø 952
JOURNALS	Ø140 ROLLER BEARINGS

BUFFERS	HYDRAULIC Ø406 HEADS
COUPLINGS	INSTANTER
MIN CURVE	31 m
GEN ARRGT DRG No.	
BRAKE	AIR BLOCK HAND LEVER
SUSPENSION	PAPAEGLIC SHORT LINK

ISSUE 1

46 tonnes G.L.W. TANK WAGON CLASS A

TT 088G

EXCESS LENGTH	4	H	M	L	E
tonnes	46	46	13	13	
VB					
AB	25	25	9	9	
RA	8	8	1	1	
MAX SPEED	60	60	60	60	

TOPS CODE		
CARKND	AARKND	OPERATION PAGE
T T A	T T A A	1 5 9 3

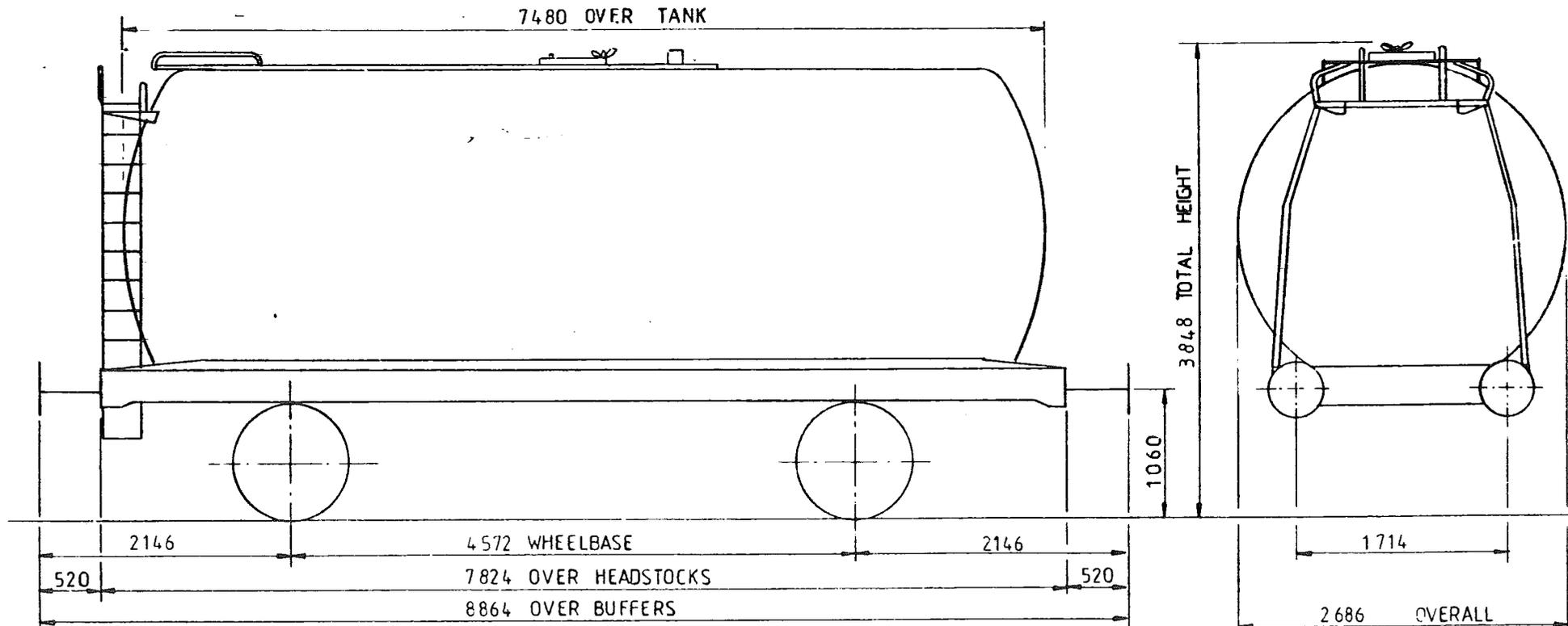

TARE	13 ¹⁵⁰ kg
CARRYING CAPACITY	33 ⁰⁰⁰ kg
CAPACITY	39436 Litres
MAX SPEED	60 mile/h
WHEELS	φ 952
JOURNALS	φ140 ROLLER BEARINGS

BUFFERS	HYDRAULIC φ406 HEADS
COUPLINGS	INSTANTER
MIN CURVE	31 m
GEN ARRGT DRG No	
BRAKE	AIR BLOCK HAND LEVER
SUSPENSION	PARABOLIC SHORT LINK

ISSUE 1

EX PO DIAGRAM 6/716 (ALLOCATED)

46 tonnes GLW. TANK WAGON CLASS A

TT088H

EXCESS LENGTH	4	H	M	L	E
tonnes	46	46	13	13	
VB					
AB	25	25	9	9	
BA	8	8	1	1	
MAX SPEED	60	60	60	60	

TOPS CODE		
CARKND	AARKND	***** PAGE 1
T T A T T A A	1 5 9 3	

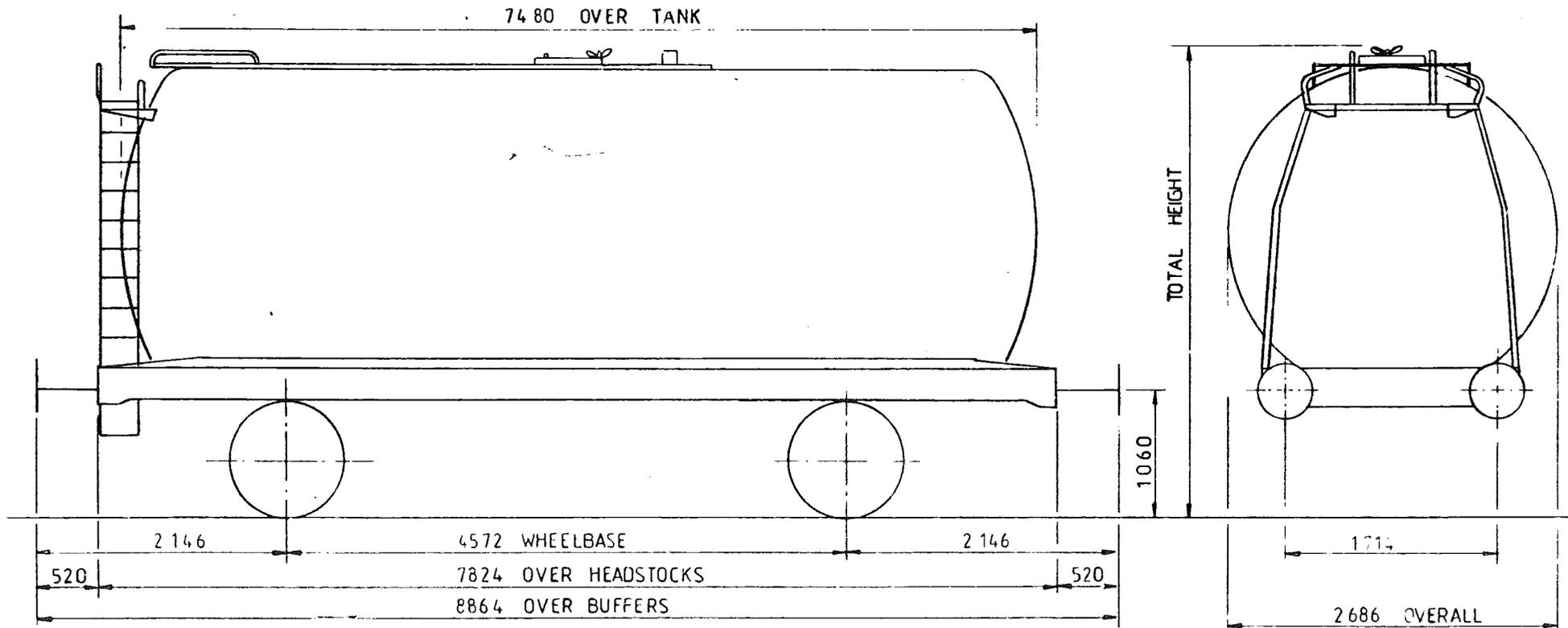

TARE	13 ⁰⁰⁰ kg
CARRYING CAPACITY	33 ⁰⁰⁰ kg
CAPACITY	39277 Litres
MAX SPEED	60 mile/h
WHEELS	φ 952
JOURNALS	φ140 ROLLER BEARINGS

BUFFERS	HYDRAULIC φ406 HEADS
COUPLINGS	INSTANTER
MIN CUR.F	31 m
GEN ARRGT DRG NO	
BRAKE	AIR BLOCK HAND LEVER
SUSPENSION	PARABOLIC SHORT LINK

ISSUE 1

EX PO DIAGRAM 6/159 (ALLOCATED)

46 tonne GLW TANK WAGON-CLASS 'B'

LOT NUMBER	

TOPS INFORMATION									
AARKND	OPERATING		OPERATING SPEED		BRAKE FORCE DATA		EXCESS LENGTH	RA (GLW)	DESIGN SHEET
CARKND	PANEL No.		60 mile/h UP TO mile/h ABOVE 46 tonne GLW		7t FORCE UP TO 24.5tonne GLW 21t FORCE ABOVE				
T T A A							4	9	W761 W1027

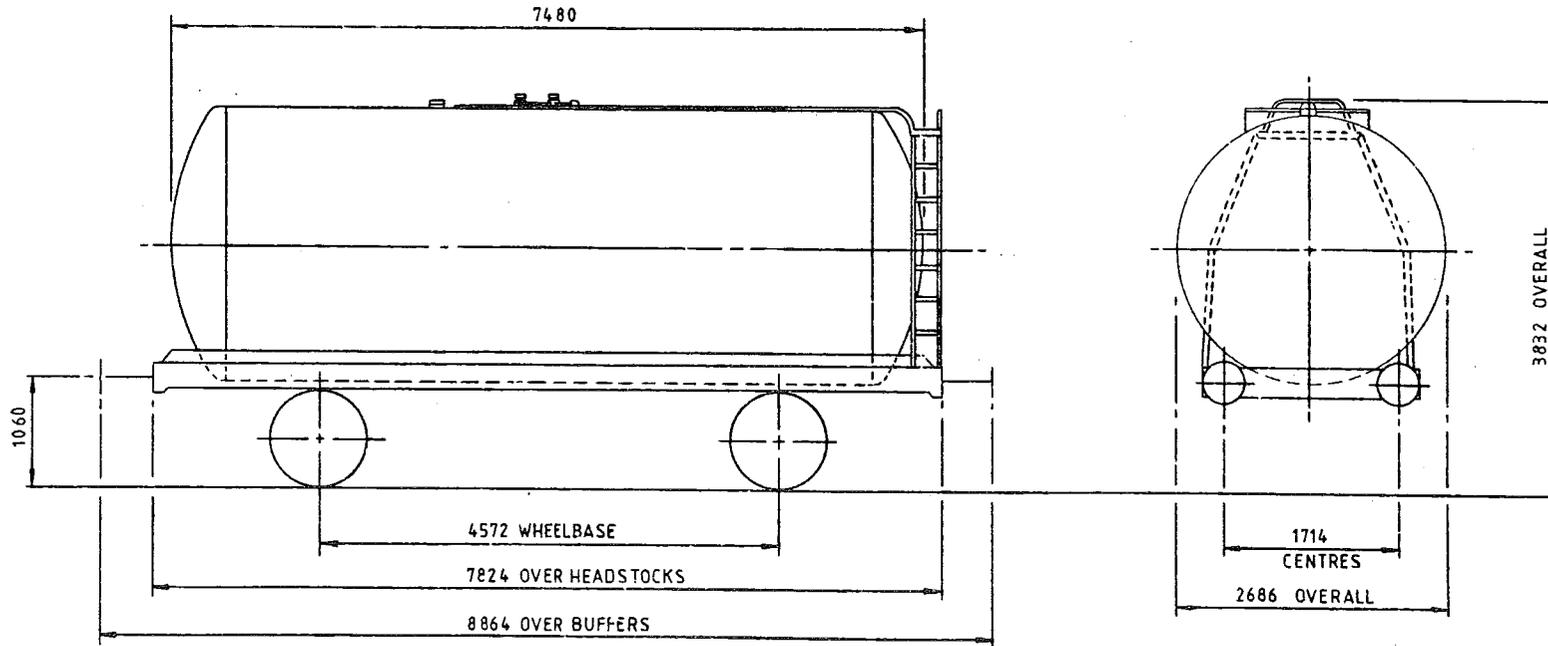

TARE-	13,000 Kg
CAPACITY, WEIGHT-	33,000 Kg
CAPACITY, VOLUME-PETROL	38.154 KERO-GAS OIL 38.745
MIN. CURVE-	31m
GEN. ARRGT. DRG. NO.-	

BRAKE-	AIR BLOCK & HAND LEVER
SUSPENSION-	DOUBLE LINK & PARABOLIC SPRING
COUPLINGS-	INSTANTER
BUFFERS-	HYDRAULIC 406 DIA. HEADS
WHEELS-	952 DIA.
JOURNALS-	140 DIA. ROLLER BEARINGS

ISSUE 2

46 tonne GLW TANK WAGON CLASS B

TT088L

EXCESS LENGTH	4	H	M	L	E
tonnes	46	46	13	13	
VB					
AB	21	21	7	7	
RA	8	8	1	1	
MAY SPEED	60	60	60	60	

TOPS CODE				
CARKND	AARKND	OPERATION	PARTS	
T	T	A	A	A
1	6	1	5	

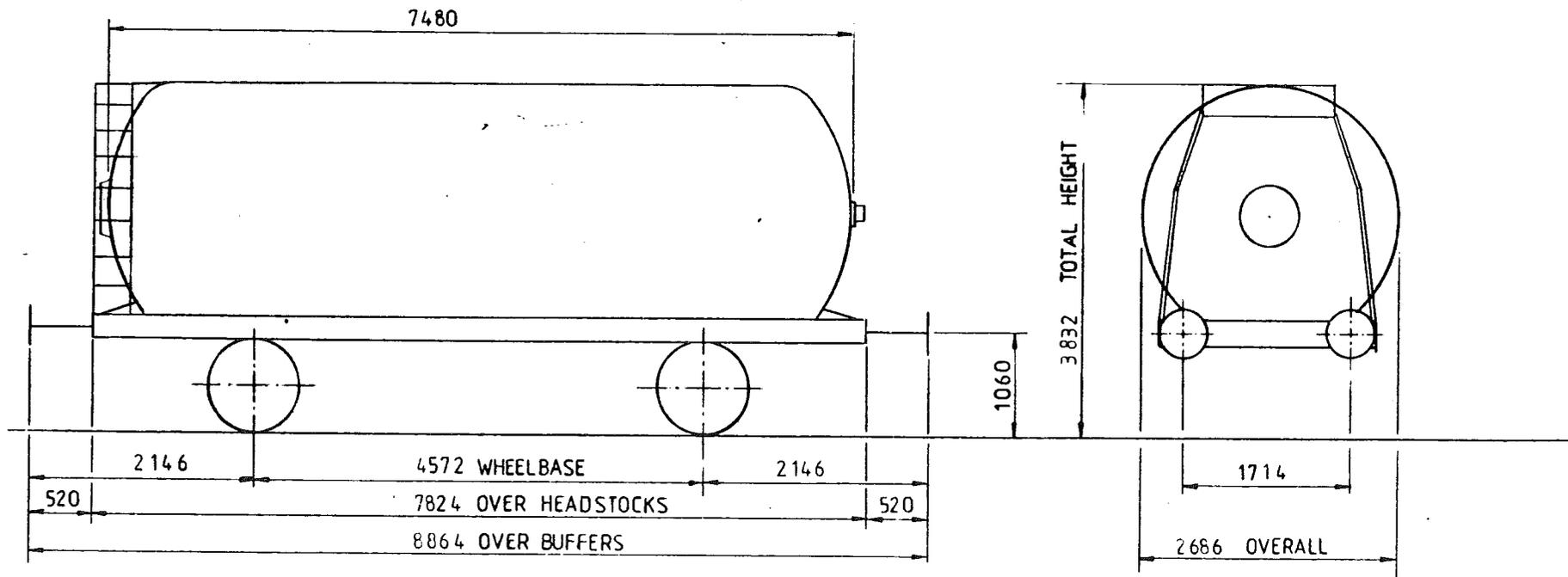

TARE	13 000	kg
CARRYING CAPACITY -	33 000	kg
CAPACITY -	38 605	Litres
MAX SPEED	60	mile/h
WHEELS	φ 952	
JOURNALS	φ 140	ROLLER BEARINGS

BUFFERS	HYDRAULIC	φ 406	HEADS
COUPLINGS	INSTANTER		
MIN CURVE	31m		
GEN ARRGT DRG	No		
BRAKE	AIR BLOCK,	HAND LEVER	
SUSPENSION	UIC DOUBLE LINK, PARABOLIC SPRINGS		

ISSUE 1

EX PO. DIAGRAM 6/172 (ALLOCATED)

46 tonne GLW TANK WAGON CLASS B

TT088M

EXCESS LENGTH 4	H	M	L	E
tonnes	46	46	13	13
VB				
AB	22	22	10	10
RA	8	8	1	1
MAX SPEED	60	60	60	60

TOPS CODE					
CARKND	AARKND	OPERATION			
T	T	A	T	A	A
		1	6	1	6

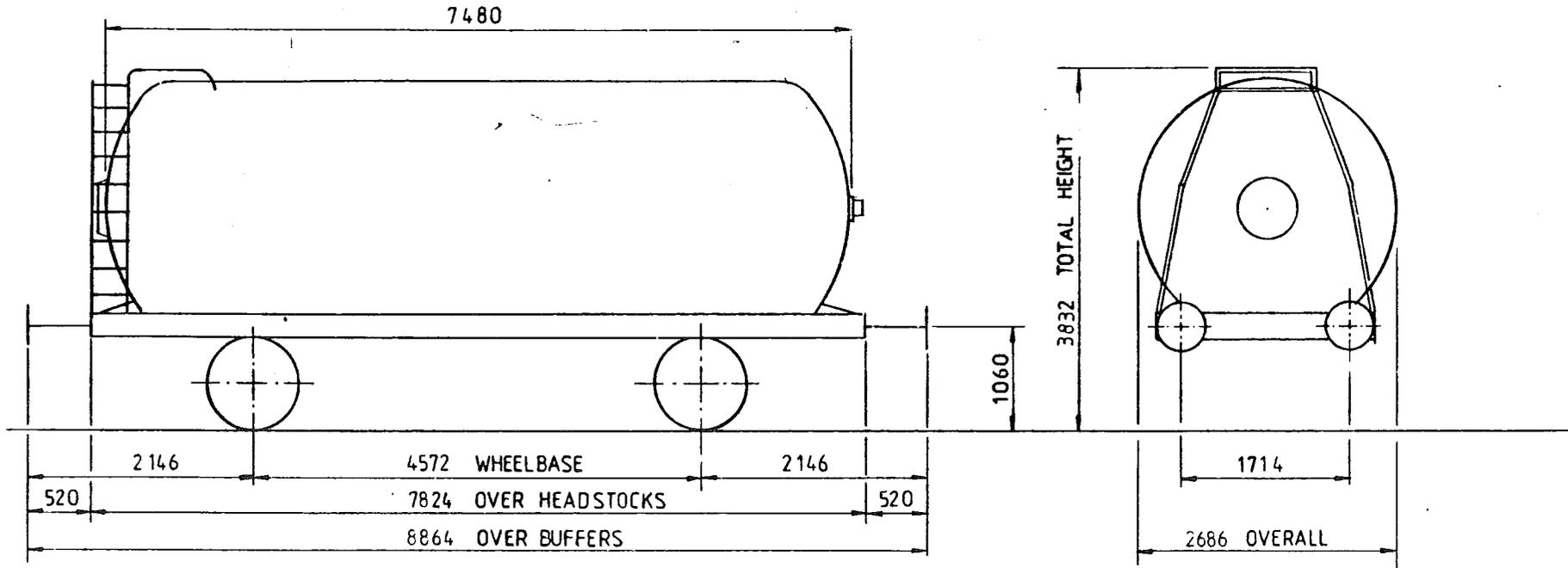

TARE	12550	kg
CARRYING CAPACITY -	33450	kg
CAPACITY -	39414	Litres
MAX SPEED	60	mile/h
WHEELS	φ 952	
JOURNALS	φ 140	ROLLER BEARINGS

BUFFERS	HYDRAULIC	φ 406	HEADS
COUPLINGS	INSTANTER		
MIN CURVE	31m		
GEN ARRG T DRG No			
BRAKE	AIR BLOCK,	HAND LEVER	
SUSPENSION	UIC DOUBLE LINK, PARAEOLIC SPRINGS		

ISSUE 1

EX PO. DIAGRAM 6/724 (ALLOCATED)

46 tonne GLW TANK WAGON CLASS B

TT088N

EXCESS LENGTH	4	H	M	L	E
tonnes	46	46	13	13	
VB					
AB	22	22	10	10	
RA	8	8	1	1	
MAX SPEED	60	60	60	60	

TOPS CODE					
CARKND	AARKND	CLASS	TYPE	WAGON	WAGON
T	T	A	T	A	A
1	6	1	6	1	6

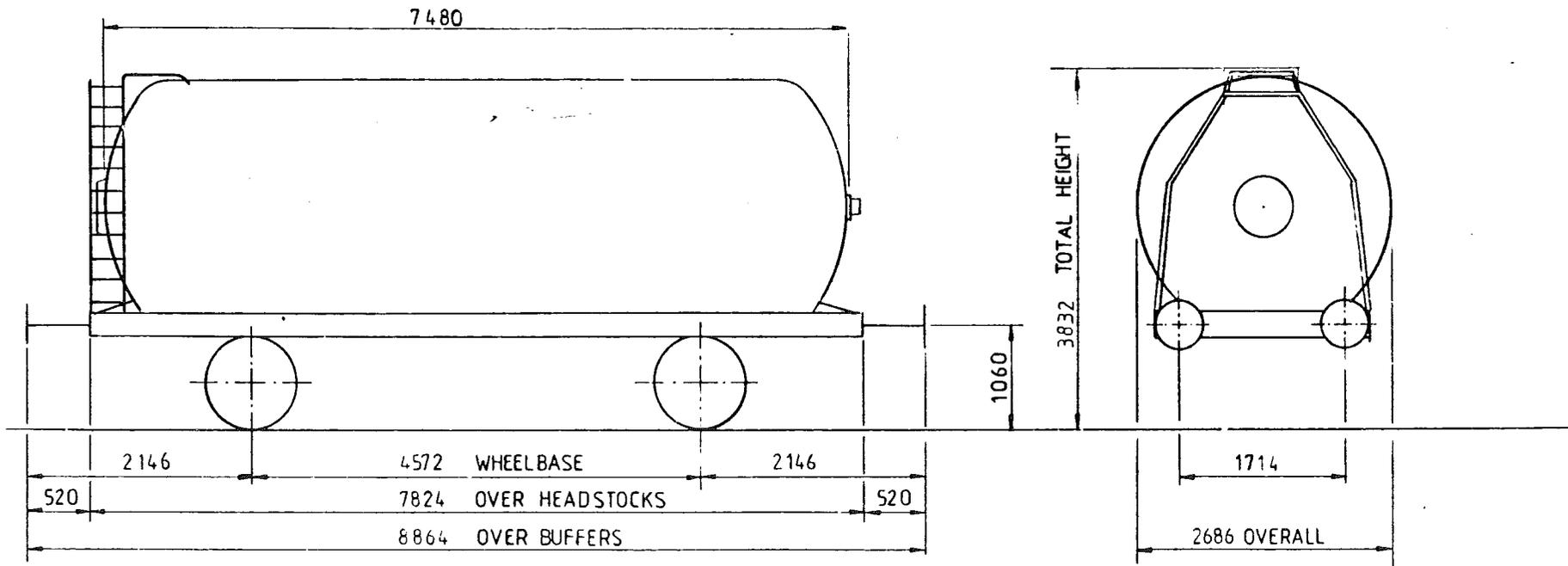

TARE	13050 kg
CARRYING CAPACITY -	32900 kg
CAPACITY -	38700 Litres
MAX SPEED	60 mile/h
WHEELS	Ø 952
JOURNALS	Ø 140 ROLLER BEARINGS

BUFFERS	HYDRAULIC Ø 406 HEADS
COUPLINGS	INSTANTER
MIN CURVE	31m
GEN ARRGT DRG No	
BRAKE	AIR BLOCK, HAND LEVER
SUSPENSION	FAT 26

ISSUE 1

EX PO. DIAGRAM 61725 (ALLOCATED)

46 tonnes GLW. TANK WAGON CLASS A

TT088P

EXCESS LENGTH	4	H	M	L	E
tonnes	46	46	13	13	
VB					
AB	22	22	10	10	
RA	8	8	1	1	
MAX SPEED	60	60	60	60	

TOPS CODE		
CARKND	AARKND	
T	T	A A 1 6 2 0

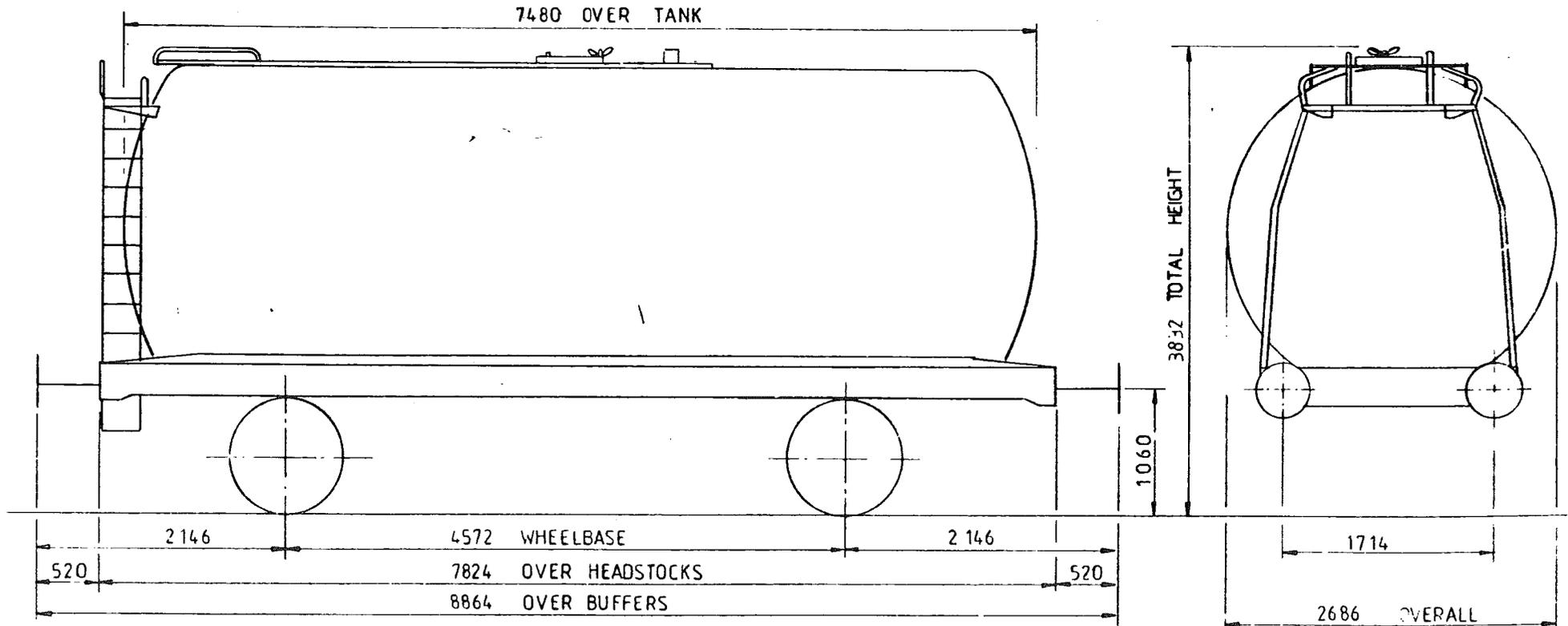

TARE	13000 kg
CARRYING CAPACITY -	33000 kg
CAPACITY -	38745 Litres
MAX SPEED	60 mile/h
WHEELS	φ 952
JOURNALS	φ140 ROLLER BEARINGS

BUFFERS	HYDRAULIC φ406 HEADS
COUPLINGS	INSTANTER
MIN CURVE	31 m
GEN ARRGT DRG No	
BRAKE	AIR BLOCK HAND LEVER
SUSPENSION	FAT 26

ISSUE 1

46 tonnes G.L.W. TANK WAGON OIL

TTO88Q

EXCESS LENGTH	4	H	M	L	E
tonnes	46	46	13	13	
AB	22	22	10	10	
NA	8	8	1	1	
MAX SPEED	60	60	60	60	

TOPS CODE			
CARKND	AARKND	CLASS	WAGON
T	T	A	A
6	2	0	

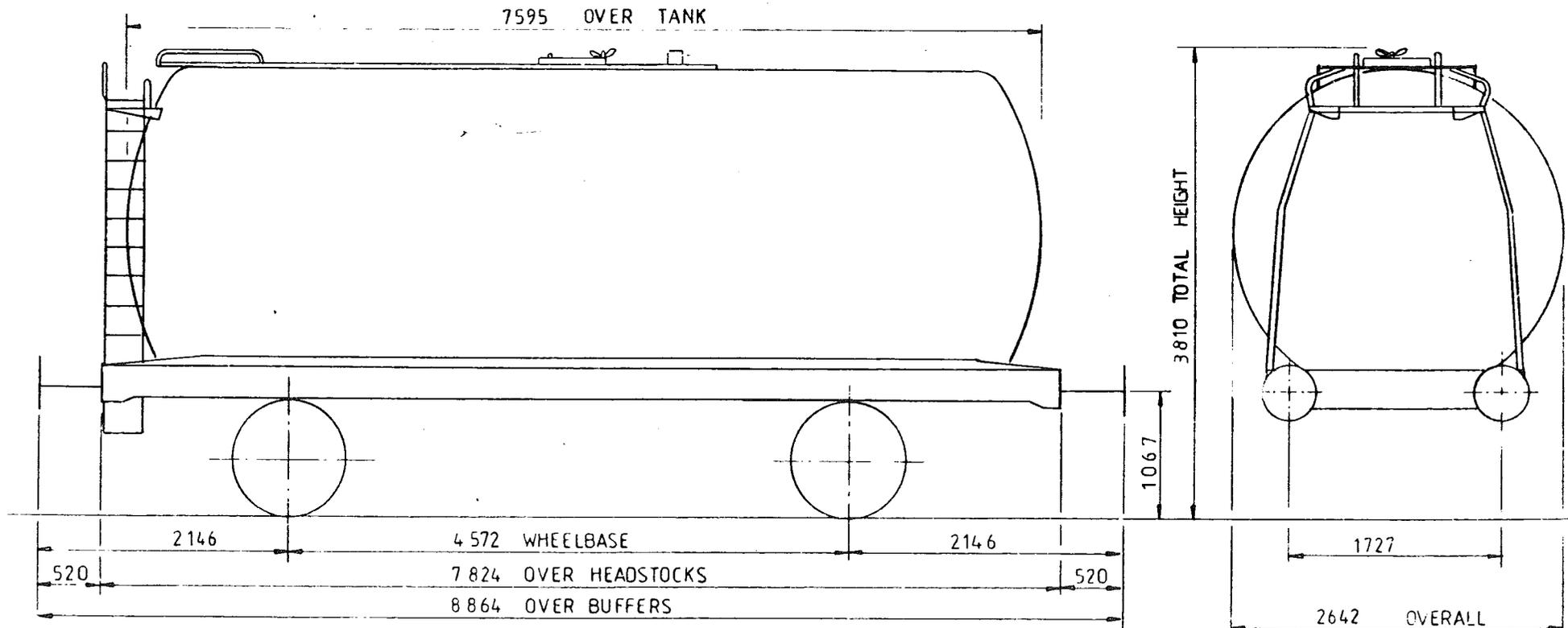

TARE	12 ¹⁰⁰ kg
CARRYING CAPACITY	33 ¹⁰⁰ kg
CAPACITY	39323 Litres
MAX SPEED	60 mile/h
WHEELS	φ 952
JOURNALS	φ140 ROLLER BEARINGS

BUFFERS	HYDRAULIC φ406 HEADS
COUPLINGS	INSTANTER
MIN CURVE	31 m
GEN ARRGT DRG NO	
BRAKE	AIR BLOCK HAND LEVER
SUSPENSION	FAT 26

ISSUE 1

46 tonnes G.L.W. TANK WAGON ACRYLONITRILE

TT 088R

EXCESS LENGTH	4	H	M	L	E
tonnes	46	46	13	13	
VB					
AB	22	22	10	10	
RA	8	8	1	1	
MAX SPEED	60	60	60	60	

TOPS CODE					
CARKND	AARKND	GENR'D PARTS			
T	T	A	T	A	A
				1	6 2 5

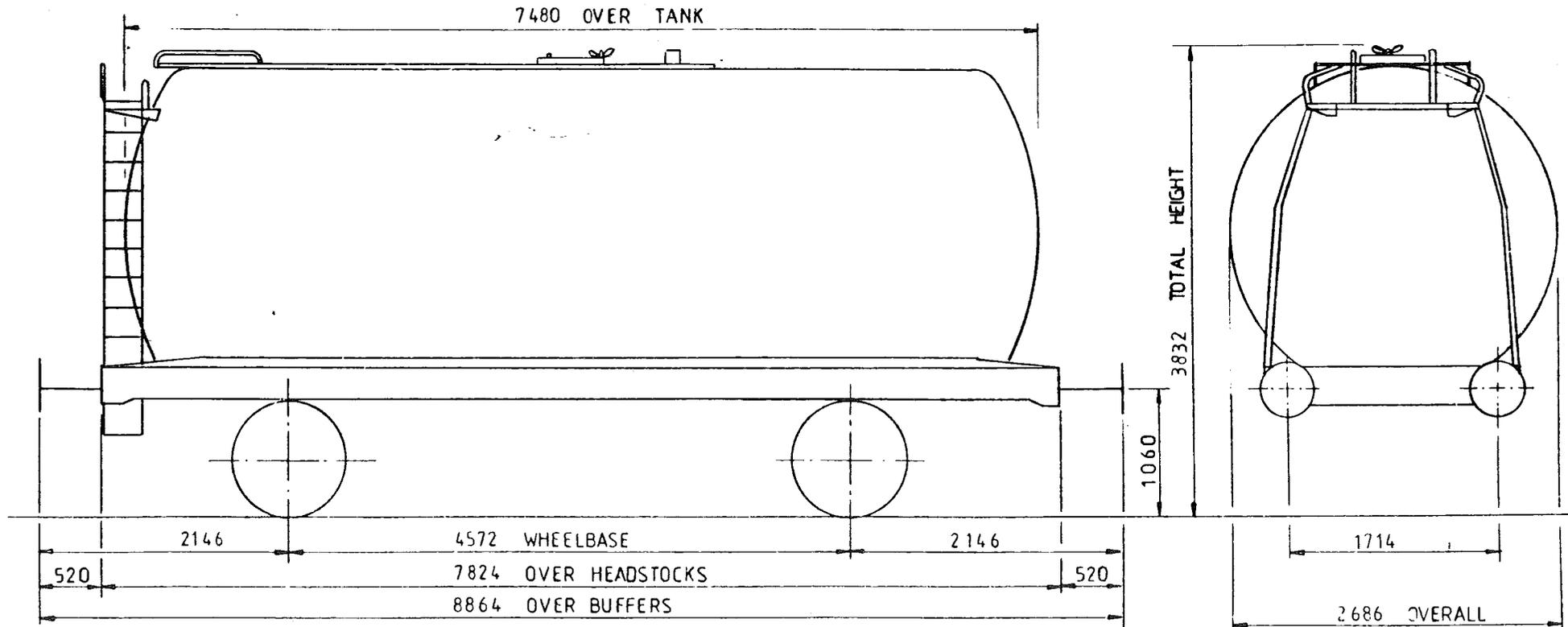

TARE	13 000 kg
CARRYING CAPACITY	33 000 kg
CAPACITY	38 359 Litres
MAX SPEED	60 mile/h
WHEELS	φ 952
JOURNALS	φ140 ROLLER BEARINGS

BUFFERS	HYDRAULIC φ406 HEADS
COUPLINGS	INSTANTER
MIN CURVE	31 m
GEN ARRGT DRG No	
BRAKE	AIR BLOCK HAND LEVER
SUSPENSION	FAT 26

ISSUE 1

EX PO DIAGRAM 6/714 (ALLOATED)

46tonne GLW TANK WAGON-CLASS 'A'

LOT NUMBER	

TOPS INFORMATION								
AARKND	OPERATING	OPERATING SPEED		BRAKE FORCE DATA		EXCESS LENGTH	RA (GLW)	DESIGN SHEET
CARKND	PANEL No.	60 mile/h UP TO	46 tonne GLW	10t FORCE UP TO	31tonne GLW	4	8	W973
T T A A	A	mile/h ABOVE		22t FORCE ABOVE				

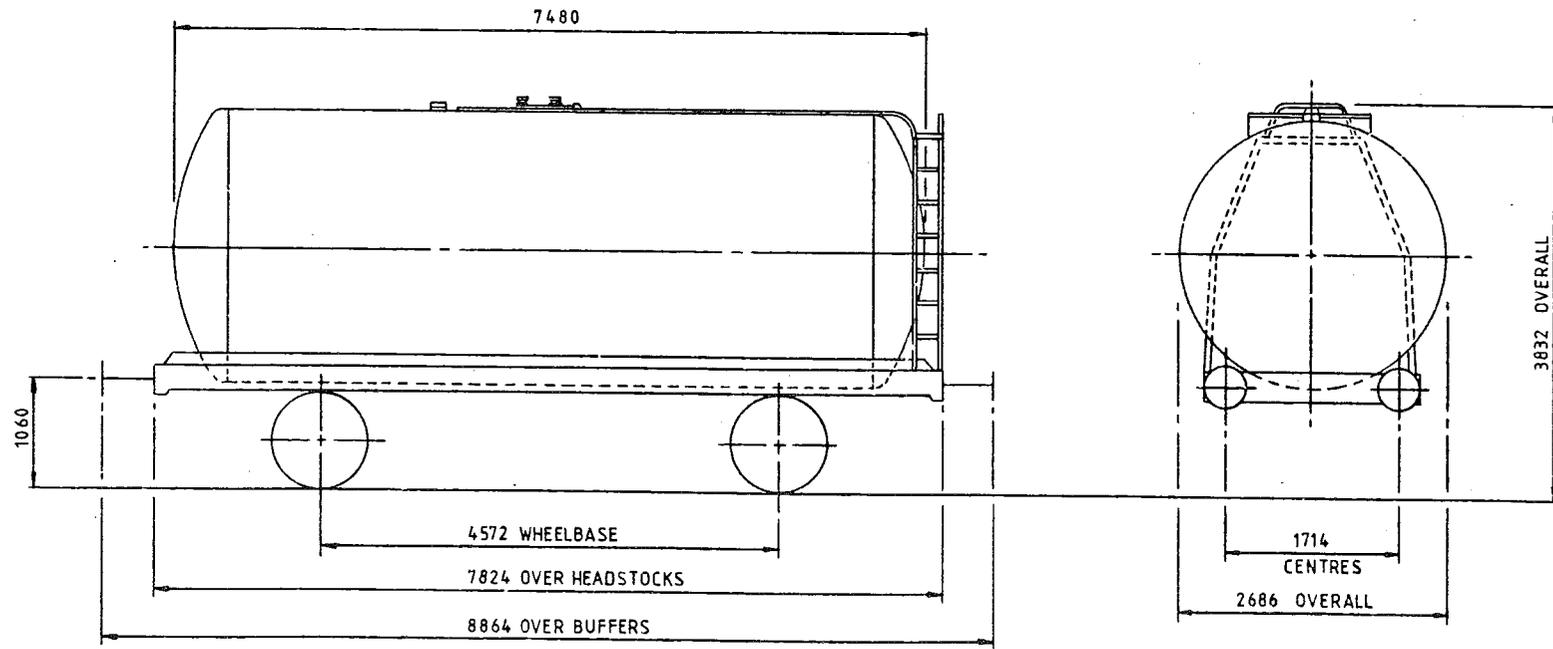

TARE-	13.000 Kg
CAPACITY, WEIGHT-	33000 Kg
CAPACITY, VOLUME-	38,359 litres
MIN. CURVE-	31m
GEN. ARRGT. DRG. NO.-	

BRAKE-	AIR BLOCK & HAND LEVER
SUSPENSION-	DOUBLE LINK & PARABOLIC SPRING
COUPLINGS-	INSTANTER
BUFFERS-	HYDRAULIC 406 DIA. HEADS
WHEELS-	952 DIA.
JOURNALS-	140 DIA. ROLLER BEARINGS

ISSUE 1

46 tonne GLW TANK WAGON-CLASS 'A'

LOT NUMBER	

TOPS INFORMATION						
AARKND	OPERATING	OPERATING SPEED		BRAKE FORCE DATA		EXCESS LENGTH
CARKND	PANEL No.	45 mile/h UP TO 13.15 tonne GLW		7t FORCE UP TO 24.5tonne GLW		RA (GLW)
T	A	A	A	60 mile/h ABOVE	21 t FORCE ABOVE	4
						8
						W1033

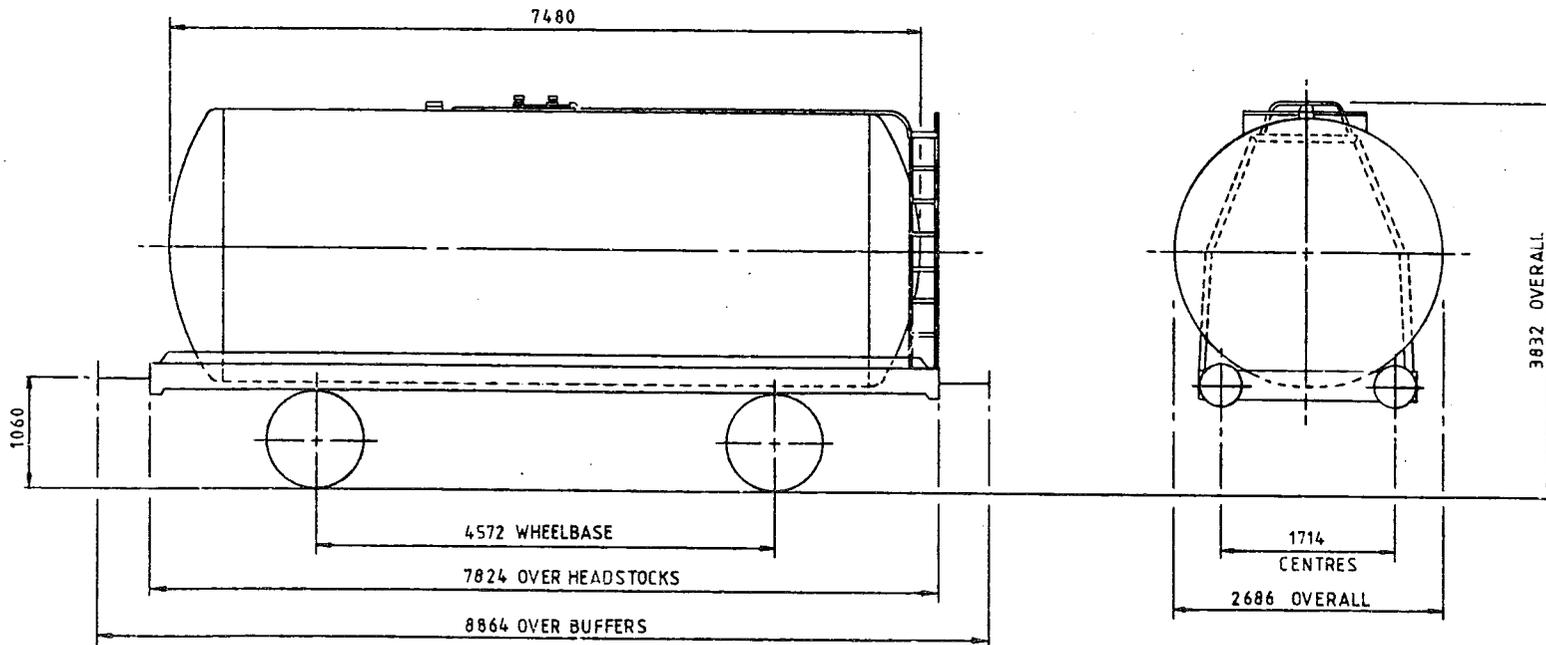

TARE-	13,150 Kg
CAPACITY, WEIGHT-	32,800 Kg
CAPACITY, VOLUME-PETROL	38,54 t; KERO-GAS OIL 38,745 t
MIN. CURVE-	31m
GEN. ARRGT. DRG. NO.-	

BRAKE-	AIR BLOCK & HAND LEVER
SUSPENSION-	DOUBLE LINK
COUPLINGS-	INSTANTER
BUFFERS-	HYDRAULIC 406 DIA. HEADS
WHEELS-	952 DIA.
JOURNALS-	140 DIA. ROLLER BEARINGS

ISSUE 1

46 tonne GLW TANK WAGON

LOT NUMBER	

TOPS INFORMATION								
AARKND	OPERATING	OPERATING SPEED		BRAKE FORCE DATA		EXCESS LENGTH	RA (GLW)	DESIGN SHEET
CARKND	PANEL No.	45 mile/h UP TO	12.9 tonne GLW	10t FORCE UP TO	30 tonne GLW	4	8	W1034
T T A A		60 mile/h ABOVE		22t FORCE ABOVE				

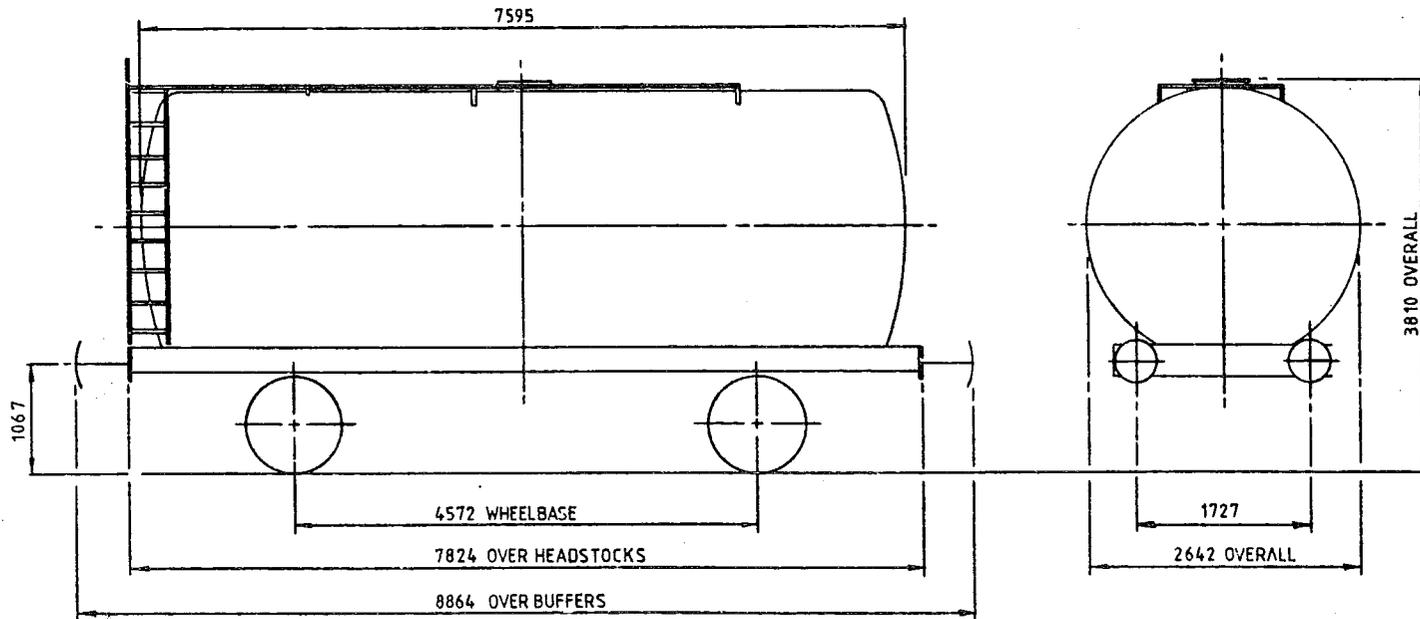

TARE-	12.900 Kg
CAPACITY, WEIGHT-	33.100 Kg
CAPACITY, VOLUME-	39.232 litres
MIN. CURVE-	31m
GEN. ARRGT. DRG. NO.-	

BRAKE-	AIR BLOCK & HAND LEVER
SUSPENSION-	DOUBLE LINK
COUPLINGS-	INSTANTER
BUFFERS-	HYDRAULIC 406 DIA.HEADS
WHEELS-	952 DIA.
JOURNALS-	140 DIA.ROLLER BEARINGS

ISSUE 1

46 tonne GLW TANK WAGON-CLASS 'A'

LOT NUMBER	

TOPS INFORMATION						
AARKND	OPERATING	OPERATING SPEED		BRAKE FORCE DATA		EXCESS
CARKND	PANEL No.	60 mile/h UP TO	46 tonne GLW	5t FORCE UP TO	30tonne GLW	LENGTH
T T A A		mile/h ABOVE		23t FORCE ABOVE		4
						RA (GLW)
						8
						DESIGN SHEET
						W1025

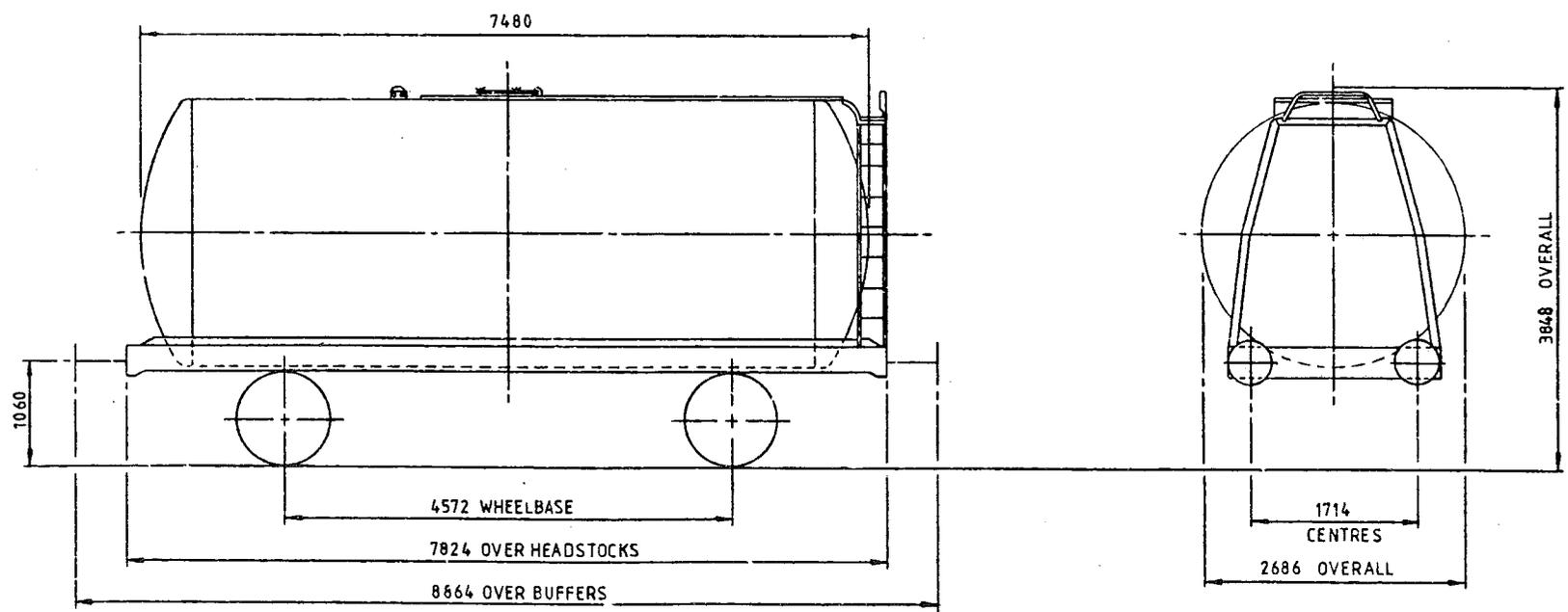

TARE-	13.200 Kg
CAPACITY, WEIGHT-	32.800 Kg
CAPACITY, VOLUME-	39 ⁴³⁶ litres
MIN. CURVE-	31m
GEN. ARRGT. DRG. NO.-	

BRAKE-	AIR BLOCK & HAND LEVER
SUSPENSION-	DOUBLE LINK & PARABOLIC SPRING
COUPLINGS-	INSTANTER
BUFFERS-	HYDRAULIC 406 DIA. HEADS
WHEELS-	952 DIA.
JOURNALS-	140 DIA. ROLLER BEARINGS.

ISSUE 1

46 tonne GLW TANK WAGON-CLASS 'A'

LOT NUMBER	

TOPS INFORMATION						
AARKND	OPERATING	OPERATING SPEED		BRAKE FORCE DATA		EXCESS LENGTH
CARKND	PANEL No.	60 mile/h UP TO	46 tonne GLW	5t FORCE UP TO	30 tonne GLW	RA (GLW)
T T A A		mile/h ABOVE		23t FORCE ABOVE		DESIGN SHEET
						W1026

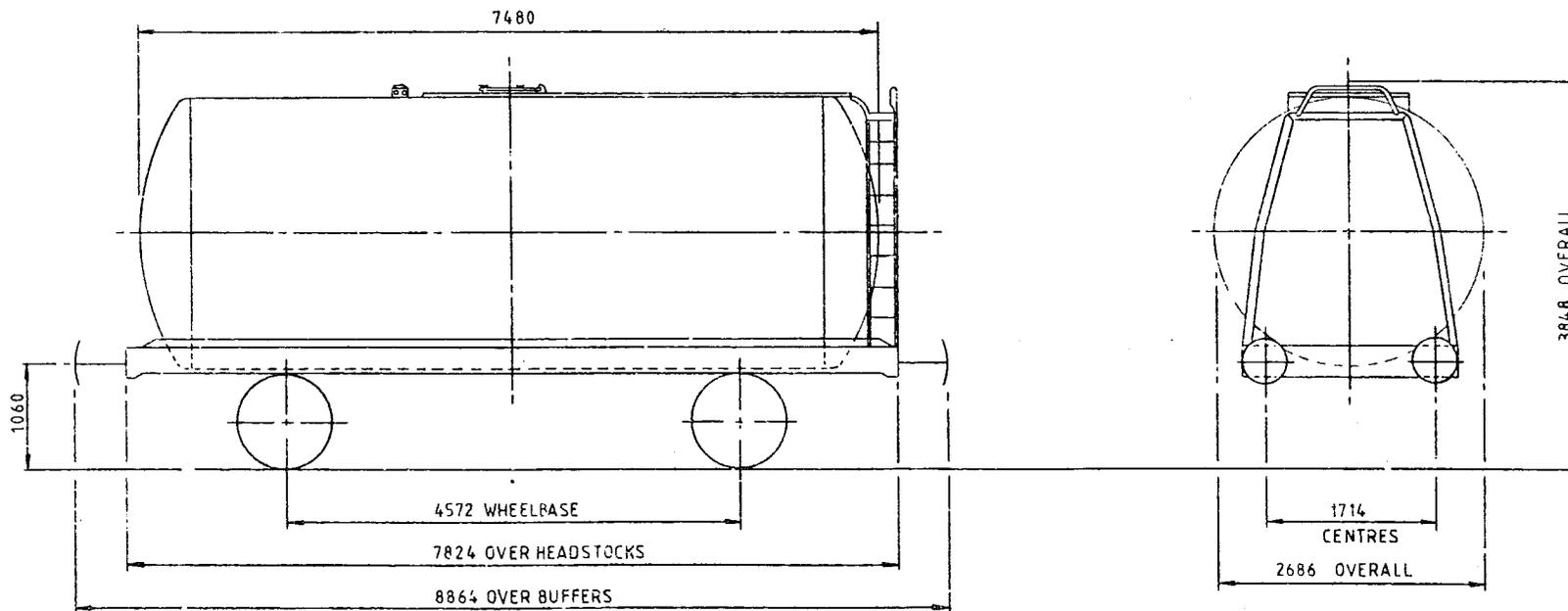

TARE-	13.200 Kg
CAPACITY, WEIGHT-	32.800 Kg
CAPACITY, VOLUME-	37.854, PETRO, 38.440, KERO-GAS OIL
MIN. CURVE-	31m
GEN. ARRGT. DRG. NO.-	

BRAKE-	AIR BLOCK & HAND LEVER
SUSPENSION-	DOUBLE LINK & PARABOLIC SPRING
COUPLINGS-	INSTANTER
BUFFERS-	HYDRAULIC 406 DIA. HEADS
WHEELS-	952 DIA.
JOURNALS-	140 DIA. ROLLER BEARINGS

ISSUE 1

46 tonne GLW TANK WAGON-CLASS 'A'

LOT NUMBER	

TOPS INFORMATION								
AARKND	OPERATING	OPERATING SPEED		BRAKE FORCE DATA		EXCESS LENGTH	RA (GLW)	DESIGN SHEET
CARKND	PANEL No.	60 mile/h UP TO	46 tonne GLW	10t FORCE UP TO	31tonne GLW			
T	T	A	A	mile/h ABOVE	mile/h ABOVE	4	9	W1062

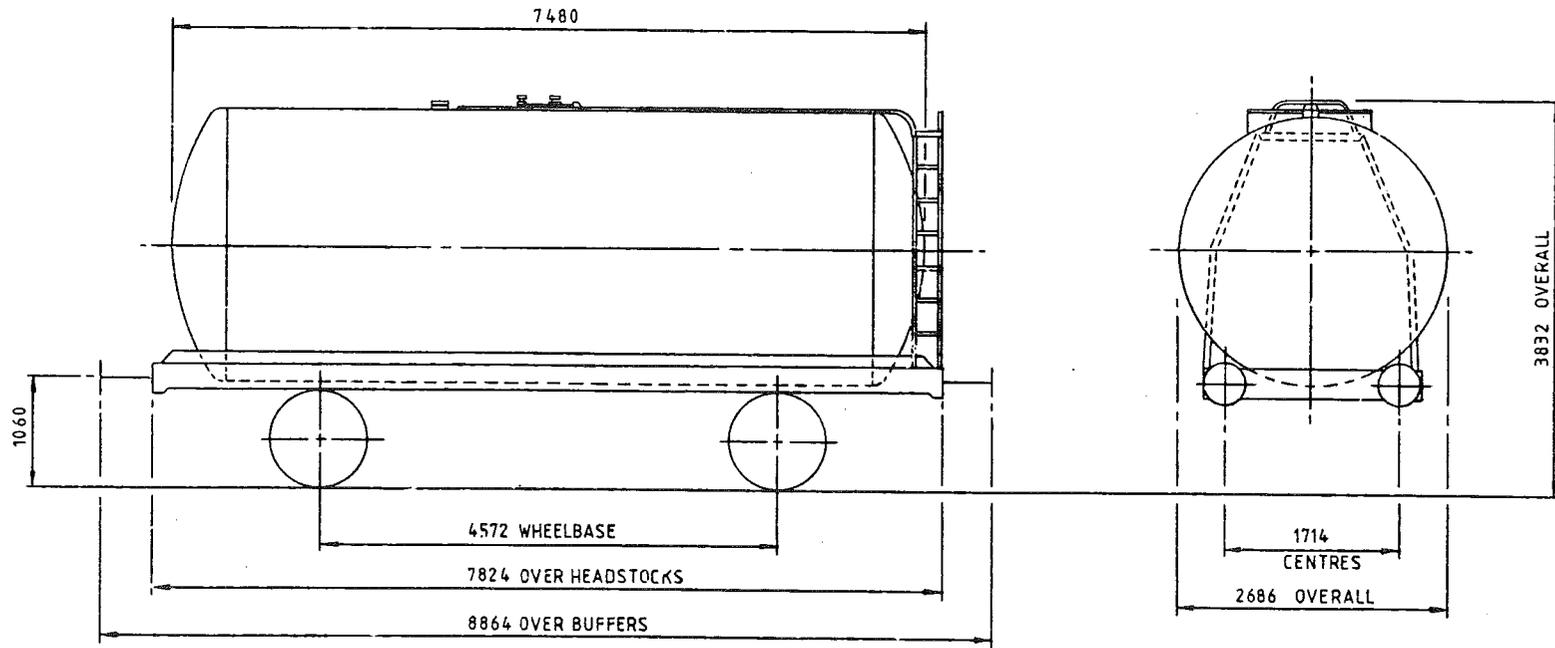

TARE-	12,800 Kg
CAPACITY, WEIGHT-	33,200 Kg
CAPACITY, VOLUME-PETROL	38,154 l
KERO-GAS OIL	38,745 l
MIN. CURVE-	31m
GEN. ARRGT. DRG. NO.-	

BRAKE-	AIR BLOCK & HAND LEVER
SUSPENSION-	DOUBLE LINK & PARABOLIC SPRING
COUPLINGS-	INSTANTER
BUFFERS-	HYDRAULIC 406 DIA. HEADS
WHEELS-	952 DIA.
JOURNALS-	140 DIA. ROLLER BEARINGS

ISSUE 1

46 tonne GLW TANK WAGON-CLASS 'A'

LOT NUMBER	

TOPS INFORMATION								
AARKND	OPERATING	OPERATING SPEED		BRAKE FORCE DATA		EXCESS	RA	DESIGN
CARKND	PANEL No.	60 mile/h UP TO		7t FORCE UP TO		LENGTH	(GLW)	SHEET
T T A A		mile/h ABOVE		24.5 tonne GLW		4	9	W1063

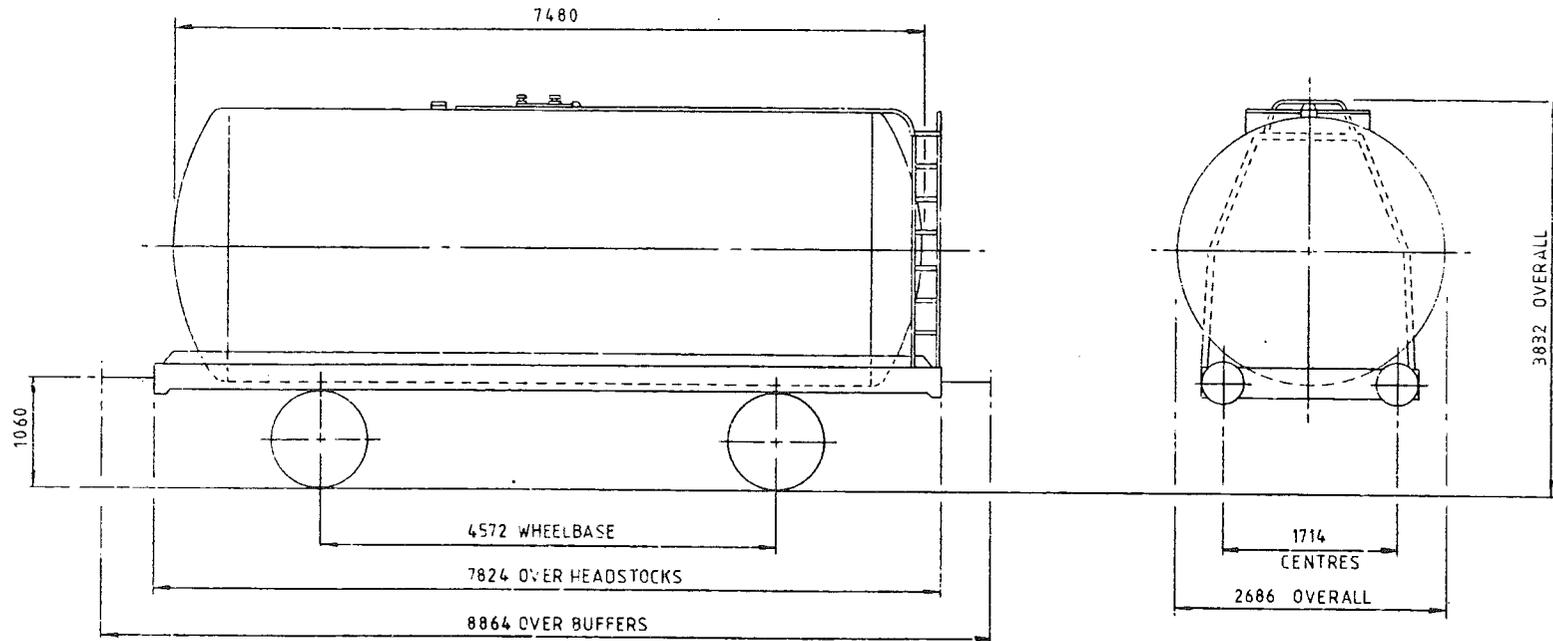

TARE-	12.750 Kg
CAPACITY, WEIGHT-	33250 Kg
CAPACITY, VOLUME-PETROL	38 ¹⁵⁴ l
KERO-GAS OIL	38 ⁷⁴⁵ l
MIN. CURVE-	31 m
GEN. ARRGT. DRG. NO.-	

BRAKE-	AIR BLOCK & HAND LEVER
SUSPENSION-	DOUBLE LINK & PARABOLIC SPRING
COUPLINGS-	INSTANTER
BUFFERS-	HYDRAULIC 406 DIA. HEADS
WHEELS-	952 DIA.
JOURNALS-	140 DIA. ROLLER BEARINGS

ISSUE 1

46 TONNE GLW TANK WAGON

TT 089A

EXCESS LENGTH	H	M	L	E
tonnes	46	46	13	13
VB				
AB	29	29	8	8
RA	8	8	1	1
MAX SPEED	60	60	60	60

TOPS CODE		
CARKND	AARKND	OPERATING PANEL No
T T A	T T A A	1 6 2 2

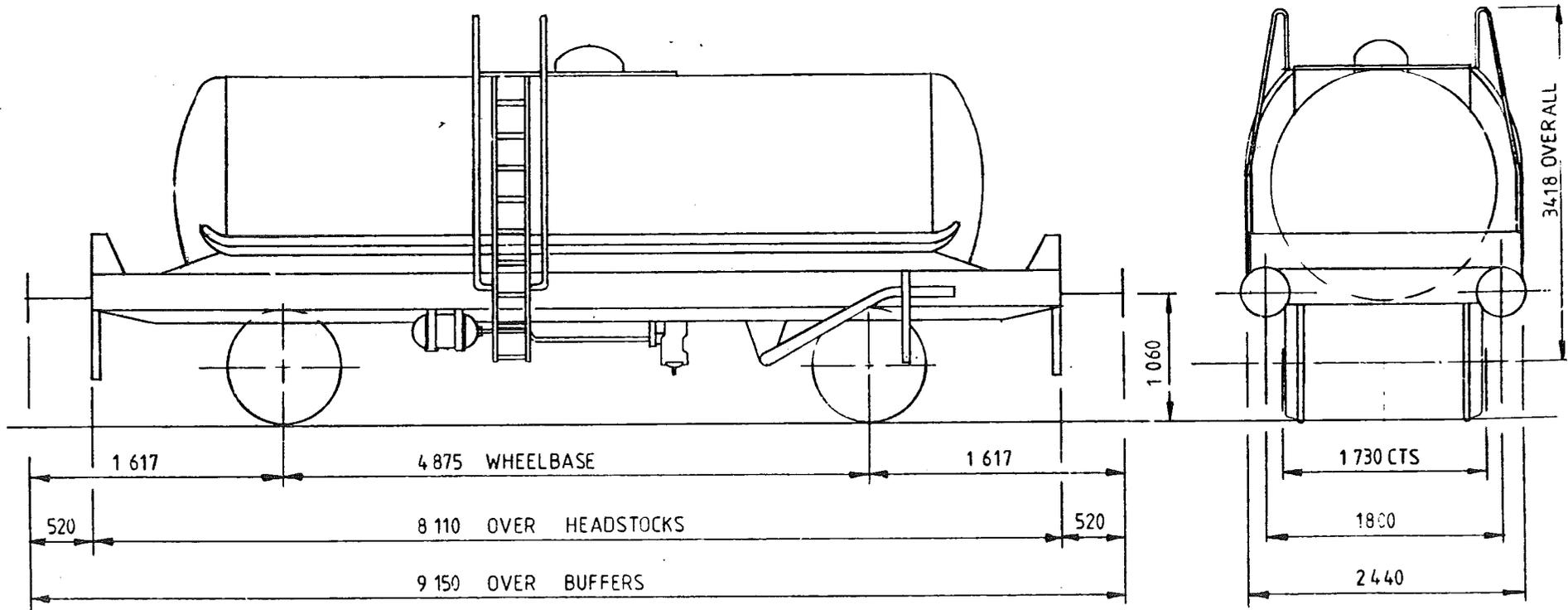

TARE -	12 ⁵⁰⁰ Kg
CARRYING CAPACITY -	33 ⁵⁰⁰ Kg
CAPACITY -	15 ⁸⁵⁰ Kg
MAX. SPEED -	60 mph
WHEELS -	953 DIA
JOURNALS -	150 DIA ROLLER BEARINGS

BUFFERS	HYDRAULIC, 406 DIA HEADS
COUPLINGS	INSTANTER
MIN. CURVE	50m
GEN ARRGT. DRG No.	-
BRAKE	AIR BLOCK & HAND LEVER
SUSPENSION	GLOUCESTER PEDESTAL

ISSUE 1

46 tonne GLW TANK WAGON

LOT NUMBER	

TOPS INFORMATION										
AARKND		OPERATING		OPERATING SPEED		BRAKE FORCE DATA		EXCESS LENGTH	RA (GLW)	DESIGN SHEET
CARKND		PANEL No.		60 mile/h UP TO mile/h ABOVE		46 tonne GLW		0.24 + (0.48 x tonnes)		
T	T	B	A					6	8	

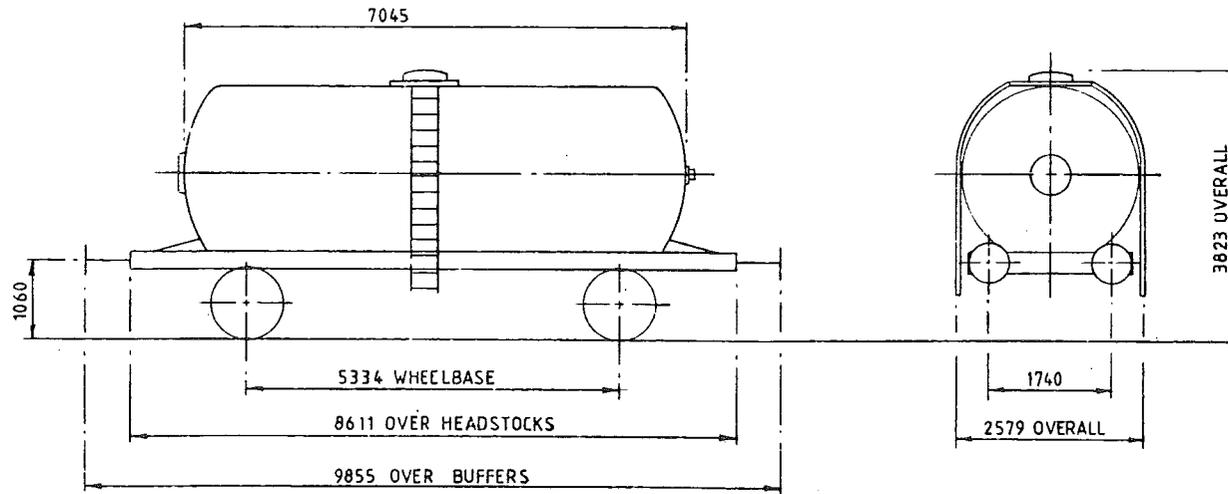

TARE-	18,200 Kg
CAPACITY, WEIGHT-	27,800 Kg
CAPACITY, VOLUME-	23,700 litres
MIN. CURVE-	31m
GEN. ARRGT. DRG. NO.-	682910/01 C.ROBERTS

BRAKE-	AIR BLOCK, THRO. VAC. PIPE, HAND LEVER
SUSPENSION-	13 LEAF SPRING, RUBBER SECONDARY SUSPENSION
COUPLINGS-	INSTANTER
BUFFERS-	HYDRAULIC 406 DIA HEADS
WHEELS-	952 DIA
JOURNALS-	140 DIA ROLLER BEARINGS

ISSUE 1

46 tonne GLW TANK WAGON

TT090B

EXCESS LENGTH	4	H	M	L	E
tonnes	46	46	18	18	
VB					
AB	25	25	11	11	
RA	8	8	1	1	
MAX SPEED	60	60	60	60	

TOPS CODE		
CARKND	AARKND	ERRAND
T	T	A
L	1	0
4	1	

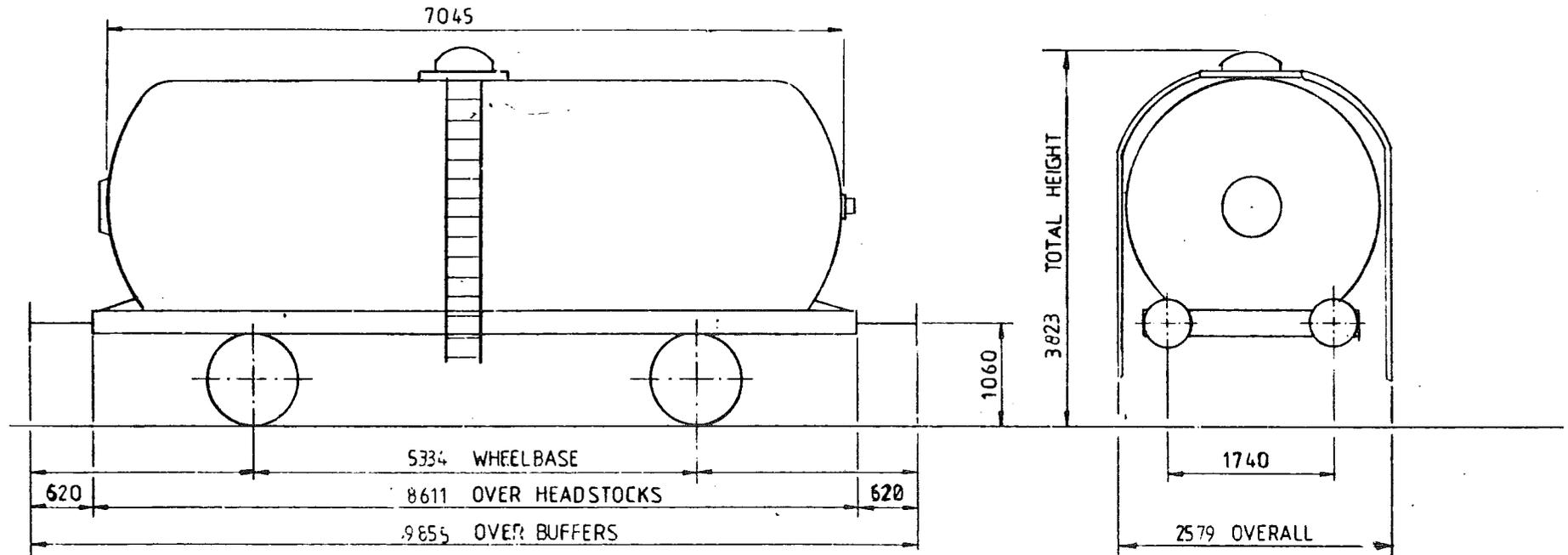

TARE	18 ⁰⁰⁰	kg
CARRYING CAPACITY -	27 ⁰⁰⁰	kg
CAPACITY -	23700	Litres
MAX SPEED	60	mile/h
WHEELS	φ 952	
JOURNALS	φ 140	ROLLER BEARINGS

BUFFERS	HYDRAULIC	φ 406	HEADS
COUPLINGS	INSTANTER		
MIN CURVE	31m		
GEN ARRGT DRG No 682910 / 01 C ROBERTS			
BRAKE	AIR BLOCK,	HAND LEVER	
SUSPENSION 13 LEAF SPRING, RUBBER SECONDARY SUSPN			

ISSUE 1

EX DIAGRAM/37G (ALLOCATED)

46 tonne GLW TANK WAGON

LOT NUMBER	

TOPS INFORMATION										
AARKND	OPERATING			OPERATING SPEED		BRAKE FORCE DATA		EXCESS LENGTH	RA (GLW)	DESIGN SHEET
CARKND	PANEL No.			60 mile/h UP TO		46 tonne GLW		6	9	W1144
TTA				mile/h ABOVE		0.24+ (0.48 x tonnes)				

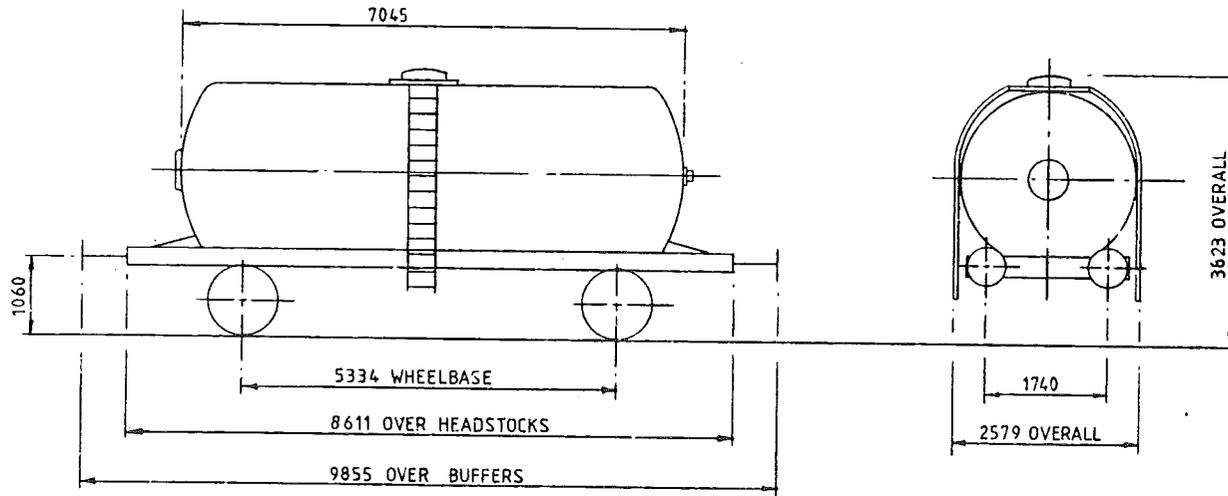

TARE-	18,550 Kg
CAPACITY, WEIGHT-	27,450 Kg
CAPACITY, VOLUME-	23,700 litres
MIN. CURVE-	31m
GEN. ARRGT. DRG. NO.-	682910/OI C.ROBERTS

BRAKE-	AIR BLOCK & HAND LEVER
SUSPENSION-	13 LEAF SPRING, RUBBER SECONDARY SUSPENSION
COUPLINGS-	INSTANTER
BUFFERS-	HYDRAULIC 406 DIA HEADS
WHEELS-	952 DIA
JOURNALS-	140 DIA ROLLER BEARINGS

ISSUE 1

46 tonne GLW TANK WAGON-CLASS 'B'

LOT NUMBER	

TOPS INFORMATION						
AARKND	OPERATING PANEL No.	OPERATING SPEED		BRAKE FORCE DATA		EXCESS LENGTH
CARKND		60 mile/h UP TO	46 tonne GLW	10t FORCE UP TO	3t tonne GLW	4
T T B A		mile/h ABOVE		22t FORCE ABOVE		
						RA (GLW)
						9
						DESIGN SHEET
						W1082

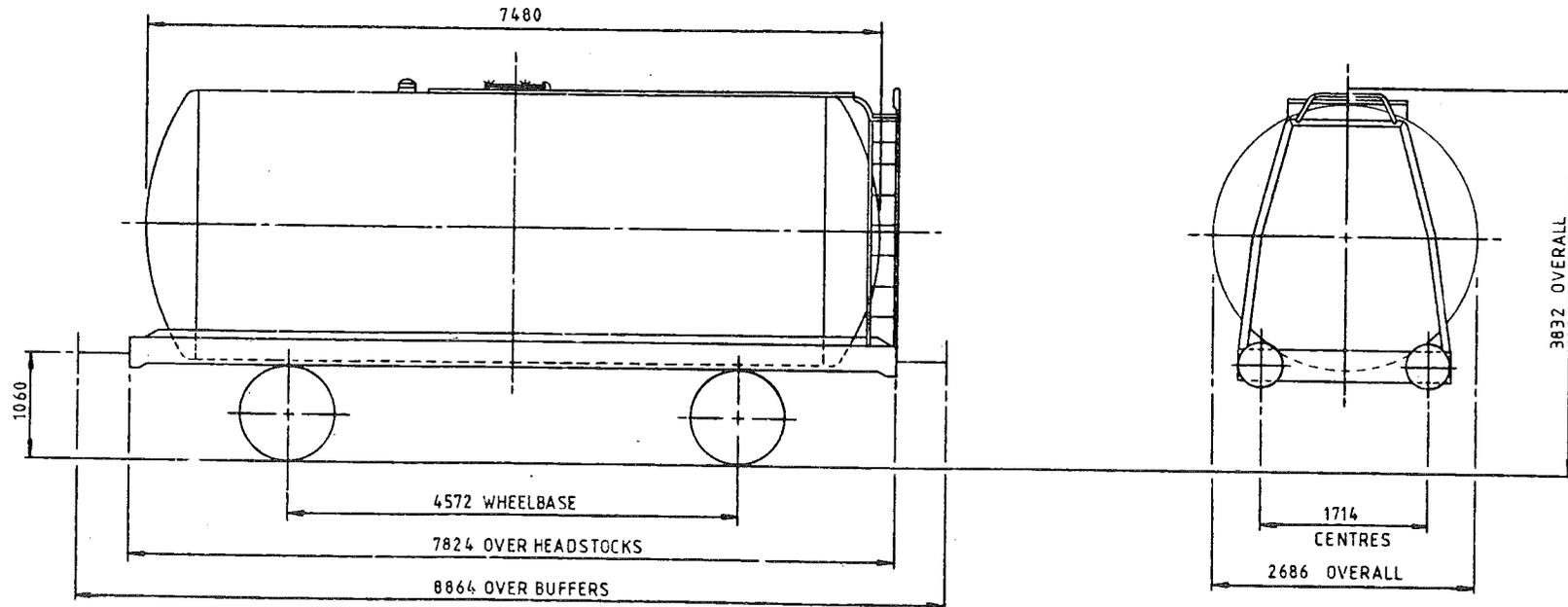

TARE-	12.750 Kg
CAPACITY, WEIGHT-	33,300 Kg
CAPACITY, VOLUME-	38,700 litres
MIN. CURVE-	31m.
GEN. ARRGT. DRG. NO.-	

BRAKE-	AIR BLOCK, VACUUM PIPED & HAND LEVER
SUSPENSION-	SINGLE LINK & PARABOLIC SPRING
COUPLINGS-	INSTANTER
BUFFERS-	HYDRAULIC 406 DIA. HEADS
WHEELS-	952 DIA.
JOURNALS-	140 DIA. ROLLER BEARINGS

ISSUE 1

46 tonne GLW TANK WAGON-CLASS 'A'

LOT NUMBER	

TOPS INFORMATION									
AARKND	OPERATING		OPERATING SPEED		BRAKE FORCE DATA		EXCESS LENGTH	RA (GLW)	DESIGN SHEET
CARKND	PANEL No.		45 mile/h UP TO	13.2 tonne GLW	5t FORCE UP TO	31 tonne GLW	4	9	W1106
T T A A			60 mile/h ABOVE		23t FORCE ABOVE				

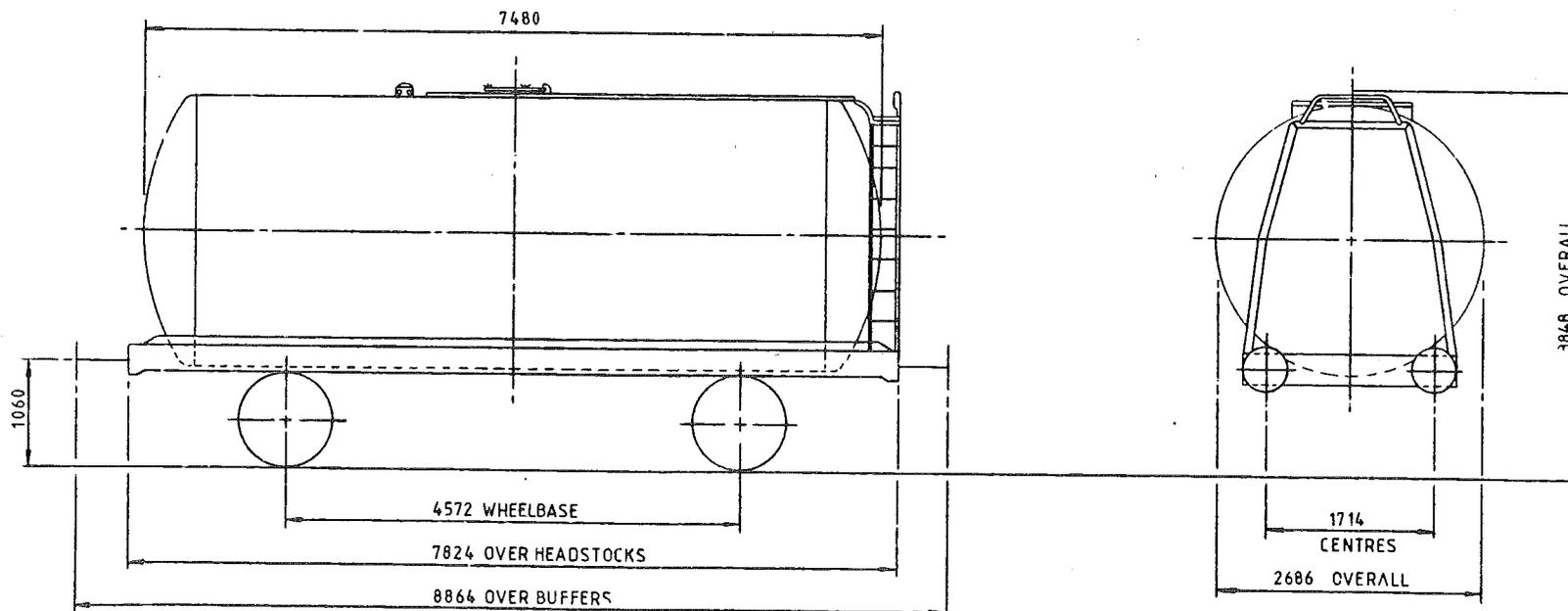

TARE-	13,200 Kg
CAPACITY, WEIGHT-	32,800 Kg
CAPACITY, VOLUME-	39,436 litres
MIN. CURVE-	31m
GEN. ARRGT. DRG. NO.-	

BRAKE-	AIR BLOCK & HAND LEVER
SUSPENSION-	DOUBLE LINK
COUPLINGS-	INSTANTER
BUFFERS-	HYDRAULIC 406 DIA. HEADS
WHEELS-	952 DIA.
JOURNALS-	140 DIA. ROLLER BEARINGS

ISSUE 1

46 tonne GLW TANK WAGON-CLASS 'A'

LOT NUMBER	

TOPS INFORMATION								
AARKND	OPERATING	OPERATING SPEED		BRAKE FORCE DATA		EXCESS LENGTH	RA (GLW)	DESIGN SHEET
CARKND	PANEL No.	45 mile/h UP TO	13.2 tonne GLW	5t FORCE UP TO	3t tonne GLW	4	9	W1104
T T A A		60 mile/h ABOVE		23t FORCE ABOVE				

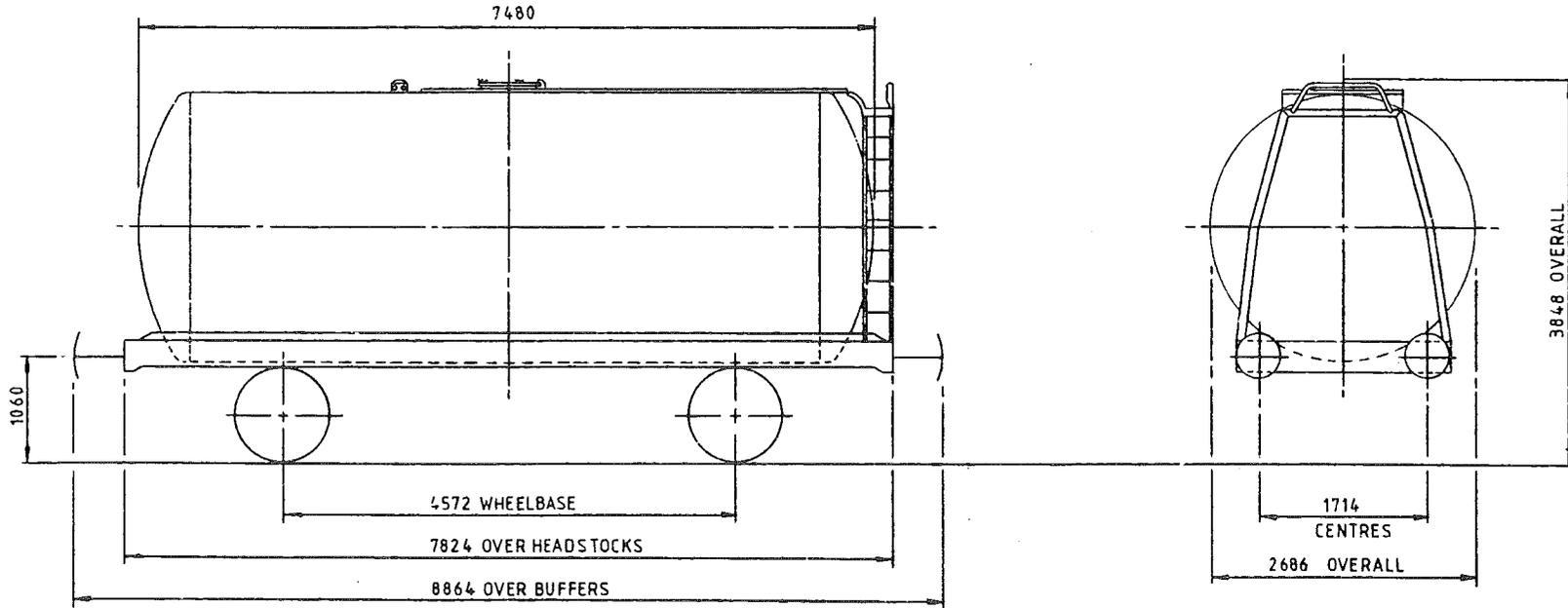

TARE-	13.200 Kg
CAPACITY, WEIGHT-	32.800 Kg
CAPACITY, VOLUME-	37,854l PETROL 38,440l KERO-GASOIL
MIN. CURVE-	31m
GEN. ARRGT. DRG. NO.-	

BRAKE-	AIR BLOCK & HAND LEVER
SUSPENSION-	DOUBLE LINK
COUPLINGS-	INSTANTER
BUFFERS-	HYDRAULIC 406 DIA. HEADS
WHEELS-	952 DIA.
JOURNALS-	140 DIA. ROLLER BEARINGS

ISSUE 1

46 tonne GLW TANK WAGON—CLASS 'A'

LOT NUMBER	

TOPS INFORMATION						
AARKND	OPERATING	OPERATING SPEED		BRAKE FORCE DATA		EXCESS LENGTH
CARKND	PANEL No.	45 mile/h UP TO 60 mile/h ABOVE		10t FORCE UP TO 22t FORCE ABOVE		RA (GLW)
T T A A		12.65 tonne GLW		30 tonne GLW		4
						9
						W1165

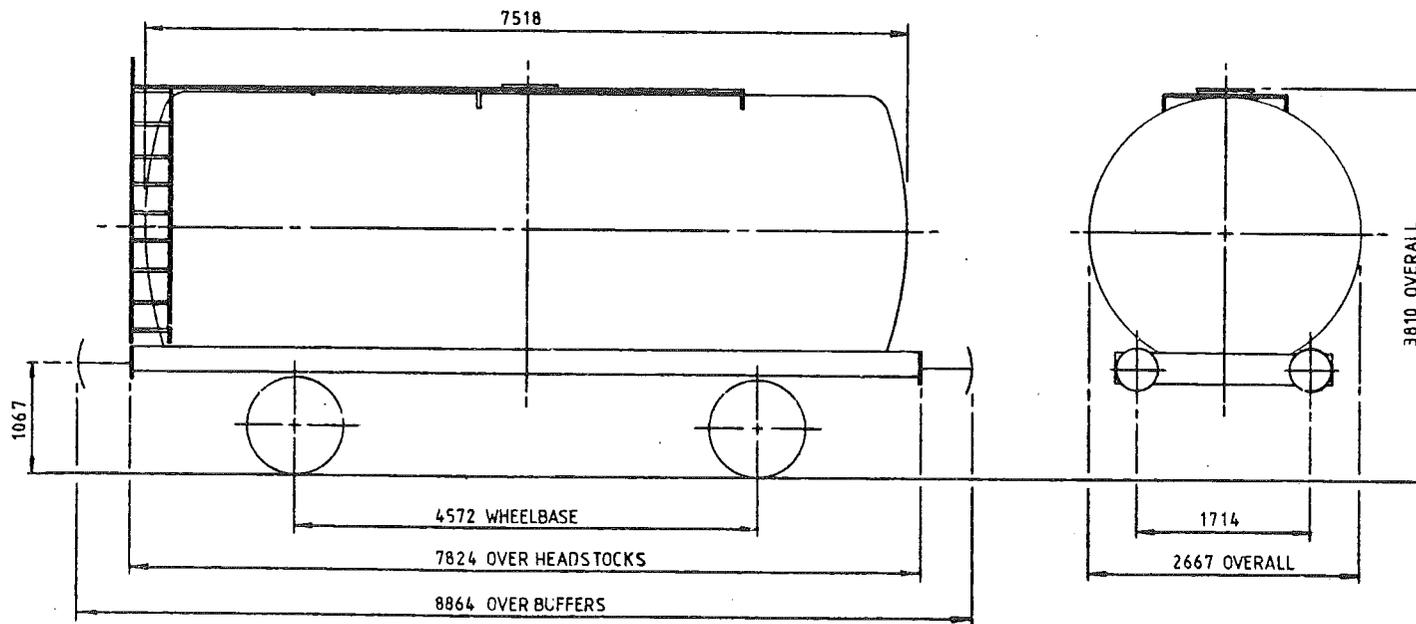

TARE-	12650 Kg
CAPACITY, WEIGHT-	33,350 Kg
CAPACITY, VOLUME-	40,000 litres
MIN. CURVE-	31m
GEN. ARRGT. DRG. NO.-	

BRAKE-	AIR BLOCK & HAND LEVER
SUSPENSION-	DOUBLE LINK
COUPLINGS-	INSTANTER
BUFFERS-	HYDRAULIC 406 DIA. HEADS
WHEELS-	952 DIA.
JOURNALS-	140 DIA. ROLLER BEARINGS

ISSUE 1

46 tonne GLW TANK WAGON—CLASS 'A'

LOT NUMBER	

TOPS INFORMATION										
AARKND	OPERATING			OPERATING SPEED		BRAKE FORCE DATA		EXCESS LENGTH	RA (GLW)	DESIGN SHEET
CARKND	PANEL No.			45 mile/h UP TO	12.7 tonne GLW	6t FORCE UP TO	28 tonne GLW	4	9	W1166
T T A A				60 mile/h ABOVE		25t FORCE ABOVE				

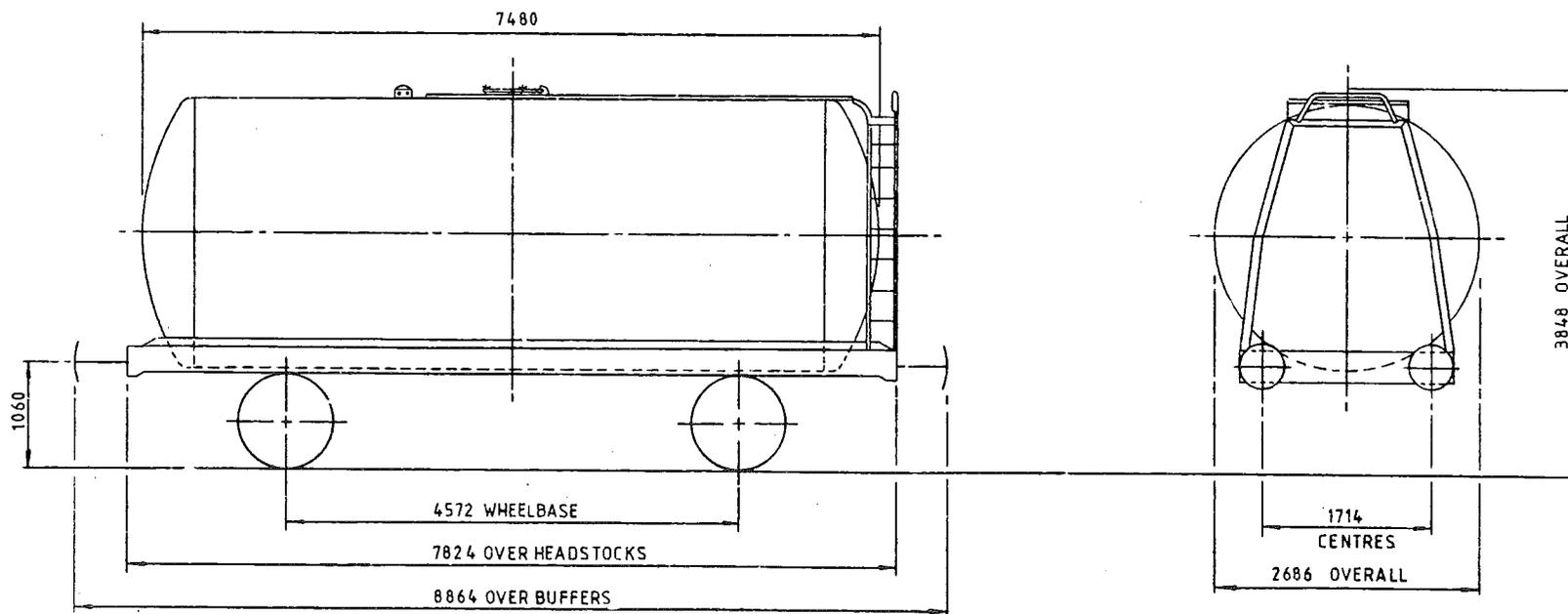

TARE-	12.700 Kg
CAPACITY, WEIGHT-	33,300 Kg
CAPACITY, VOLUME-	37.854 PETROL 38.440 KERO-GAS OIL
MIN. CURVE-	31m
GEN. ARRGT. DRG. NO.-	

BRAKE-	AIR BLOCK & HAND LEVER
SUSPENSION-	DOUBLE LINK
COUPLINGS-	INSTANTER
BUFFERS-	HYDRAULIC 406 DIA. HEADS
WHEELS-	952 DIA.
JOURNALS-	140 DIA. ROLLER BEARINGS

ISSUE 1

46tonne GLW TANK WAGON-CLASS 'A'

LOT NUMBER	

TOPS INFORMATION						
AARKND	OPERATING	OPERATING SPEED		BRAKE FORCE DATA		EXCESS LENGTH
CARKND	PANEL No.	60 mile/h UP TO	46 tonne GLW	10t FORCE UP TO	31tonne GLW	RA (GLW)
T T A A		mile/h ABOVE		22t FORCE ABOVE		DESIGN SHEET
						4 8 W1164

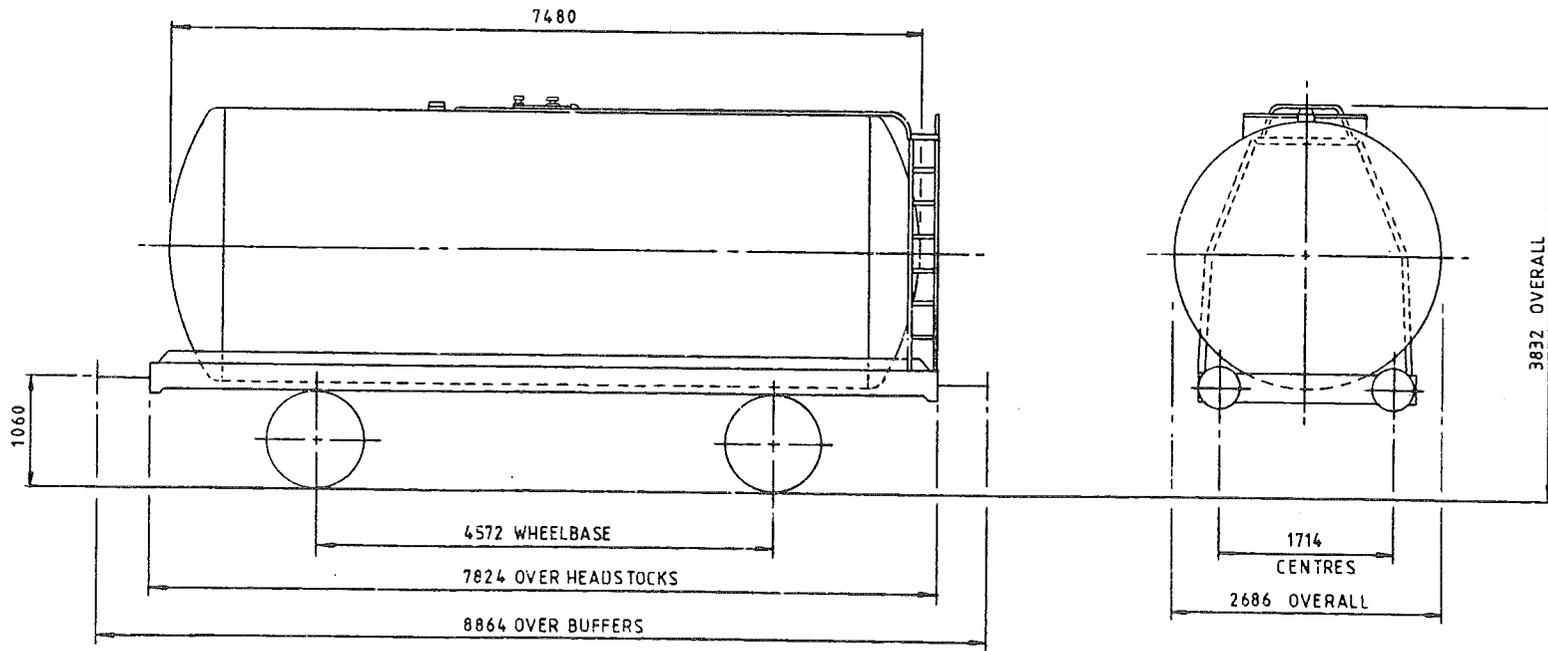

TARE-	12.650 Kg
CAPACITY, WEIGHT-	33350 Kg
CAPACITY, VOLUME-	39.414 litres
MIN. CURVE-	31m
GEN. ARRGT. DRG. NO.-	

BRAKE-	AIR BLOCK & HAND LEVER
SUSPENSION-	DOUBLE LINK & PARABOLIC SPRING
COUPLINGS-	INSTANTER
BUFFERS-	HYDRAULIC 406 DIA. HEADS
WHEELS-	952 DIA.
JOURNALS-	140 DIA. ROLLER BEARINGS

ISSUE 1

46 tonne GLW TANK WAGON-CLASS 'A'

LOT NUMBER	

TOPS INFORMATION								
AARKND	OPERATING	OPERATING SPEED		BRAKE FORCE DATA		EXCESS LENGTH	RA (GLW)	DESIGN SHEET
CARKND	PANEL No.	60 mile/h UP TO mile/h ABOVE 46 tonne GLW		10t FORCE UP TO	31tonne GLW			
T	T	A	A			4	8	W1167

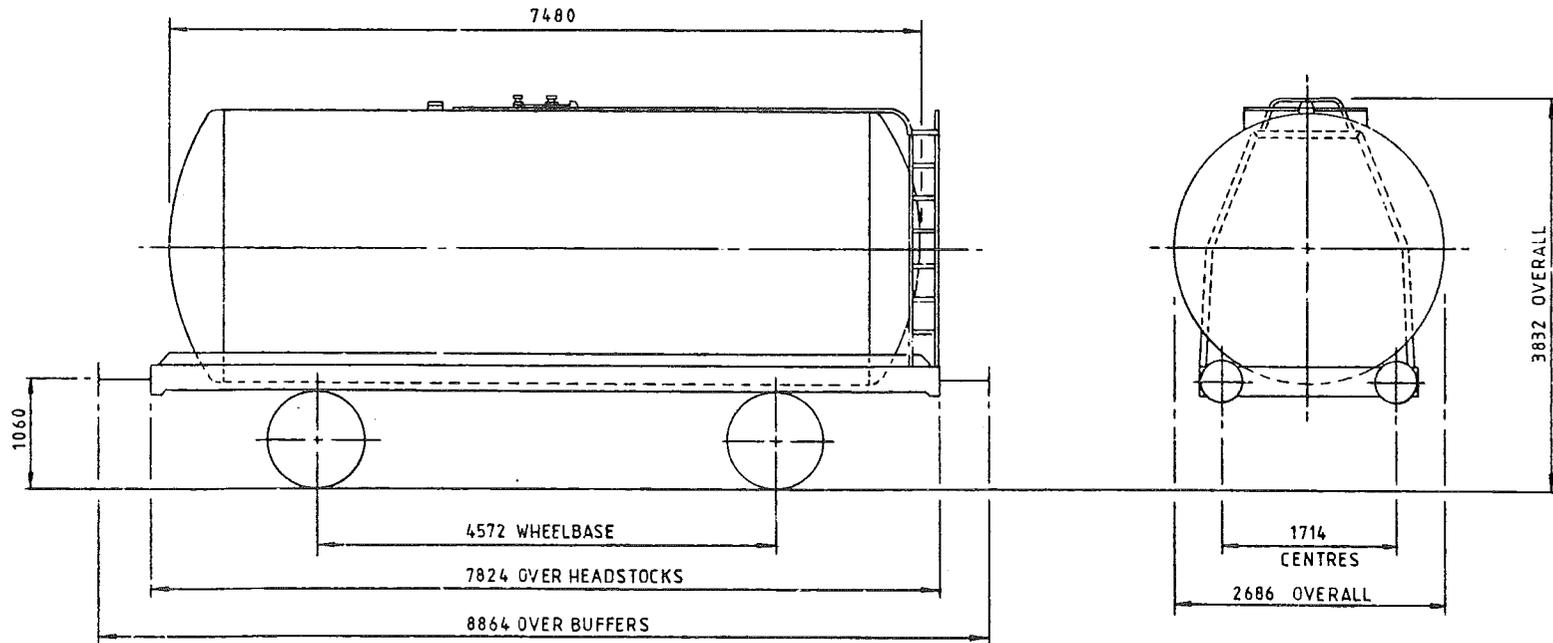

TARE-	12,550 Kg.
CAPACITY, WEIGHT-	33,450 Kg
CAPACITY, VOLUME-	38,359 litres
MIN. CURVE-	31m
GEN. ARRGT. DRG. NO.-	

BRAKE-	AIR BLOCK & HAND LEVER
SUSPENSION-	DOUBLE LINK & PARABOLIC SPRING
COUPLINGS-	INSTANTER
BUFFERS-	HYDRAULIC 406 DIA. HEADS
WHEELS-	952 DIA.
JOURNALS-	140 DIA. ROLLER BEARINGS

ISSUE 1

46 tonne GLW TANK WAGON—CLASS 'B'

LOT NUMBER	

TOPS INFORMATION								
AARKND	OPERATING	OPERATING SPEED		BRAKE FORCE DATA		EXCESS	RA	DESIGN
CARKND	PANEL No.	60 mile/h UP TO		5 t FORCE UP TO		LENGTH	(GLW)	SHEET
T T A A		46 tonne GLW		23 t FORCE ABOVE		4	8	W1229
		mile/h ABOVE		28 tonne GLW				

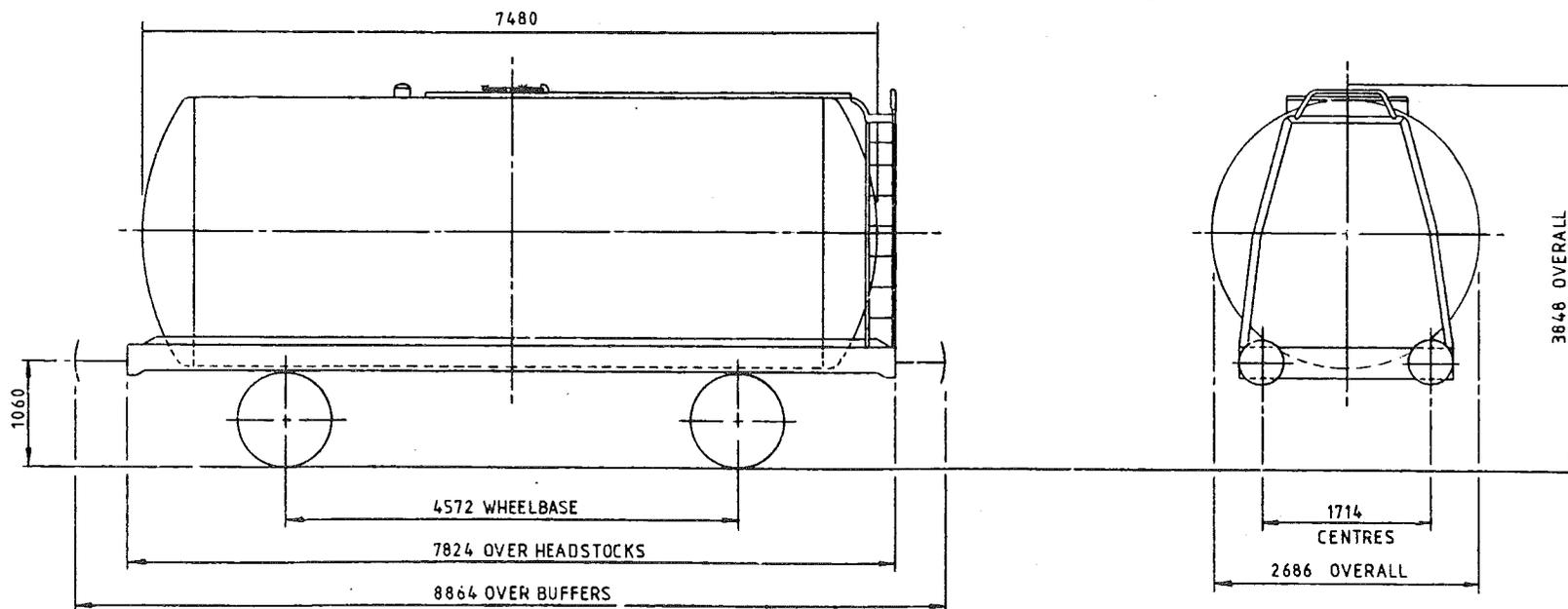

TARE-	12,400 Kg
CAPACITY, WEIGHT-	33600 Kg
CAPACITY, VOLUME-	34,804 l BUTANE 38,636 l KERO-GAS OIL
MIN. CURVE-	31m
GEN. ARRGT. DRG. NO.-	

BRAKE-	AIR BLOCK & HAND LEVER
SUSPENSION-	DOUBLE LINK & PARABOLIC SPRING
COUPLINGS-	INSTANTER
BUFFERS-	HYDRAULIC 406 DIA. HEADS
WHEELS-	952 DIA.
JOURNALS-	140 DIA. ROLLER BEARINGS

ISSUE 1

46 tonne GLW TANK WAGON-CLASS 'A'

LOT NUMBER	

TOPS INFORMATION											
AARKND		OPERATING		OPERATING SPEED			BRAKE FORCE DATA		EXCESS LENGTH	RA (GLW)	DESIGN SHEET
CARKND	PANEL No.	60 mile/h UP TO 46 tonne GLW			7t FORCE UP TO 28t FORCE ABOVE 31 tonne GLW		4	9	W1194		
T T A A		mile/h ABOVE									

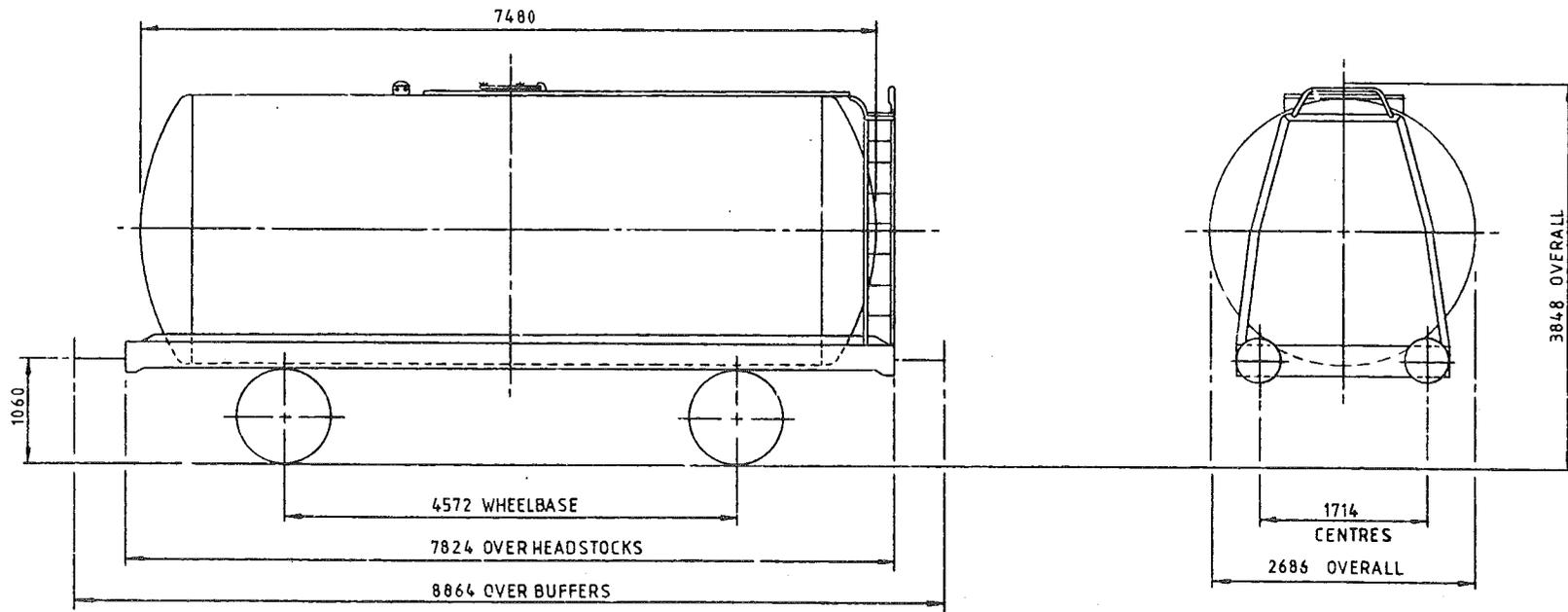

TARE-	12,600 Kg
CAPACITY, WEIGHT-	33,400 Kg
CAPACITY, VOLUME-	39,436 litres
MIN. CURVE-	31m
GEN. ARRGT. DRG. NO.-	

BRAKE-	AIR BLOCK & HAND LEVER
SUSPENSION-	DOUBLE LINK & PARABOLIC SPRING
COUPLINGS-	INSTANTER
BUFFERS-	HYDRAULIC 406 DIA. HEADS
WHEELS-	952 DIA.
JOURNALS-	140 DIA. ROLLER BEARINGS

ISSUE 1

46 tonne GLW TANK WAGON-CLASS 'A'

LOT NUMBER	

TOPS INFORMATION								
AARKND	OPERATING	OPERATING SPEED		BRAKE FORCE DATA		EXCESS LENGTH	RA (GLW)	DESIGN SHEET
CARKND	PANEL No.	60 mile/h UP TO 46 tonne GLW		7t FORCE UP TO 28t FORCE ABOVE 31 tonne GLW		4	9	WI222
T T A A		mile/h ABOVE						

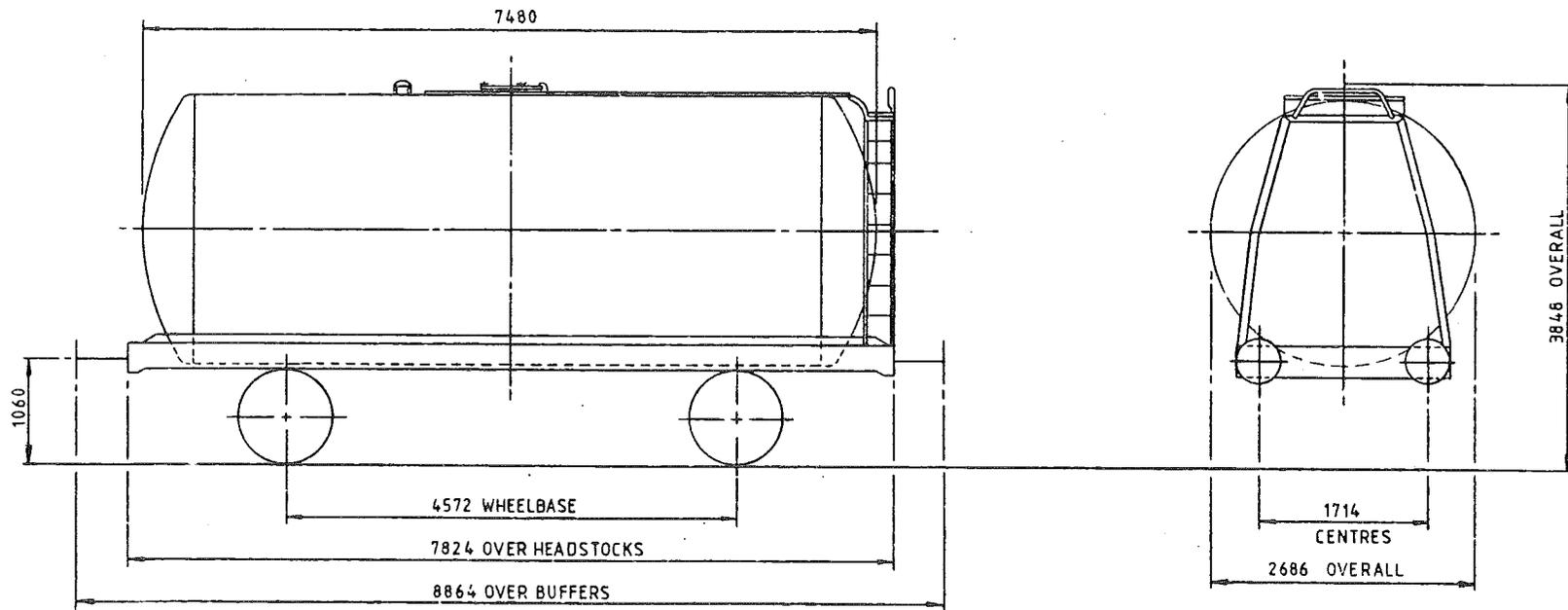

TARE-	12.600 Kg
CAPACITY, WEIGHT-	33400 Kg
CAPACITY, VOLUME-	37.881 PETROL 38.468 KERO-GAS OIL
MIN. CURVE-	31m
GEN. ARRGT. DRG. NO.-	

BRAKE-	AIR BLOCK & HAND LEVER
SUSPENSION-	DOUBLE LINK & PARABOLIC SPRING
COUPLINGS-	INSTANTER
BUFFERS-	HYDRAULIC 406 DIA. HEADS
WHEELS-	952 DIA.
JOURNALS-	140 DIA. ROLLER BEARINGS

ISSUE 1

46 tonne GLW TANK WAGON-CLASS 'A'

LOT NUMBER	

TOPS INFORMATION										
AARKND	OPERATING			OPERATING SPEED		BRAKE FORCE DATA		EXCESS LENGTH	RA (GLW)	DESIGN SHEET
CARKND	PANEL No.			60 mile/h UP TO		6t FORCE UP TO		4	9	W1223
T T A A				mile/h ABOVE 46 tonne GLW		26t FORCE ABOVE 30 tonne GLW				

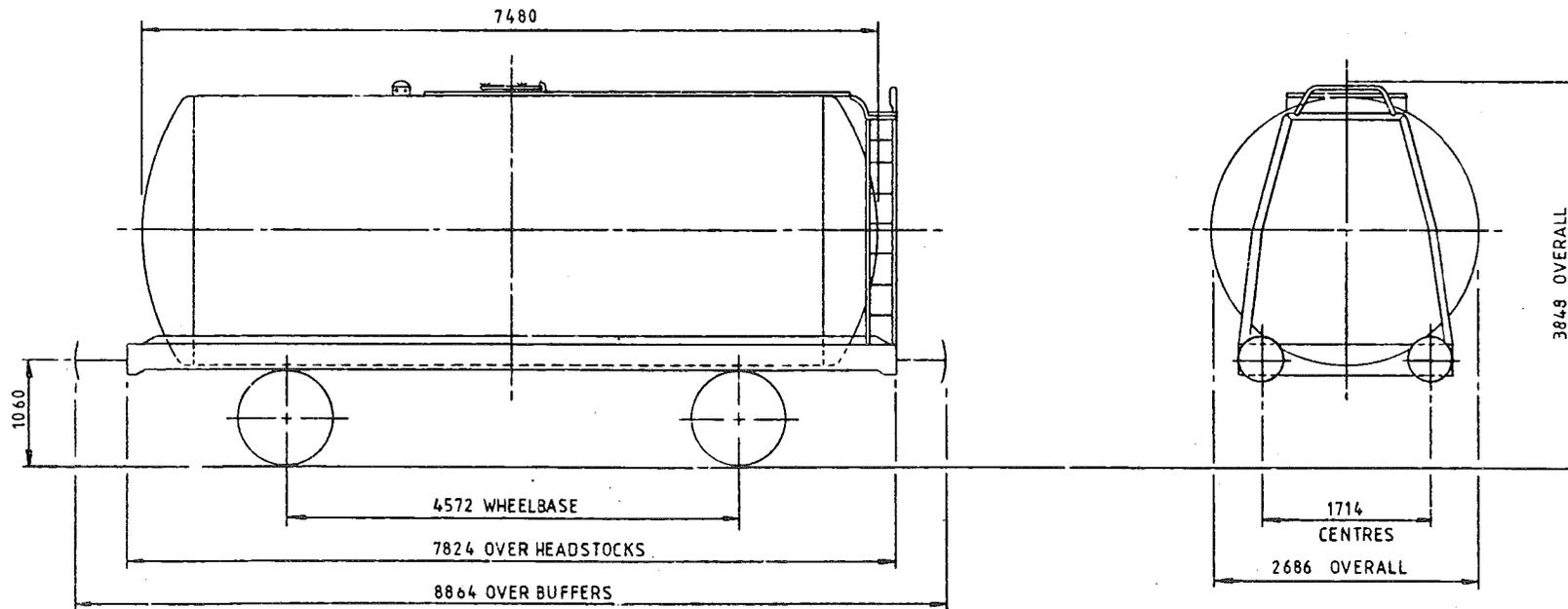

TARE-	12.600 Kg
CAPACITY, WEIGHT-	33400 Kg
CAPACITY, VOLUME-	37.854 PETROL 38440 KERO-GAS OIL
MIN. CURVE-	31m
GEN. ARRGT. DRG. NO.-	

BRAKE-	AIR BLOCK & HAND LEVER
SUSPENSION-	DOUBLE LINK & PARABOLIC SPRING
COUPLINGS-	INSTANTER
BUFFERS-	HYDRAULIC 406 DIA. HEADS
WHEELS-	952 DIA.
JOURNALS-	140 DIA. ROLLER BEARINGS

ISSUE 1

46 tonne GLW TANK WAGON

LOT NUMBER	

TOPS INFORMATION									
AARKND	OPERATING		OPERATING SPEED		BRAKE FORCE DATA		EXCESS LENGTH	RA (GLW)	DESIGN SHEET
CARKND	PANEL No.		60 mile/h UP TO	46 tonne GLW	5t FORCE UP TO	28 tonne GLW			
T	T	A	A				4	8	W1230

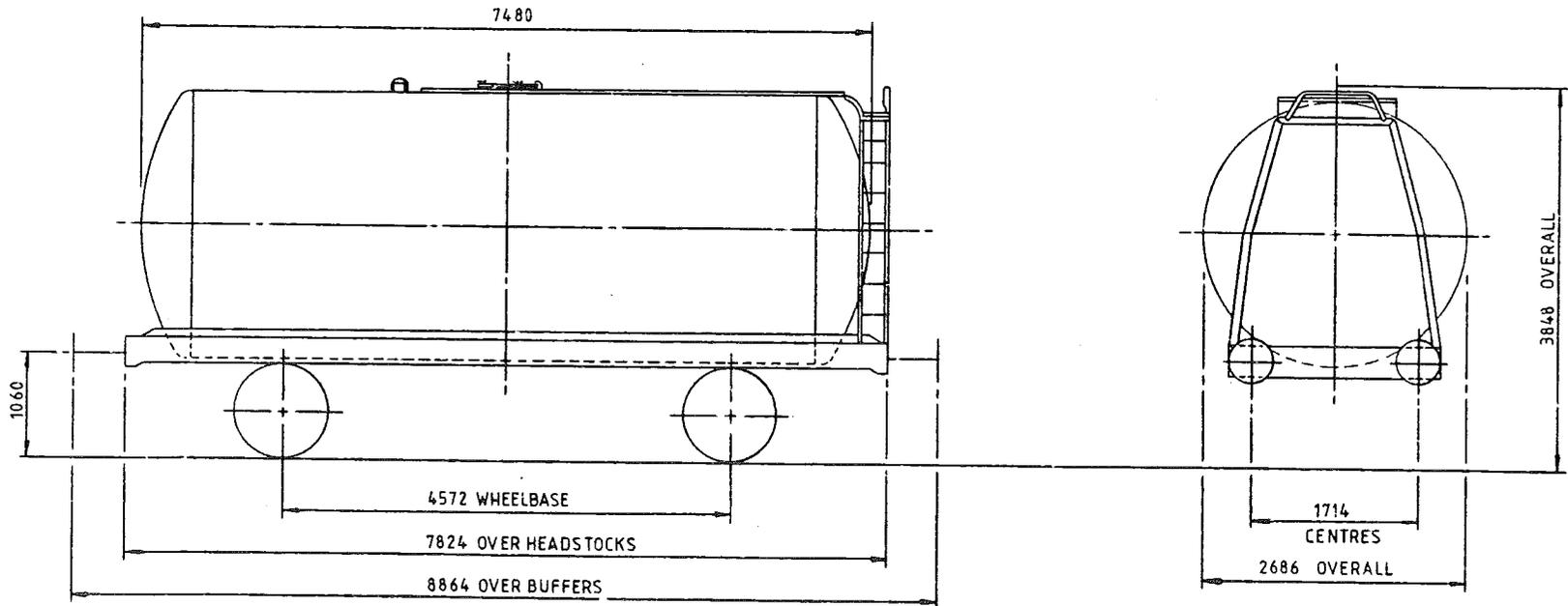

TARE-	12,450 Kg
CAPACITY, WEIGHT-	33,500 Kg
CAPACITY, VOLUME-	34,840 l BRITOL 38,636 l KERO-GAS OIL
MIN. CURVE-	31m
GEN. ARRGT. DRG. NO.-	

BRAKE-	AIR BLOCK & HAND LEVER
SUSPENSION-	DOUBLE LINK & PARABOLIC SPRING
COUPLINGS-	INSTANTER
BUFFERS-	HYDRAULIC 406 DIA. HEADS
WHEELS-	952 DIA.
JOURNALS-	140 DIA. ROLLER BEARINGS

ISSUE 1

46 tonne GLW TANK WAGON-CLASS 'A'

LOT NUMBER	

TOPS INFORMATION						
AARKND	OPERATING	OPERATING SPEED		BRAKE FORCE DATA		EXCESS LENGTH
CARKND	PANEL No.	45 mile/h UP TO	13 tonne GLW	10t FORCE UP TO	3 tonne GLW	RA (GLW)
T T A A		60 mile/h ABOVE		22t FORCE ABOVE		9
						DESIGN SHEET
						W1245

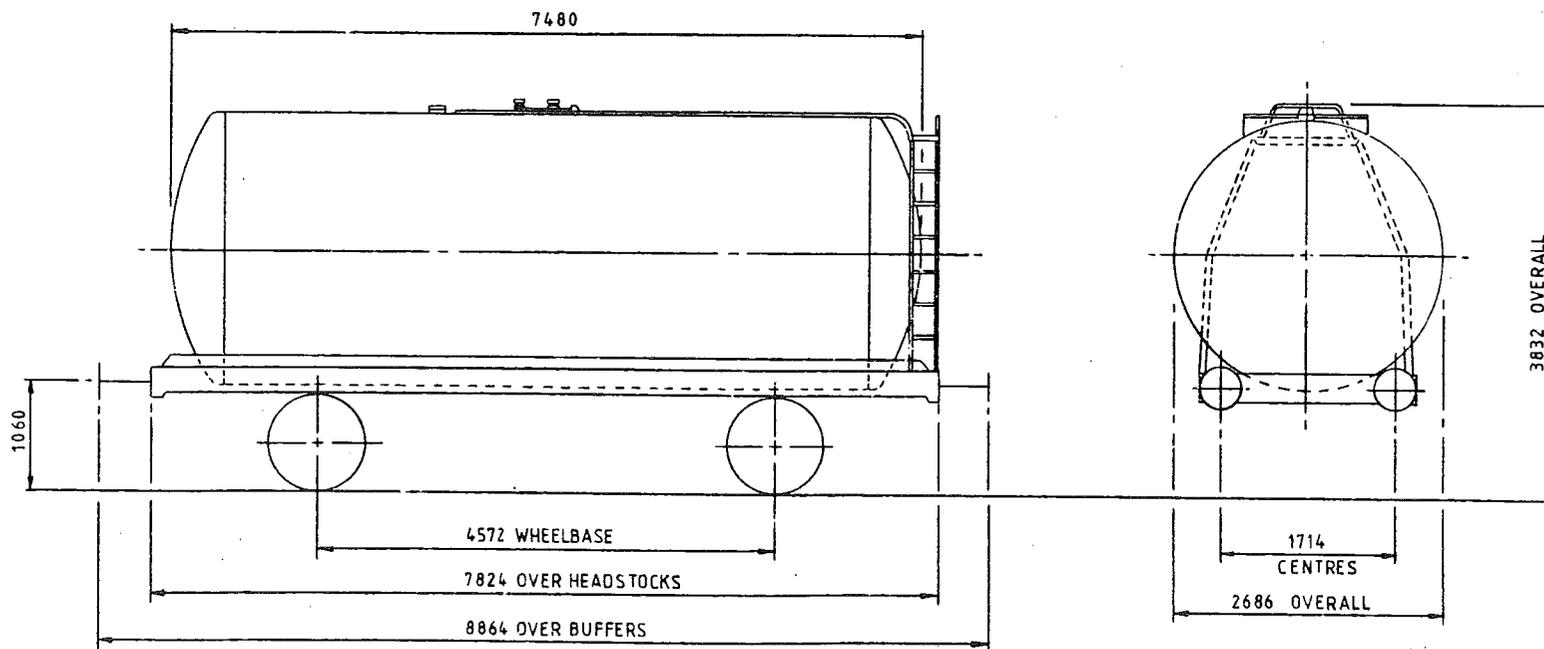

TARE-	13.000 Kg
CAPACITY, WEIGHT-	33000 Kg
CAPACITY, VOLUME-PETROL	38154 l
KERO-GAS OIL	38745 l
MIN. CURVE-	31m
GEN. ARRGT. DRG. NO.-	

BRAKE-	AIR BLOCK & HAND LEVER
SUSPENSION-	DOUBLE LINK
COUPLINGS-	INSTANTER
BUFFERS-	HYDRAULIC 406 DIA. HEADS
WHEELS-	952 DIA.
JOURNALS-	140 DIA. ROLLER BEARINGS

ISSUE 1

46 tonne GLW TANK WAGON-CLASS 'A'

LOT NUMBER	

TOPS INFORMATION								
AARKND	OPERATING	OPERATING SPEED		BRAKE FORCE DATA		EXCESS LENGTH	RA (GLW)	DESIGN SHEET
CARKND	PANEL No.	45 mile/h UP TO	13 tonne GLW	10t FORCE UP TO	31tonne GLW	4	9	W1267
T T A A		60 mile/h ABOVE		22t FORCE ABOVE				

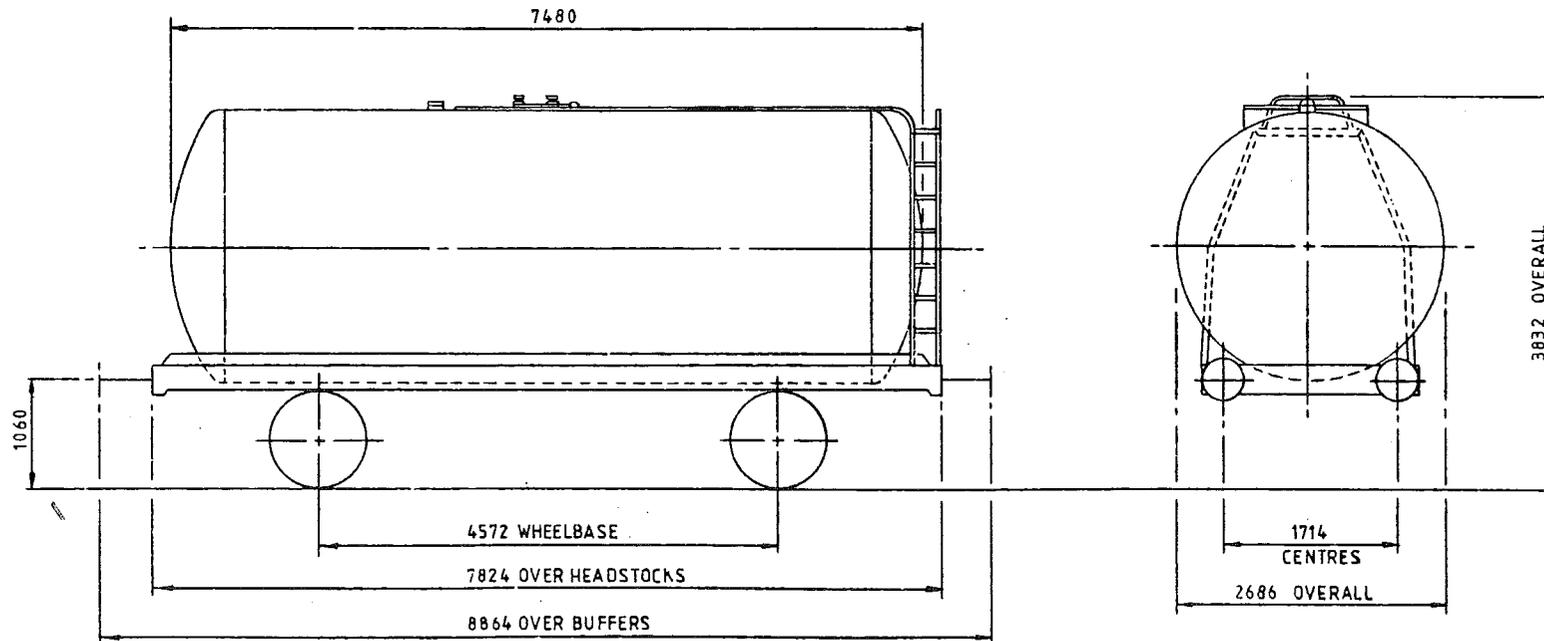

TARE-	13,000 Kg
CAPACITY, WEIGHT-	33,000 Kg
CAPACITY, VOLUME-	38,359 litres
MIN. CURVE-	31m
GEN. ARRGT. DRG. NO.-	

BRAKE-	AIR BLOCK & HAND LEVER
SUSPENSION-	DOUBLE LINK
COUPLINGS-	INSTANTER
BUFFERS-	HYDRAULIC 406 DIA. HEADS
WHEELS-	952 DIA.
JOURNALS-	140 DIA. ROLLER BEARINGS

ISSUE 1

46 tonne GLW TANK WAGON—CLASS 'A'

LOT NUMBER	

TOPS INFORMATION										
AARKNG		OPERATING		OPERATING SPEED		BRAKE FORCE DATA		EXCESS LENGTH	RA (GLW)	DESIGN SHEET
CARKND	PANEL No.	60 mile/h UP TO		46 tonne GLW		5t FORCE UP TO		4	9	W1297
T T A A		mile/h ABOVE				30.5tonne GLW				

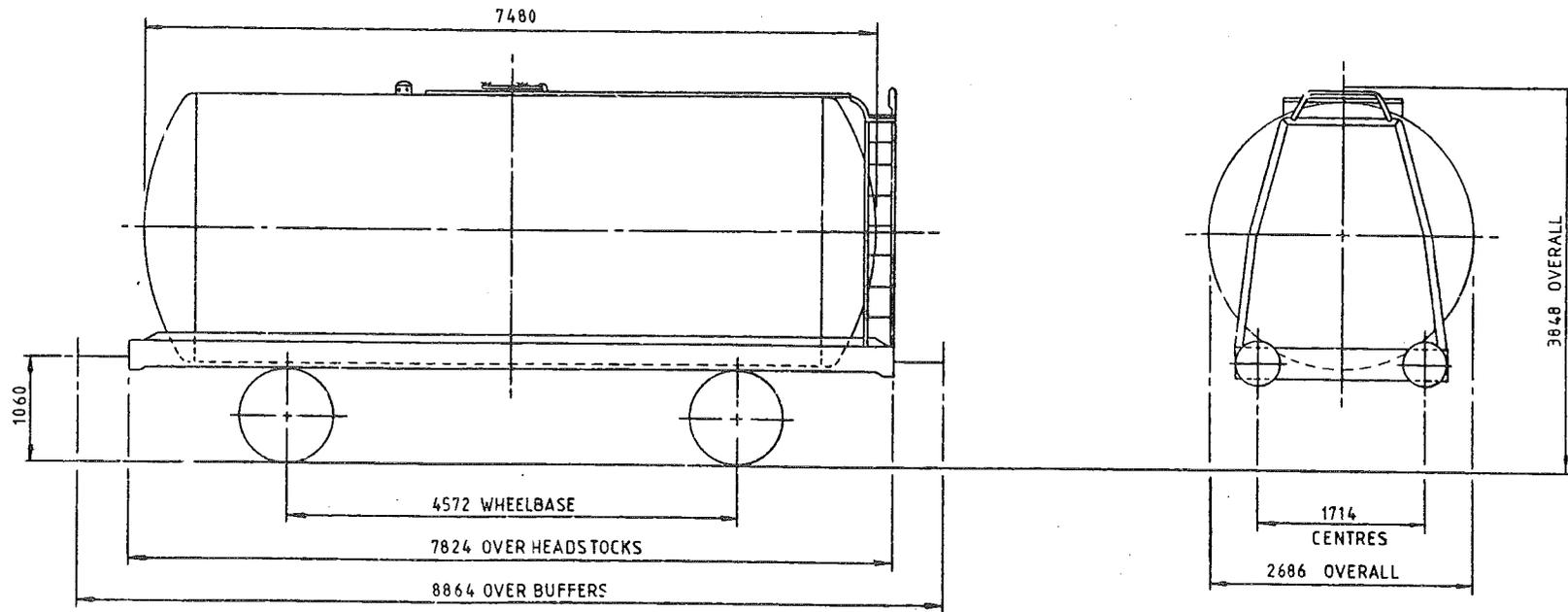

TARE-	12,800 Kg
CAPACITY, WEIGHT-	33,200 Kg
CAPACITY, VOLUME-	39,436 litres
MIN. CURVE-	31m
GEN. ARRGT. DRG. NO.-	

BRAKE-	AIR BLOCK & HAND LEVER
SUSPENSION-	DOUBLE LINK & PARABOLIC SPRING
COUPLINGS-	INSTANTER
BUFFERS-	HYDRAULIC 406 DIA. HEADS
WHEELS-	952 DIA.
JOURNALS-	140 DIA. ROLLER BEARINGS

ISSUE 1

46 tonne GLW TANK WAGON-CLASS 'A'

LOT NUMBER	

TOPS INFORMATION										
AARKND	OPERATING			OPERATING SPEED		BRAKE FORCE DATA		EXCESS LENGTH	RA (GLW)	DESIGN SHEET
CARKND	PANEL No.			60 mile/h UP TO	46 tonne GLW	10t FORCE UP TO	31 tonne GLW	4	8	W1303
T T A A				mile/h ABOVE		22t FORCE ABOVE				

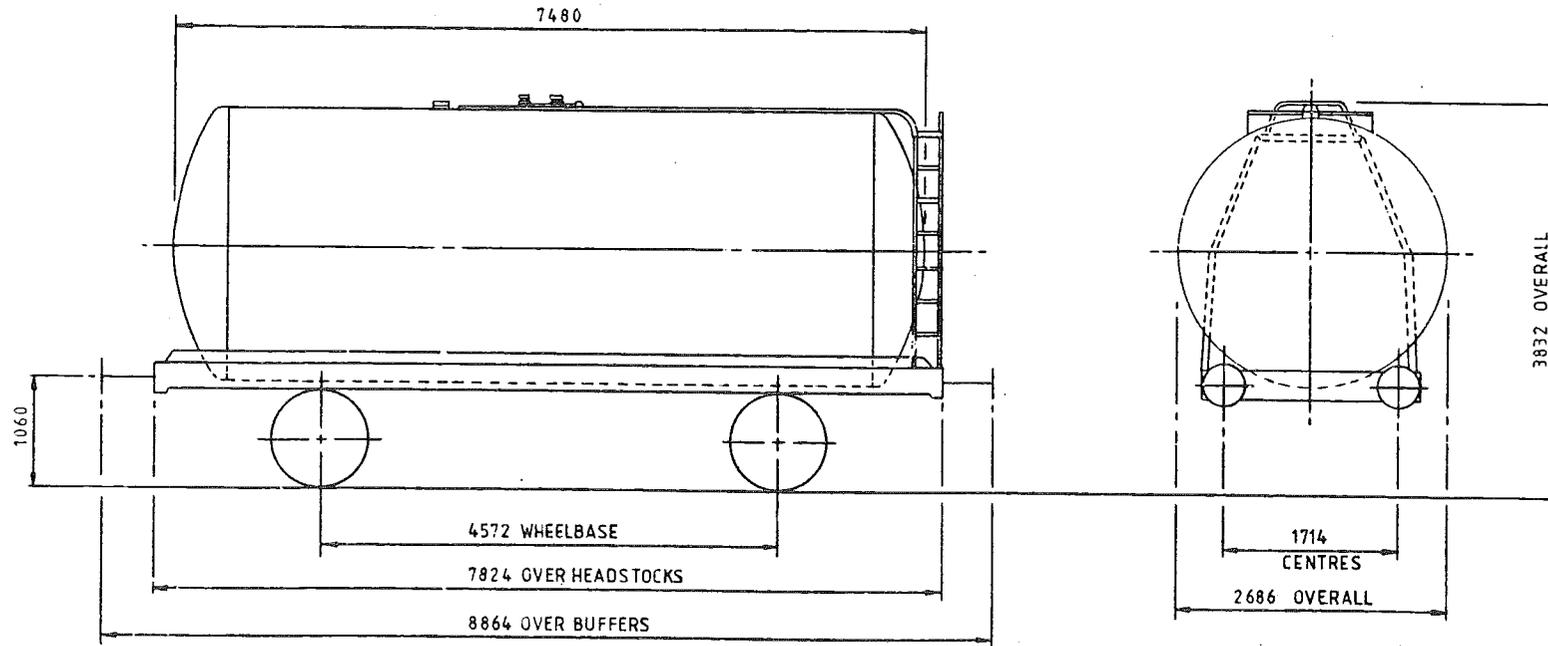

TARE-	12.750 Kg
CAPACITY, WEIGHT-	33250 Kg
CAPACITY, VOLUME-	39.414 litres
MIN. CURVE-	31m
GEN. ARRGT. DRG. NO.-	

BRAKE-	AIR BLOCK & HAND LEVER
SUSPENSION-	SINGLE LINK & PARABOLIC SPRING
COUPLINGS-	INSTANTER
BUFFERS-	HYDRAULIC 406 DIA. HEADS
WHEELS-	952 DIA.
JOURNALS-	140 DIA. ROLLER BEARINGS

ISSUE 1

46 tonne GLW TANK WAGON-CLASS 'A'

LOT NUMBER	

TOPS INFORMATION									
AARKND	OPERATING		OPERATING SPEED		BRAKE FORCE DATA		EXCESS LENGTH	RA (GLW)	DESIGN SHEET
CARKND	PANEL No.		60 mile/h UP TO	46 tonne GLW	10t FORCE UP TO	31 tonne GLW			
T T A A			mile/h ABOVE		22t FORCE ABOVE		4	8	W1304

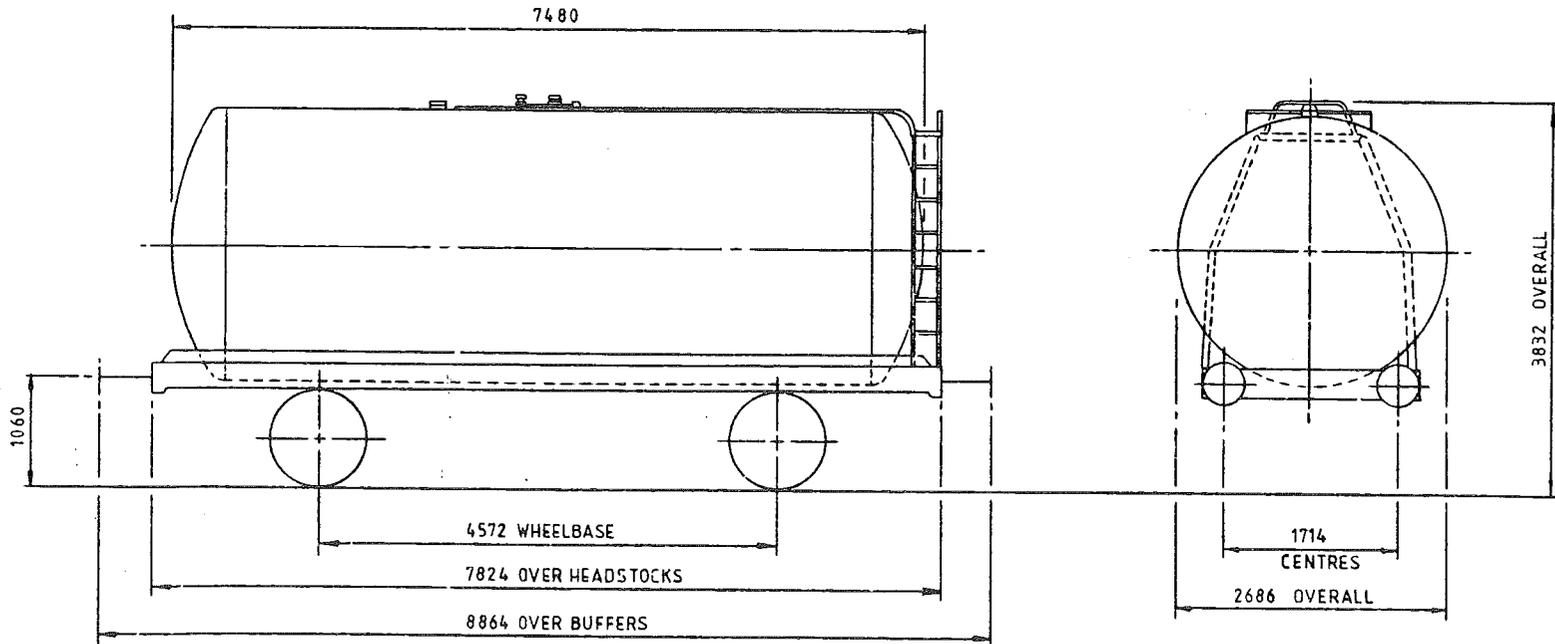

TARE-	12,850 Kg
CAPACITY, WEIGHT-	33,150 Kg
CAPACITY, VOLUME-PETROL	38,154 l
KERO-GAS OIL	38,745 l
MIN. CURVE-	31m
GEN. ARRGT. DRG. NO.-	

BRAKE-	AIR BLOCK & HAND LEVER
SUSPENSION-	SINGLE LINK & PARABOLIC SPRING
COUPLINGS-	INSTANTER
BUFFERS-	HYDRAULIC 406 DIA. HEADS
WHEELS-	952 DIA.
JOURNALS-	140 DIA. ROLLER BEARINGS

ISSUE 1

46 tonne GLW TANK WAGON—CLASS 'A'

LOT NUMBER	

TOPS INFORMATION						
AARKND	OPERATING	OPERATING SPEED		BRAKE FORCE DATA		EXCESS LENGTH
CARKND	PANEL No.	60 mile/h UP TO		5t FORCE UP TO		RA
T T A A		mile/h ABOVE		22t FORCE ABOVE		(GLW)
		46 tonne GLW		30 tonne GLW		4
						8
						WI276

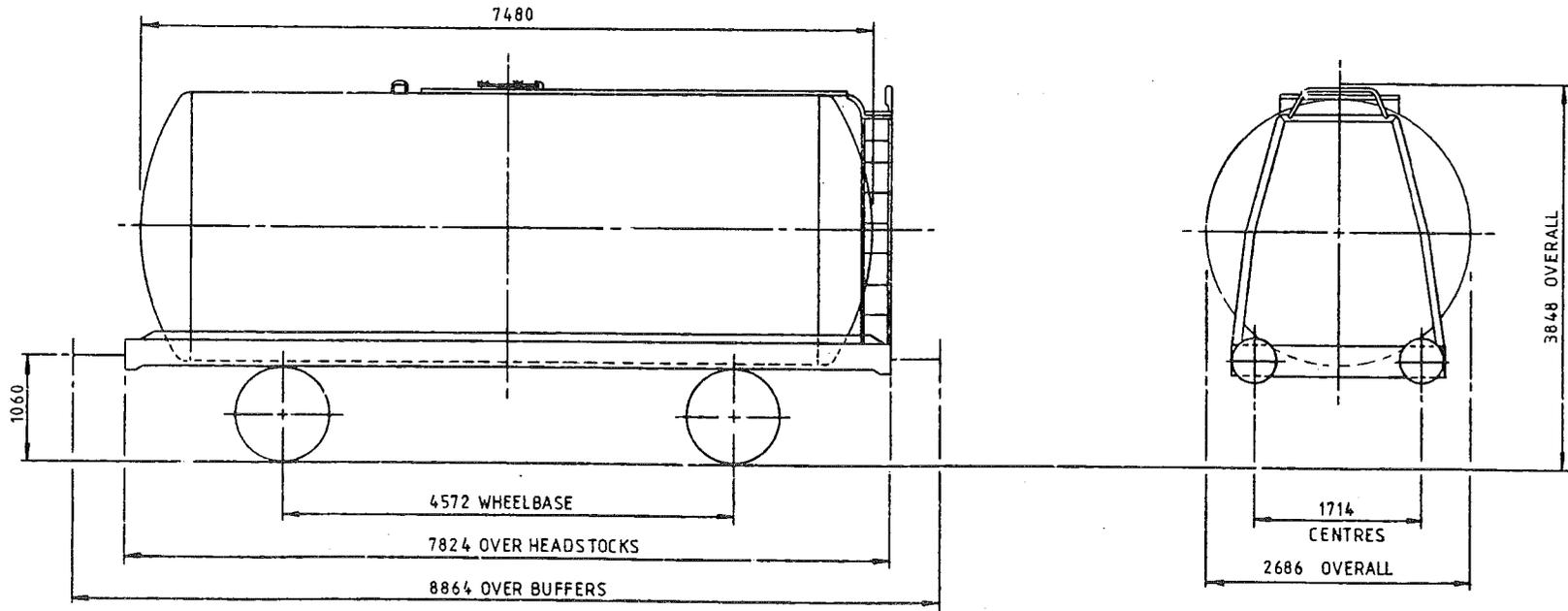

TARE-	12,500 Kg
CAPACITY, WEIGHT-	33,500 Kg
CAPACITY, VOLUME-	37,891 L PETROL 38,468 L KERO-GASOIL
MIN. CURVE-	31m
GEN. ARRGT. DRG. NO.-	

BRAKE-	AIR BLOCK & HAND LEVER
SUSPENSION-	DOUBLE LINK & PARABOLIC SPRING
COUPLINGS-	INSTANTER
BUFFERS-	HYDRAULIC 406 DIA. HEADS
WHEELS-	952 DIA.
JOURNALS-	140 DIA. ROLLER BEARINGS

ISSUE 1

46 tonne GLW TANK WAGON

LOT NUMBER	

TOPS INFORMATION						
AARKND	OPERATING	OPERATING SPEED		BRAKE FORCE DATA		EXCESS LENGTH
CARKND	PANEL No.	60 mile/h UP TO	46 tonne GLW	5 t FORCE UP TO	30 tonne GLW	RA (GLW)
T	T A A			22t FORCE ABOVE		4
						8
						W1278

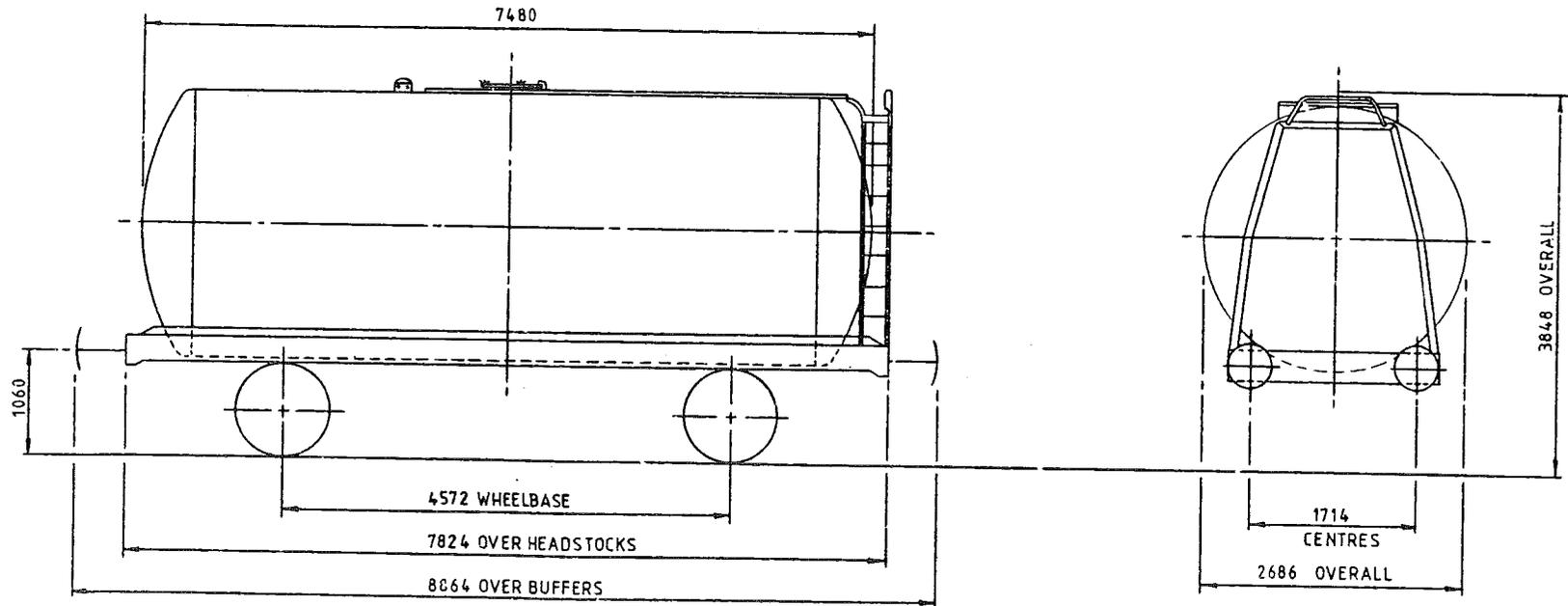

TARE-	12,200 Kg
CAPACITY, WEIGHT-	33,800 Kg
CAPACITY, VOLUME-	37,854 l PETROL 38,440 l KERO-GAS OIL
MIN. CURVE-	31m
GEN. ARRGT. DRG. NO.-	

BRAKE-	AIR BLOCK & HAND LEVER
SUSPENSION-	DOUBLE LINK & PARABOLIC SPRING
COUPLINGS-	INSTANTER
BUFFERS-	HYDRAULIC 406 DIA. HEADS
WHEELS-	952 DIA.
JOURNALS-	140 DIA. ROLLER BEARINGS

ISSUE 1

46 tonne GLW TANK WAGON-CLASS 'A'

LOT NUMBER	

TOPS INFORMATION								
AARKND	OPERATING	OPERATING SPEED		BRAKE FORCE DATA		EXCESS LENGTH	RA (GLW)	DESIGN SHEET
CARKND	PANEL No.	60 mile/h UP TO		5 t FORCE UP TO		4	9	W1313
TTA	A	mile/h ABOVE		22t FORCE ABOVE				

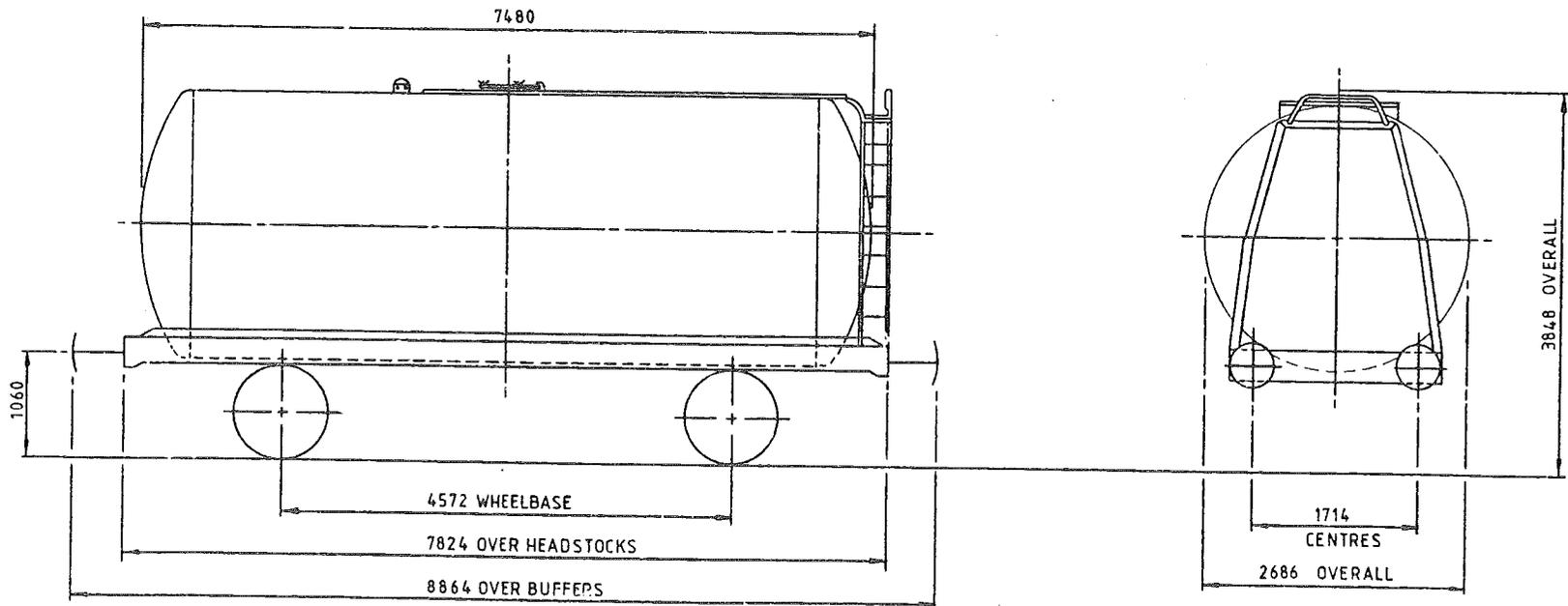

TARE-	12,350 Kg
CAPACITY, WEIGHT-	33650 Kg
CAPACITY, VOLUME-	37.854 (PETROL 38.440) KERO-GASOIL
MIN. CURVE-	31m
GEN. ARRGT. DRG. NO.-	

BRAKE-	AIR BLOCK & HAND LEVER
SUSPENSION-	DOUBLE LINK & PARABOLIC SPRING
COUPLINGS-	INSTANTER
BUFFERS-	HYDRAULIC 406 DIA. HEADS
WHEELS-	952 DIA.
JOURNALS-	140 DIA. ROLLER BEARINGS

ISSUE 1

46 tonne GLW TANK WAGON-CLASS 'A'

LOT NUMBER	

TOPS INFORMATION						
AARKND	OPERATING	OPERATING SPEED		BRAKE FORCE DATA		EXCESS LENGTH
CARKND	PANEL No.	45 mile/h UP TO	13.3tonne GLW	8 t FORCE UP TO	28 tonne GLW	RA (GLW)
T T G A		60 mile/h ABOVE		21 t FORCE ABOVE		4
						8
						WI338

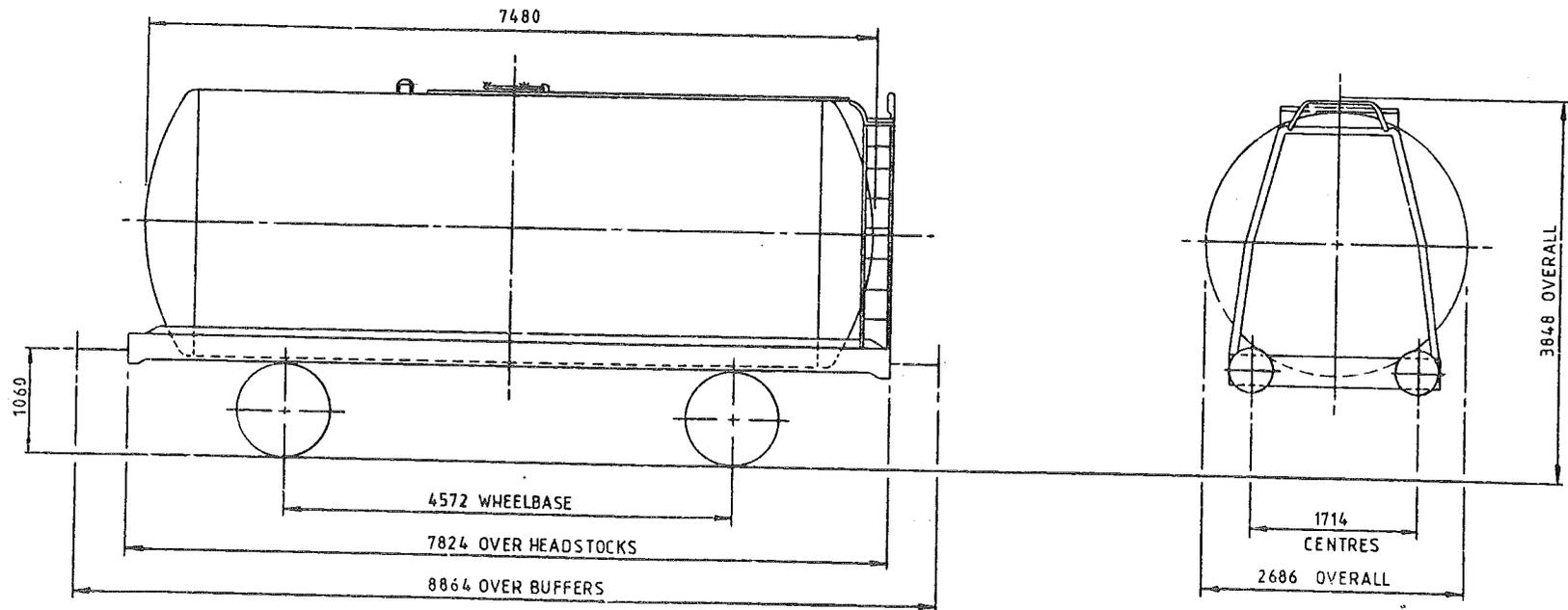

TARE-	13.200 Kg
CAPACITY, WEIGHT-	32.800 Kg
CAPACITY, VOLUME-	37.881 PETROL 38.468 KERO GAS OIL
MIN. CURVE-	31m
GEN. ARRGT. DRG. NO.-	

BRAKE-	VACUUM BLOCK, AIR PIPE & HAND LEVER
SUSPENSION-	DOUBLE LINK
COUPLINGS-	INSTANTER
BUFFERS-	HYDRAULIC 406 DIA. HEADS
WHEELS-	952 DIA.
JOURNALS-	140 DIA. ROLLER BEARINGS

ISSUE 1

46 tonne GLW TANK WAGON-CLASS 'B'

LOT NUMBER	

TOPS INFORMATION								
AARKND	OPERATING	OPERATING SPEED		BRAKE FORCE DATA		EXCESS LENGTH	RA (GLW)	DESIGN SHEET
CARKND	PANEL No.	40 mile/h UP TO	133 tonne GLW	8 t FORCE UP TO	28 tonne GLW	4	8	W1336
T T G A		60 mile/h ABOVE		21 t FORCE ABOVE				

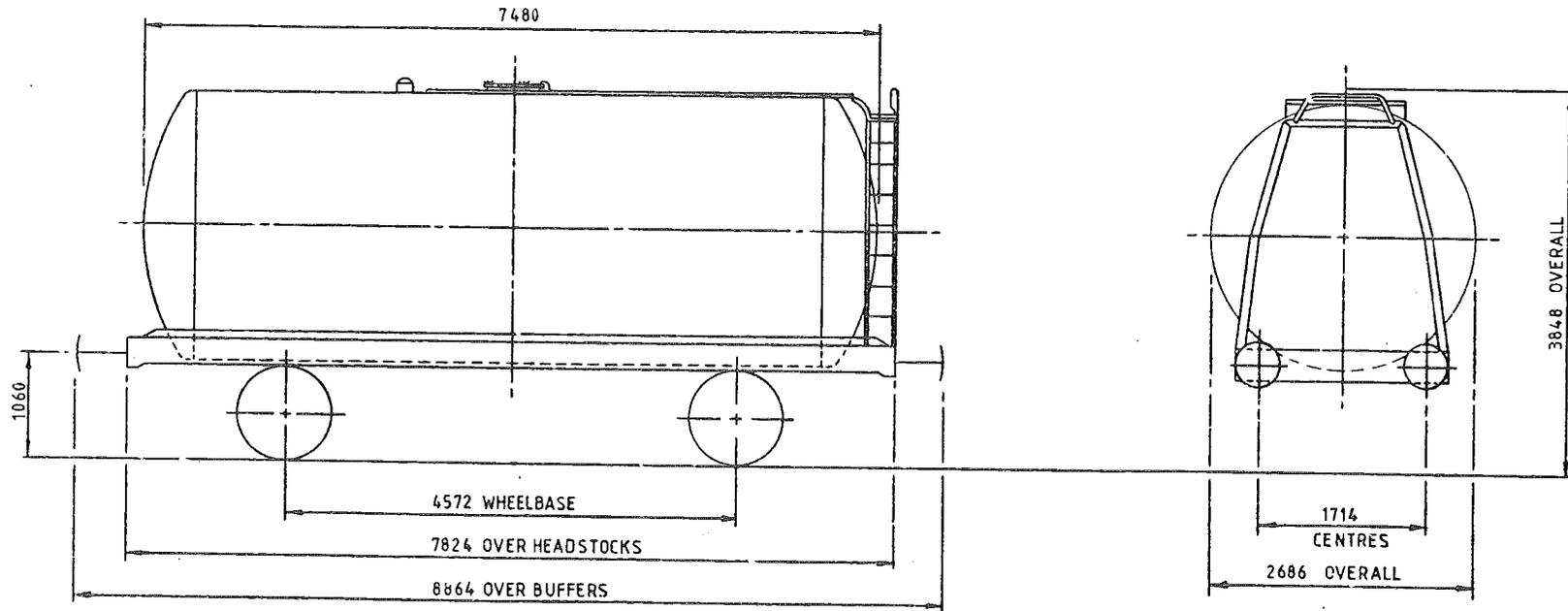

TARE-	13.300 Kg
CAPACITY, WEIGHT-	32.700 Kg
CAPACITY, VOLUME-	34.804 t BUTANE 38.636 t KERO-GAS OIL.
MIN. CURVE-	31m
GEN. ARRGT. DRG. NO.-	

BRAKE-	VACUUM BLOCK, THROUGH AIR PIPE & HAND LEVER
SUSPENSION-	DOUBLE LINK
COUPLINGS-	INSTANTER
BUFFERS-	HYDRAULIC 406 DIA. HEADS
WHEELS-	952 DIA.
JOURNALS-	140 DIA ROLLER BEARINGS

ISSUE 1

46 tonne GLW TANK WAGON—CLASS 'B'

LOT NUMBER	

AARKND		OPERATING		OPERATING SPEED		BRAKE FORCE DATA		EXCESS LENGTH	RA (GLW)	DESIGN SHEET
CARKND	PANEL No.									
T	T	A	A	60 mile/h UP TO	46 tonne GLW	5 t FORCE UP TO	30.5 tonne GLW	4	9	W1351
				mile/h ABOVE		24 t FORCE ABOVE				

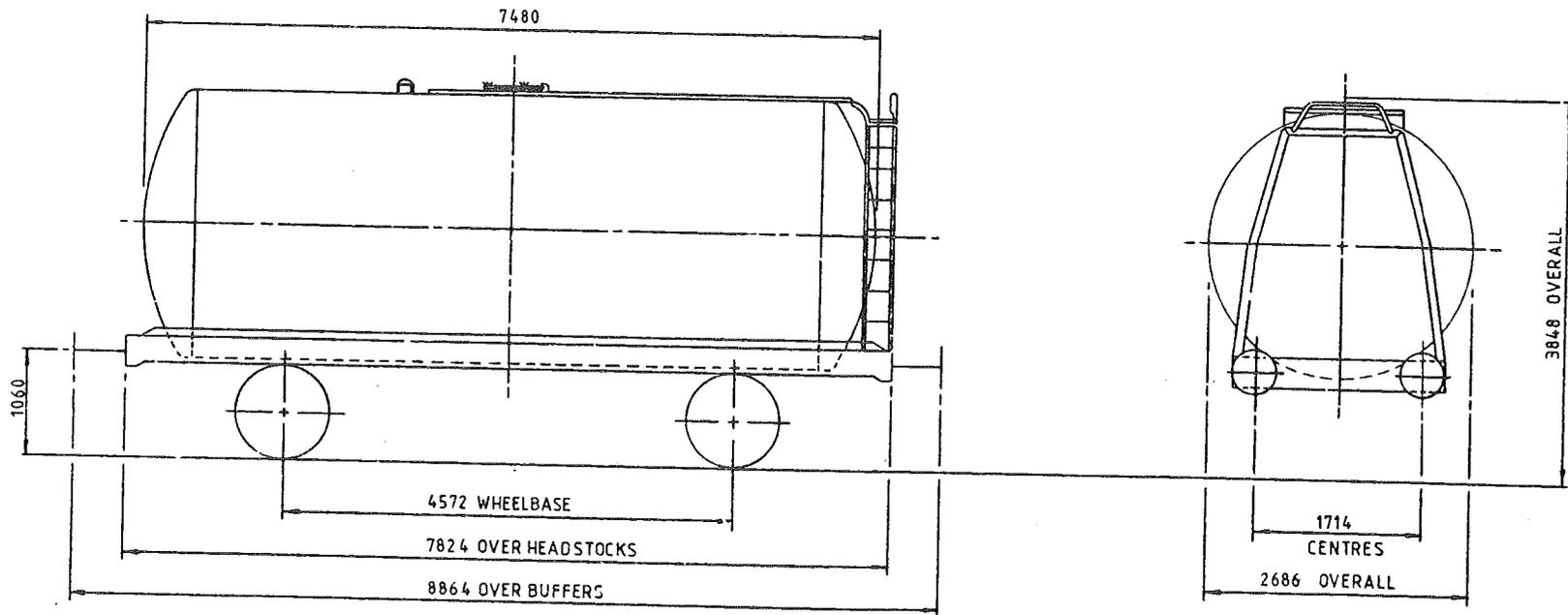

TARE-	12.500 Kg
CAPACITY, WEIGHT-	33.500 Kg
CAPACITY, VOLUME-	34.840 BRITOL 38.636 KERO-GAS OIL
MIN. CURVE-	31m
GEN. ARRGT. DRG. NO.-	

BRAKE-	AIR BLOCK & HAND LEVER
SUSPENSION-	DOUBLE LINK & PARABOLIC SPRING
COUPLINGS-	INSTANTER
BUFFERS-	HYDRAULIC 406 DIA. HEADS
WHEELS-	952 DIA.
JOURNALS-	140 DIA. ROLLER BEARINGS

ISSUE 1

46 tonne GLW TANK WAGON-CLASS 'B'

LOT NUMBER	

TOPS INFORMATION							
AARKND	OPERATING	OPERATING SPEED		BRAKE FORCE DATA	EXCESS LENGTH	RA (GLW)	DESIGN SHEET
CARKND	PANEL No.	60 mile/h UP TO 46 tonne GLW		5t FORCE UP TO 30.5tonne GLW	4	9	WI352
T T A A		mile/h ABOVE		24t FORCE ABOVE			

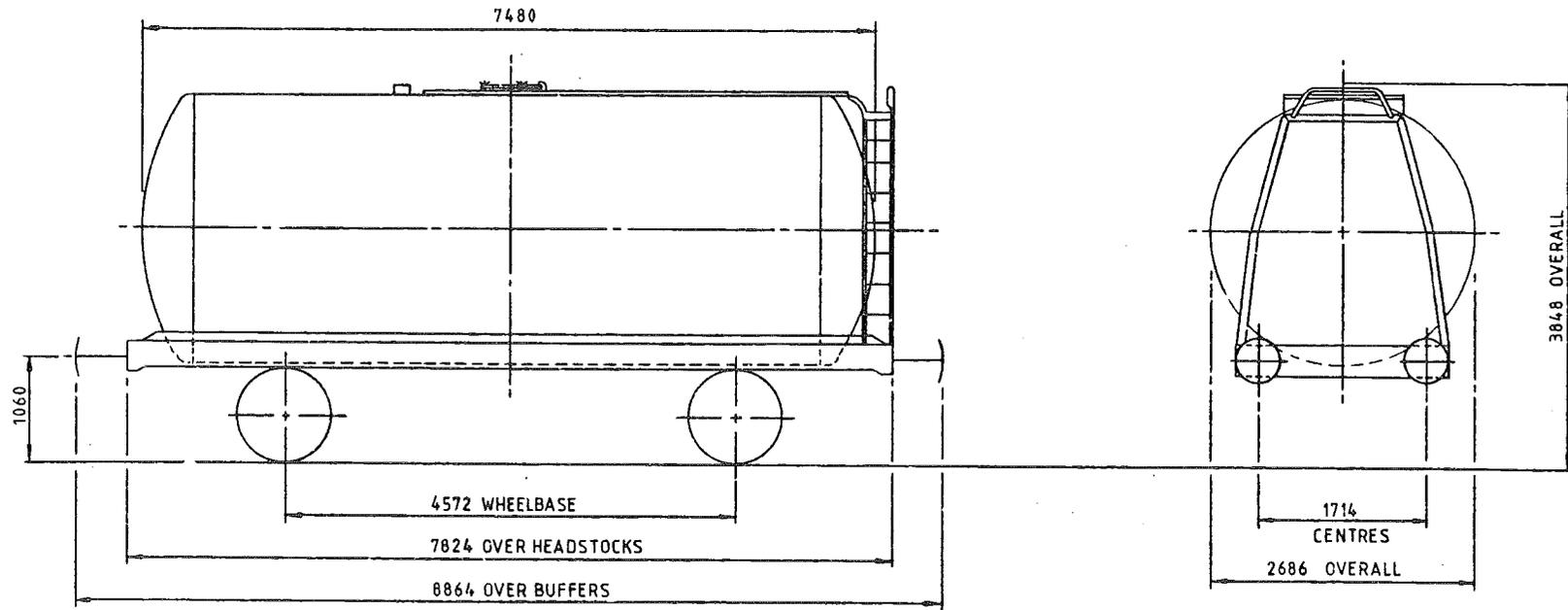

TARE-	12,400 Kg
CAPACITY, WEIGHT-	33,600 Kg
CAPACITY, VOLUME-	34,804 l BUTANE 38,636 l KERO GAS OIL.
MIN. CURVE-	31m
GEN. ARRGT. DRG. NO.-	

BRAKE-	AIR BLOCK & HAND LEVER
SUSPENSION-	DOUBLE LINK & PARABOLIC SPRING
COUPLINGS-	INSTANTER
BUFFERS-	HYDRAULIC 406 DIA. HEADS
WHEELS-	952 DIA.
JOURNALS-	140 DIA. ROLLER BEARINGS

ISSUE 1

42.5 tonne GLW TANK WAGON

LOT NUMBER	

AARKND		OPERATING		OPERATING SPEED		BRAKE FORCE DATA		EXCESS LENGTH	RA (GLW)	DESIGN SHEET
CARKND	PANEL No.	60 mile/h UP TO		42.5 tonne GLW		9 t FORCE UP TO	30 tonne GLW			
T	A	A		mile/h ABOVE		22 t FORCE ABOVE		4	7	WI454

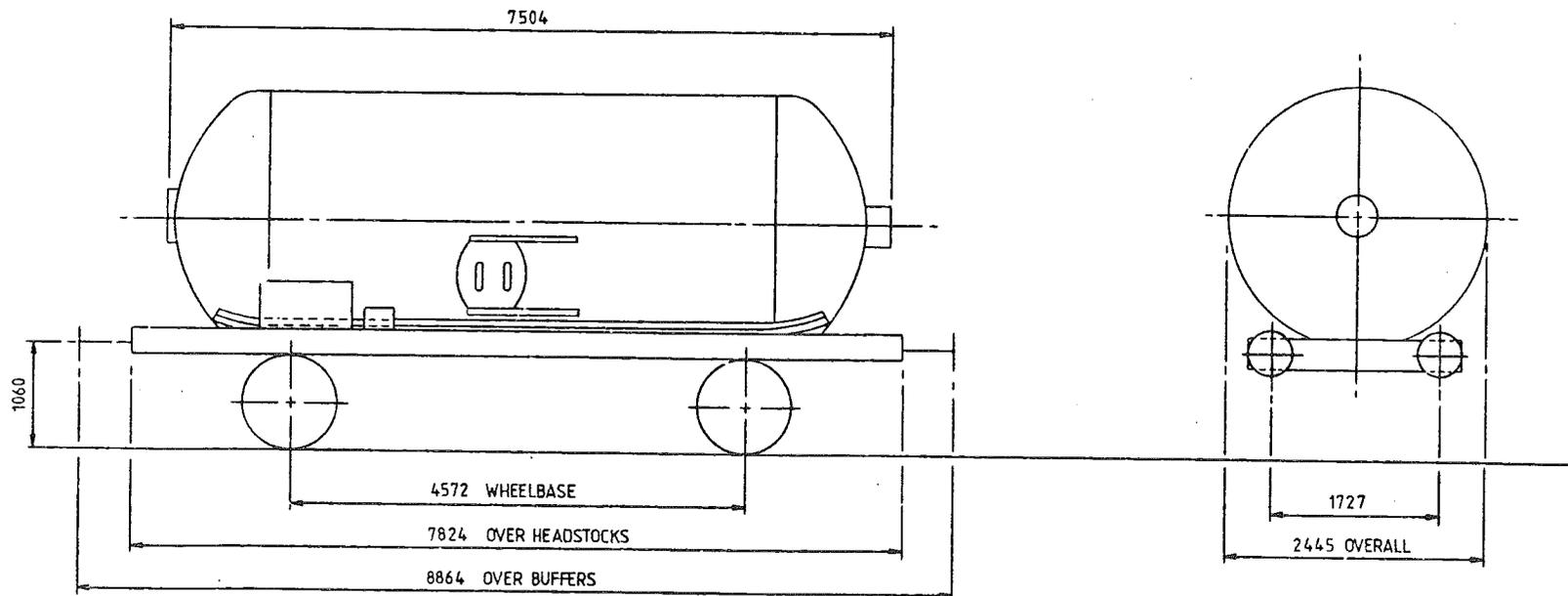

TARE-	22,550 Kg
CAPACITY, WEIGHT-	19,950 Kg
CAPACITY, VOLUME-	32,300 litres
MIN. CURVE-	31 m
GEN. ARRGT. DRG. NO.-	

BRAKE-	AIR BLOCK & HAND LEVER
SUSPENSION-	SINGLE LINK & PARABOLIC SPRING
COUPLINGS-	INSTANTER
BUFFERS-	HYDRAULIC 406 DIA. HEADS
WHEELS-	952 DIA.
JOURNALS-	140 DIA. ROLLER BEARINGS

ISSUE 1

42.5 tonne GLW TANK WAGON

LOT NUMBER	

TOPS INFORMATION										
AARKND	OPERATING PANEL No.			OPERATING SPEED		BRAKE FORCE DATA		EXCESS LENGTH	RA (GLW)	DESIGN SHEET
CARKND				60 mile/h UP TO	42.5 tonne GLW	9 t FORCE UP TO	30 tonne GLW	4	7	WI455
T T A				mile/h ABOVE		22 t FORCE ABOVE				

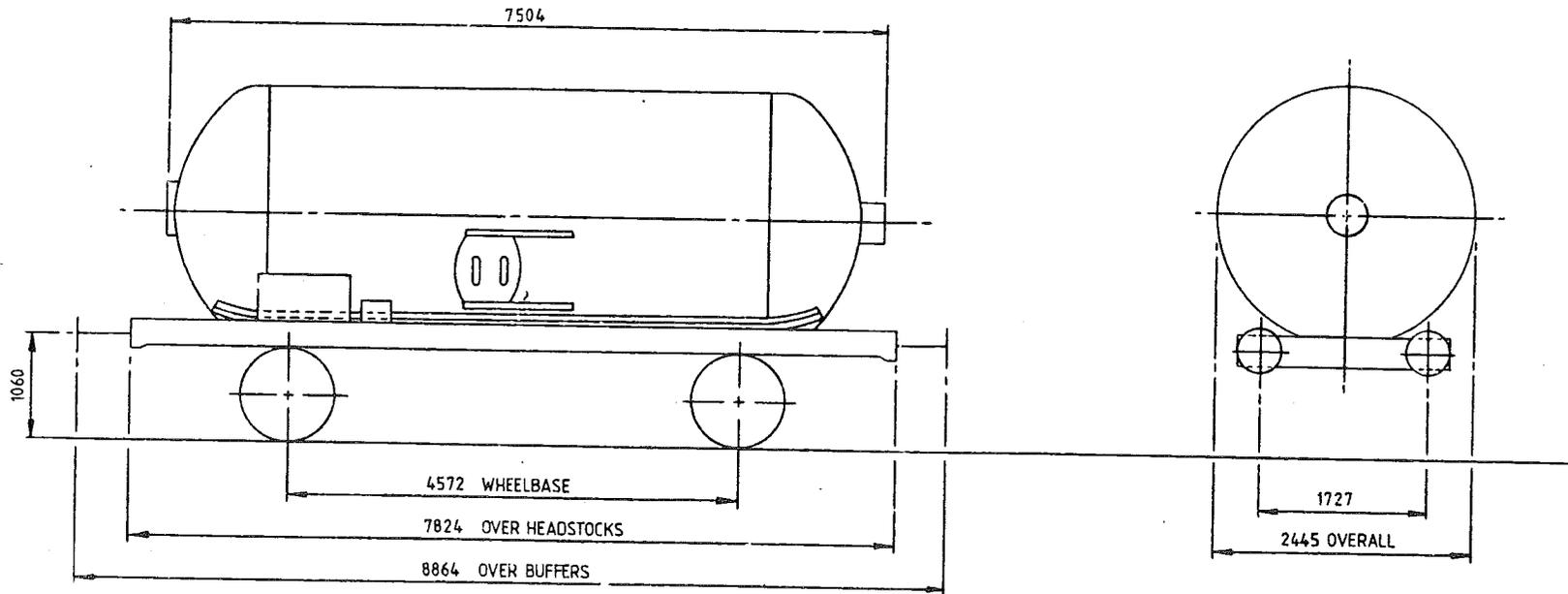

TARE-	22.725 Kg
CAPACITY, WEIGHT-	19.775 Kg
CAPACITY, VOLUME-	32.300 litres
MIN. CURVE-	31 m
GEN. ARRGT. DRG. NO.-	

BRAKE-	AIR BLOCK & HAND LEVER
SUSPENSION-	DOUBLE LINK & PARABOLIC SPRING
COUPLINGS-	INSTANTER
BUFFERS-	HYDRAULIC 406 DIA. HEADS
WHEELS-	952 DIA.
JOURNALS-	140 DIA. ROLLER BEARINGS

ISSUE 1

42.5 tonne GLW TANK WAGON - L.P.G.

LOT NUMBER	

TOPS INFORMATION					
AARKND	OPERATING	OPERATING SPEED		BRAKE FORCE DATA	
CARKND	PANEL No.	60 mile/h UP TO 42.5 tonne GLW		9t FORCE UP TO 30 tonne GLW	
T T A A		mile/h ABOVE		22t FORCE ABOVE	
				EXCESS LENGTH	RA (GLW)
				4	7
					DESIGN SHEET
					W1499

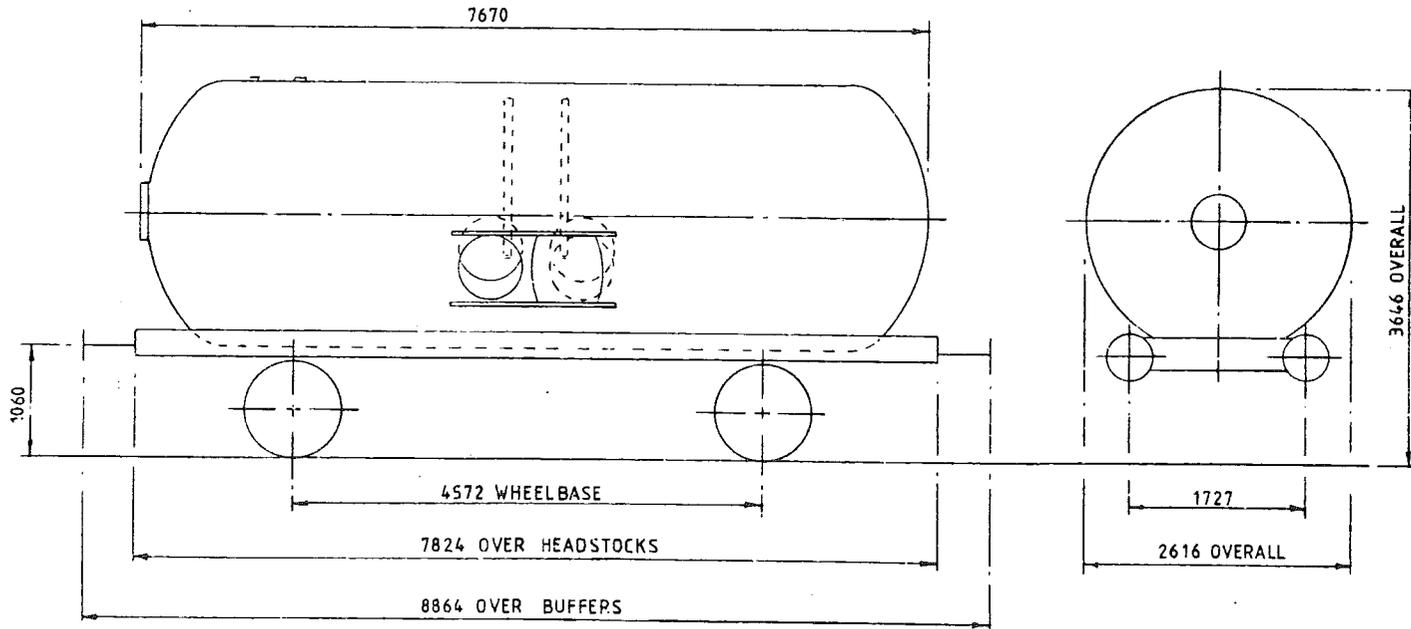

TARE-	22.050 Kg
CAPACITY, WEIGHT-	20.450 Kg
CAPACITY, VOLUME-	15.500 Kg PROPANE, 19.000 Kg BUTANE
MIN. CURVE-	31m
GEN. ARRG. DRG. NO.-	

BRAKE-	AIR BLOCK & HAND LEVER
SUSPENSION-	SINGLE LINK & PARABOLIC SPRING
COUPLINGS-	INSTANTER
BUFFERS-	HYDRAULIC 406 DIA HEADS
WHEELS-	952 DIA
JOURNALS-	140 DIA ROLLER BEARINGS

ISSUE 1

46 tonne GLW TANK WAGON

LOT NUMBER	

TOPS INFORMATION						
AARKND	OPERATING	OPERATING SPEED		BRAKE FORCE DATA		EXCESS
CARKND	PANEL No.	60 mile/h UP TO		9 t FORCE UP TO		LENGTH
T T A A		mile/h ABOVE 46 tonne GLW		22 t FORCE ABOVE 25 tonne GLW		4
						RA
						(GLW)
						DESIGN
						SHEET
						W1516

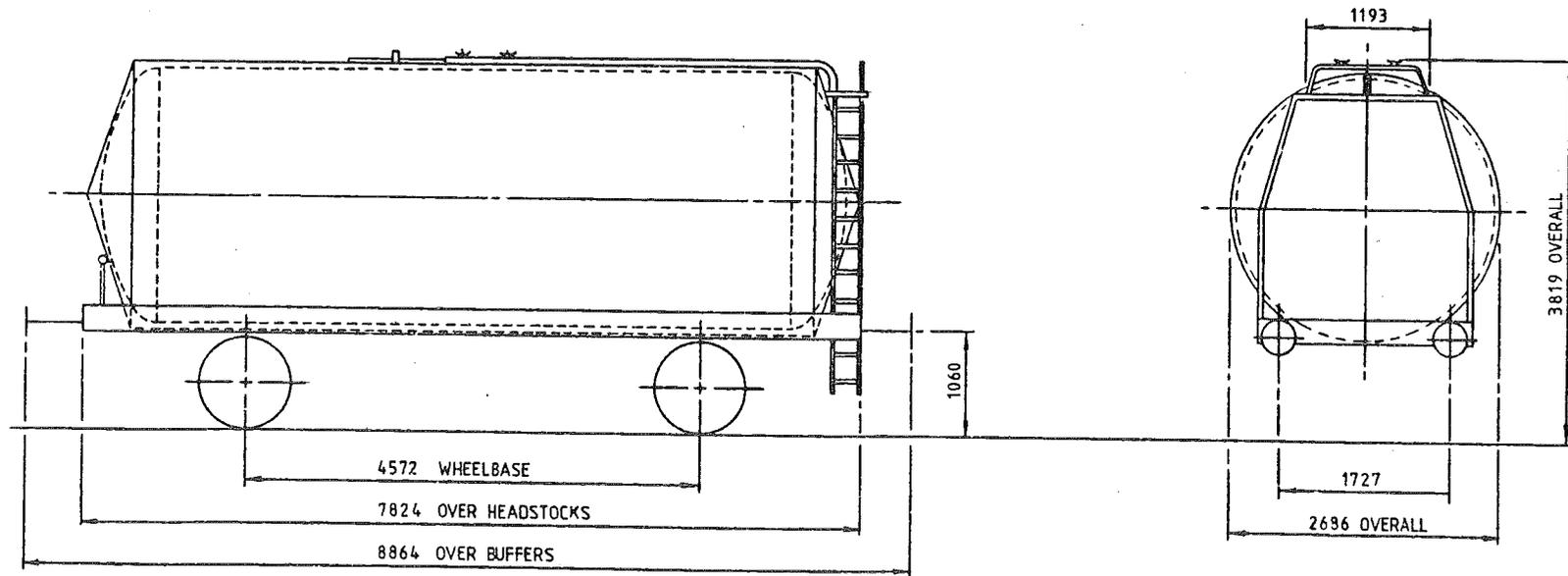

TARE-	13,700 Kg
CAPACITY, WEIGHT-	32,300 Kg
CAPACITY, VOLUME-	35,713 litres
MIN. CURVE-	31 m
GEN. ARRGT. DRG. NO.-	

BRAKE-	AIR BLOCK & HAND LEVER
SUSPENSION-	SINGLE LINK & PARABOLIC SPRING
COUPLINGS-	INSTANTER
BUFFERS-	HYDRAULIC 406 DIA. HEADS
WHEELS-	952 DIA.
JOURNALS-	140 DIA. ROLLER BEARINGS

ISSUE 1

42.5 tonne GLW TANK WAGON—LPG

LOT NUMBER	

TOPS INFORMATION											
AARKND		OPERATING		OPERATING SPEED			BRAKE FORCE DATA		EXCESS LENGTH	RA (GLW)	DESIGN SHEET
CARKND		PANEL No.		60 mile/h UP TO			929 t FORCE UP TO		4	7	WI550
T	T	A	A	42.5 tonne GLW			222 t FORCE ABOVE 30 tonne GLW				

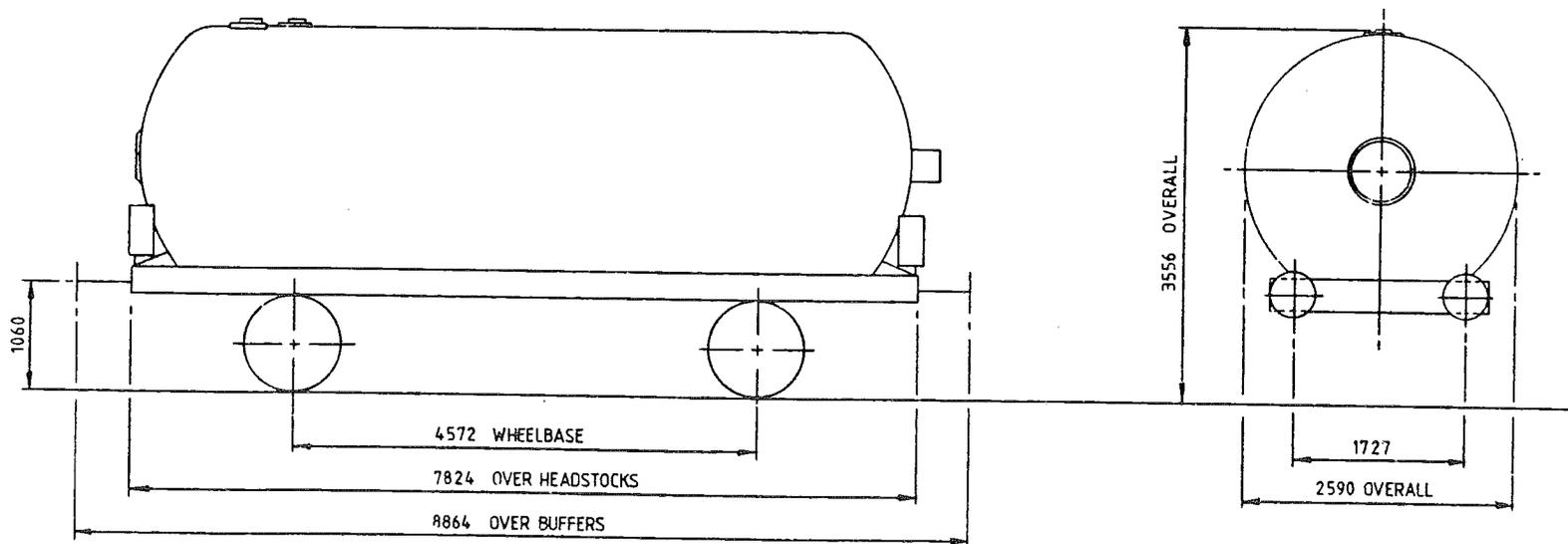

TARE-	21,400 Kg
CAPACITY, WEIGHT-	21,100 Kg
CAPACITY, VOLUME-	
MIN. CURVE-	31 m
GEN. ARRGT. DRG. NO.-	

BRAKE-	AIR BLOCK & HAND LEVER
SUSPENSION-	SINGLE LINK & PARABOLIC SPRING
COUPLINGS-	INSTANTER
BUFFERS-	HYDRAULIC 406 DIA. HEADS
WHEELS-	952 DIA.
JOURNALS-	140 DIA. ROLLER BEARINGS

ISSUE 1

42.5 tonne GLW TANK WAGON-LPG

LOT NUMBER	

TOPS INFORMATION						
AARKND	OPERATING	OPERATING SPEED		BRAKE FORCE DATA		EXCESS LENGTH
CARKND	PANEL No.	60 mile/h UP TO		9.29 t FORCE UP TO		RA
T T A A		mile/h ABOVE		22.21 t FORCE ABOVE		DESIGN SHEET
		42.5 tonne GLW		30 tonne GLW		WI551
				4	7	

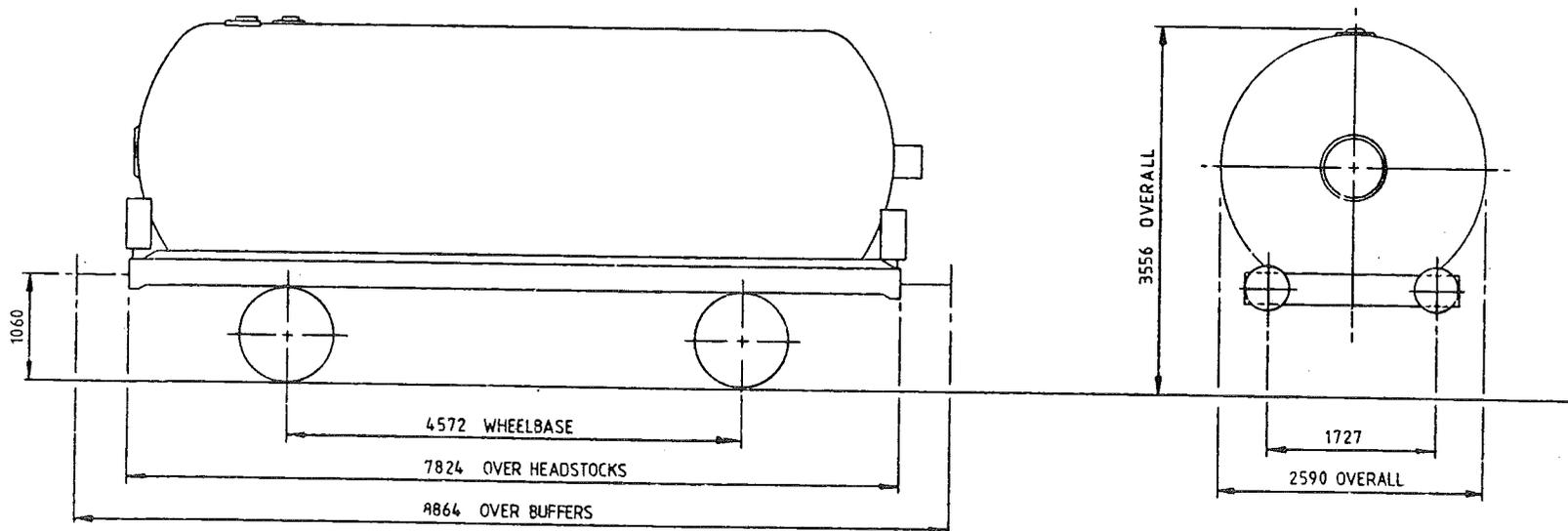

TARE-	21.850 Kg
CAPACITY, WEIGHT-	20.650 Kg
CAPACITY, VOLUME-	
MIN. CURVE-	31 m
GEN. ARRGT. DRG. NO.-	

BRAKE-	AIR BLOCK & HAND LEVER
SUSPENSION-	DOUBLE LINK & PARABOLIC SPRING
COUPLINGS-	INSTANTER
BUFFERS-	HYDRAULIC 406 DIA. HEADS
WHEELS-	952 DIA.
JOURNALS-	140 DIA. ROLLER BEARINGS

ISSUE 1

42.5 tonne GLW TANK WAGON - L.P.G.

LOT NUMBER	

TOPS INFORMATION						
AARKND	OPERATING PANEL No.		OPERATING SPEED		BRAKE FORCE DATA	
CARKND			60 mile/h UP TO 42.5 tonne GLW		9.29t FORCE UP TO 30 tonne GLW	
T T A A			mile/h ABOVE		22.21t FORCE ABOVE	
					EXCESS LENGTH	RA (GLW)
					4	7
					DESIGN SHEET W1552	

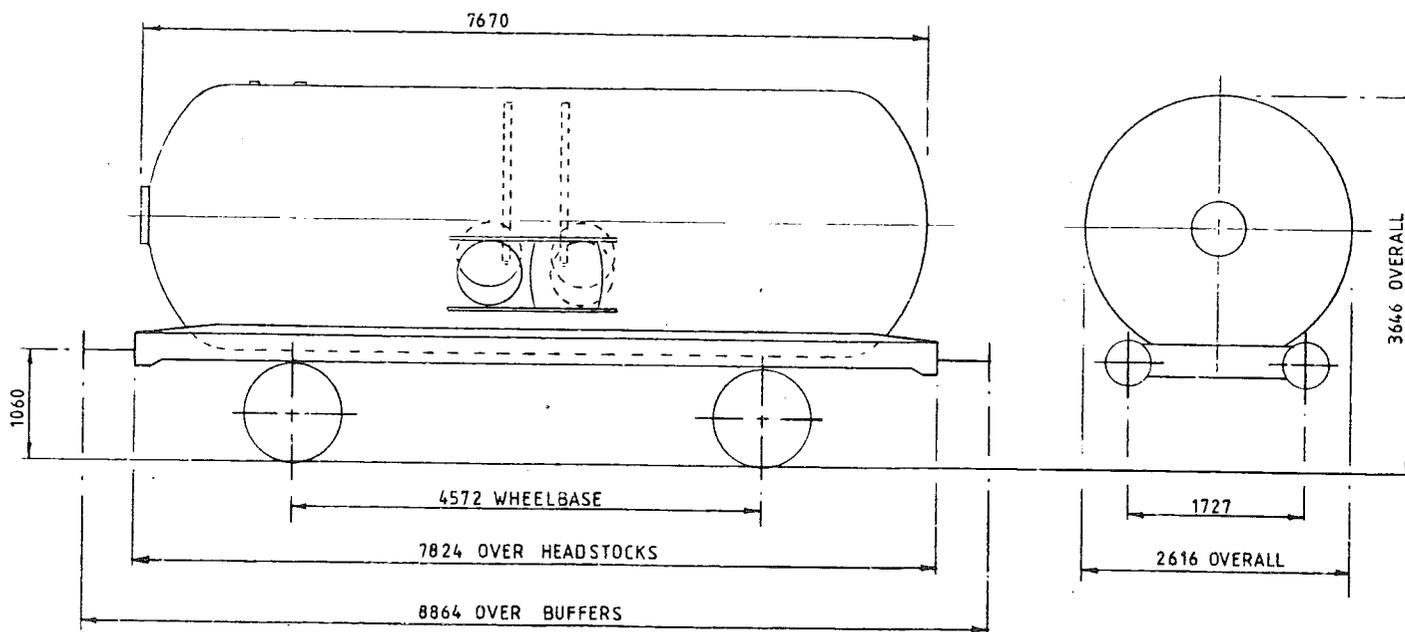

TARE-	22.050 Kg
CAPACITY, WEIGHT-	20.450 Kg
CAPACITY, VOLUME-	
MIN. CURVE-	31m
GEN. ARRGT. DRG. NO.-	

BRAKE-	AIR BLOCK & HAND LEVER
SUSPENSION-	DOUBLE LINK & PARABOLIC SPRING
COUPLINGS-	INSTANTER
BUFFERS-	HYDRAULIC 406 DIA HEADS
WHEELS-	952 DIA
JOURNALS-	140 DIA ROLLER BEARINGS

ISSUE 1

42.5 tonne GLW TANK WAGON - L.P.G.

LOT NUMBER	

TOPS INFORMATION											
AARKND	OPERATING		OPERATING SPEED			BRAKE FORCE DATA			EXCESS LENGTH	RA (GLW)	DESIGN SHEET
CARKND	PANEL No.		60 mile/h UP TO 42.5 tonne GLW			9t FORCE UP TO 30 tonne GLW			4	7	WI553
T	T	A	A								

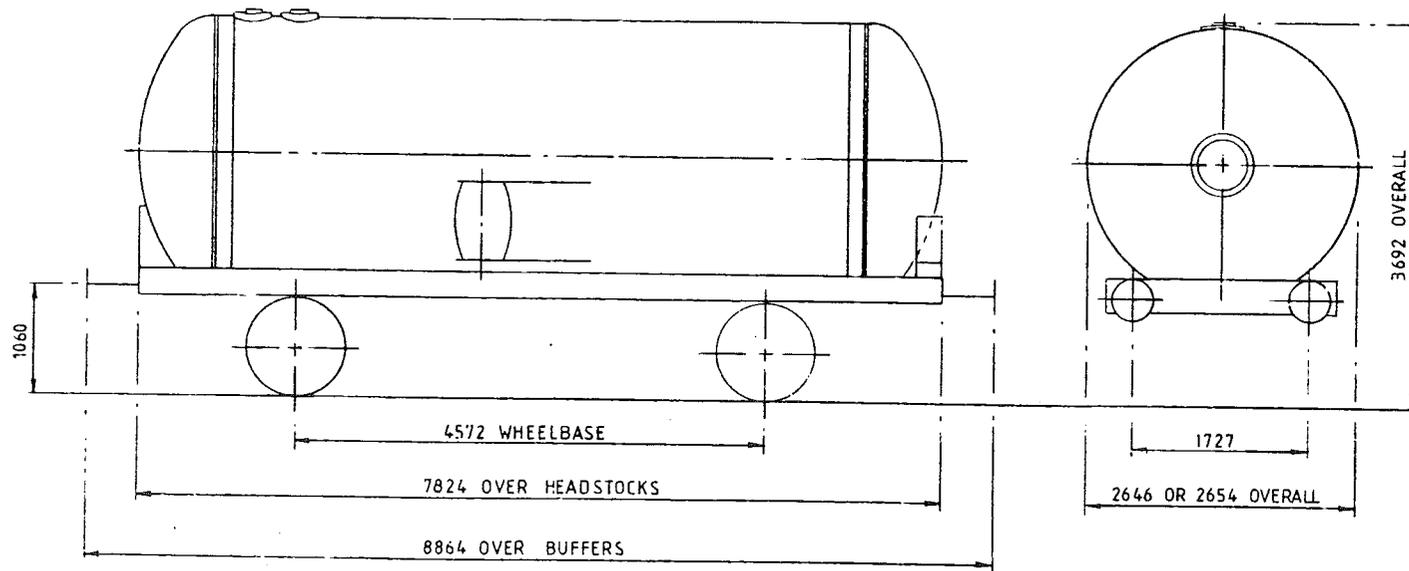

TARE-	18,080 Kg
CAPACITY, WEIGHT-	24,420 Kg
CAPACITY, VOLUME-	
MIN. CURVE-	31m
GEN. ARRGT. DRG. NO.-	

BRAKE-	AIR BLOCK & HAND LEVER
SUSPENSION-	SINGLE LINK & PARABOLIC SPRING
COUPLINGS-	INSTANTER
BUFFERS-	HYDRAULIC 406 DIA HEADS
WHEELS-	952 DIA
JOURNALS-	140 DIA ROLLER BEARINGS

ISSUE 1

42.5 tonne GLW TANK WAGON—LPG

LOT NUMBER	

TOPS INFORMATION								
AARKND	OPERATING	OPERATING SPEED		BRAKE FORCE DATA		EXCESS LENGTH	RA (GLW)	DESIGN SHEET
CARKND	PANEL No.	60 mile/h UP TO	42.5 tonne GLW	9 t	FORCE UP TO	30 tonne GLW	4	WI554
T T A A		60 mile/h ABOVE		22 t	FORCE ABOVE			

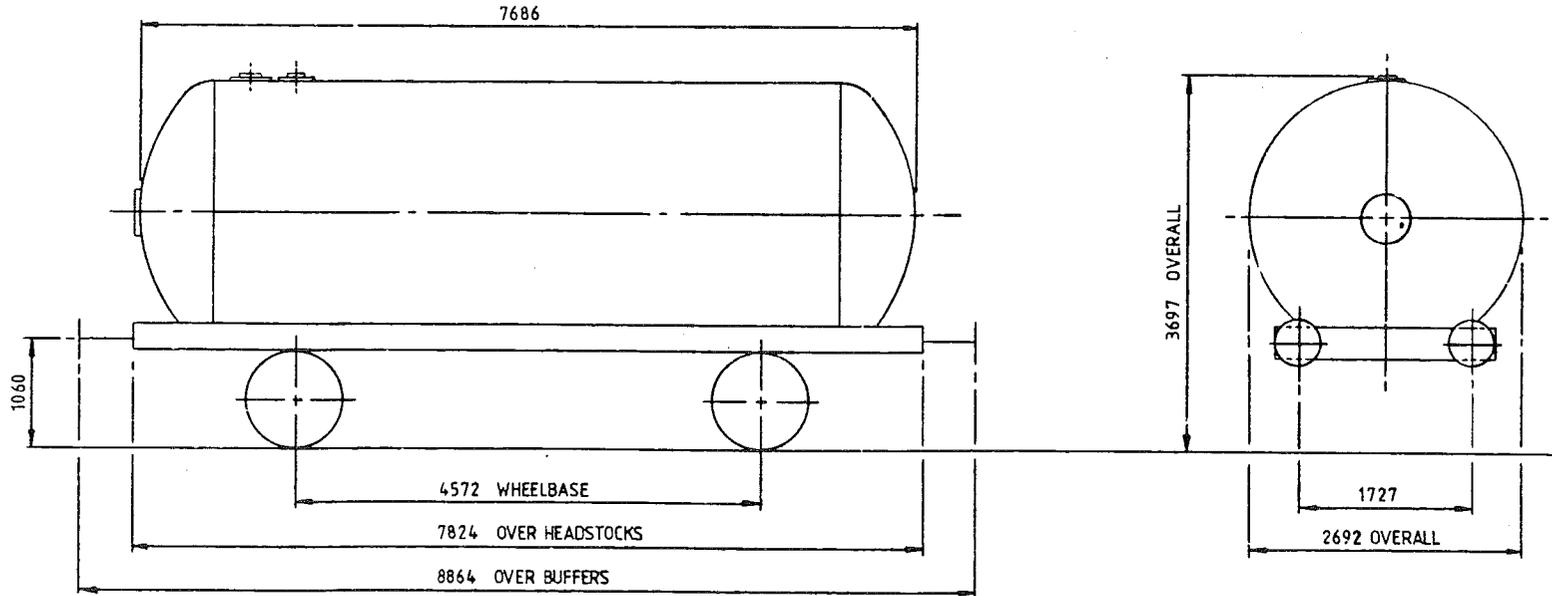

TARE-	21,800 Kg
CAPACITY, WEIGHT-	20,700 Kg
CAPACITY, VOLUME-	38,641 litres
MIN. CURVE-	31 m
GEN. ARRGT. DRG. NO.-	

BRAKE-	AIR BLOCK & HAND LEVER
SUSPENSION-	SINGLE LINK & PARABOLIC SPRING
COUPLINGS-	INSTANTER
BUFFERS-	HYDRAULIC 406 DIA. HEADS
WHEELS-	952 DIA.
JOURNALS-	140 DIA. ROLLER BEARINGS

ISSUE 1

46 tonne GLW TANK WAGON CLASS 'A'

LOT NUMBER	

TOPS INFORMATION										
AARKND		OPERATING		OPERATING SPEED		BRAKE FORCE DATA		EXCESS LENGTH	RA (GLW)	DESIGN SHEET
CARKND		PANEL No.		60 mile/h UP TO mile/h ABOVE		10t FORCE UP TO 22t FORCE ABOVE				
T	T	A	A			46 tonne GLW	31 tonne GLW	4	8	W1606

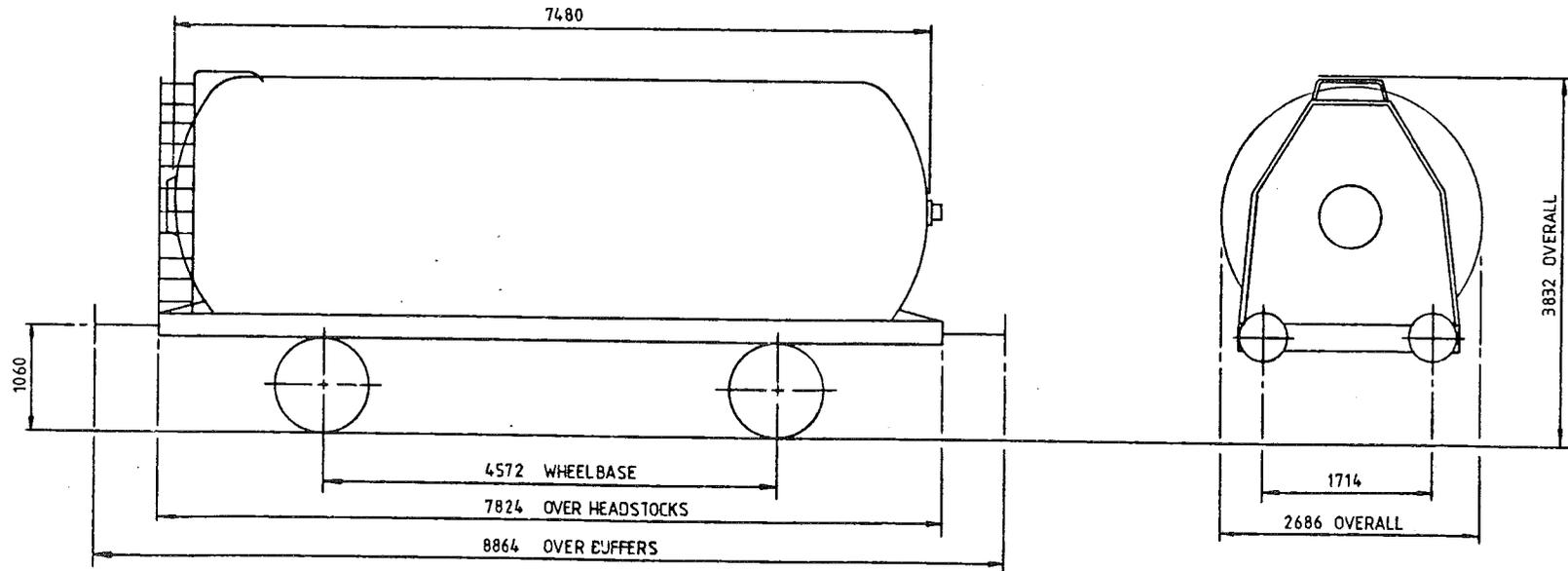

TARE-	13.000 Kg
CAPACITY, WEIGHT-	33.000 Kg
CAPACITY, VOLUME-	38.700 litres
MIN. CURVE-	31m
GEN. ARRGT. DRG. NO.-	

BRAKE-	AIR BLOCK, HAND LEVER
SUSPENSION-	DOUBLE LINK & PARABOLIC SPRING
COUPLINGS-	INSTANTER
BUFFERS-	HYDRAULIC 406 DIA. HEADS
WHEELS-	952 DIA.
JOURNALS-	140 DIA. ROLLER BEARINGS

ISSUE 1

51 tonnes G.L.W. TANK WAGON CLASS A.

TUOOIA

EXCESS LENGTH	7	H	M	L	E
tonnes	51	51	14	14	
VB					
AB	25	25	8	8	
RA	10	8	1	1	
MAX. SPEED	60	60	60	60	

TOPS CODE									
CARKND			AARKND			OPERATING PANEL No			
T	U	A	T	U	A	C	I	I	2

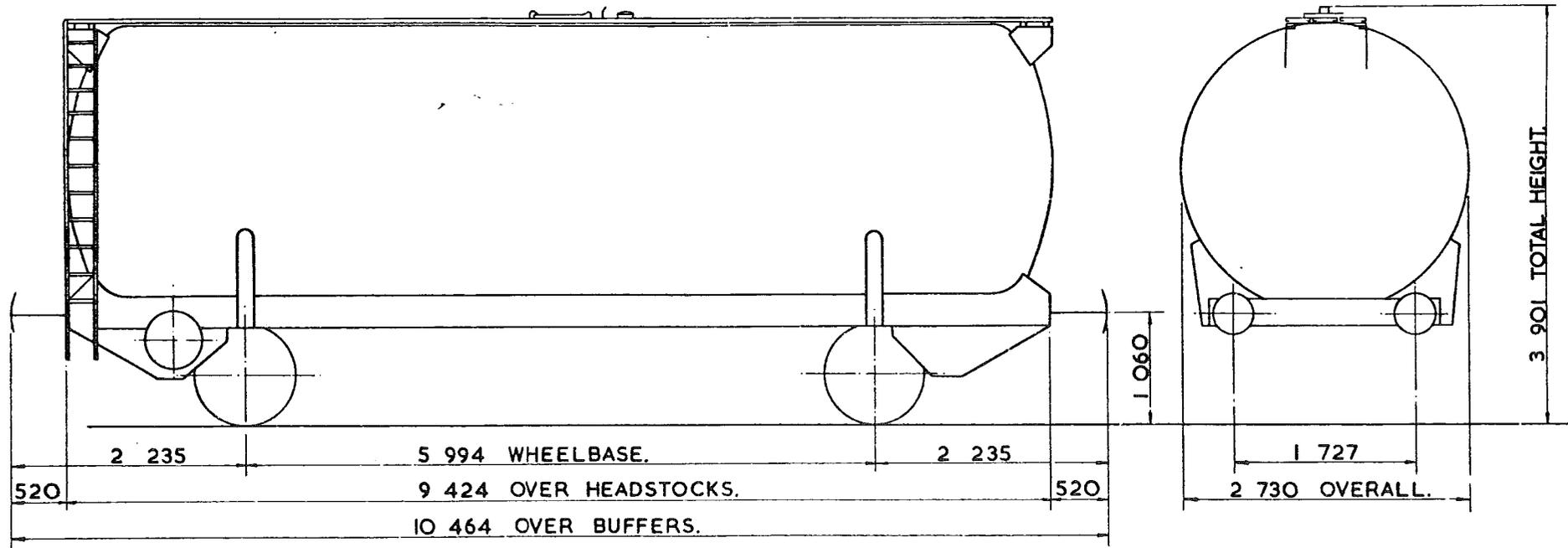

TARE - 13 700kg.
CARRYING CAPACITY - 37 300kg.
CUBIC CAPACITY - 52 733 litres.
MAX. SPEED - 60 mile/h.
WHEELS - 952 DIA.
JOURNALS - 150 DIA. ROLLER BEARINGS.

BUFFERS - HYDRAULIC 406 DIA. HEADS.
COUPLINGS - INSTANTER.
MIN. CURVE - 71m.
GEN. ARRGT. DRG. No. -
BRAKE - AIR DISC. & HAND SCREW
SUSPENSION - GLOUCESTER PRIMARY 2 AXLE.

BUILDER - CHARLES ROBERTS.
OWNER - PROCOR (U.K.) LTD.
REGISTERED BY - C.M. & E.E. (B.R.B.) DERBY.
YEAR BUILT - 1972.
REGISTRATION Nos. - 70023 TO 70067.
OWNERS Nos. - 70023 TO 70067.

ISSUE 2
EX.P.O. DIAGRAM 6/240 (ALLOCATED)

51 tonnes G.L.W. TANK WAGON CLASS B

TU00IB

EXCESS LENGTH	4	H	M	L	E
tonnes	51	51	14	14	
VB					
AB	25	25	8	8	
RA	10	8	1	1	
MAX. SPEED	60	60	60	60	

TOPS CODE										
CARKND		AARKND			OPERATING PANEL No					
T	U	A	T	U	A	C	1	1	2	2

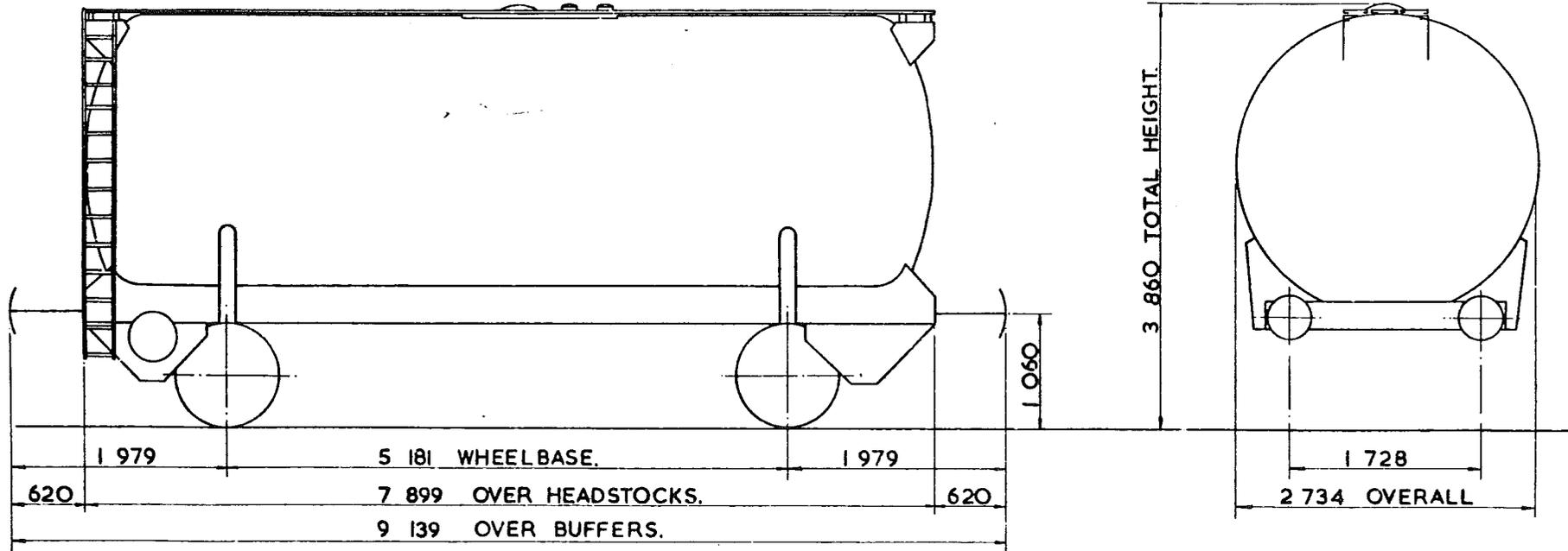

TARE - 13900kg.
CARRYING CAPACITY - 37100kg.
CAPACITY - 42141 litres
MAX. SPEED - 60 mile/h
WHEELS - 952 DIA.
JOURNALS - 150 DIA. ROLLER BEARINGS.

BUFFERS - HYDRAULIC 406 DIA. HEADS.
COUPLINGS - INTERNATIONAL SCREW.
MIN. CURVE - 31m.
GEN. ARRGT. DRG. No. -
BRAKE - AIR DISC & HAND SCREW
SUSPENSION - GLOUCESTER PRIMARY 2 AXLE.

BUILDER - STANDARD RAILWAY WAGON CO.
OWNER - PROCOR (UK) LTD.
REGISTERED BY - C.M. & E.E. (B.R.B.) DERBY.
YEAR BUILT - 1974
REGISTRATION Nos. - 70068 TO 70092.
OWNERS Nos. - 70068 TO 70092.

ISSUE 2
EX BO DIAGRAM

51 tonnes G.L.W. TANK WAGON CLASS B

TU00IC

EXCESS LENGTH	5	H	M	L	E
tonnes	51	51	15	15	
VB					
AB	25	25	10	10	
PA	10	8	1	1	
MAX SPEED	60	60	60	60	

TOPS CODE										
CARKND			AARKND			OPERATING PANEL No				
T	U	A	T	U	A	C	I	I	2	9

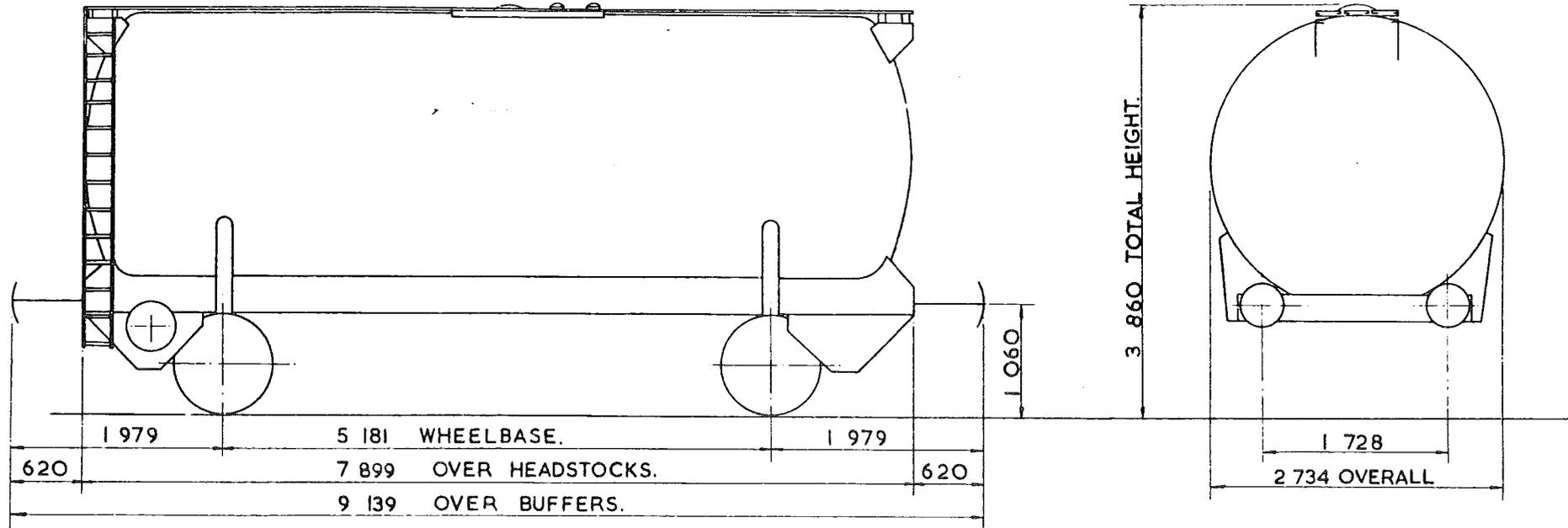

TARE - 15050kg.
CARRYING CAPACITY - 35900kg.
CAPACITY - 42141 litres.
MAX SPEED - 60 mile/h.
WHEELS - 952 DIA.
JOURNALS - 150 DIA. ROLLER BEARINGS.

BUFFERS - HYDRAULIC 406 DIA. HEADS
COUPLINGS - INTERNATIONAL SCREW.
MIN CURVE - 31m.
GEN. ARRG. DRG No -
BRAKE - AIR DISC & HAND SCREW
SUSPENSION - SCHLIEREN PRIMARY 2 AXLE.

BUILDER - NORBRIT PICKERING.
OWNER - PROCOR (UK) LTD.
REGISTERED BY - C.M. & E.E. (B.R.B) DERBY.
YEAR BUILT - 1974
REGISTRATION Nos - 70093
OWNERS Nos - 70093

ISSUE 2
EX. P.O. DIAGRAM 6/651 (ALLOCATED)

51 tonnes G.L.W. TANK WAGON CLASS A.

TUO0ID

EXCESS LENGTH	5	H	M	L	E
tonnes	51	51	14	14	
VB					
AB	24	24	8	8	
RA	10	8	1	1	
MAX SPEED	60	60	60	60	

TOPS CODE		
CARKND	AARKND	OPERATING PANEL No
TUA	TUAC	11144

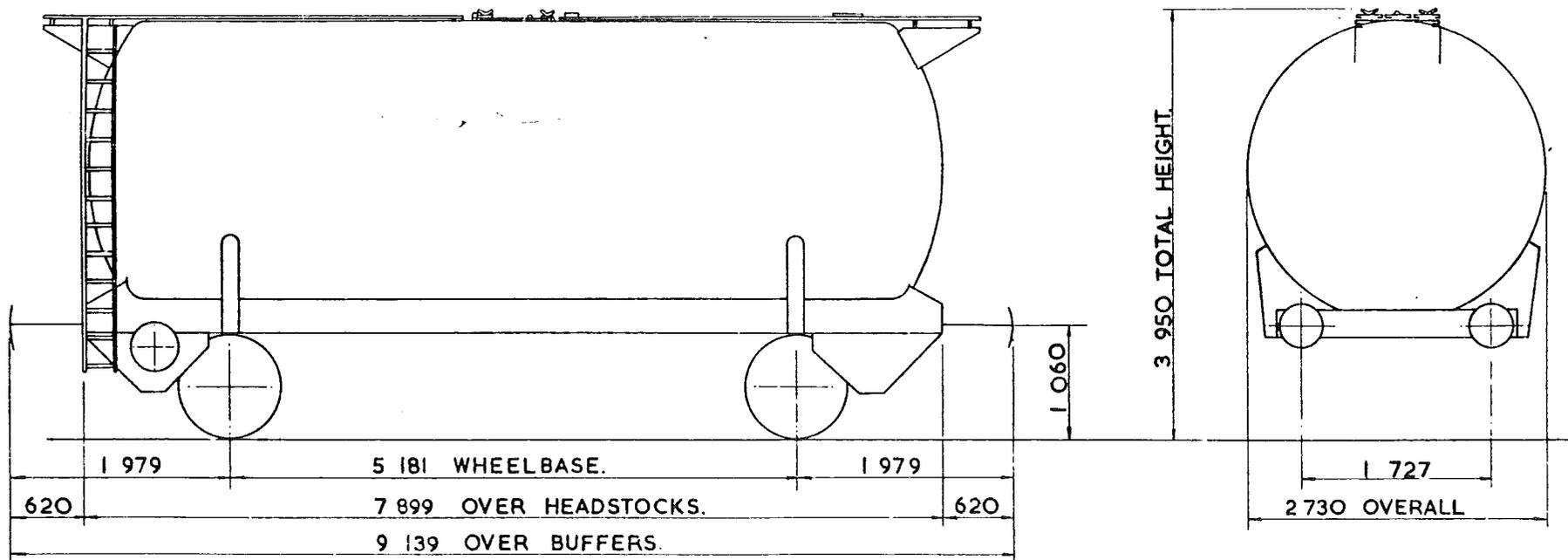

TARE - 13800kg.
CARRYING CAPACITY - 37200kg.
CAPACITY - 43870 litres.
MAX. SPEED - 60 mile/h.
WHEELS - 952 DIA.
JOURNALS - 150 DIA. ROLLER BEARINGS.

BUFFERS - HYDRAULIC 406 DIA. HEADS.
COUPLINGS - INTERNATIONAL SCREW.
MIN. CURVE - 31m.
GEN. ARRGT. DRG No. -
BRAKE - AIR DISC, & HAND SCREW
SUSPENSION - GLOUCESTER PEDESTAL.

BUILDER - NORBRIT PICKERING.
OWNER - PROCOR (U.K.) LTD.
REGISTERED BY - C.M. & E.E.(B.R.B.) DERBY.
YEAR BUILT - 1973.
REGISTRATION Nos. - 70098 TO 70117
OWNERS Nos. - 70098 TO 70117

ISSUE 2
EX. P.O. DIAGRAM 6/800 (ALLOCATED)

51 tonnes G.L.W. TANK WAGON CLASS B

TU001E

EXCESS LENGTH	5	H	M	L	E
tonnes	51	51	15	15	
VB					
AB	25	25	10	10	
RA	10	8	1	1	
MAX SPEED	60	60	60	60	

TOPS CODE										
CARKND	AARKND			OPERATING PANEL No						
T	U	A	T	U	A	C	I	I	2	9

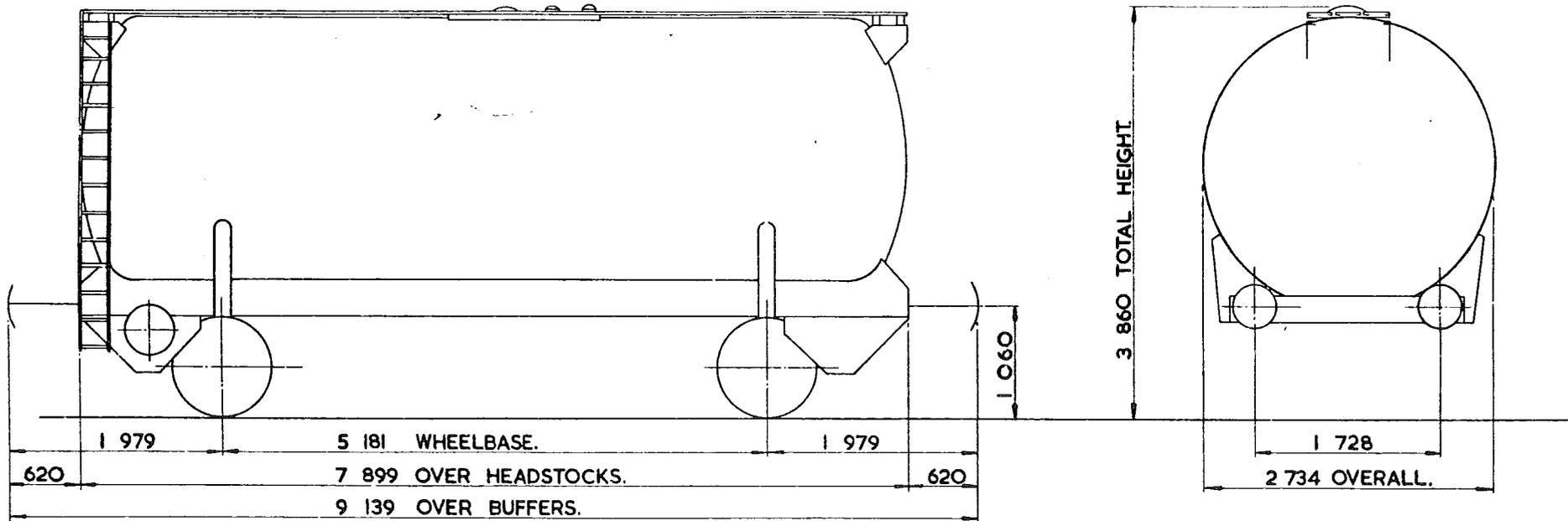

TARE -	14750kg.
CARRYING CAPACITY -	36 200kg.
CAPACITY -	42141 litres.
MAX. SPEED -	60 mile/h.
WHEELS -	952 DIA.
JOURNALS -	150 DIA. ROLLER BEARINGS.

BUFFERS -	HYDRAULIC 406 DIA. HEADS.
COUPLINGS -	INTERNATIONAL SCREW.
MIN. CURVE -	31 m.
GEN. ARRGT. DRG No. -	
BRAKE -	AIR DISC & HAND SCREW.
SUSPENSION -	GLOUCESTER PEDESTAL.

BUILDER -	NORBRIT PICKERING.
OWNER -	PROCOR (U.K.) LTD.
REGISTERED BY -	C.M. & E.E. (B.R.B.) DERBY.
YEAR BUILT -	1974
REGISTRATION Nos. -	70094 TO 70097.
OWNERS Nos. -	70094 TO 70097.

ISSUE 2
EX. P.O. DIAGRAM 6/651 (ALLOCATED)

51 tonnes G. L.W. TANK WAGON - PHOSPHORIC ACID.

TU 002 A

EXCESS LENGTH 4	H	M	L	E
tonnes	51	51	13	13
VB	0	0	0	0
AB	25	25	11	11
RA	10	8	1	1
MAX SPEED	60	60	60	60

TOPS CODE		
CARKND	AARKND	OPERATING
T	U	B
T	U	B
C	I	0
9	7	

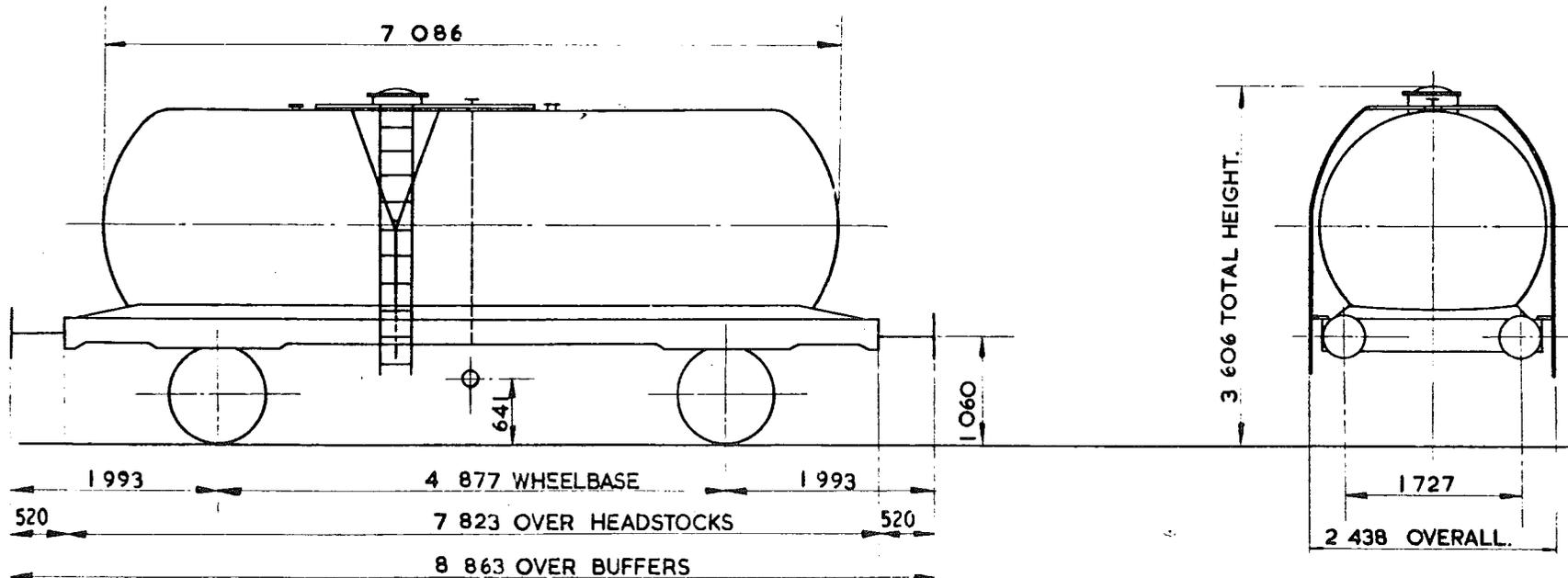

	13 200 kg.
CARRYING CAPACITY	37 800 kg.
CAPACITY	24 584 litres.
MAX SPEED	60 mile/h.
WHEEL DIA.	952 DIA.
WHEEL BEARINGS	140 DIA. ROLLER BEARINGS.

BUFFERS	HYDRAULIC 406 DIA. HEADS
COUPLINGS	INSTANTER.
MIN. CURVE	31m.
GEN. ARRGT DRG. No	
BRAKE	AIR BLOCK, VACUUM PIPED & HAND LEVER.
SUSPENSION	PEDESTAL.

BUILDER	STANDARD RAILWAY WAGON Co.
OWNER	PROCOR (U.K.) LTD.
REGISTERED BY	C.M. & E.E. (B.R. B.) DERBY.
YEAR BUILT	1972.
REGISTRATION Nos.	70001 TO 70022.
OWNERS Nos.	MD.1. TO MD. 22.

ISSUE 2
EX. P.O. DIAGRAM 6/254.

51 tonnes G.L.W. TANK WAGON - CLASS B

TU003A

EXCESS LENGTH	4	H	M	L	E
tonnes	51	51	14	14	
VB					
AB	31	31	9	9	
RA	10	8	1	1	
MAX. SPEED	60	60	60	60	

TOPS CODE		
CARKND	AARKND	UNITARY
T	U	A
U	A	C
I	O	9
0		

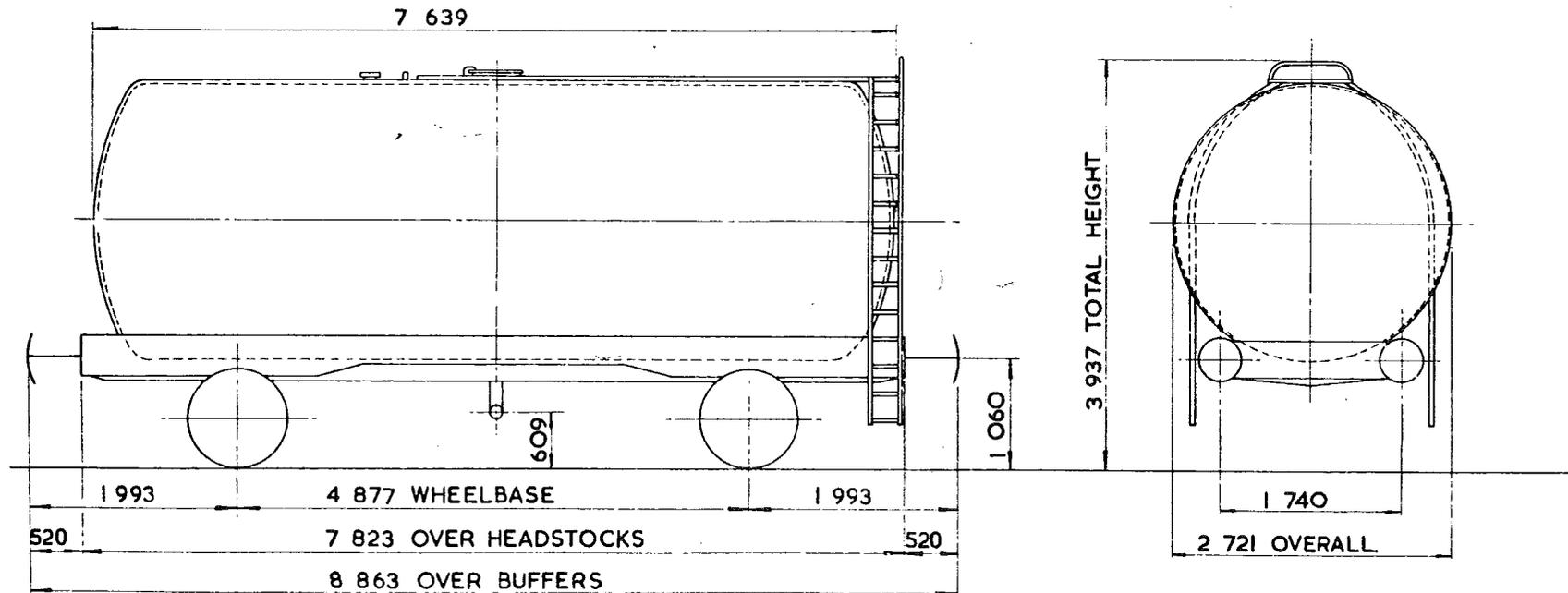

TARE - 13 700 kg.
CARRYING CAPACITY - 37 300 kg.
CAPACITY - 39 768 litres.
MAX SPEED - 60 mile/h.
WHEELS - 952 DIA.
JOURNALS - 150 DIA. ROLLER BEARINGS

BUFFERS - HYDRAULIC 406 DIA. HEADS
COUPLINGS - INSTANTER
MIN CURVE - 31m.
GEN. ARRGT DRG. No.
BRAKE - AIR DISC & HAND LEVER.
SUSPENSION - FRICTION PEDESTAL

BUILDER - CHARLES ROBERTS
OWNER - SUKO
REGISTERED BY - C.M. & E.E. (B.R.B.) DERBY.
YEAR BUILT - 1972-3.
REGISTRATION Nos. - SUKO 73000
OWNERS Nos. -

ISSUE 2
EX PO. DIAGRAM 6/255

51 tonnes GLW TANK WAGON-CLASS B-LAGGED & COILED

TU004A

EXCESS LENGTH	5	H	M	L	E
tonnes	51	51	14	14	
VB					
AB	25	25	8	8	
RA	10	8	1	1	
MAX SPEED	60	60	60	60	

TOPS CODE		
CARND	AARKND	OPERATING PANEL
T	U A T U A C I I	2 8

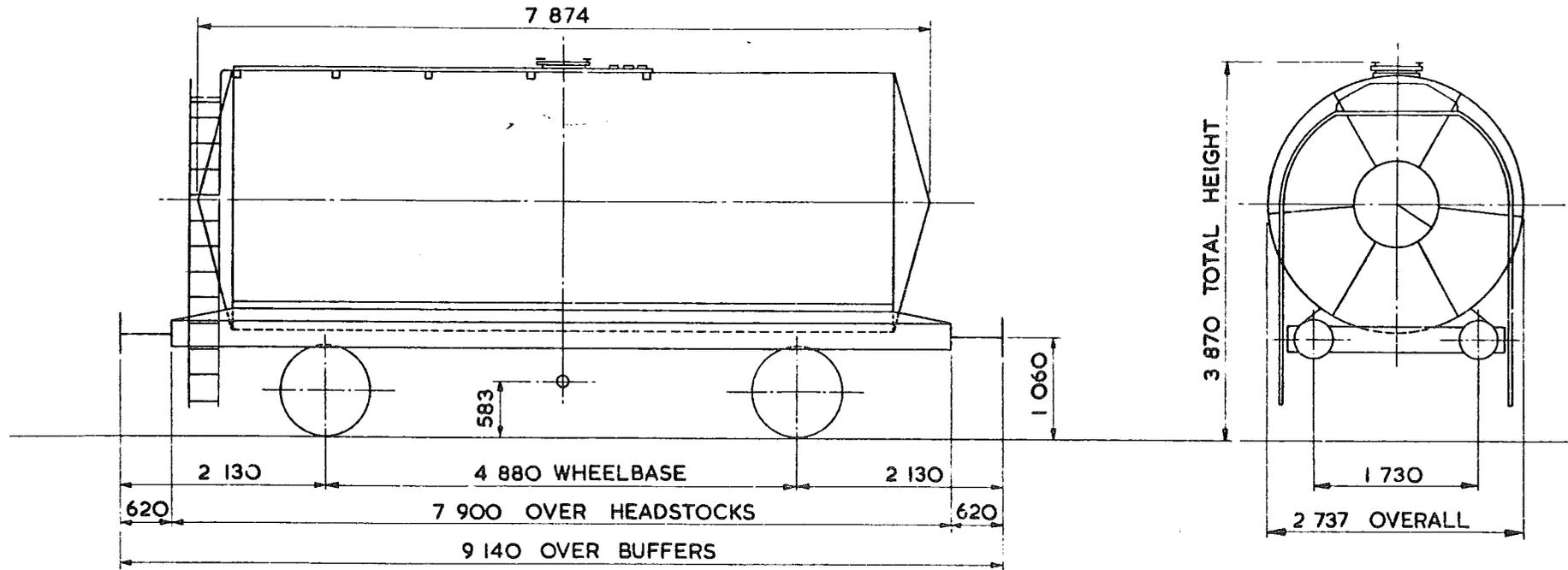

TARE - 14 200 kg
CARRYING CAPACITY - 36 800 kg
CAPACITY - 40 346 litres
MAX. SPEED - 60 mile/h
WHEELS - 952 DIA.
JOURNALS - 150 DIA. ROLLER BEARINGS

BUFFERS - HYDRAULIC 406 DIA. HEADS
COUPLINGS - INTERNATIONAL SCREW
MIN. CURVE - 41 m.
GEN. ARRGT. DRG. No. -
BRAKE - AIR DISC & HAND LEVER.
SUSPENSION - PRIMARY FLOATING AXLE

BUILDER - STANDARD RAILWAY WAGON CO.
OWNER - BRITISH RAILWAY TRAFFIC & ELECTRIC
REGISTERED BY - C.M. & E.E. (B.R.B.) DERBY
YEAR BUILT - 1973
REGISTRATION Nos. - 70500 TO 70523 INCL.
OWNERS Nos. - 70500 TO 70523 INCL.

ISSUE 2

EX. P.O. DIAGRAM 6/252 (ALLOCATED)

51 tonnes G.L.W. TANK WAGON - CLASS B

TU005A

EXCESS LENGTH	5	H	M	L	E
tonnes	51	51	14	14	
VB	0	0	0	0	
AB	25	25	8	8	
RA	10	8	1	1	
MAX SPEED	60	60	60	60	

TOPS CODE		
CARKND	AARKND	OPERATING PANEL No.
T	U	B
T	U	B
C	I	I
4	9	

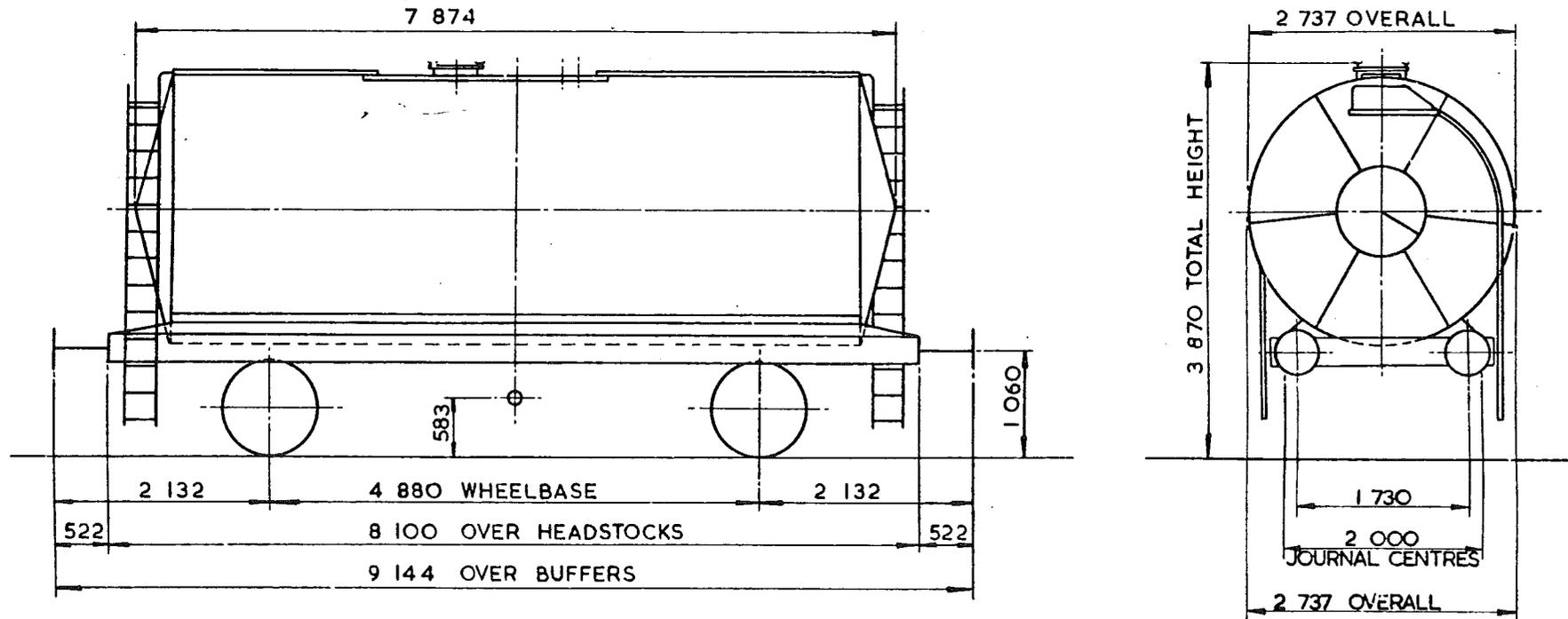

TARE - 13 950 kg
CARRYING CAPACITY - 37 000 kg
CAPACITY - 40 345 litres
MAX. SPEED - 60 mile/h
WHEELS - 952 DIA.
JOURNALS - 150 DIA. ROLLER BEARINGS

BUFFERS - HYDRAULIC 406 DIA. HEADS
COUPLINGS - INSTANTER
MIN. CURVE 41m
GEN ARRGT DRG. No. -
BRAKE - AIR DISC, VACUUM PIPED & HAND LEVER
SUSPENSION - PRIMARY FLOATING AXLE

BUILDER - STANDARD RAILWAY WAGON Co.
OWNER - PETROFINA (UK) LTD.
REGISTERED BY - C.M. & E.E. (B.R.B.) DERBY
YEAR BUILT - 1973
REGISTRATION Nos. - 70900 TO 70931
OWNERS Nos. - 70900 TO 70931

ISSUE 2
EX P.O. DIAGRAM 6/819 (ALLOCATED)

51 tonnes TANK WAGON

TU005B

LOT NUMBER	

TOPS INFORMATION											
AARKND		OPERATING		OPERATING SPEED			BRAKE FORCE DATA		EXCESS LENGTH	RA (GLW)	DESIGN SHEET
CARKND	PANEL No.	60 mile/h UP TO 51 tonne GLW			8† FORCE UP TO 25† FORCE ABOVE 35† GLW		5	10	W 16 50		
T	U	A	C								

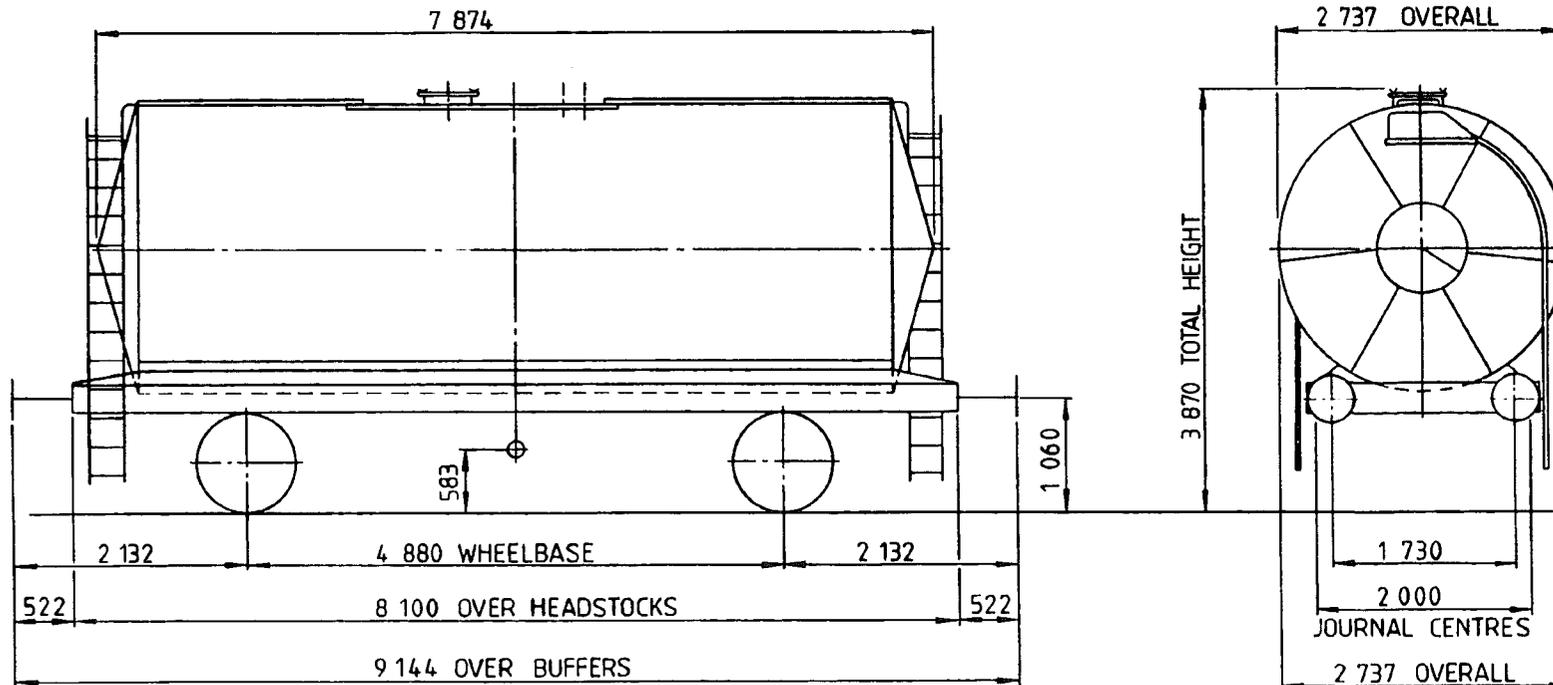

TARE-	13 950 kg
CAPACITY, WEIGHT-	37 050 kg
CAPACITY, VOLUME-	40 345 LITRES
MIN. CURVE-	41 m
GEN. ARRGT. DRG. NO.-	

BRAKE-	AIR DISC, & HAND LEVER
SUSPENSION-	PRIMARY FLOATING AXLE
COUPLINGS-	INSTANTER
BUFFERS-	HYDRAULIC 406 DIA. HEADS
WHEELS-	952 DIA.
JOURNALS-	150 DIA. ROLLER BEARINGS

ISSUE 1

EX. BR. DIAGRAM

51 tonnes G.L.W. TANK WAGON BITUMEN LAGGED & COILED

TU 006 A

EXCESS LENGTH	4	H	M	L	E
tonnes	51	51	16	16	
VB	0	0	0	0	
AB	32	32	10	10	
RA	10	8	1	1	
MAX SPEED	60	60	60	60	

TOPS CODE				
CARKND	AARKND	OPERATING PANEL No.		
T	U	B	T	U
B	C	I	I	5
				0

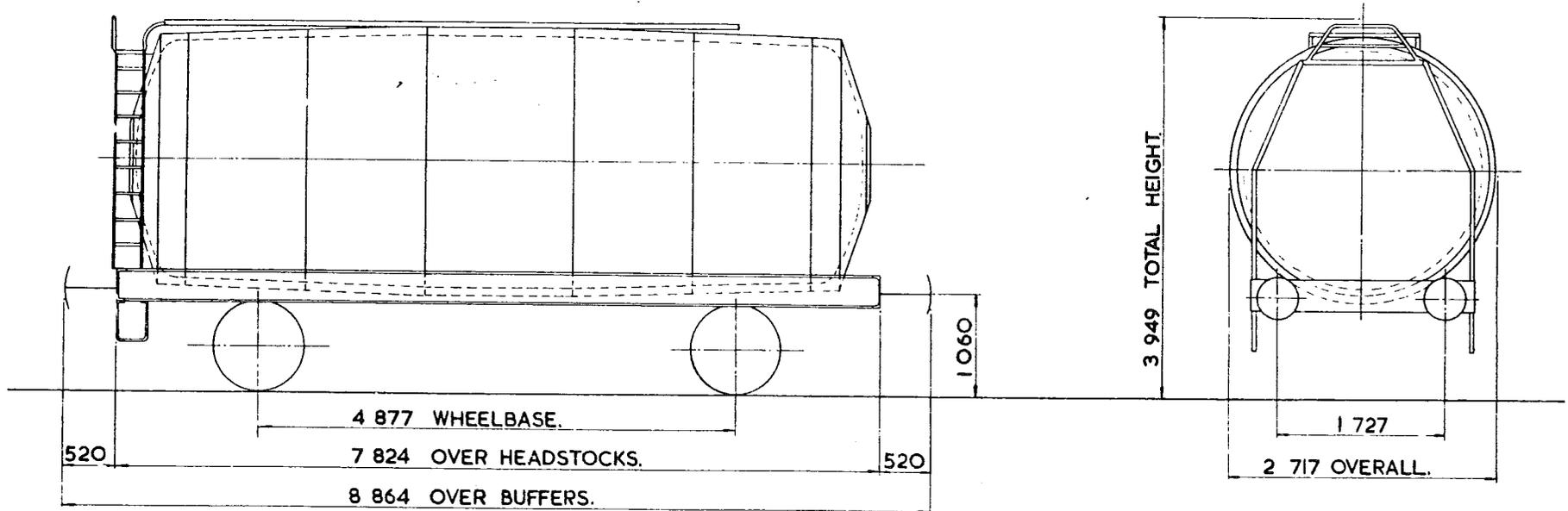

TARE 16 000 kg
CARRYING CAPACITY - 35 000 kg
CAPACITY - 34 167 litres
MAX. SPEED - 60 mile/h
WHEELS - 952 DIA.
JOURNALS - 150 DIA. ROLLER BEARINGS.

BUFFERS - HYDRAULIC 406 DIA. HEADS.
COUPLINGS - INSTANTER.
MIN CURVE - 31m.
GEN. ARRGT. DRG. No.
BRAKE - AIR BLOCK, VACUUM PIPE & HAND LEVER
SUSPENSION - FRICTION PEDESTAL.

BUILDER - CHARLES ROBERTS.
OWNER - SUKO.
REGISTERED BY - C.M. & E.E. (B.R.B) DERBY.
YEAR BUILT - 1973.
REGISTRATION Nos - 71500.
OWNERS Nos. -

ISSUE 2

EX. P.O. DIAGRAM 6/799 (ALLOCATED)

51 tonne GLW TANK WAGON BITUMEN LAGGED & COILED

LOT NUMBER	

TOPS INFORMATION						
AARKND	OPERATING	OPERATING SPEED		BRAKE FORCE DATA		EXCESS LENGTH
CARKND	PANEL No.	60 mile/h UP TO	51 tonne GLW	10t FORCE UP TO	41 tonne GLW	RA (GLW)
TUAC		mile/h ABOVE		32t FORCE ABOVE		4
						10
						W1247

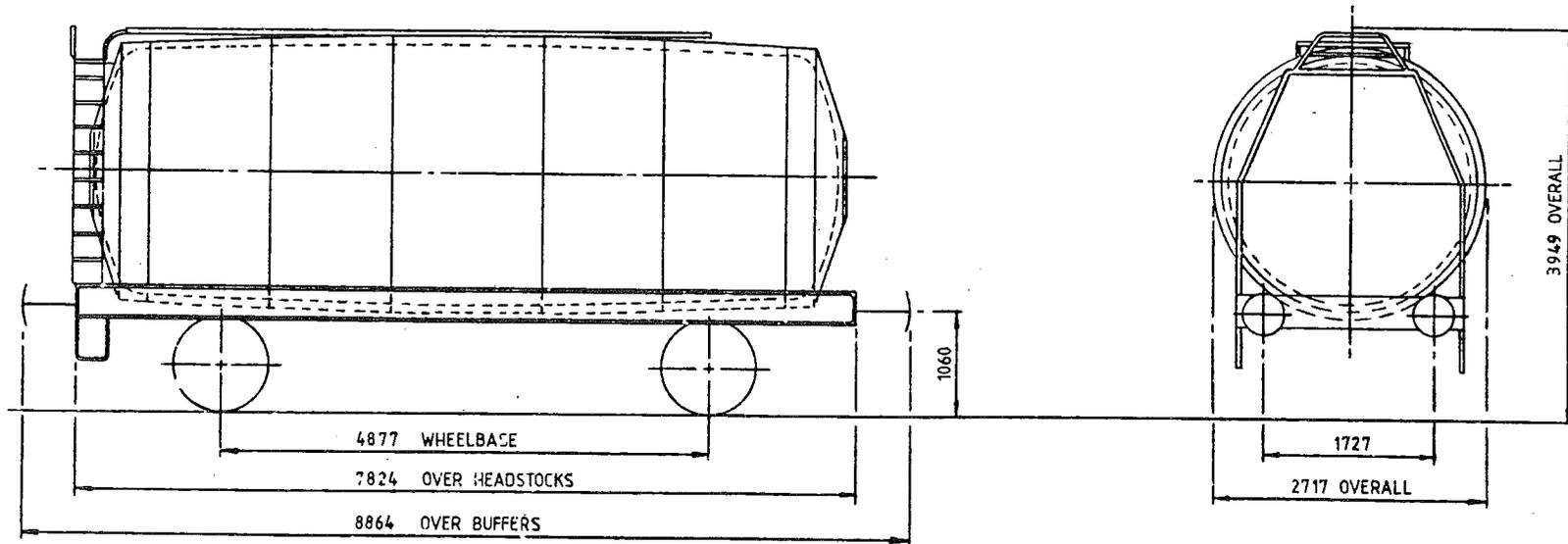

TARE-	16.000 Kg
CAPACITY, WEIGHT-	35000Kg
CAPACITY, VOLUME-	34.167 litres
MIN. CURVE-	31m
GEN. ARRGT. DRG. NO.-	

BRAKE-	AIR BLOCK & HAND LEVER
SUSPENSION-	FRICITION PEDESTAL
COUPLINGS-	INSTANTER
BUFFERS-	HYDRAULIC 406 DIA.HEADS
WHEELS-	952 DIA.
JOURNALS-	150 DIA. ROLLER BEARINGS

ISSUE 1

51 tonne G.L.W. CAUSTIC LIQUOR TANK WAGON

TU009A

EXCESS LENGTH	H	M	L	E
tonnes	51	51	14	14
VB				
AB	27	27	10	10
BA	10	6	1	1
MAX SPEED	60	60	60	60

TOPS CODE										
CARKND	AARKND	PARTS CODE								
T	U	A	T	U	A	C	1	1	8	7

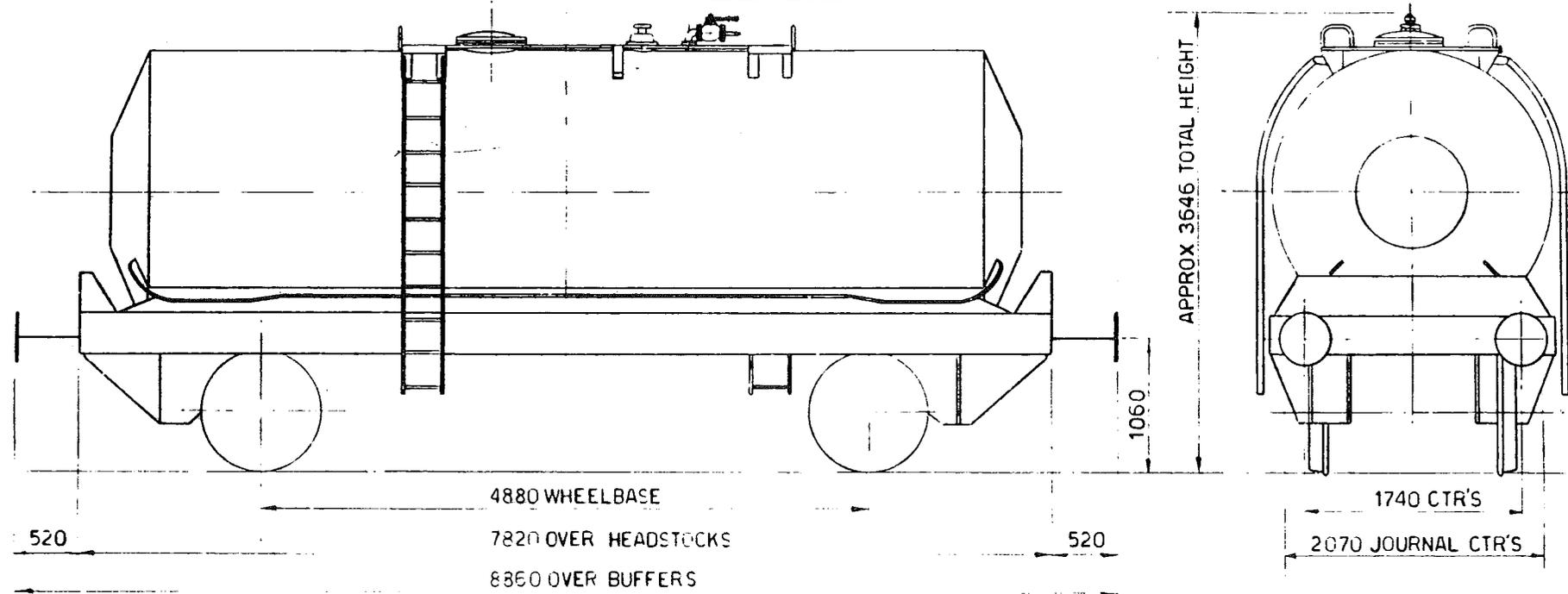

TARE 13450 kg
CARRYING CAPACITY - 37500 kg
CAPACITY - 25913 litres
MAX SPEED 60 mile/h
WHEELS 952 DIA
JOURNALS 150 ROLLER BEARING

BUFFERS HYDRAULIC 406 DIA HEADS
COUPLINGS INSTANTER
MIN CURVE 41m SINGLE and CLOSE COUPLED
GEN ARRGT DRG No 741012/01 (PROCOR(UK)LTD)
BRAKE AIR DISC and HAND LEVER
SUSPENSION B.S.C. PEDESTAL

ISSUE 1

EX PO DIAGRAM 6 / 246 (ALLOCATED)

51 tonnes G.L.W. CAUSTIC SODA LIQUOR TANK WAGON

TU010A

EXCESS LENGTH	H	M	L	E
tonnes	51	51	16	16
VB				
AB	26	26	8	8
R	10	6	1	1
MAX SPEED	60	60	60	60

TOPS CODE										
CARKND		AARKND		OPERATING PANEL						
T	U	A	T	U	A	C	1	2	1	3

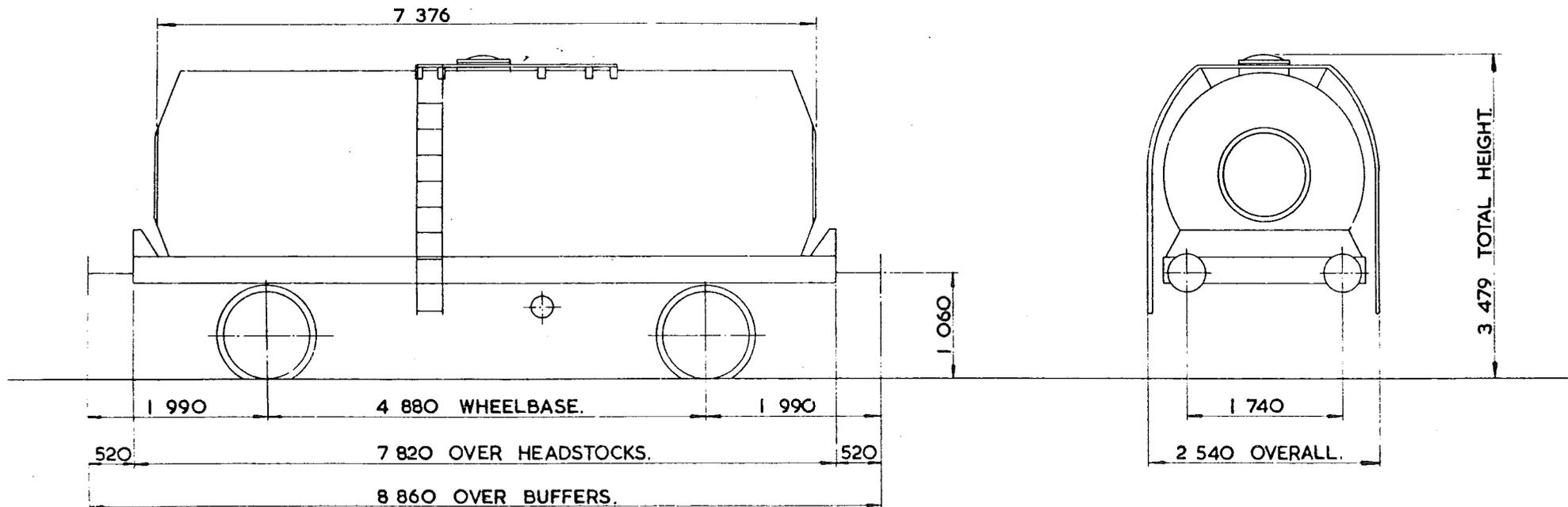

TARE	16 000kg.
CARRYING CAPACITY-	35 000kg.
CAPACITY-	25.912 litres.
MAX. SPEED -	60mile/h.
WHEELS -	952 DIA.
JOURNALS -	150 DIA. ROLLER BEARINGS.

BUFFERS -	HYDRAULIC 406 DIA. HEADS.
COUPLINGS -	INSTANTER.
MIN CURVE	51m.
GEN ARRGT DRG No	
BRAKE -	AIR BLOCK & HAND LEVER.
SUSPENSION -	PEDESTAL.

REGISTERED BY	PROCOR.
OWNER -	PROCOR.
REGISTERED BY	C.M. & E.E.(B.R.B.) DERBY.
YEAR BUILT -	1976.
REGISTRATION Nos -	PR.70138 - 70149.
OWNERS Nos -	

ISSUE 2

EX. P.O. DIAGRAM 6/251 (ALLOCATED.)

51 tonne GLW TANK WAGON CLASS 'A'

LOT NUMBER	

TOPS INFORMATION							
AARKND	OPERATING PANEL No.	OPERATING SPEED		BRAKE FORCE DATA	EXCESS LENGTH	RA (GLW)	DESIGN SHEET
CARKND		60 mile/h UP TO	51 tonne GLW	8t FORCE UP TO	4	10	W1242
T U A		mile/h ABOVE		25t FORCE ABOVE			
				35tonne GLW			

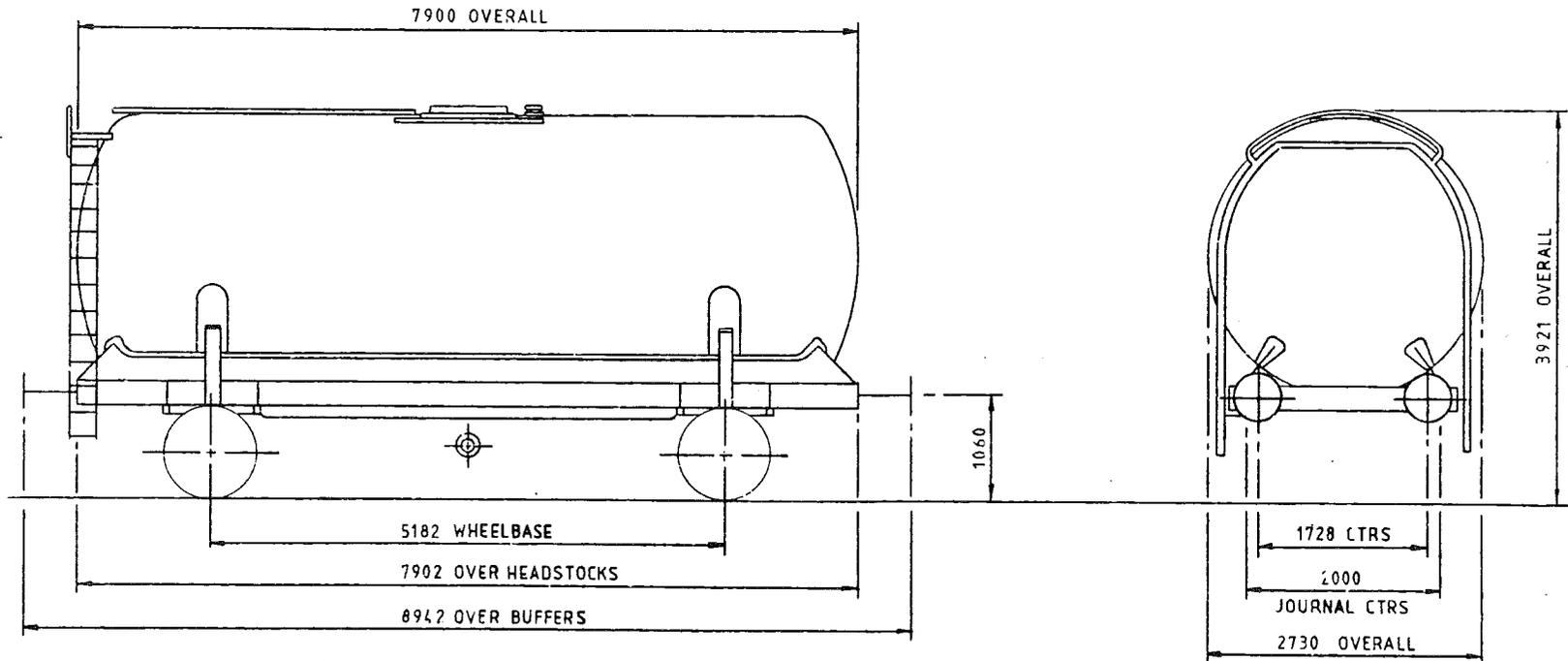

TARE-	14,750 Kg
CAPACITY, WEIGHT-	36,200 Kg
CAPACITY, VOLUME-	43,580 litres
MIN. CURVE-	43m SINGLY & CLOSE COUPLED
GEN. ARRGT. DRG. NO.-	

BRAKE-	AIR BLOCK & HAND LEVER
SUSPENSION-	B.S.C. PEDESTAL
COUPLINGS-	INSTANTER
BUFFERS-	HYDRAULIC 406 DIA. HEADS
WHEELS-	952 DIA.
JOURNALS-	150 DIA. ROLLER BEARINGS

ISSUE 1

51 tonne G.L.W. LAGGED & COILED CLASS B TANK WAGON TU016A

EXCESS LENGTH	4	H	M	L	E
tonnes	51	51	14	14	
VB	0	0	0	0	
AB	26	25	8	8	
RA	10	8	1	1	
MAX SPEED	60	60	60	60	

TOPS CODE										
CARKND		AARKND			OPERATING PANEL No					
T	U	B	T	U	B	C	1	3	5	3

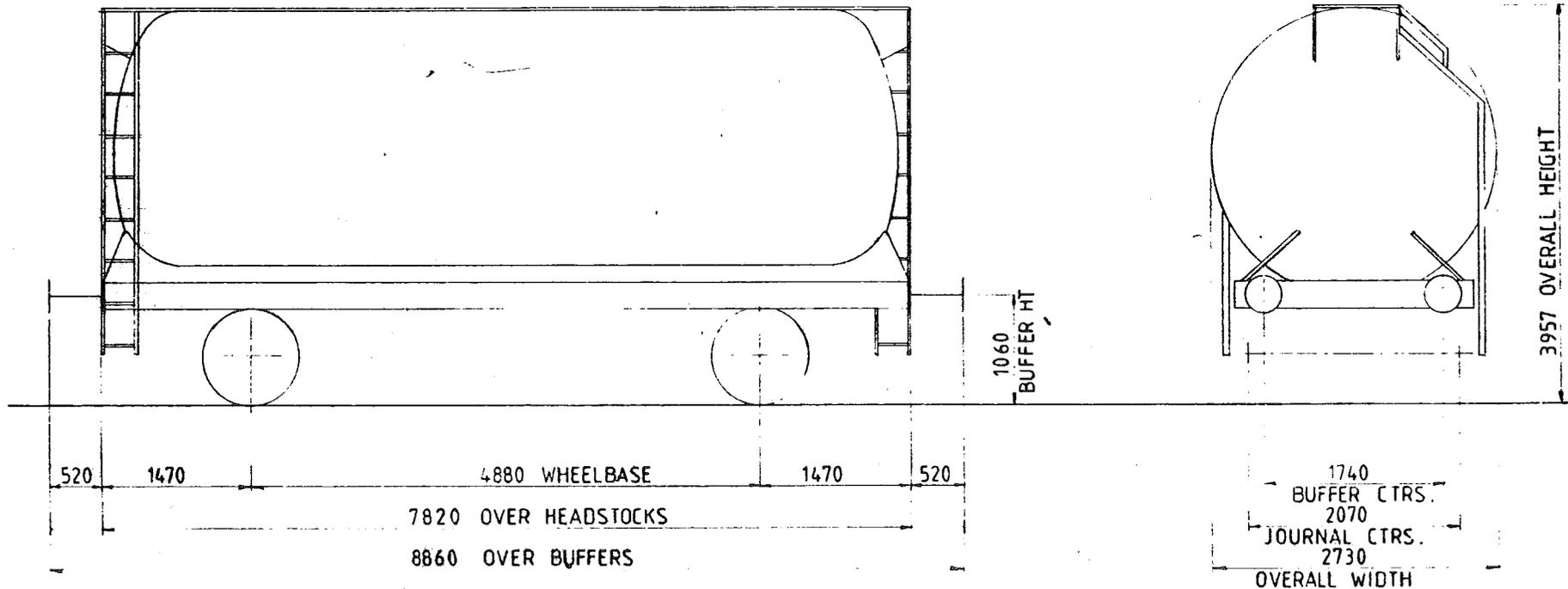

TARE -	14 ⁵⁰⁰ kg
CARRYING CAPACITY -	36 ⁵⁰⁰ kg
CAPACITY -	37 ⁸²³ litres
MAX. SPEED -	60 m/h.
WHEELS -	952 DIA
JOURNALS -	150 DIA ROLLER BEARINGS

BUFFERS	HYDRAULIC 460 DIA HEADS
COUPLINGS -	INSTANTER
MIN. CURVE -	35m SINGLY 38m CLOSE COUPLED
GEN. ARRGT DRG No. -	781214/01 (PROCOR LT [®])
BRAKE -	AIR BLOCK & VAC PIPE, HAND LEVER.
SUSPENSION -	GLOUCESTER FLOATING AXLE

ISSUE 1

51 tonne G.L.W. LAGGED & COILED CLASS B TANK WAGON TU017A

EXCESS LENGTH	4	H	M	L	E
tonnes	51	51	14	14	
VB	0	0	0	0	
AB	26	26	8	8	
RA	10	8	1	1	
MAX SPEED	60	60	60	60	

TOPS CODE					
CARKND		AARKND		OPERATING PANEL 10	
T	U	B	T	U	B
C	1	3	5	3	

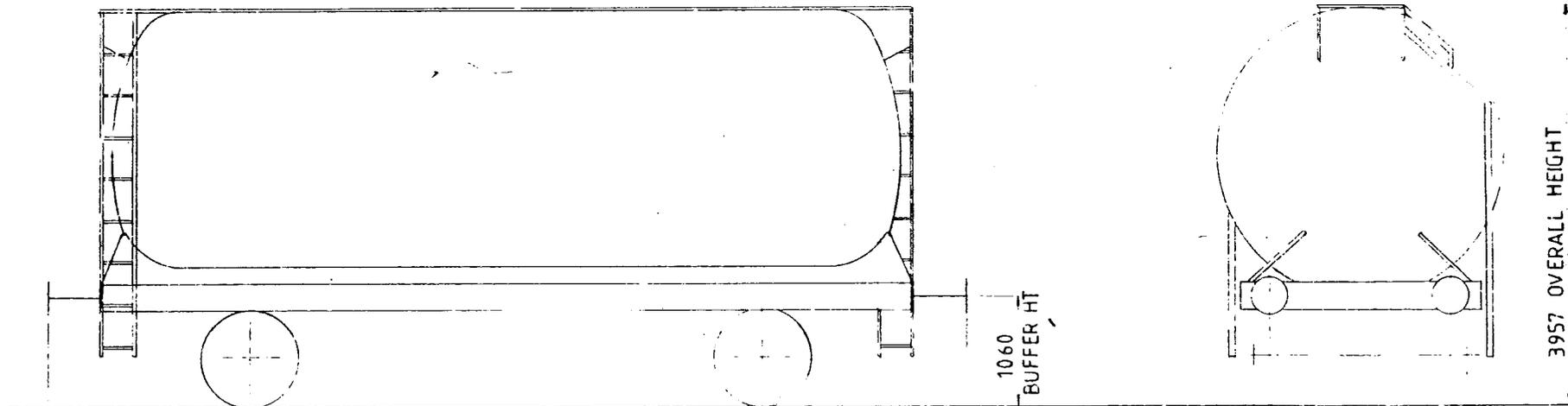

520 1470 4880 WHEELBASE 1470 520
 7820 OVER HEADSTOCKS
 8860 OVER BUFFERS

1740
 BUFFER CTRS.
 2070
 JOURNAL CTRS.
 2730
 OVERALL WIDTH

TARE -	14 200 kg
CARRYING CAPACITY -	36 300 kg
CAPACITY -	40 573 litres
MAX. SPEED -	60 m/h.
WHEELS -	952 DIA
JOURNALS -	150 DIA ROLLER BEARINGS

BUFFERS	HYDRAULIC 460 DIA HEADS
COUPLINGS	INSTANTER
MIN. CURVE -	35m SINGLY 38m CLOSE COUPLED
GEN. ARRGT. DRG. No. -	781214/01 (PROCOR LT [®])
BRAKE -	AIR BLOCK, VAC PIPE, HAND LEVER
SUSPENSION -	GLOUCESTER FLOATING AXLE

ISSUE 1