British Railways Board

Mechanical & Electrical Engineering Department

VEHICLE DIAGRAM BOOK NO 350

FOR

UNCONTROLLED DOCUMENT / ~~ISSUING~~
REFERENCE / ~~ISSUING~~ PURPOSES ONLY
THIS COPY WILL NOT BE KEPT UP TO DATE

B.R. Departmental & Service Vehicles.

© COPYRIGHT NOTICE

This PDF file has been created from the original book with permission of BRB Residuary Ltd who, retain copyright in the original document.

This PDF version is by David Faulkner, 2013.

Individuals may: use, retain and print out this PDF version for their private information or for that of their non-commercial enthusiast society or railway club.

This document and any copies produced from it in any form may not be sold or lent for any payment in any form other than to cover copying or transmission costs. No reproduction permitted in any other form or circumstance without prior permission from the original copyright holder



PREFACE

A complete list of Vehicle Diagram Books is shown below, together with new or revised book reference numbers & the colours of the respective book covers. The existing Diagram books covering Locomotives and Rail Crane vehicles which were previously shown with MT/reference numbers, have now received new covers in accordance with this revised numbering system.

REVISED VEHICLE DIAGRAM BOOK NUMBERS

Vehicle Type	Diagram Book No	Colour of Cover	Vehicle Type	Diagram Book No	Colour of Cover
<u>Locomotives:- Diagram Book Series 100</u>			<u>Freight Vehicles:- Diagram Book Series 300</u>		
Diesel Electric	100		Privately Owned Freight Vehicles	300	White
Main Line Locos	(Previously No MT/25)	Red	Privately Owned International Ferry Vehicle	310	White
Electric	110		BR Revenue Freight Vehicle	320	Buff
Main Line Locos	(Previously No MT/26)	Green	BR International Ferry Vehicles	330	Buff
Diesel Shunting Locos	120	Yellow	Foreign Administration Freight Vehicles	340	White
	(Previously No MT/27)		BR Service Department Vehicles	350	Buff
<u>Coaching & Multiple Unit Stock:- Diagram Book Series 200</u>			<u>ON Track Plant:- Diagram Book Series 400</u>		
Loco Hauled Coaches	200	Orange	Rail Cranes & Tracklaying Vehicles	400	Red
Electric Multiple Units	210	Blue		(Previously No MT/212)	
Diesel Multiple Units (Railcar)	220	Pink			
Diesel Electric Multiple Units (HST)	230	Pink			

NOVEMBER 1984

Issued by:-

Director of Mechanical & Electrical Engineering
Railway Technical Centre
DERBY

BR SERVICE DEPARTMENT VEHICLES CODE REFERENCES

YA BOGIE RAIL/SLEEPER - 'DOLPHIN' 40.5t
YB BOGIE RAIL/SLEEPER - 'STURGEON' 51t
YC BOGIE RAIL/SLEEPER
YD SKIP STORAGE - 51t
YE BOGIE RAIL - 'PERCH, PORPOISE' 53.5t
YF BOGIE RAIL - FITTED LIFTING GEAR
YG BOGIE GEN. MATS - 'SEACOW SEALION & WALRUS' 40.5t
YH BOGIE BALLAST HOPPER - SIDE & CENTRE CHUTES 'WHALE' 51t
YJ BOGIE TWIN JIB CRANE
YK LONG WELDED RAIL - 'MARLIN, MANTA' 14t
YL BOGIE RAIL - 'GANE A' 40.5t
YM BOGIE RAIL - 'SALMON' 51t
YN BOGIE RAIL/BOLSTER, EX-TRAFFIC - 'PRAWN, SHRIMP, WELK'
YO BOGIE TRAVELLING CRANE
YR STORES & MATERIALS
YS MISCELLENEOUS OPERATING
YT BOGIE BRAKE VAN
YV GEN. EQUIP CARRIER
YX SPECIALIST EQUIP CARRIER
YY ELECTRIFICATION EQUIP CARRIER

SERVICE DEPARTMENT VEHICLE INDEX

DIAGRAM NO.	DESCRIPTION	DCE FISHKIND	LOT NUMBERS
YA 500B	RAIL SLEEPER & BALLAST WAGON	DOLPHIN	2217
YA 500C	RAIL SLEEPER & BALLAST WAGON	DOLPHIN	NO LOT NUMBER
YA 500D	RAIL SLEEPER & BALLAST WAGON	DOLPHIN	NO LOT NUMBER
YA 500E	RAIL SLEEPER & BALLAST WAGON	DOLPHIN	NO LOT NUMBER
YB 500A	RAIL SLEEPER & BALLAST WAGON	STURGEON	2322, 2404
YB 500B	RAIL SLEEPER & BALLAST WAGON	STURGEON	2507, 2614, 2895
YB 500C	RAIL SLEEPER & BALLAST WAGON	STURGEON	2937, 3047
YB 500D	RAIL SLEEPER & BALLAST WAGON	STURGEON	3264, 3265, 3291, 3342
YB 500E	RAIL SLEEPER & BALLAST WAGON	STURGEON	2614, 2895
YB 500G	RAIL SLEEPER & BALLAST WAGON	STURGEON	2322, 2404
YB 500H	RAIL SLEEPER & BALLAST WAGON	STURGEON	2507, 2614, 2895
YB 500J	RAIL SLEEPER & BALLAST WAGON	STURGEON	2937, 3047
YB 500L	RAIL SLEEPER & BALLAST WAGON	STURGEON	2507
YB 500M	RAIL SLEEPER & BALLAST WAGON	STURGEON	2937
YB 501A	RAIL SLEEPER & BALLAST WAGON	STURGEON	2322, 2404, 2507, 2614, 2895, 2937
YB 501B	RAIL SLEEPER & BALLAST WAGON	STURGEON	3265
YB 502B	RAIL SLEEPER & BALLAST WAGON	STURGEON	2614
YC 500A	RAIL SLEEPER & BALLAST WAGON	PILCHARD	2121
YC501A	BALLAST WAGON	HALIBUT	4006
YD 001A	SKIP STORAGE WAGON	SKATE	4005
YE 001A	NOT YET ISSUED		4015
YE 002A	NOT YET ISSUED		4016

DIAGRAM NO.	DESCRIPTION	DCE FISHKIND	LOT NUMBERS
YF 001A	NOT YET ISSUED		2363, 2534
YF 002A	NOT YET ISSUED		2615
YF 003A	NOT YET ISSUED		2894, 2926, 3065, 3067
YF 004A	NOT YET ISSUED		3261, 3262, 3353
YF 005A	NOT YET ISSUED		3262, 3284, 3352
YF 006A	NOT YET ISSUED		2926, 3065, 3067
YF 006B	NOT YET ISSUED		3067
YF 007A	NOT YET ISSUED		2937
YF 007B	NOT YET ISSUED		2937, 3047
YF 008A	NOT YET ISSUED		2507, 2614, 2895
YF 008B	NOT YET ISSUED		2507, 2614, 2895
YG 500A	BALLAST HOPPER	SEACOW	3724, 3777
YG 500B	BALLAST HOPPER	SEALION	2723, 3802
YG 500C	BALLAST HOPPER	WALRUS	2411
YG 500F	BALLAST HOPPER	WALRUS	NO LOT NUMBERS
YG 500G	BALLAST HOPPER	SEALION	3802
YG 500H	BALLAST HOPPER	SEACOW	3966, 4010
YG 500J	NOT YET ISSUED	WALRUS	2411
YH 500A	BALLAST HOPPER	WHALE	3591
YH 500B	BALLAST HOPPER	WHALE	3591
YJ 008B	NOT ISSUED YET		NO LOT NUMBERS
YJ 009A	NOT ISSUED YET		NO LOT NUMBERS
YJ 009D	TRACKLAYER		NO LOT NUMBERS
YJ 009F	TRACKLAYER		NO LOT NUMBERS
YJ 009G	TRACKLAYER		NO LOT NUMBERS
YJ 009I	TRACKLAYER		NO LOT NUMBERS
YJ 009J	TRACKLAYER		NO LOT NUMBERS
YJ 009L	TRACKLAYER		NO LOT NUMBERS
YJ 010A	TRACKLAYER		NO LOT NUMBERS
YJ 011A	TRACKLAYER		NO LOT NUMBERS
YJO 13A	NOT ISSUED YET		26
YJO 15A	TRACKLAYER		NO LOT NUMBERS

DIAGRAM NO.	DESCRIPTION	DCE FISHKIND	LOT NUMBERS
YJO 16A	TRACKLAYER		NO LOT NUMBERS
YJO 16B	TRACKLAYER		NO LOT NUMBERS
YJO 17A	NOT ISSUED YET		NO LOT NUMBERS
YJO 18A	TRACKLAYER		NO LOT NUMBERS
YJO 19A	TRACKLAYER		NO LOT NUMBERS
YK 500A	LONG WELDED RAIL CARRIER	MANTA	3717
YK 500B	LONG WELDED RAIL CARRIER	MARLIN	3717
YL 001A	41t BOGIE RAIL WAGON	GANE A	2208
YL 002A	41t BOGIE RAIL WAGON	GANE A	2094, 2208
YL 002B	41t BOGIE RAIL WAGON	GANE A	2208
YL 003A	41t BOGIE RAIL WAGON	GANE A	4012
YL 500A	41t BOGIE RAIL WAGON	GANE A	NO LOT NUMBERS
YL 500B	41t BOGIE RAIL WAGON	GANE A	1214, 1290
YL 500C	41t BOGIE RAIL WAGON	GANE A	1214, 1290
YL 500D	41t BOGIE RAIL WAGON	GANE A	1378, 1415, 1440, 1463, 1533
YL 500E	41t BOGIE RAIL WAGON	GANE A	NO LOT NUMBERS
YM 500A	BOGIE RAIL WAGON	SALMON	2011, 2216, 2399
YM 500B	BOGIE RAIL WAGON	SALMON	2363, 2534
YM 500C	BOGIE RAIL WAGON	SALMON	2615
YM 500D	BOGIE RAIL WAGON	SALMON	2894, 2926, 3065, 3067
YM 500E	BOGIE RAIL WAGON	SALMON	1146
YM 500F	BOGIE RAIL WAGON	SALMON	1159
YM 500G	BOGIE RAIL WAGON	SALMON	1286, 1292
YM 500H	BOGIE RAIL WAGON	SALMON	1319
YM 500J	BOGIE RAIL WAGON	SALMON	3262, 3284, 3352
YM 500K	BOGIE RAIL WAGON	SALMON	3261, 3262, 3204, 3353
YM 500L	BOGIE RAIL WAGON	SALMON	2363
YM 500M	BOGIE RAIL WAGON	SALMON	2926
YM 500N	BOGIE RAIL WAGON	SALMON	2894, 2926, 3065, 3067
YM 500P	BOGIE RAIL WAGON	SALMON	2894, 2926, 3065, 3067
YM 500Q	BOGIE RAIL WAGON	SALMON	3284, 3352
YM 500R	BOGIE RAIL WAGON	SALMON	3262, 3284, 3352
YM 500S	BOGIE RAIL WAGON	SALMON	2926, 3065

DIAGRAM NO.	DESCRIPTION	DCE FISHKIND	LOT NUMBERS
YM 500T	BOGIE RAIL WAGON	SALMON	2534
YM 500U	BOGIE RAIL WAGON	SALMON	2615
YM 500W	BOGIE RAIL WAGON	SALMON	2216, 2399
YM 500Z	BOGIE RAIL WAGON	SALMON	2534
YN 004A	BOGIE BOLSTER WAGON		2271, 2309, 2406
YN 004B	BOGIE BOLSTER WAGON		2308
YN 005A	BOGIE BOLSTER WAGON		2540
YN 006A	BOGIE BOLSTER WAGON		2308
YN 007A	BOGIE BOLSTER WAGON		2759
YN 010B	BOGIE BOLSTER WAGON		2583
YN 011B	BOGIE RAIL WAGON		NO LOT NUMBER
YN 012B	BOGIE RAIL WAGON		2098
YN 014B	BOGIE BOLSTER WAGON		NO LOT NUMBER
YN 015B	BOGIE RAIL WAGON		NO LOT NUMBER
YN 018B	BOGIE BOLSTER WAGON		NO LOT NUMBER
YN 021A	BOGIE BOLSTER WAGON		NO LOT NUMBER
YN 024A	BOGIE BOLSTER WAGON	PRAWN	1469
YN 027B	BOGIE BOLSTER WAGON		1547
YN 030A	BOGIE BOLSTER WAGON	PRAWN	0988
YN 031A	BOGIE BOLSTER WAGON	PRAWN	1292
YN 034A	BOGIE PLATE WAGON	WHELK	2010, 2455, 2618, 2852, 3046
YN 035A	BOGIE PLATE WAGON	WHELK	2133
YN 036A	BOGIE BOLSTER WAGON		NO LOT NUMBER
YN 037A	BOGIE PLATE WAGON		NO LOT NUMBER
YN 038A	BOGIE PLATE WAGON		1422
YN 041C	BOGIE BOLSTER WAGON		3104, 3113
YN 043B	BOGIE BOLSTER WAGON		2760
YN 044A	BOGIE STEEL CARRIER		3896
YN 046A	NOT YET ISSUED		2021
YN 047A	NOT YET ISSUED		3343, 3440
YN 048A	NOT YET ISSUED		3155, 3162, 3200, 3238, 3341, 3397

DIAGRAM NO.	DESCRIPTION	DCE FISHKIND	LOT NUMBER
YN 050A	NOT YET ISSUED		3246
YN 050B	NOT YET ISSUED		3246
YN 051A	NOT YET ISSUED		3407, 3408
YN 053A	NOT YET ISSUED		3268, 3333
YN 053B	NOT YET ISSUED		3333
YN 054B	NOT YET ISSUED		3263
YN 055A	NOT YET ISSUED		3334
YN 056B	NOT YET ISSUED		3268, 3333
YN 057A	NOT YET ISSUED		3888
YN 500B	BOGIE BOLSTER WAGON	SHRIMP	2497
YN 505D	NOT YET ISSUED		NO LOT NUMBERS
YN 505E	BOGIE BOLSTER WAGON		NO LOT NUMBERS
YN 505F	NOT YET ISSUED		NO LOT NUMBERS
YN 507A	BOGIE BOLSTER WAGON		1497
YO 001A	NOT YET ISSUED		NO LOT NUMBERS
YO 002A	BOGIE TRAVELLING CRANE		NO LOT NUMBERS
YO 003A	BOGIE TRAVELLING CRANE		NO LOT NUMBERS
YO 003B	BOGIE TRAVELLING CRANE		NO LOT NUMBERS
YO 004A	NOT YET ISSUED		NO LOT NUMBERS
YO 005A	BOGIE TRAVELLING CRANE		NO LOT NUMBERS
YO 006A	NOT YET ISSUED		NO LOT NUMBERS
YO 007B	BOGIE TRAVELLING CRANE		NO LOT NUMBERS
YO 008A	BOGIE TRAVELLING CRANE		2614
YO 009A	BOGIE TRAVELLING CRANE		NO LOT NUMBERS
YO 010A	BOGIE TRAVELLING CRANE		NO LOT NUMBERS
YO 010B	BOGIE TRAVELLING CRANE		NO LOT NUMBERS
YO 011A	BOGIE TRAVELLING CRANE		NO LOT NUMBERS
YO 013A	NOT YET ISSUED		NO LOT NUMBERS

DIAGRAM NO.	DESCRIPTION	DCE FISHKIND	LOT NUMBER
YR 001A	STORES & MATERIALS DEN PARTS		3165, 3259, 3299
YR 002A	WELTROL		3102, 3192
YR 003A	NOT YET ISSUED		3241
YR 003B	NOT YET ISSUED		3251
YR 006A	NOT YET ISSUED		3213
YR 008A	NOT YET ISSUED		3343
YR 012A	NOT YET ISSUED		3343
YR 012B	NOT YET ISSUED		3343
YR 013A	NOT YET ISSUED		3494
YR 014A	NOT YET ISSUED		3229
YR 015A	NOT YET ISSUED		3229
YR 017A	NOT YET ISSUED		2944, 3044
YR 017B	NOT YET ISSUED		3044
YR 018A	NOT YET ISSUED		2487, 2624
YR 019A	NOT YET ISSUED		3028
YR 500A	NOT YET ISSUED		NO LOT NUMBER
YR 500B	NOT YET ISSUED		1600
YS 001A	NOT YET ISSUED		2406
YS 003B	NOT YET ISSUED		3414
YS 005A	NOT YET ISSUED		2133
YS 006A	NOT YET ISSUED		1497
YS 009A	NOT YET ISSUED		1225
YS 010A	NOT YET ISSUED		1517
YS 011C	NOT YET ISSUED		1048, 1073
YS 011D	CRANE RUNNER		1189
YS 012B	NOT YET ISSUED		3044
YS 013B	NOT YET ISSUED		NO LOT NUMBER
YS 014B	NOT YET ISSUED		0937
YS 015A	NOT YET ISSUED		1422
YS 016B	NOT YET ISSUED		NO LOT NUMBER
YS 020A	NOT YET ISSUED		2583
YS 021B	NOT YET ISSUED		1382
YS 023A	NOT YET ISSUED		2583
YS 025A	NOT YET ISSUED		3265

2305/02551/7

DIAGRAM NO.	DESCRIPTION	DCE FISHKIND	LOT NUMBERS
YS 026A	NOT YET ISSUED		2582
YS 027A	NOT YET ISSUED		3229
YS 029A	NOT YET ISSUED		3407
YS 500A	NOT YET ISSUED		2534
YS 507A	NOT YET ISSUED		2614
YT 500A	NOT YET ISSUED		NO LOT NUMBER
YT 500C	NOT YET ISSUED		NO LOT NUMBER
YV 001B	TROLLEY FLAT		3416
YV 001C	CRIPPLE CARRIER		3416
YV 002A	FLAT WAGON		3044
YV 003C	NOT YET ISSUED		2066
YV 004A	FLATROL		2219
YV 005A	NOT YET ISSUED		3269, 3270
YV 006A	FLATROL		3303
YV 007A	WELTROL		3192
YV 009B	CRIPPLE CARRIER		NO LOT NUMBER
YV 010A	NOT YET ISSUED		2005, 2364
YV 012A	CRIPPLE CARRIER		2029
YV 012C	NOT YET ISSUED		2029
YV 012D	NOT YET ISSUED		2029
YV 013B	NOT YET ISSUED		2537
YV 014A	NOT YET ISSUED		2637
YV 015A	NOT YET ISSUED		2977
YV 016A	WELTROL		3102, 3192
YV 017A	NOT YET ISSUED		3193, 3194
YV 017B	NOT YET ISSUED		3194
YV 018B	NOT YET ISSUED		1276
YV 020A	NOT YET ISSUED		3265
YV 020B	NOT YET ISSUED		3266
YV 021A	BOGIE BOLSTER WAGON		NO LOT NUMBER
YV 022A	NOT YET ISSUED		3312
YV 023C	NOT YET ISSUED		2308, 2326, 2406
YV 023D	NOT YET ISSUED		2308
YV 024B	NOT YET ISSUED	3235, 3236	

2305/02551/8

DIAGRAM NO	DESCRIPTION	DCE FISHKIND	LOT NUMBERS
YV 024C	NOT YET ISSUED		3236
YV 031A	NOT YET ISSUED		2364
YV 032A	NOT YET ISSUED		2431, 3069
YV 032B	NOT YET ISSUED		2451
YV 032D	NOT YET ISSUED		3069
YV 032E	NOT YET ISSUED		3069
YV 033A	NOT YET ISSUED		3111
YV 033C	NOT YET ISSUED		2950
YV 034A	NOT YET ISSUED		3272
YV 038A	NOT YET ISSUED		0420
YV 040A	NOT YET ISSUED		2308
YV 041B	NOT YET ISSUED		NO LOT NUMBERS
YV 042A	NOT YET ISSUED		1273
YV 043A	NOT YET ISSUED		1372
YV 044B	NOT YET ISSUED		3165, 3259, 3299
YV 044C	NOT YET ISSUED		3165
YV 045B	NOT YET ISSUED		2078
YV 046A	WELTROL		3102, 3192
YV 046C	NOT YET ISSUED		3102
YV 047B	NOT YET ISSUED		3853
YV 048A	NOT YET ISSUED		NO LOT NUMBER
YV 049A	NOT YET ISSUED		NO LOT NUMBER
YV 050A	NOT YET ISSUED		3814
YV 051A	NOT YET ISSUED		2616
YV 052A	NOT YET ISSUED		2539, 2538, 2616
YV 054A	NOT YET ISSUED		3343
YV 056A	NOT YET ISSUED		3309
YV 056C	NOT YET ISSUED		3247, 3309
YV 056D	NOT YET ISSUED		3309
YV 057C	NOT YET ISSUED		3155, 3238
YV 058A	NOT YET ISSUED		3343
YV 060A	NOT YET ISSUED		3889
YV 061B	NOT YET ISSUED		2571

DIAGRAM NO.	DESCRIPTION	DCE FISHKIND	LOT NUMBERS
YV 062A	NOT YET ISSUED		2174
YV 063A	NOT YET ISSUED		2879
YV 064A	NOT YET ISSUED		2881
YV 064B	NOT YET ISSUED		2978
YV 065A	NOT YET ISSUED		2880
YV 066A	NOT YET ISSUED		2642
YV 067A	NOT YET ISSUED		3240
YV 067B	NOT YET ISSUED		3240
YV 068A	NOT YET ISSUED		3173
YV 069A	NOT YET ISSUED		3527
YV 069V	NOT YET ISSUED		3527
YV 500A	NOT YET ISSUED		3752
YV 501A	NOT YET ISSUED		3709
YV 503B	NOT YET ISSUED		3780
YV 504B	NOT YET ISSUED		3780
YX 003A	NOT YET ISSUED		3165
YX 005A	NOT YET ISSUED		2617
YX 006A	NOT YET ISSUED		2176, 2952
YX 006B	NOT YET ISSUED		2176
YX 007A	NOT YET ISSUED		2304
YX 008A	NOT YET ISSUED		2614
YX 012B	NOT YET ISSUED		1497
YX 014A	NOT YET ISSUED		3414
YX 016A	NOT YET ISSUED		3416
YX 018A	NOT YET ISSUED		2175
YX 022A	NOT YET ISSUED		2364
YX 023A	NOT YET ISSUED		2451
YX 023C	NOT YET ISSUED		2451
YX 024A	NOT YET ISSUED		3808

2305/02551/10

DIAGRAM NO.	DESCRIPTION	DCE FISHKIND	LOT NUMBERS
YX 028A	NOT YET ISSUED		1269
YX 032A	NOT YET ISSUED		1547
YX 032B	NOT YET ISSUED		1547
YX 034A	NOT YET ISSUED		3618
YX 035A	NOT YET ISSUED		3155
YX 035B	TUNNEL INSPECTION VEHICLE		4024
YX 036A	NOT YET ISSUED		3979
YX 038A	NOT YET ISSUED		2615
YX 040A	NOT YET ISSUED		3192
YX 041A	NOT YET ISSUED		NO LOT NUMBER
YX 042A	NOT YET ISSUED		NO LOT NUMBER
YX 043A	NOT YET ISSUED		3343
YX 302A	NOT YET ISSUED		NO LOT NUMBER
YX 303A	NOT YET ISSUED		NO LOT NUMBER
YX 500C	NOT YET ISSUED		2404
YX 503A	NOT YET ISSUED		2926
YX 504A	NOT YET ISSUED		NO LOT NUMBER
YX 504B	NOT YET ISSUED		2217
YX 506A	NOT YET ISSUED		NO LOT NUMBER
YX 508B	NOT YET ISSUED		3261
YX 509A	NOT YET ISSUED		3884
YX 509B	NOT YET ISSUED		NO LOT NUMBER
YX 509C	NOT YET ISSUED		3884
YX 510A	NOT YET ISSUED		NO LOT NUMBER
YY 003A	NOT YET ISSUED		3825
YY 006A	NOT YET ISSUED		2006
YY 010A	BOGIE BOLSTER WAGON		2308
YY 011B	BOGIE BOLSTER WAGON		2308
YY 012A	BOGIE BOLSTER WAGON		2542, 2583
YY 012B	NOT YET ISSUED		3926

DIAGRAM NO.	DESCRIPTION	DCE FISHKIND	LOT NUMBERS
YY 013A	BOGIE RAIL WAGON		2098
YY 014A	BOGIE BOLSTER WAGON		NO LOT NUMBERS
YY 017A	BOGIE RAIL WAGON		1273
YY 017B	BOGIE RAIL WAGON		0838, 0923
YY 018B	BOGIE RAIL WAGON		1014
YY 019A	BOGIE BOLSTER WAGON		NO LOT NUMBER
YY 021A	BOGIE RAIL WAGON		1645
YY 022B	BOGIE BOLSTER WAGON		1547
YY 023A	BOGIE BOLSTER WAGON		0349
YY 023B	BOGIE BOLSTER WAGON		0348
YY 027B	BOGIE BOLSTER WAGON		NO LOT NUMBER
YY 028A	BOGIE STEEL CARRIER		1138
YY 031A	NOT YET ISSUED		2010
YY 033A	NOT YET ISSUED		3926
YY 033B	NOT YET ISSUED		2760, 2818
YY 034A	NOT YET ISSUED		1131
YY 035A	NOT YET ISSUED		3343, 3440
YY 036A	NOT YET ISSUED		3060
YY 037A	NOT YET ISSUED		2583, 2759, 2818
YY 038A	NOT YET ISSUED		3246
YY 039A	NOT YET ISSUED		3104, 3113
YY 039B	NOT YET ISSUED		3104
YY 040A	NOT YET ISSUED		3229, 3240
YY 041A	NOT YET ISSUED		3235, 3236
YY 042A	NOT YET ISSUED		3407, 3408
YY 500A	NOT YET ISSUED		3833
YY 500B	NOT YET ISSUED		NO LOT NUMBER
YY 505A	BOGIE BOLSTER WAGON		NO LOT NUMBER

RAIL, SLEEPER & BALLAST WAGON - 'DOLPHIN'

YA 500 B

LOT NUMBER	
2217	

TOPS INFORMATION									
AARKND		OPERATING		OPERATING SPEED		BRAKE FORCE DATA		EXCESS LENGTH	
CARKND		PANEL NO.		50 mile/h UP TO		NO POWER BRAKE		13	
Y	A	O	A	O	1	3	5		
				- mile/h ABOVE		66 tonne GLW			

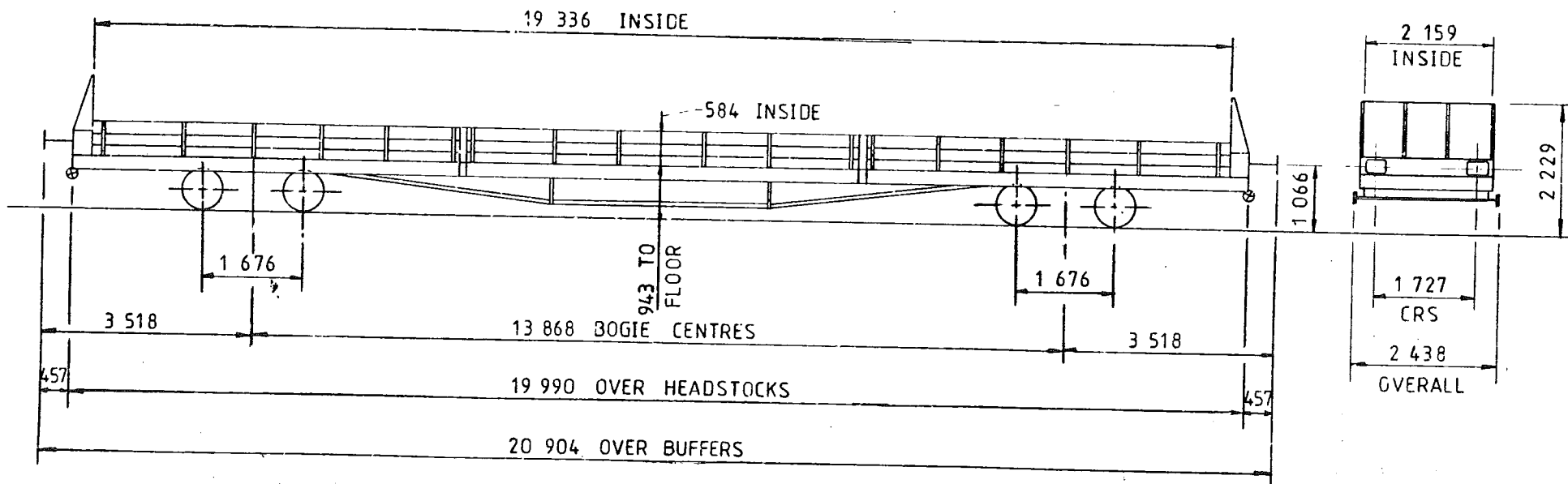

TARE -	25 500 kg
CAPACITY, WEIGHT -	40 500 kg
CAPACITY, VOLUME -	24 379 m ³
MIN. CURVE -	41m SINGLY, 75m CLOSE COUPLED
GEN. ARRG'T. DRG. N ^o .	-17188 N
	7245 C - BOGIE

BRAKE -	HAND SCREW
SUSPENSION -	SECONDARY, DIAMOND FRAME BOGIE
COUPLINGS -	INSTANTER
BUFFERS -	SELF CONTAINED, 610 x 356 OVAL HEADS
WHEELS -	762 DIA.
JOURNALS -	254 x 127 PLAIN BEARINGS

ISSUE 1

RAIL, SLEEPER & BALLAST WAGON - 'DOLPHIN'

YA 500 C

LOT NUMBER	

TOPS INFORMATION				
AARKND	OPERATING	OPERATING SPEED	BRAKE FORCE DATA	EXCESS LENGTH
CARKND	PANEL NO.	45 mile/h UP TO	NO POWER BRAKE	
Y A 0 A	8 7 8 3	mile/h ABOVE 48 tonne GLW		

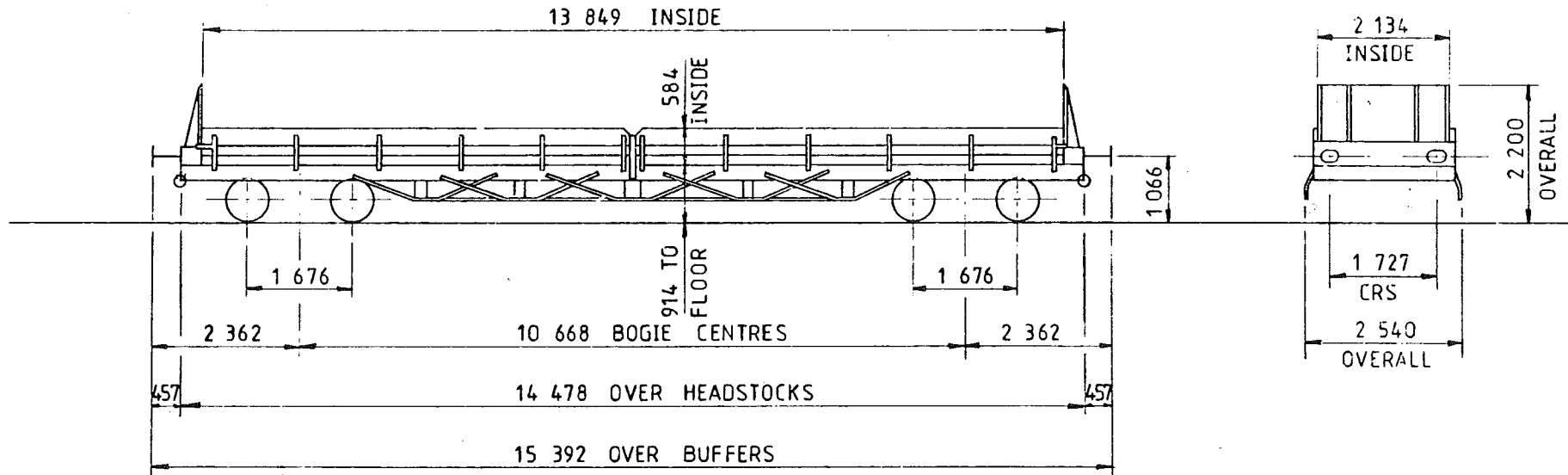

TARE -	18 250 kg
CAPACITY, WEIGHT -	30 500 kg
CAPACITY, VOLUME -	17 259 m ³
MIN. CURVE -	55m CLOSE COUPLED
GEN. ARRG ^t . DRG. N ^o .	5214 N

BRAKE -	HAND SCREW
SUSPENSION -	SECONDARY, DIAMOND FRAME BOGIE
COUPLINGS -	INSTANTER
BUFFERS -	SELF CONTAINED 610x356 OVAL HEADS
WHEELS -	762 DIA
JOURNALS -	228 x 114 PLAIN BEARINGS

ISSUE 1

RAIL, SLEEPER & BALLAST WAGON - 'DOLPHIN'

YA 500 D

LOT NUMBER	

TOPS INFORMATION									
AARKND		OPERATING		OPERATING SPEED		BRAKE FORCE DATA		EXCESS LENGTH	
CARKND		PANEL NO.		45 mile/h UP TO		NO POWER BRAKE			
Y	A	0	A	8	7	9	3	- mile/h ABOVE 65 tonne GLW	

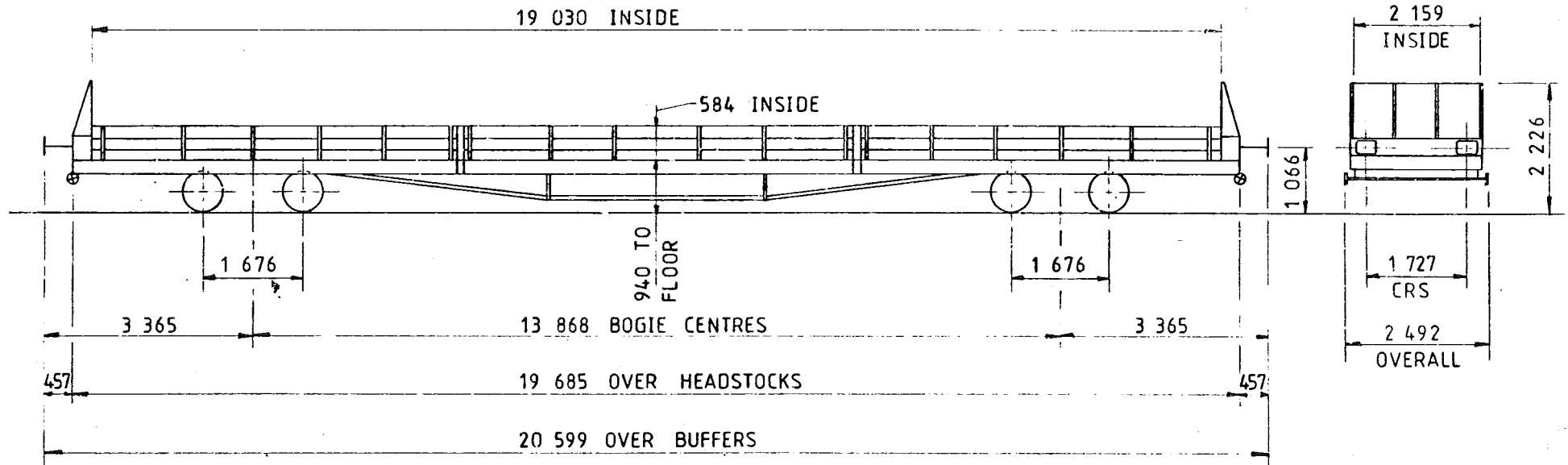

TARE -	24 900 kg
CAPACITY, WEIGHT -	40 500 kg
CAPACITY, VOLUME -	23 994 m ³
MIN. CURVE -	41m SINGLY, 75m CLOSE COUPLED
GEN. ARRGT. DRG. NO. -	

BRAKE -	HAND SCREW
SUSPENSION -	SECONDARY, DIAMOND FRAME BOGIE
COUPLINGS -	INSTANTER
BUFFERS -	SELF CONTAINED, 610x356 OVAL HEADS
WHEELS -	762 DIA.
JOURNALS -	254x127 PLAIN BEARINGS

ISSUE 1

RAIL, SLEEPER & BALLAST WAGON - 'DOLPHIN'

YA 500 E

LOT NUMBER	

TOPS INFORMATION						
AARKND	OPERATING	OPERATING SPEED		BRAKE FORCE DATA		EXCESS LENGTH
CARKND	PANEL NO.	45 mile/h UP TO		NO POWER BRAKE		
Y A O A	8 7 9 3	mile/h ABOVE 65 tonne GLW				

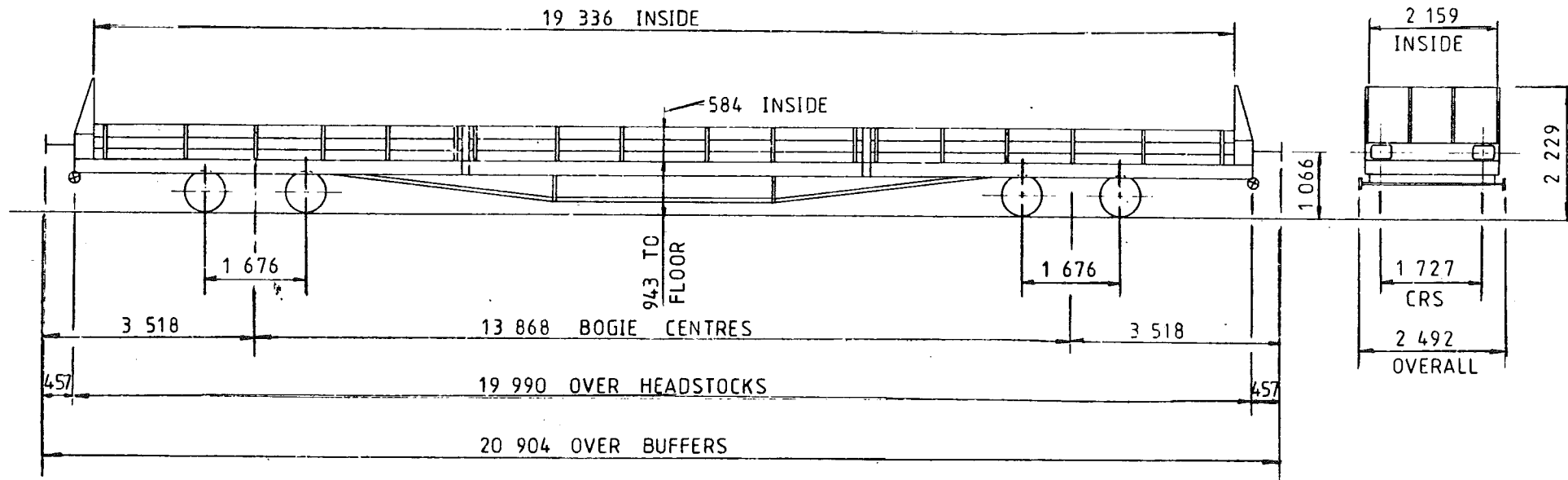

TARE -	25 500 kg
CAPACITY, WEIGHT -	40 500 kg
CAPACITY, VOLUME -	24 379 m ³
MIN. CURVE -	41m SINGLY, 75m CLOSE COUPLED
GEN. ARRGT. DRG. NO.	-11462N & 17188N 7245C - BOGIE

BRAKE -	HAND SCREW
SUSPENSION -	SECONDARY, DIAMOND FRAME BOGIE
COUPLINGS -	INSTANTER
BUFFERS -	HYDRAULIC, 533 x 330 OVAL HEADS
WHEELS -	762 DIA.
JOURNALS -	254 x 127 PLAIN BEARINGS

ISSUE 1

RAIL, SLEEPER & BALLAST WAGON - STURGEON

YB 500 A

LOT NUMBER	
2322	
2404	

TOPS INFORMATION				
AARKND	OPERATING	OPERATING SPEED		EXCESS LENGTH
CARKND	PANEL NO.	50 mile/h UP TO		13
Y B O A	0 1 3 4	- mile/h ABOVE 77 tonne GLW		
			NO POWER BRAKE	

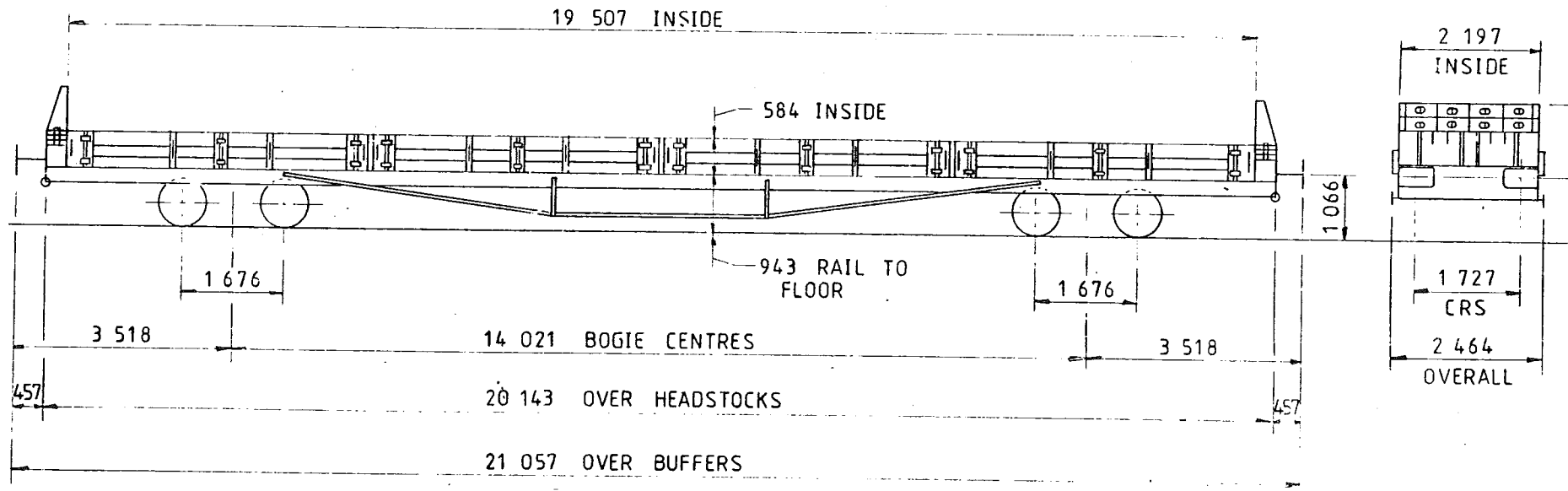

TARE -	26 050 kg
CAPACITY, WEIGHT -	51 000 kg
CAPACITY, VOLUME -	25.028 m ³
MIN. CURVE -	41m SINGLY, 76m CLOSE COUPLED
GEN. ARRGT. DRG. N ^o -	SW-ES-3 & 69 BOGIE SW-ES-4

BRAKE -	HAND SCREW
SUSPENSION -	SECONDARY
COUPLINGS -	INSTANTER
BUFFERS -	HYDRAULIC, 533 x 330 OVAL HEADS
WHEELS -	762 DIA.
JOURNALS -	280 x 140 PLAIN BEARINGS

NOTE
SIDES & STANCHIONS
REMOVABLE

ISSUE 1

RAIL SLEEPER & BALLAST WAGON - STURGEON

YB 500 B

LOT NUMBER	
2895	
2507	
2614	

TOPS INFORMATION						
AARKND		OPERATING PANEL NO.		OPERATING SPEED	BRAKE FORCE DATA	EXCESS LENGTH 13
CARKND		50 mile/h UP TO		79 tonne GLW	NO POWER BRAKE	
Y	B	O	A			mile/h ABOVE
		0	1	3	3	

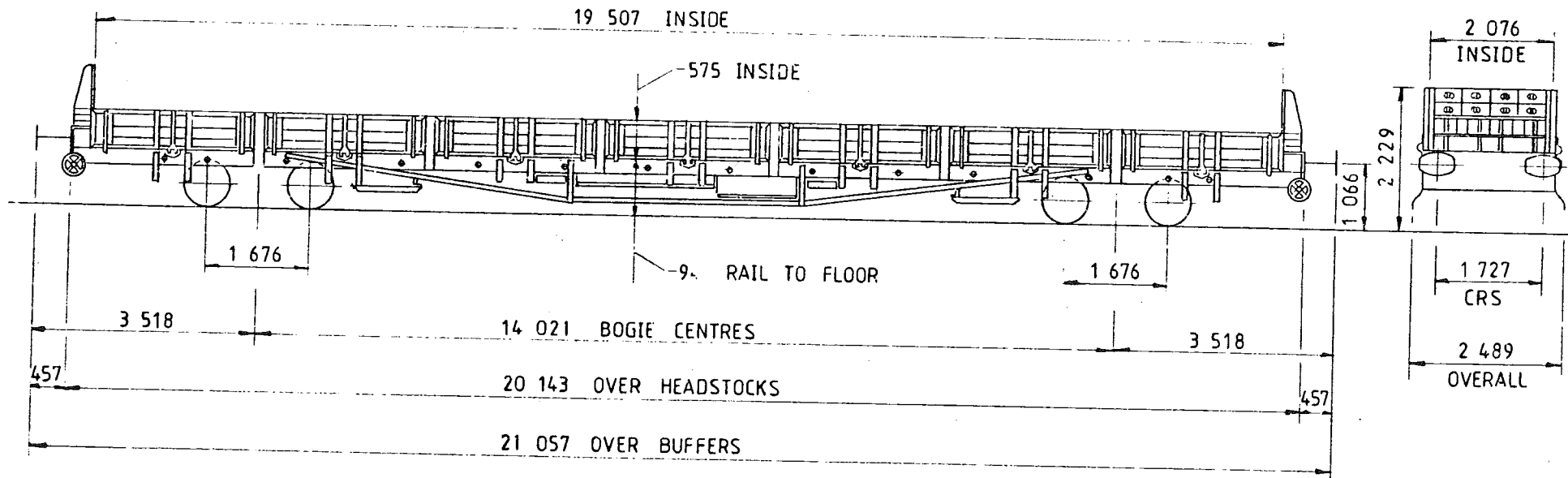

TARE -	28 350 kg
CAPACITY, WEIGHT -	51 000 kg
CAPACITY, VOLUME -	23 285 m ³
MIN. CURVE -	41m SINGLY, 76m CLOSE COUPLED
GEN ARRGT. DRG. N ^o -	SW-ES-245
BOGIE -	SW-ES-4

BRAKE -	HAND SCREW
SUSPENSION -	SECONDARY COIL
COUPLINGS -	INSTANTER
BUFFERS -	SELF CONTAINED, 559x356 OVAL HEADS
WHEELS -	762 DIA.
JOURNALS -	280 x 140 PLAIN BEARINGS

ISSUE 1

RAIL SLEEPER & BALLAST WAGON - STURGEON

YB 500C

LOT NUMBER	
7937	
3047	

TOPS INFORMATION						
AARKND		OPERATING		OPERATING SPEED		BRAKE FORCE DATA
CARKND		PANEL NO.		50 mile/h UP TO		EXCESS LENGTH
Y	B	O	A	0	2	6
						3
				- mile/h ABOVE		80 tonne GLW
				NO POWER BRAKE		14

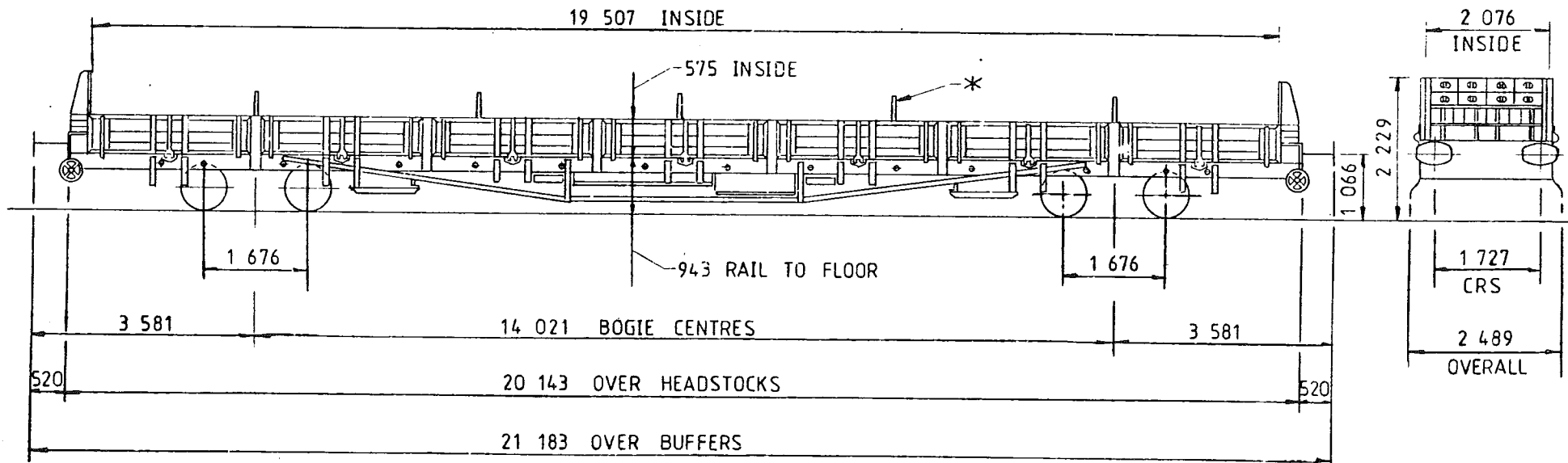

TARE -	29 450 kg
CAPACITY, WEIGHT -	51 000 kg
CAPACITY, VOLUME -	23 285 m ³
MIN. CURVE -	41m SINGLY, 76m CLOSE COUPLED
GEN ARRGT. DRG NO -	SW-ES-245
BOGIE -	SW-ES-4

BRAKE -	HAND SCREW
SUSPENSION -	SECONDARY COIL
COUPLINGS -	BR SCREW
BUFFERS -	SELF CONTAINED, 559x356 OVAL HEADS
WHEELS -	762 DIA
JOURNALS -	280x140 PLAIN BEARINGS

* FITTED WITH REMOVABLE STANCHIONS & BOLSTERS SIDES HINGED & REMOVABLE

ISSUE 1

RAIL SLEEPER & BALLAST WAGON - STURGEON

YB 500 D

LOT NUMBER	
3264	3342
3265	
3291	

TOPS INFORMATION						
AARKND	OPERATING		OPERATING SPEED		BRAKE FORCE DATA	
CARKND	PANEL N ^o		50 mile/h UP TO		NO POWER BRAKE	
Y B P A	0 2 6 2	mile/h ABOVE 80 tonne GLW				
						EXCESS LENGTH
						14

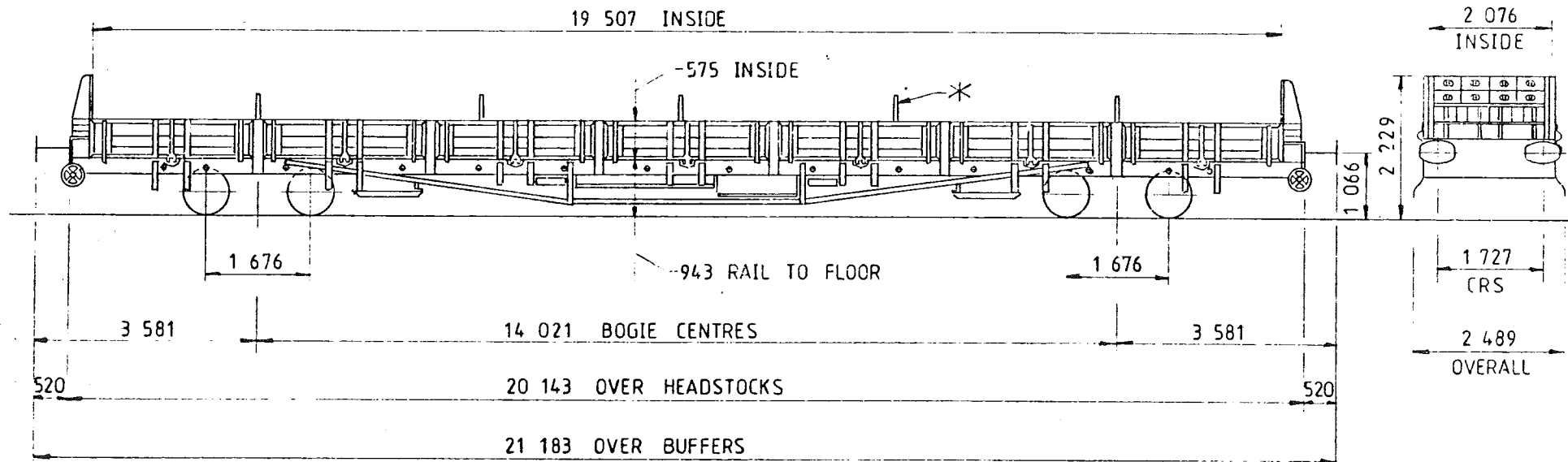

TARE -	29 450 kg
CAPACITY, WEIGHT -	51 000 kg
CAPACITY, VOLUME -	23 285 m ³
MIN. CURVE -	41m SINGLY, 76m CLOSE COUPLED
GEN ARRGT DRG N ^o -	SW-ES-245
BOGIE -	SW-ES-4

BRAKE -	VACUUM PIPED & HAND SCREW
SUSPENSION -	SECONDARY COIL
COUPLINGS -	BR SCREW
BUFFERS -	SELF CONTAINED, 559x356 OVAL HEADS
WHEELS -	762 DIA.
JOURNALS -	280x140 PLAIN BEARINGS

* FITTED WITH REMOVABLE STANCHIONS & BOLSTERS SIDES HINGED & REMOVABLE

ISSUE 1

RAIL SLEEPER & BALLAST WAGON - STURGEON

YB 500E

LOT NUMBER	
2614	
2895	

TOPS INFORMATION										
AARKND		OPERATING		OPERATING SPEED			BRAKE FORCE DATA		EXCESS LENGTH	
CARKND		PANEL N ^o		50 mile/h UP TO			NO POWER BRAKE		13	
Y	B	P	A	0	2	8				

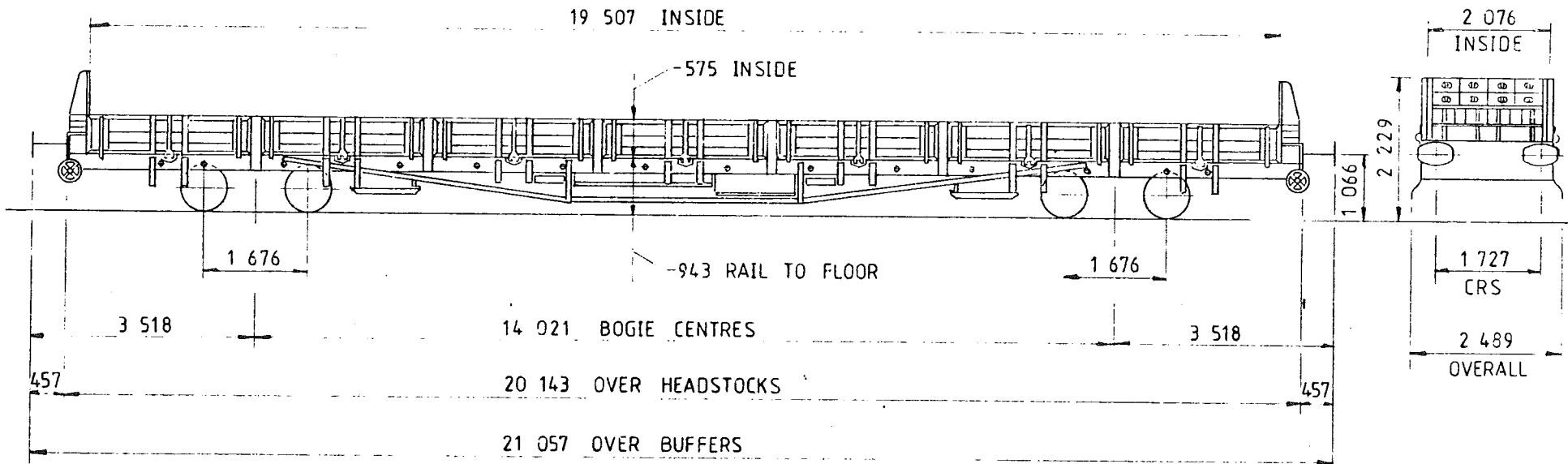

TARE -	28 450 kg
CAPACITY, WEIGHT -	51 000 kg
CAPACITY, VOLUME -	23 285 m ³
MIN. CURVE -	41m SINGLY, 76m CLOSE COUPLED
GEN. APRG ^t	DRG N ^o - SW - ES - 245
	BOGIE - SW - ES - 4

BRAKE -	VACUUM PIPED & HAND SCREW
SUSPENSION -	SECONDARY COIL
COUPLINGS -	INSTANTER
BUFFERS -	SELF CONTAINED 559x356 OVAL HEADS
WHEELS -	762 DIA.
JOURNALS -	280 x 140 PLAIN BEARINGS

ISSUE 1

RAIL, SLEEPER & BALLAST WAGON - STURGEON

YB 500 G

LOT NUMBER	
2322	
2404	

TOPS INFORMATION										
AARKND		OPERATING		OPERATING SPEED			BRAKE FORCE DATA		EXCESS LENGTH	
CARKND		PANEL NO.		50 mile/h UP TO			24t FORCE UP TO		13	
				mile/h ABOVE			78 tonne GLW			
Y	B	A	A	0	3	3	0			

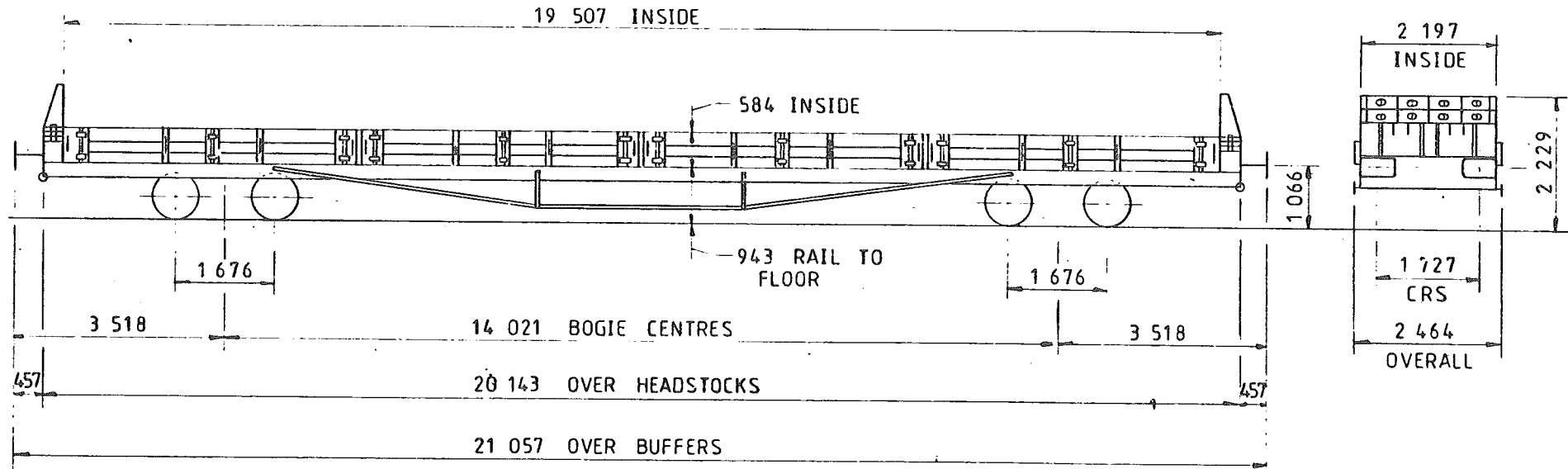

TARE -	27 000 kg
CAPACITY, WEIGHT -	51 000 kg
CAPACITY, VOLUME -	25.028 m ³
MIN. CURVE -	41m SINGLY, 76m CLOSE COUPLED
GEN. ARRGT. DRG. N ^o -	SW-ES-3 & 69 BOGIE-SW-ES-4

BRAKE -	AIR BLOCK & HAND SCREW
SUSPENSION -	SECONDARY
COUPLINGS -	INSTANTER
BUFFERS -	HYDRAULIC, 610 x 356 OVAL HEADS
WHEELS -	762 DIA.
JOURNALS -	280 x 140 PLAIN BEARINGS

NOTE
SIDES & STANCHIONS
REMOVABLE

ISSUE 1

EX. BR. DIAGRAM 638

RAIL SLEEPER & BALLAST WAGON - STURGEON

YB 500H

LOT NUMBER	
2507	
2614	
2895	

TOPS INFORMATION							
AARKND	OPERATING		OPERATING SPEED		BRAKE FORCE DATA		EXCESS LENGTH 13
CARKND	PANEL N ^o		50 mile/h UP TO		24 t FORCE UP TO		
Y B A A	0	3	2	9	80 tonne GLW		
			-mile/h ABOVE		80 tonne GLW		

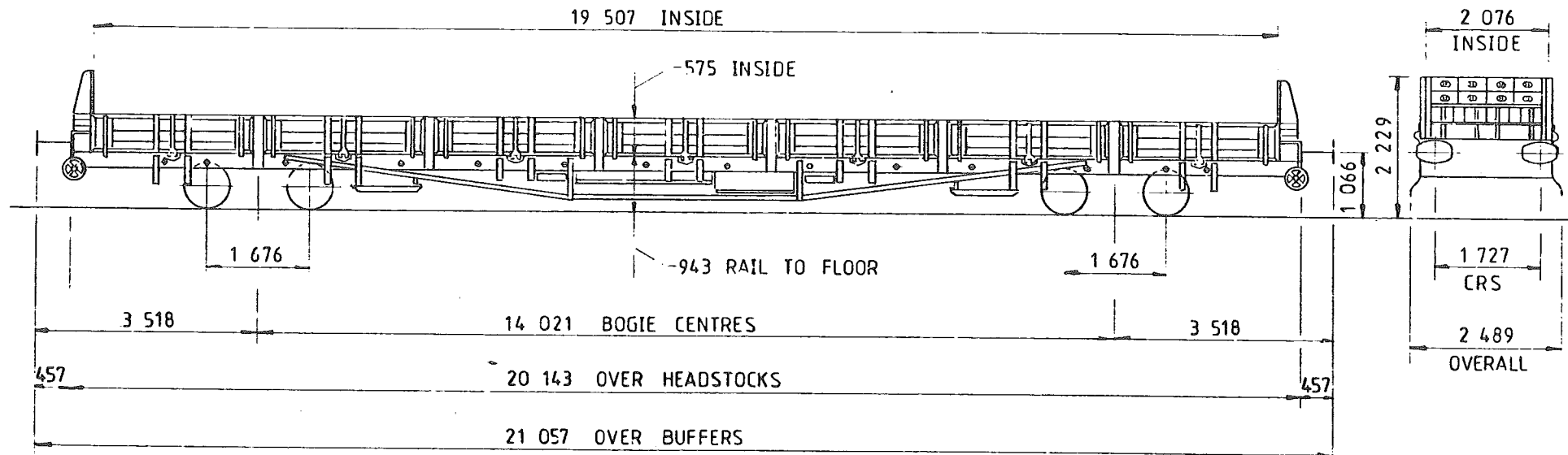

TARE -	29 000 kg
CAPACITY, WEIGHT -	51 000 kg
CAPACITY, VOLUME -	23 285 m ³
MIN CURVE -	41m SINGLY, 76m CLOSE COUPLED
GEN APPT DRG N -	SW-ES-245
BOGIE -	SW-ES-4

BRAKE -	AIR BLOCK & HAND SCREW
SUSPENSION -	SECONDARY COIL
COUPLINGS -	INSTANTER
BUFFERS -	SELF CONTAINED 559 x 356 OVAL HEADS
WHEELS -	762 DIA.
JOURNALS -	280 x 140 PLAIN BEARINGS

ISSUE 1

EX BR DIAGRAM 645

RAIL SLEEPER & BALLAST WAGON - STURGEON

YB 500J

LOT NUMBER	
2937	
3047	

TOPS INFORMATION											
AARKND		OPERATING		OPERATING SPEED			BRAKE FORCE DATA		EXCESS LENGTH		
CARKND		PANEL N ^o		50 mile/h UP TO			24 t FORCE UP TO		81		
Y	B	A	A	0	3	3	1	-mile/h ABOVE		81 tonne GLW	14
							† FORCE ABOVE				

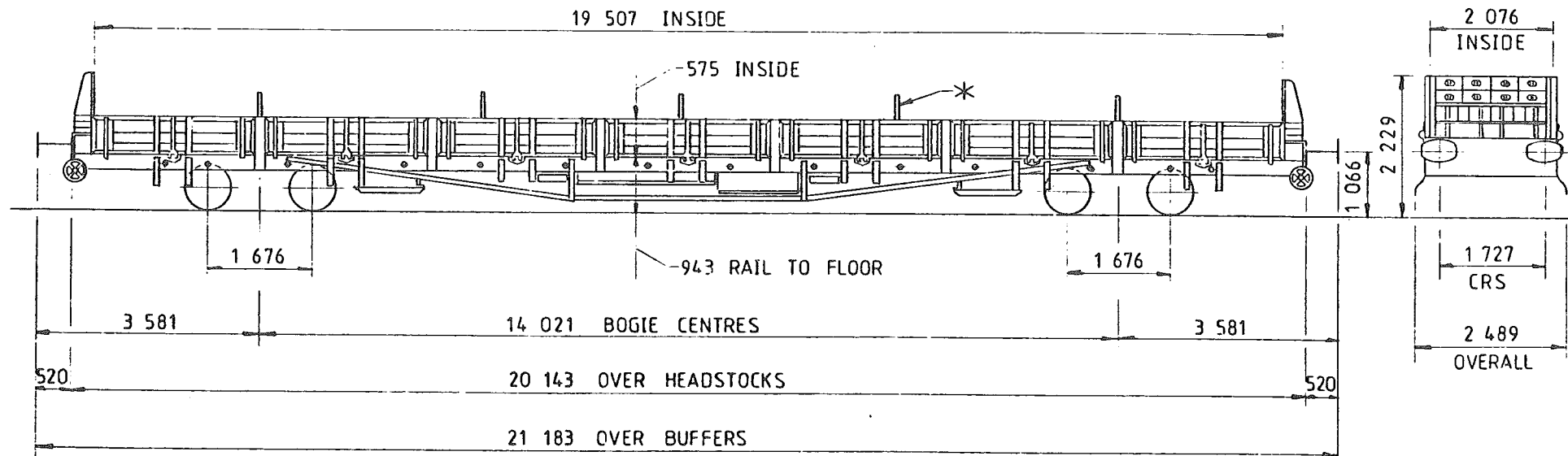

TARE -	30 000 kg
CAPACITY, WEIGHT -	51 000 kg
CAPACITY, VOLUME -	23 285 m ³
MIN CURVE -	41m SINGLY, 76m CLOSE COUPLED
GEN ARRGT, DRG N ^o -	SW-ES-245
BOGIE -	SW-ES-4

BRAKE -	AIR BLOCK & HAND SCREW
SUSPENSION -	SECONDARY COIL
COUPLINGS -	BR SCREW
BUFFERS -	SELF CONTAINED 559 x 356 OVAL HEADS
WHEELS -	762 DIA.
JOURNALS -	280 x 140 PLAIN BEARINGS

* FITTED WITH REMOVABLE STANCHIONS & BOLSTERS SIDES HINGED & REMOVABLE

ISSUE 1

EX BR DIAGRAM 647

RAIL SLEEPER & BALLAST WAGON - STURGEON

YB 500L

LOT NUMBER	
2507	

TOPS INFORMATION					
AARKND	OPERATING	OPERATING SPEED		BRAKE FORCE DATA	EXCESS LENGTH 13
CARKND	PANEL NO	50 mile/h UP TO			
Y B O B	0 1 3 3	mile/h AB VE	79 tonne GLW	NO POWER BRAKE	

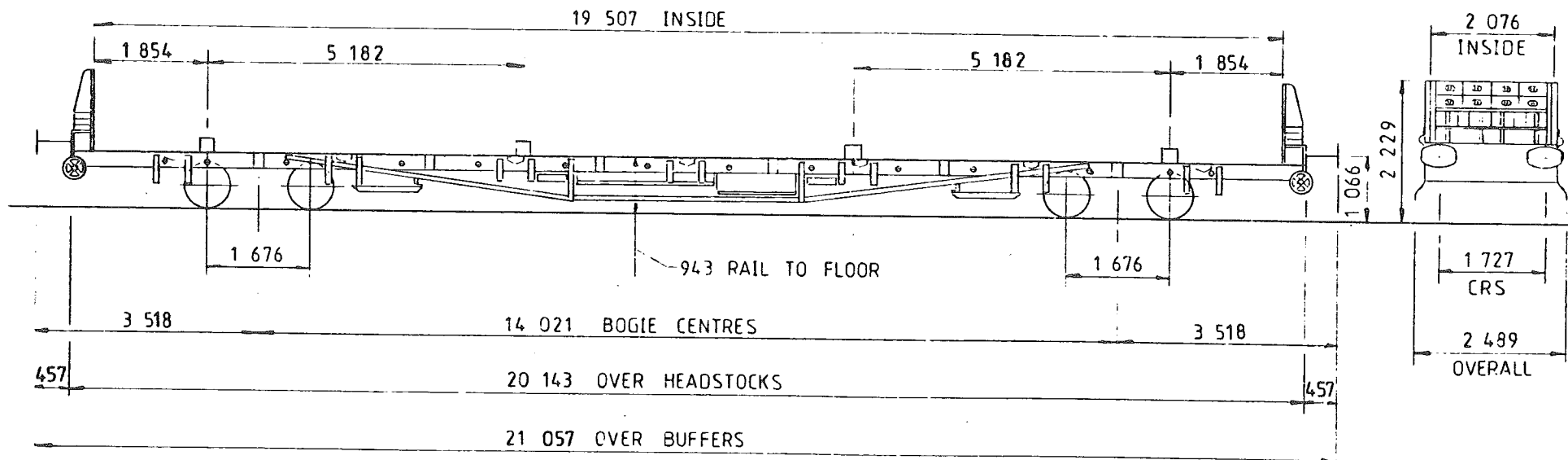

TARE -	28 000 kg
CAPACITY WEIGHT -	51 000 kg
CAPACITY VOLUME -	23 255 m ³
MIN CURVE -	41m SINGLY, 76m CLOSE COUPLED
GEN. PRIN. ORG. N.	-SW-ES-245
	BOGIE -SW-ES-4

BRAKE -	HAND SCREW
SUSPENSION -	SECONDARY COIL
COUPLINGS -	INSTANTER
BUFFERS -	SELF CONTAINED 559x356 OVAL HEADS
WHEEL -	762 DIA.
AXLES -	280x140 PLAIN BEARINGS

SCALE 1

EX. BR. DIAGRAM 645

RAIL SLEEPER & BALLAST WAGON - STURGEON

YB 500M

LOT NUMBER	
2937	

TOPS INFORMATION				
AARKND	OPERATING	OPERATING SPEED	BRAKE FORCE DATA	EXCESS LENGTH
CARKND	PANEL N _s	50 m le/h UP TO		
Y B O B	0 2 6 3	80 m/h G.W	NO POWER BRAKE	14

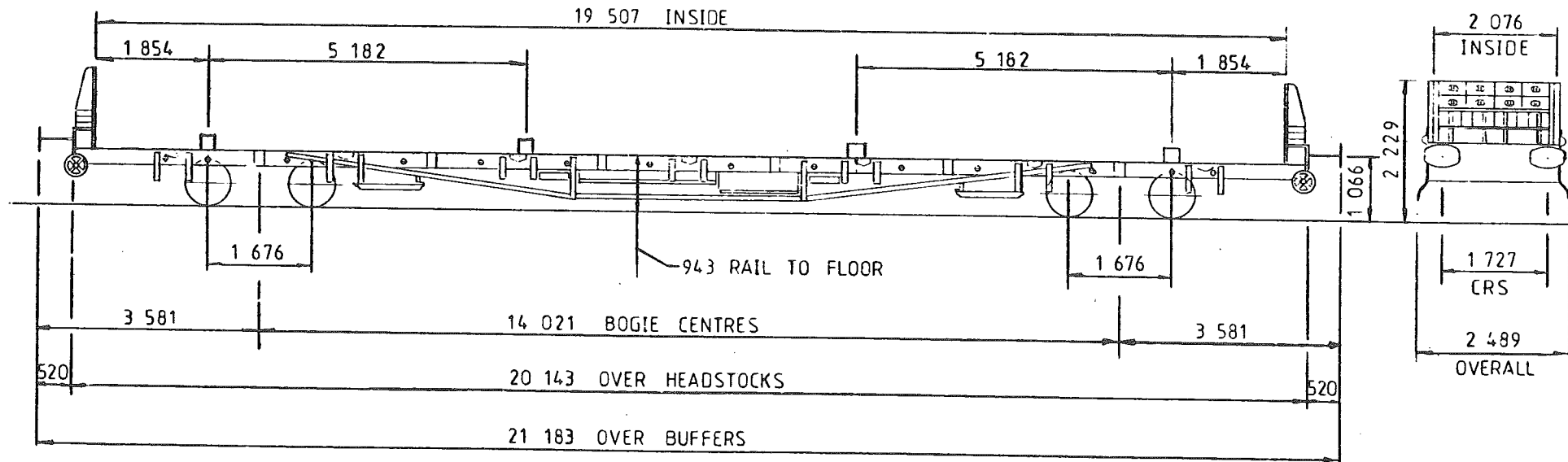

TARE -	29 000 kg
CAPACITY WEIGHT -	51 000 kg
CAPACITY VOLUME -	23 355 m ³
MIN. CURVE -	41m SINGLY, 76m CLOSE COUPLED
DRG N _s	SW-ES-245
BOGIE	SW-ES-4

BRAKE -	HAND SCREW
SUSPENSION -	SECONDARY COIL
COUPLING -	BR SCREW
BUFFER -	SELF CONTAINED 559x356 OVAL HEADS
WHEEL -	762 DIA
BEARING -	260x140 PLAIN BEARINGS

FIGURE 1

RAIL SLEEPER & BALLAST WAGON - STURGEON

YB 501A

LOT NUMBER	
2614	2507
2322	2895
2404	2937

TOPS INFORMATION				
AARKND	OPEFALING	OPERATING SPEED	BRAKE FORCE DATA	EXCESS LENGTH
CARKND	PANEL No	50 mile/h UP TO	NO POWER BRAKE	13
Y B O C	0 1 3 3	rate ABOVE 79 tonne GLW		

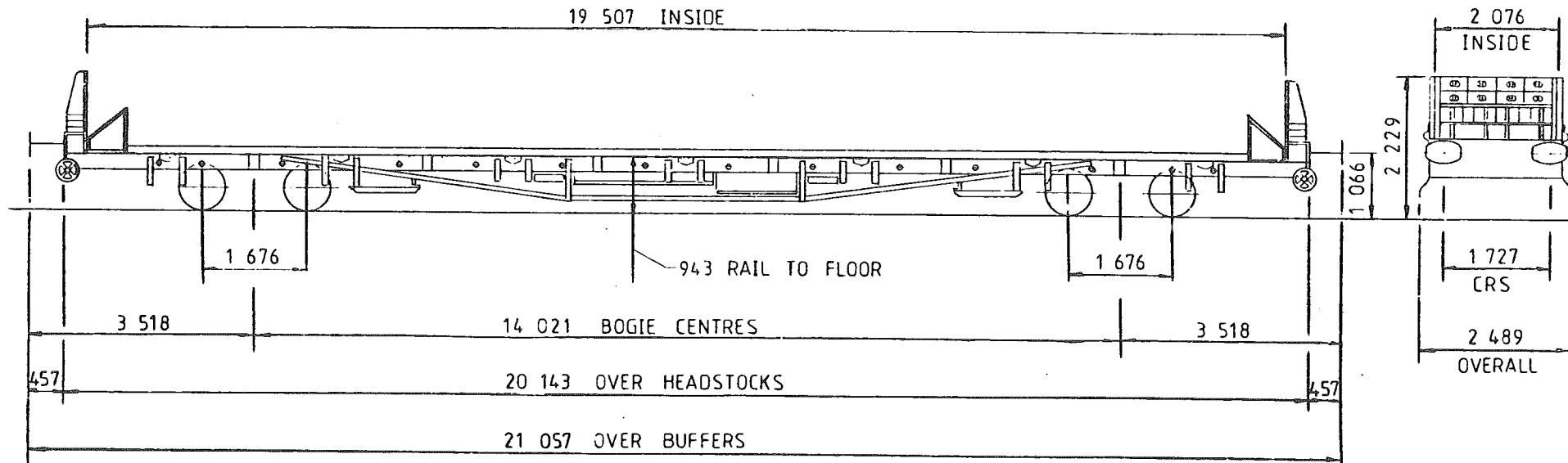

TARE -	28 000 kg
CAPACITY WEIGHT -	51 000 kg
CAPACITY VOLUME -	23 285 m ³
MIN. CURVE -	41m SINGLY, 76m CLOSE COUPLED
GEN. APPR. DRG. N. -	SW-ES-245
BOGIE -	SW-ES-4

BRAKE -	HAND SCREW
SUSPENSION -	SECONDARY COIL
COUPLINGS -	INSTANTER
BUFFERS -	SELF CONTAINED 559x356 OVAL HEADS
WHEELS -	762 DIA.
JOURNALS -	280x140 PLAIN BEARINGS

FIGURE 1

EX BR DIAGRAM 645

RAIL SLEEPER & BALLAST WAGON - STURGEON

YB 501 B

LOT NUMBER	
3265	

TOPS INFORMATION									
AARKND	OPERATING		OPERATING SPEED		BRAKE FORCE DATA			EXCESS LENGTH	
CARKND	PANEL NO		50 miles/h UP TO		NO POWER BRAKE			14	
Y B P C	0	2	6	2	80 tonne GLW				
NOTE ABOVE									

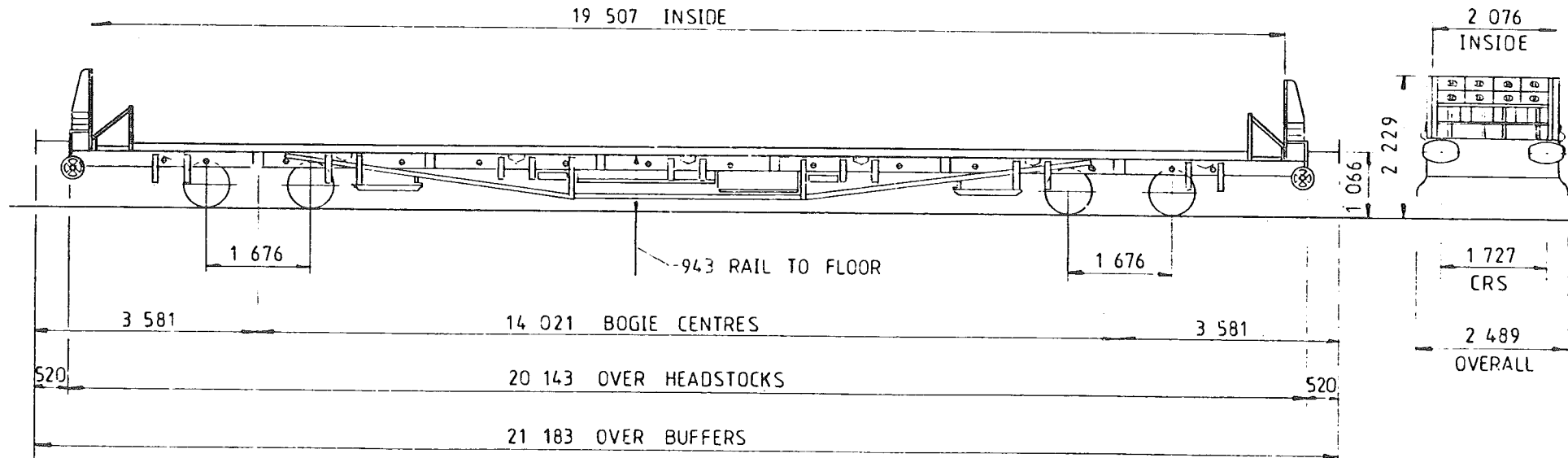

TARE	29 000 kg
CAPACITY WEIGHT	51 000 kg
CAPACITY VOLUME	23 355 m ³
MIN. CURVE	41m SINGLY, 76m CLOSE COUPLED
MIN. APPROX. DRAG NO.	SW-ES-245
BOGIE	SW-ES-4

BRAKE	VACUUM PIPED & HAND SCREW
SUSPENSION	SECONDARY COIL
COUPLING	BR SCREW
BUFFERS	SELF CONTAINED 559 x 356 OVAL HEADS
WHEELS	762 DIA
AXLES	280 x 140 PLAIN BEARINGS

FIGURE 1

RAIL SLEEPER & BALLAST WAGON - STURGEON

YB 502 B

LOT NUMBER	
2614	

TOPS INFORMATION												
AARKND		OPERATING		OPERATING SPEED				BRAKE FORCE DATA		EXCESS LENGTH		
CARKND		PANEL N ^o		50 mile/h UP TO				NO POWER BRAKE				
Y	B	Q	B	B	4	7	3	80 tonne GLW				13
				mile/h ABOVE								

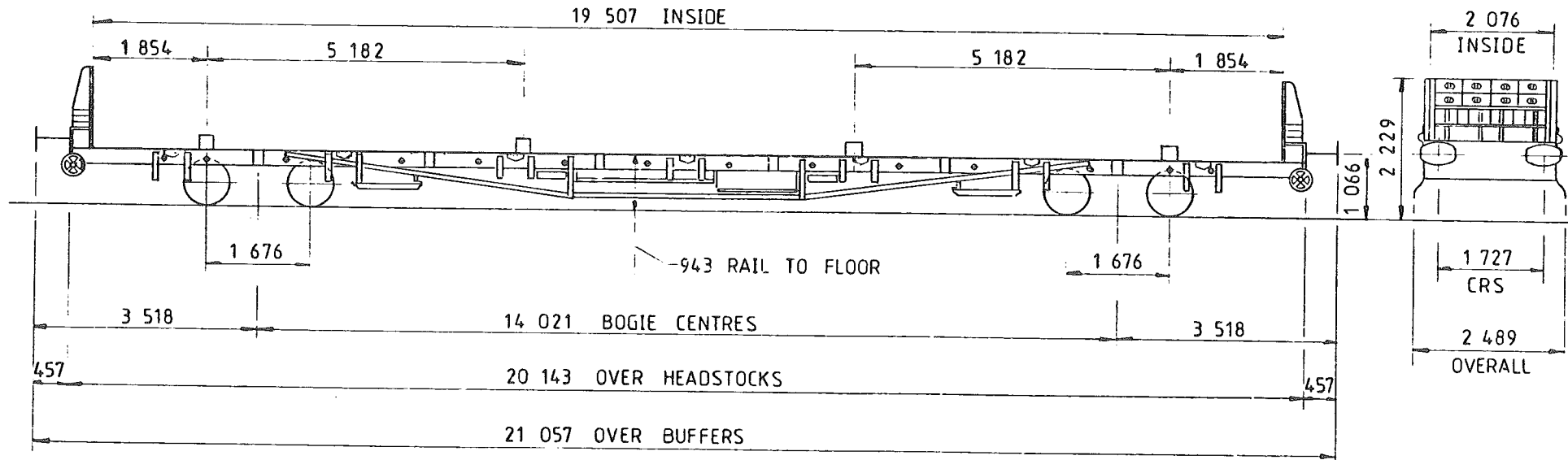

TARE -	29 000 kg
CAPACITY, WEIGHT -	51 000 kg
CAPACITY, VOLUME -	23 285 m ³
MIN. CURVE -	41m SINGLY, 76m CLOSE COUPLED
GEN. ARRGT. DRG. N ^o -	SW-ES-245
	BOGIE - SW-ES-4

BRAKE -	AIR PIPE & HAND SCREW
SUSPENSION -	SECONDARY COIL
COUPLINGS -	INSTANTER
BUFFERS -	SELF CONTAINED 559x356 OVAL HEADS
WHEELS -	762 DIA.
JOURNALS -	280x140 PLAIN BEARINGS

ISSUE 1

EX BR DIAGRAM 645

BALLAST & SLEEPER WAGON - 'PILCHARD'

YC 500 A

LOT NUMBER	
2121	

TOPS INFORMATION					
AARKND	OPERATING	OPERATING SPEED		BRAKE FORCE DATA	EXCESS LENGTH
CARKND	PANEL NO.	50 mile/h UP TO		NO POWER BRAKE	
Y C O A	0 1 1 7	mile/h ABOVE 34 tonne GLW			

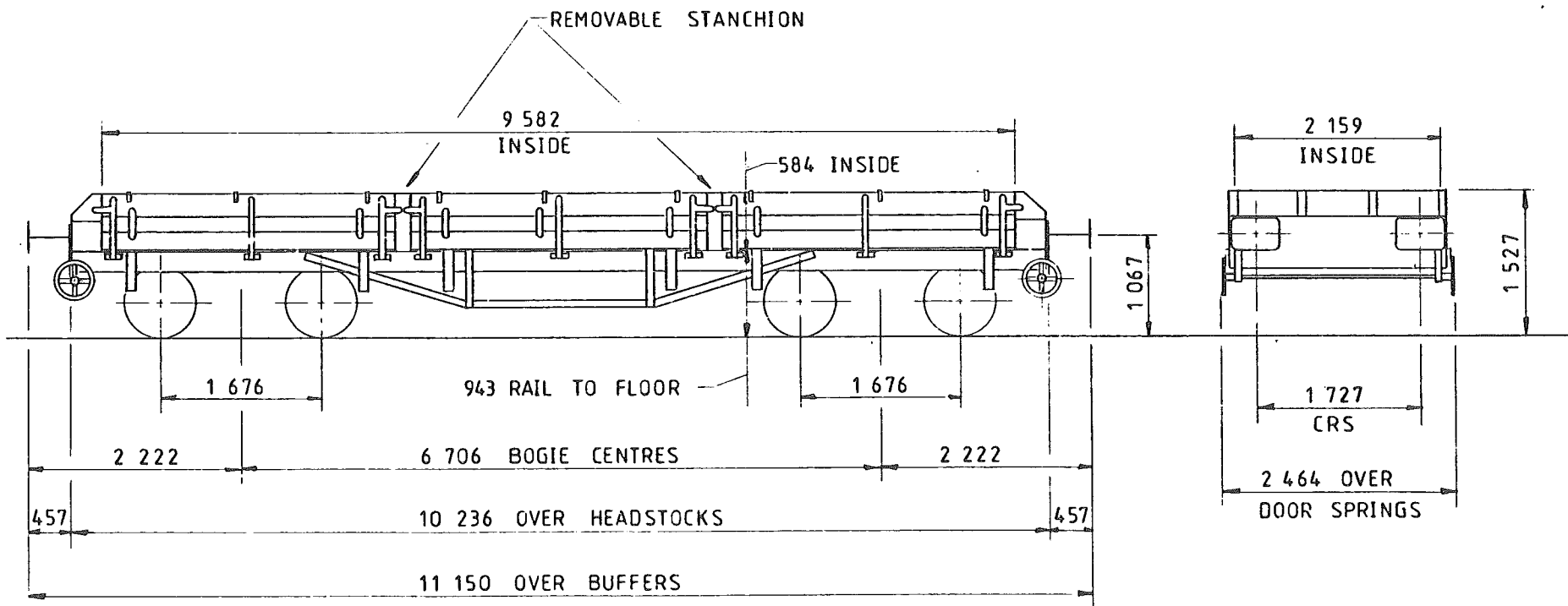

TARE -	14 600 kg
CAPACITY, WEIGHT -	20 500 kg
CAPACITY, VOLUME -	12 m ³
MIN. CURVE -	22m SINGLY, 43m CLOSE COUPLED
GEN. ARRGT. DRG. NO. -	17472 N
	BOGIE - 17444 N

BRAKE -	HAND SCREW
SUSPENSION -	SECONDARY COIL
COUPLINGS -	INSTANTER
BUFFERS -	HYDRAULIC 533x330 OVAL HEADS
WHEELS -	762 DIA.
JOURNALS -	228 x 114 PLAIN BEARINGS

ISSUE 1

EX. BR. DIAGRAM 571

BALLAST WAGON - HALIBUT

YC 501 A

LOT NUMBER	
4006	

TOPS INFORMATION											
AARKND		OPERATING		OPERATING SPEED				BRAKE FORCE DATA		EXCESS LENGTH	
CARKND		PANEL NO.		60 mile/h UP TO				18 t FORCE UP TO		0	
Y C A B		8 9 9 1		mile/h ABOVE 88 tonne GLW				40 t FORCE ABOVE 59 tonne GLW			

AUTOMATIC CHANGEOVER DEVICE

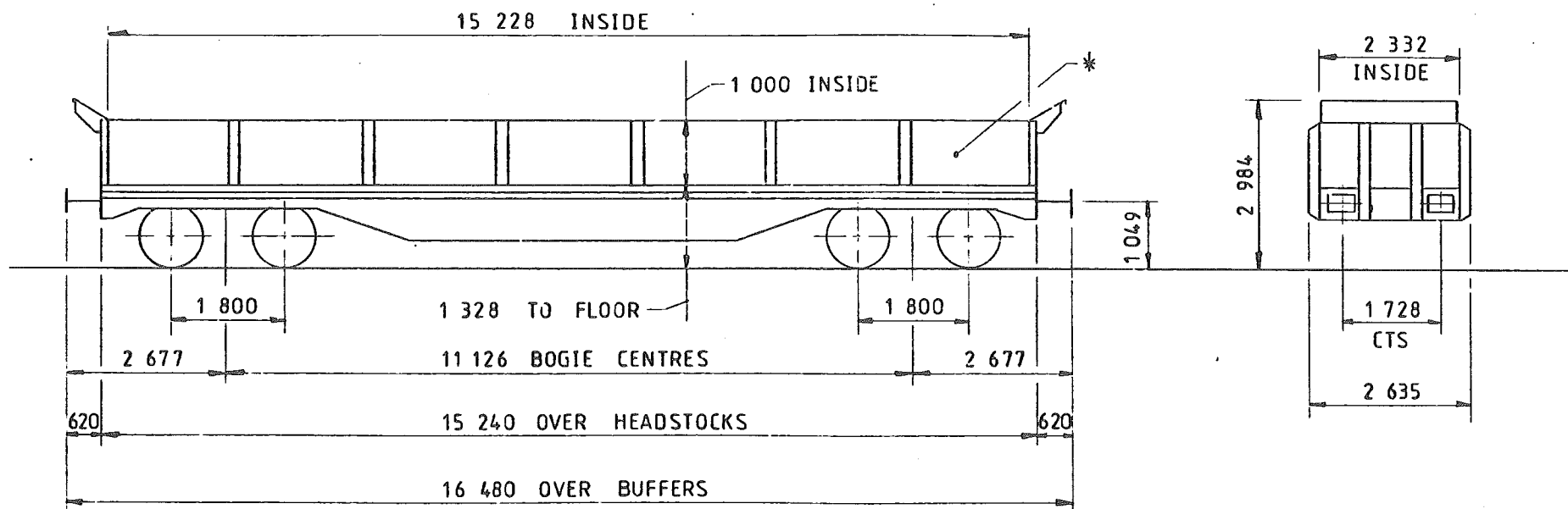

* 7 DOORS PER. SIDE
2 000 WIDE, HINGED DOWN

TARE -	28 000 kg
CAPACITY, WEIGHT -	60 000 kg
CAPACITY, VOLUME -	34 500 m ³
MIN. CURVE -	50m SINGLY, 70m CLOSE COUPLED
GEN ARRGT. DRG N ^o -	F-S-22028

BRAKE -	AIR BLOCK & HAND SCREW
SUSPENSION -	PRIMARY COIL, Y25 C _{s2} BOGIE ^{22 tonne} AXLE LOAD
COUPLINGS -	INTERNATIONAL SCREW
BUFFERS -	HYDRAULIC, 610 x 356 RECTANGULAR HEADS
WHEELS -	920 DIA.
JOURNALS -	130 DIA. ROLLER BEARINGS

ISSUE 1

DROP SIDED SPOIL WAGON TURBOT

YC 502 A

LOT NUMBER	
4021	

TOPS INFORMATION						
AARKND		OPERATING		OPERATING SPEED		BRAKE FORCE DATA
CARKND		PANEL NO.		55 mile/h UP TO 46.5		EXCESS LENGTH
Y	C	V	C	9	3	7
				tonne GLW		9t FORCE UP TO 46.5t GLW
				mile/h ABOVE		

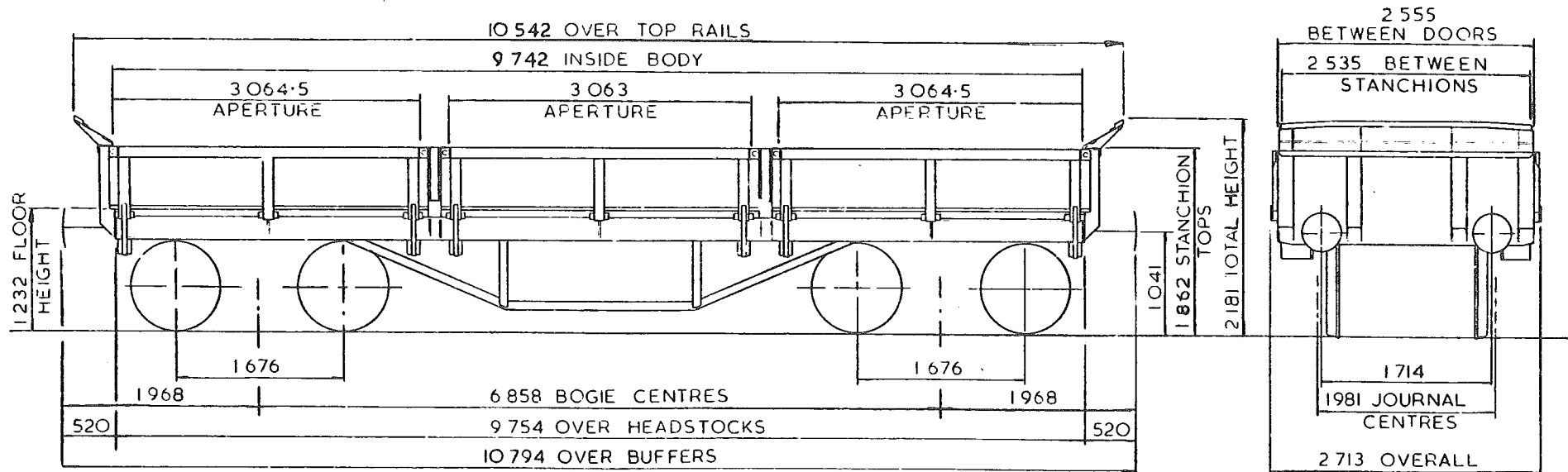

TARE - 14 000kg
CAPACITY, WEIGHT - 34 000kg
CAPACITY, VOLUME - 15.68m ³
MIN. CURVE - 31m.
GEN. ARRGT. DRG. NO. - D4-S-9 004938
BOGIE-ESCC. L.L. DRG. NO. 7591 I/S/D

BRAKE - VACUUM BLOCK & HAND LEVER
SUSPENSION - SECONDARY COIL
COUPLINGS - INSTANTER
BUFFERS - HYDRAULIC 406 DIA. HEADS
WHEELS - 914 DIAMETER
JOURNALS - III DIA. ROLLER BEARINGS

ISSUE 1

EX. BR. DIAGRAM B/479

SKIP STORAGE WAGON - 'SKATE'

YD 001 A

LOT NUMBER	
4005	

TOPS INFORMATION								
AARKND		OPERATING		OPERATING SPEED		BRAKE FORCE DATA		EXCESS LENGTH
CARKND		PANEL NO.		60 mile/h UP TO		22 t FORCE UP TO		0
Y D A A		8 5 3 4		mile/h ABOVE		47 tonne GLW		40 t FORCE ABOVE
						47 tonne GLW		

AUTOMATIC CHANGEOVER DEVICE

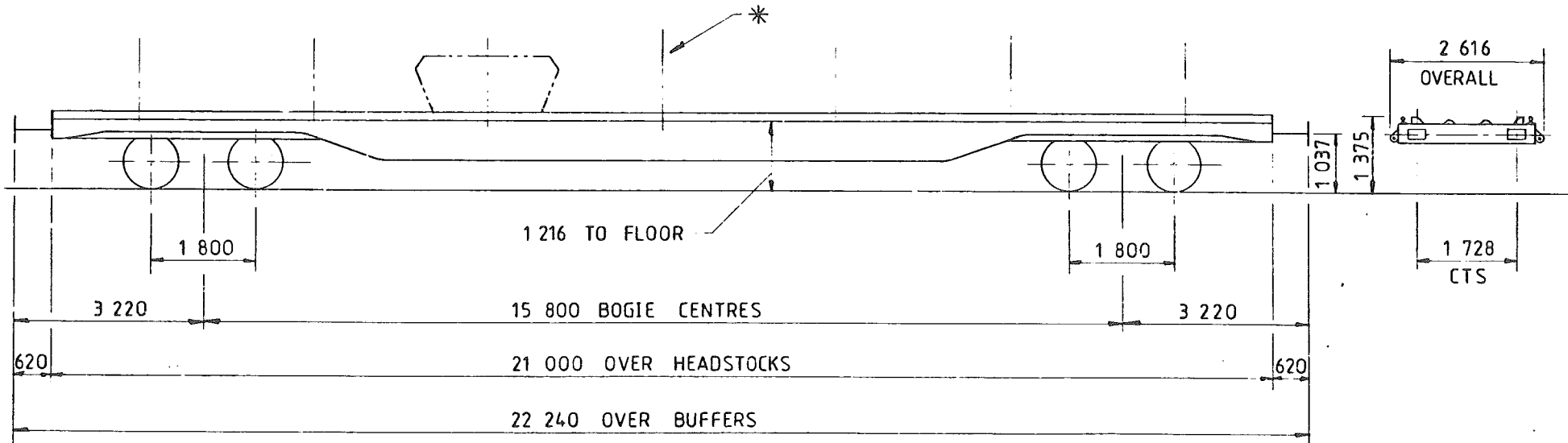

TARE -	26 000 kg
CAPACITY, WEIGHT -	51 000 kg
CAPACITY, VOLUME -	
MIN. CURVE -	50m SINGLY, 100m CLOSE COUPLED
GEN ARRGT DRG NO. -	F-A0-21626
	BOGIE - C1-A1-7000273

BRAKE -	AIR BLOCK & HAND SCREW
SUSPENSION -	PRIMARY COIL, Y25Csm BOGIE
COUPLINGS -	INTERNATIONAL SCREW
BUFFERS -	HYDRAULIC, 610x356 RECTANGULAR HEADS
WHEELS -	920 DIA.
JOURNALS -	130 DIA. ROLLER BEARINGS

* CENTRE LINE OF SKIPS
7 PER. WAGON

ISSUE 1

BALLAST HOPPER - 'SEALION'

YG 500 B

LOT NUMBER	
3723	
3802	

TOPS INFORMATION				
AARKND	OPERATING	OPERATING SPEED		EXCESS LENGTH
CARKND	PANEL NO	60 mile/h UP TO		37.5 tonne GLW
Y G H B	0 2 5 7	-mile/h ABOVE		

AUTOMATIC CHANGEOVER DEVICE

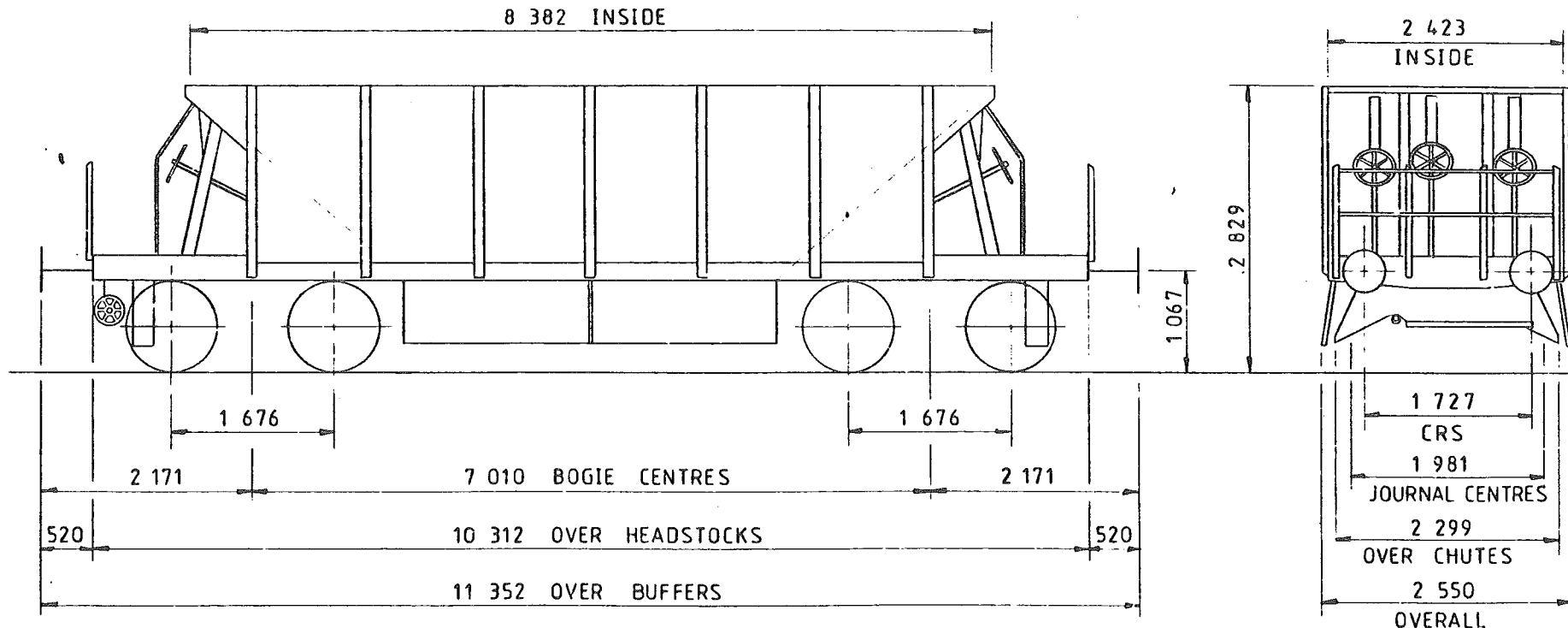

TARE -	22 200 kg
CAPACITY, WEIGHT -	40 500 kg
CAPACITY, VOLUME -	26.6 m ³
MIN CURVE -	61 m SINGLY & CLOSE COUPLED
GEN ARRGT DRG NO. -	F-S-1594
BOGIE DRG. NO. -	GLOUCESTER RC & W 2085

BRAKE -	AIR & VACUUM (A.F.I.) BLOCK & HAND SCREW
SUSPENSION -	SECONDARY COIL
COUPLINGS -	INSTANTER
BUFFERS -	PNEUMATIC, 457 DIA. HEADS
WHEELS -	952 DIA.
JOURNALS -	5 ³ / ₁₆ " ROLLER BEARINGS

ISSUE 1

EX BR DIAGRAM 590

BALLAST HOPPER - 'WALRUS'

YG 500C

LOT NUMBER	
2411	

TOPS INFORMATION						
AARKND	OPERATING	OPERATING SPEED		BRAKE FORCE DATA		EXCESS LENGTH
CARKND	PANEL NO	50 mile/h UP TO	62 tonne GLW	9 t FORCE UP TO	62 tonne GLW	
Y G V C	0 1 4 4	mile/h ABOVE		t FORCE ABOVE		

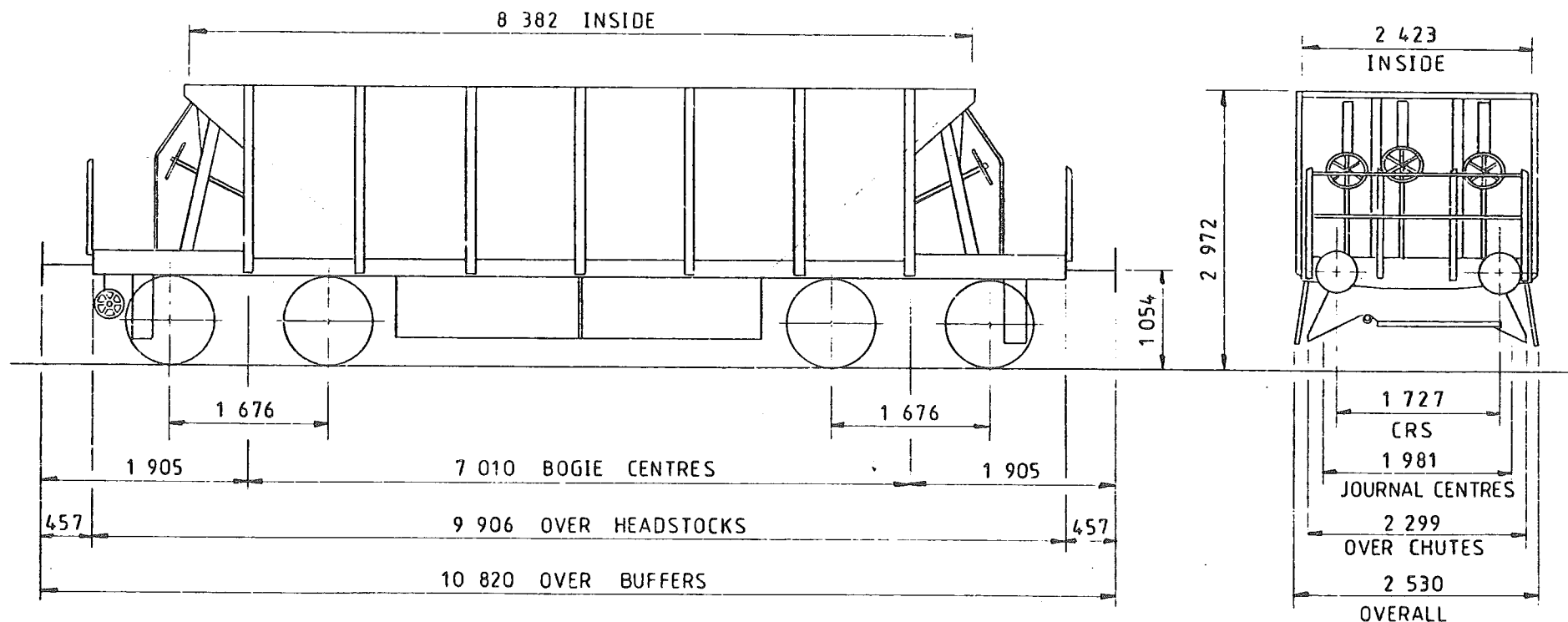

TARE -	20 750 kg
CAPACITY, WEIGHT -	40 500 kg
CAPACITY, VOLUME -	22.7 m ³
MIN CURVE -	61 m SINGLY & CLOSE COUPLED
GEN APPT DRG N -	SW-ES-73
BOGIE -	SW-SW-66

BRAKE -	VACUUM BLOCK & HAND SCREW
SUSPENSION -	SECONDARY COIL
COUPLINGS -	INSTANTER
BUFFERS -	SELF CONTAINED 305 DIA. HEAD
WHEELS -	952 DIA.
JOURNALS -	254 x 127 PLAIN BEARINGS

ISSUE 1

EX BR DIAGRAM 585

BALLAST HOPPER - 'WALRUS'

YG 500 F

LOT NUMBER	

TOPS INFORMATION					
AARKND	OPERATING	OPERATING SPEED		BRAKE FORCE DATA	EXCESS LENGTH
CARKND	PANEL No	50 mile/h UP TO		8 t FORCE UP TO	
Y G V C	8 7 8 8	mile/h ABOVE 59 tonne GLw		t FORCE ABOVE 59 tonne GLw	

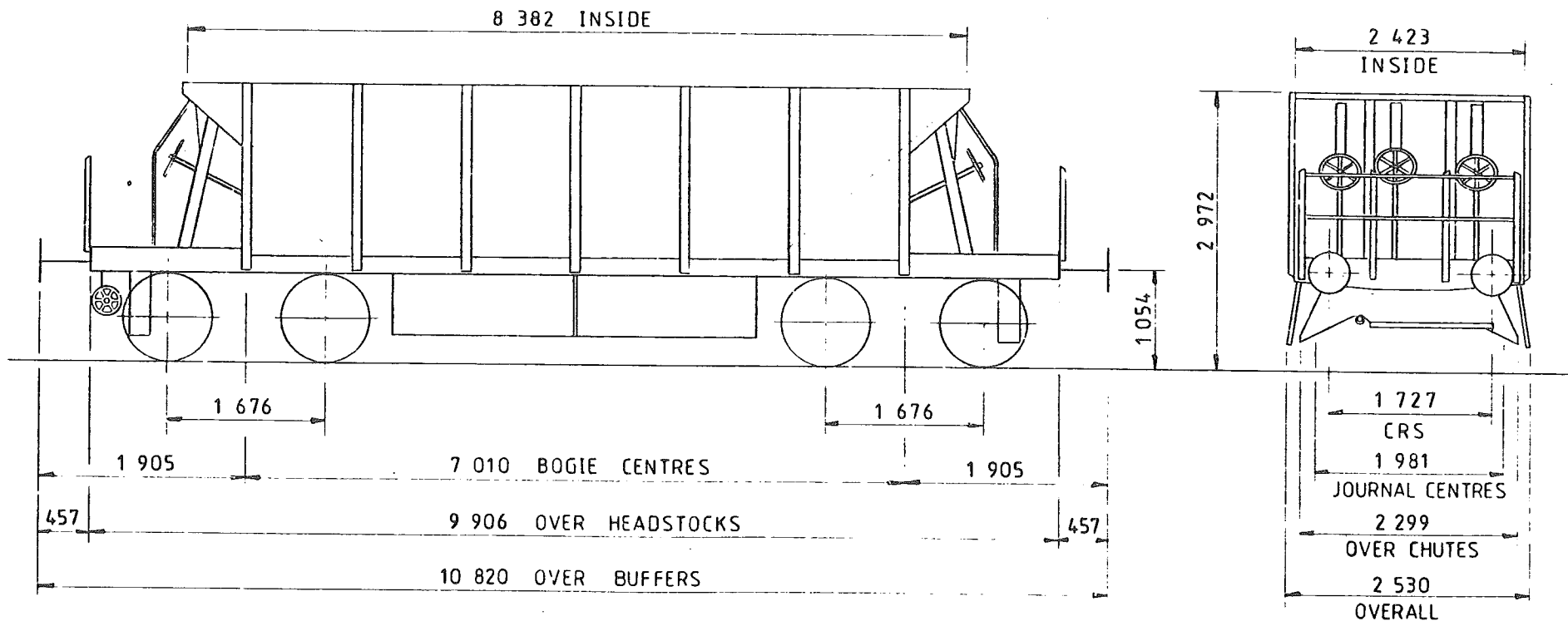

TARE	17 800 kg
CAPACITY WEIGHT	40 500 kg
CAPACITY VOLUME	22.7 m ³
MIN. CURVE	61m SINGLY & CLOSE COUPLED
WAGON NO.	E 37433
BOGIE	E 36273

BRAKE	VACUUM BLOCK & HAND SCREW
SUBSTITUTION	SECONDARY COIL
CONTROL	INSTANTER
HEAD	SELF CONTAINED, 305 DIA. HEAD
WHEEL	952 DIA.
BEARING	254 x 127 PLAIN BEARINGS

FIGURE 1

BR DIAGRAM S1775

BALLAST HOPPER - SEALION

YG 500 G

LOT NUMBER	
3802	

TOPS INFORMATION				
AARKND	OPERATING	OPERATING SPEED		EXCESS LENGTH
CARKND	PANEL NO	60 mile h UP TO	63 tonne GLW	11 t FORCE UP TO
Y G H B	0 2 5 7	mile h ABOVE		32 t FORCE ABOVE 37.5 tonne GLW

AUTOMATIC CHANGEOVER DEVICE

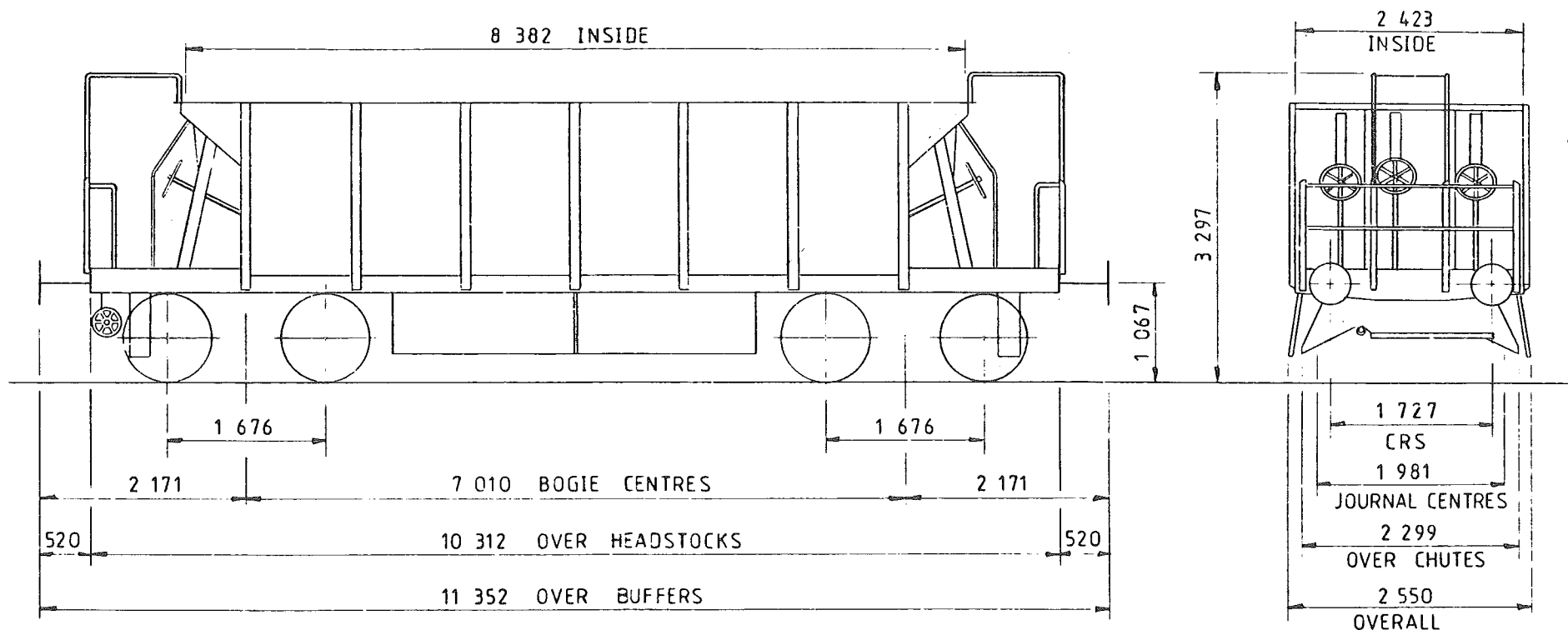

TARE -	22 250 kg
CAPACITY, WEIGHT -	40 500 kg
CAPACITY, VOLUME -	26.6 m ³
MIN CURVE -	61 m SINGLY & CLOSE COUPLED
EN APPRGT DRG N - F.S-1594	
BOGIE - GLOUCESTER RC & W DRG. NO. 2085	

BRAKE - AIR & VACUUM (A.F.I.) BLOCK & HAND SCREW
SUSPENSION - SECONDARY COIL
COUPLINGS - INSTANTER
BUFFERS - PNEUMATIC, 457 DIA. HEADS
WHEELS - 952 DIA.
JOURNALS - 5 ³ / ₁₆ " ROLLER BEARINGS

ISSUE 1

EX BR DIAGRAM 590

BALLAST HOPPER - 'SEACOW'

YG 500 H

LOT NUMBER	
3966	
4010	

TOPS INFORMATION											
AARKND		OPERATING		OPERATING SPEED				BRAKE FORCE DATA		EXCESS LENGTH	
CARKND		PANEL NO.		60 mile/h UP TO				11 t FORCE UP TO			
Y	G	B	A	0	2	5	8	62 tonne GLW			
60 mile/h ABOVE 62 tonne GLW 31 t FORCE ABOVE 62 tonne GLW											

AUTOMATIC CHANGEOVER DEVICE

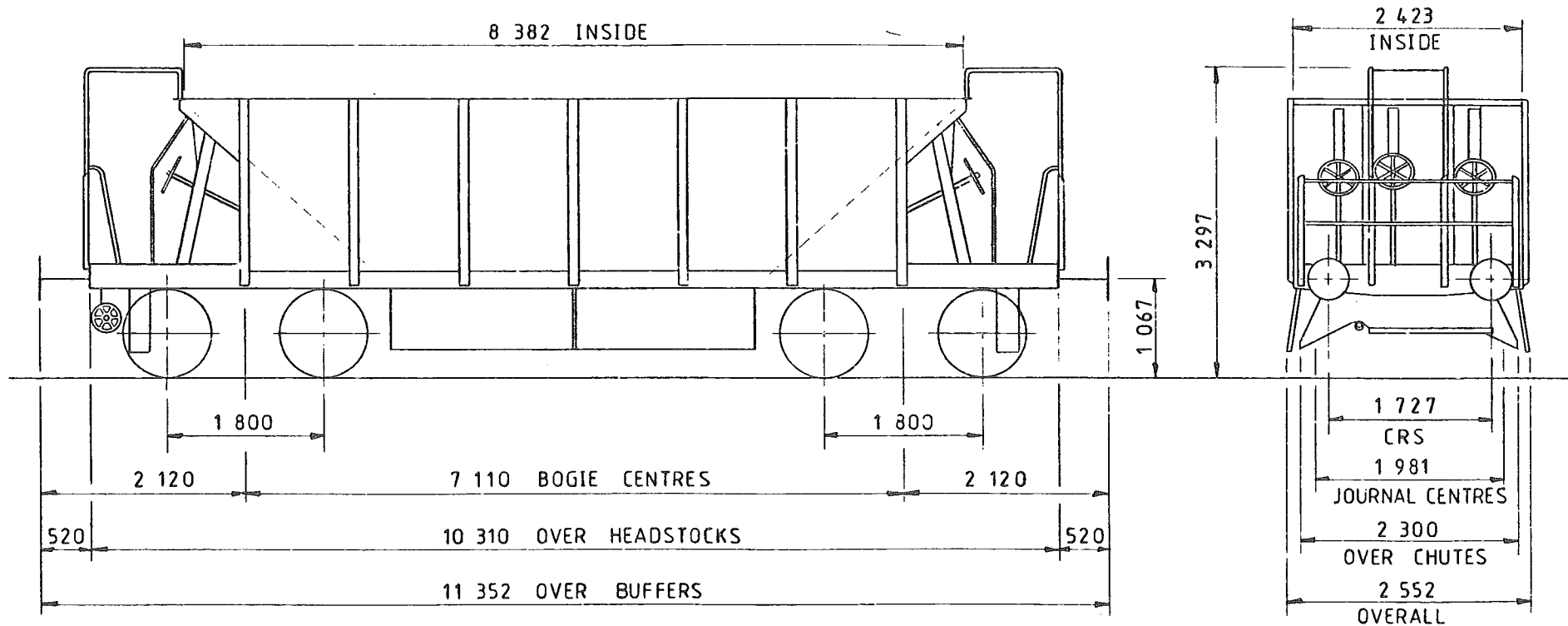

TARE -	21 000 kg
CAPACITY, WEIGHT -	41 000 kg
CAPACITY, VOLUME -	26.6 m ³
MIN. CURVE -	61m SINGLY & CLOSE COUPLED
GEN ARRGT. DRG NO. -	F-S-18801

BRAKE -	AIR BLOCK, VACUUM PIPE & HAND SCREW
SUSPENSION -	PRIMARY COIL, Y 27Cs BOGIE
COUPLINGS -	INSTANTER
BUFFERS -	HYDRAULIC, 457 DIA. HEADS
WHEELS -	920 DIA.
JOURNALS -	130 DIA. ROLLER BEARINGS

ISSUE 1

BALLAST HOPPER - 'WHALE'

YH 500 A

LOT NUMBER	
3591	

TOPS INFORMATION									
AARKND		OPERATING		OPERATING SPEED		BRAKE FORCE DATA		EXCESS LENGTH 1	
CARKND		PANEL NO.		50 mile/h UP TO		14 t FORCE UP TO			
Y	H	A	A	0	3	4	1		76 tonne GLW
								mile/h ABOVE	t FORCE ABOVE

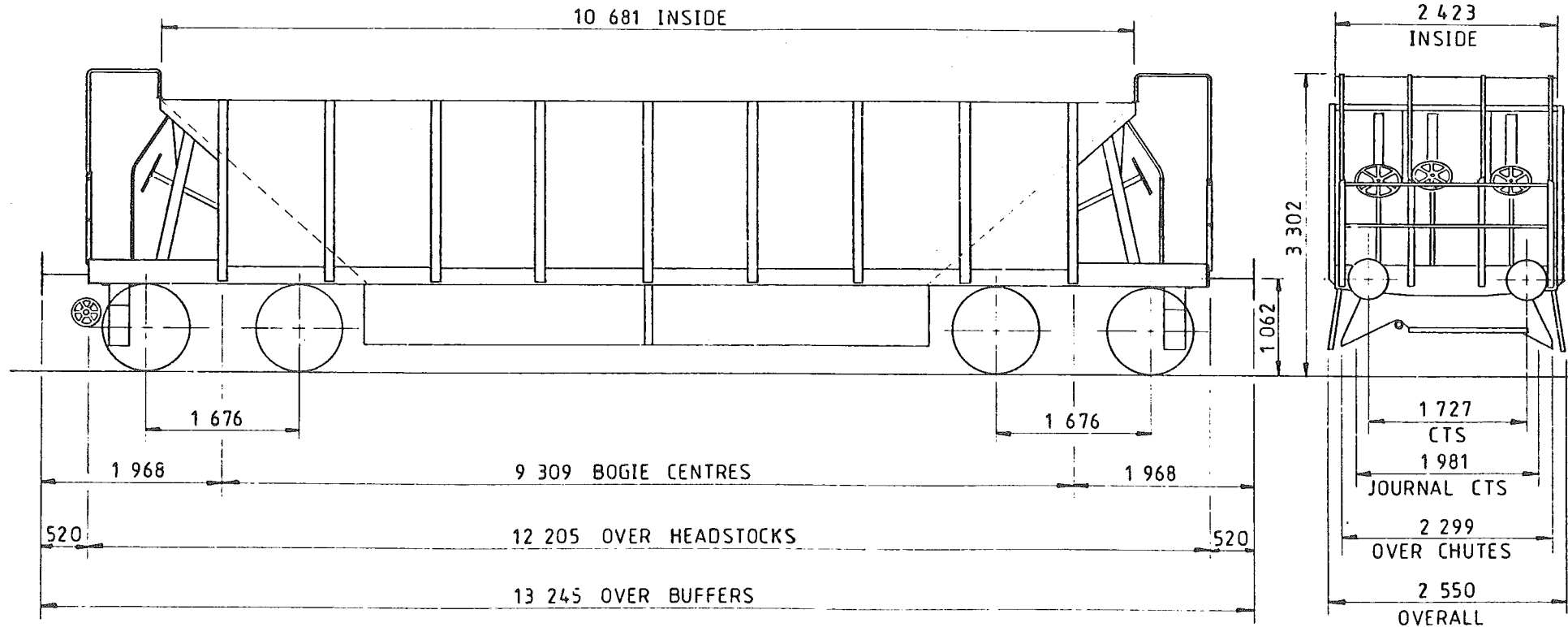

TARE -	23 900 kg
CAPACITY, WEIGHT -	51 000 kg
CAPACITY, VOLUME -	36,0 m ³
MIN. CURVE -	60 m SINGLY & CLOSE COUPLED
GEN ARRGT. DRG. N ^o - DN 833015	
BOGIE - SW-SW-1073	

BRAKE -	AIR BLOCK & HAND SCREW
SUSPENSION -	SECONDARY COIL
COUPLINGS -	INSTANTER
BUFFERS -	SELF CONTAINED 330 DIA. HEADS
WHEELS -	952 DIA.
JOURNALS -	140 (5 1/2) DIA. ROLLER BEARINGS

ISSUE 1

EX. BR. DIAGRAM 589

BALLAST HOPPER - 'WHALE'

YH 500 B

LOT NUMBER	
3591	

TOPS INFORMATION						
AARKND	OPERATING		OPERATING SPEED		BRAKE FORCE DATA	EXCESS LENGTH 1
CARKND	PANEL NO.		50 mile/h UP TO	14 t FORCE UP TO	76 tonne GLW	
Y H A A	0	3 4 1	mile/h ABOVE	t FORCE ABOVE		

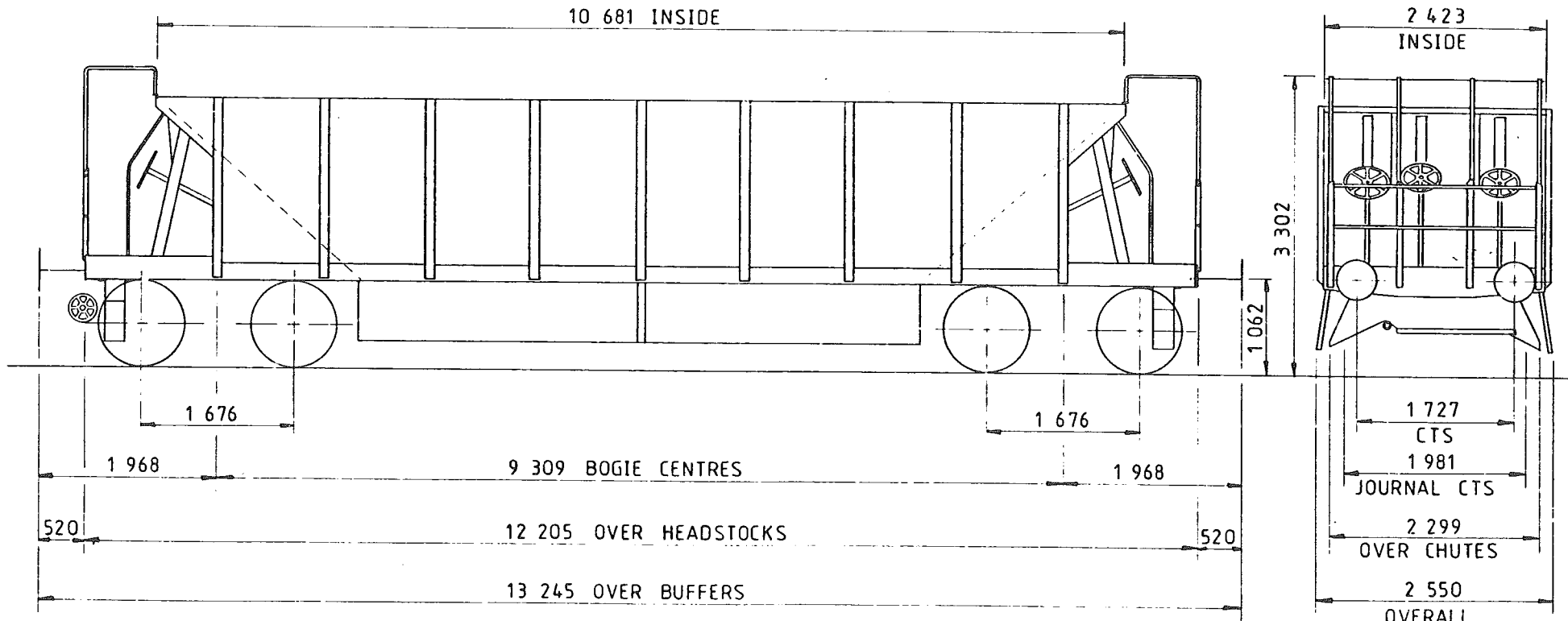

TARE -	23 900 kg
CAPACITY, WEIGHT -	51 000 kg
CAPACITY, VOLUME -	36,0 m ³
MIN. CURVE -	60 m SINGLY & CLOSE COUPLED
GEN ARRGT. DRG NO. -	DN 833015
	BOGIE - SW-SW-1073

BRAKE -	AIR BLOCK & HAND SCREW
SUSPENSION -	SECONDARY COIL
COUPLINGS -	INSTANTER
BUFFERS -	SELF CONTAINED 330 DIA. HEADS
WHEELS -	952 DIA.
JOURNALS -	140 (5 1/2) DIA. ROLLER BEARINGS

ISSUE 1

EX. BR DIAGRAM 589

TRACKLAYER

YJ 009 D

LOT NUMBER	

TOPS INFORMATION										
AARKND		OPERATING		OPERATING SPEED				BRAKE FORCE DATA		EXCESS LENGTH
CARKND		PANEL NO		35 mile/h UP TO 81 tonne GLW				13 t FORCE UP TO 81 tonne GLW		
Y	J	V	B	8	9	3	2	35 mile/h ABOVE		13 t FORCE ABOVE

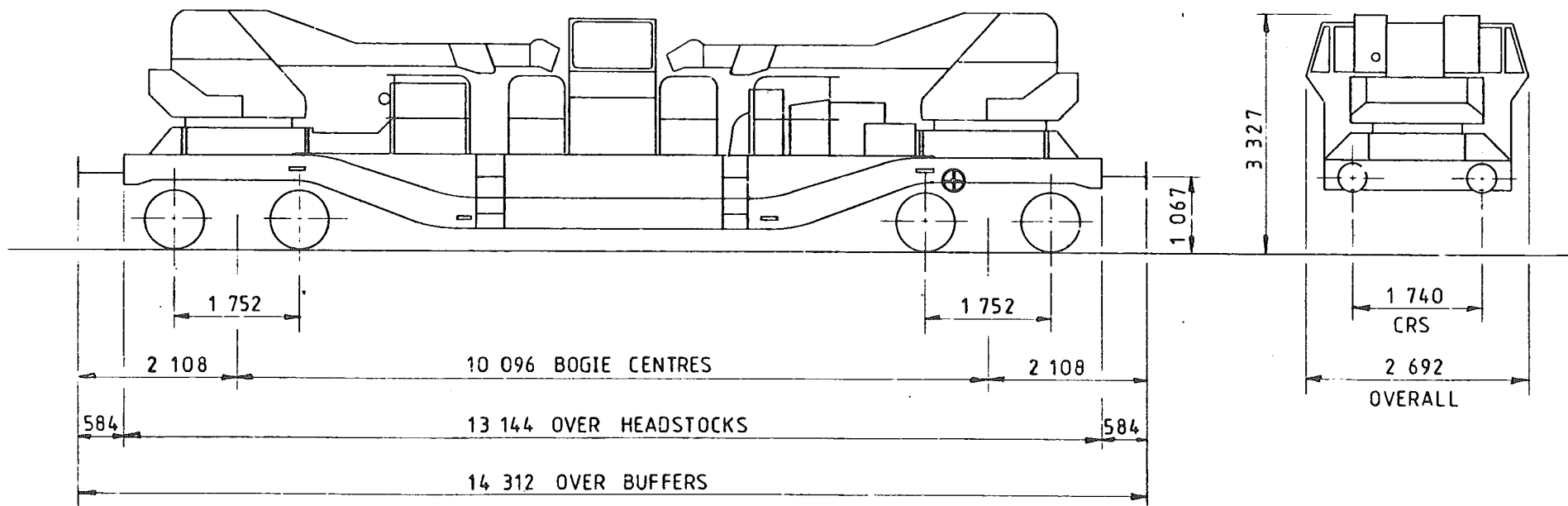

TARE -	81 500 kg
CAPACITY, WEIGHT -	13 000 kg
CAPACITY, VOLUME -	
MIN CURVE -	53m
GEN ARRGT. DRG N. -	PS-A0-2022

BRAKE -	VACUUM BLOCK & HAND SCREW
SUSPENSION -	SECONDARY COIL, (DIAMOND FRAME BOGIE)
COUPLINGS -	BR SCREW
BUFFERS -	HYDRAULIC, 406 DIA. HEADS
WHEELS -	838 DIA.
JOURNALS -	280x140, (11'x5 1/2') PLAIN BEARINGS

ISSUE 1

EX BR DIAGRAM Z 018

TRACKLAYER

YJ 009 F

LOT NUMBER	

TOPS INFORMATION										
AARKND		OPERATING		OPERATING SPEED				BRAKE FORCE DATA		EXCESS LENGTH
CARKND		PANEL NO.		35 mile/h UP TO		13 + FORCE UP TO				
Y	J	V	B	8	9	3	2	+ FORCE ABOVE 81 tonne GLW		
				mile/h ABOVE						

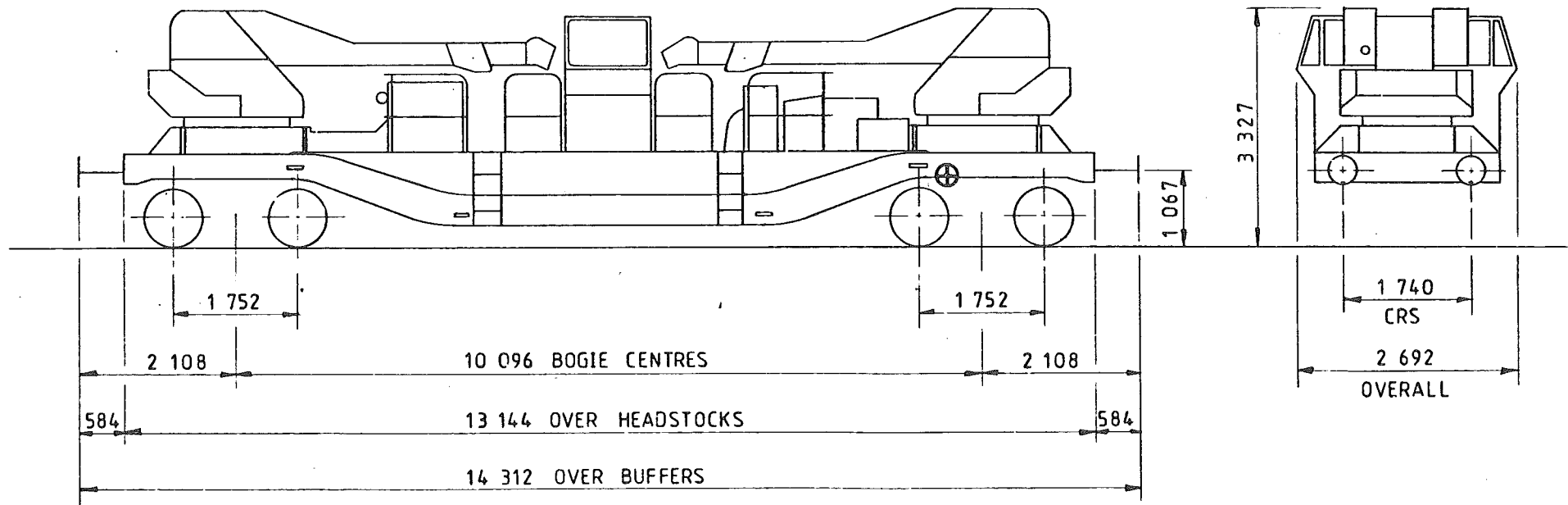

TARE -	81 500 kg
CAPACITY, WEIGHT -	13 000 kg
CAPACITY, VOLUME -	—
MIN. CURVE -	53m
GEN ARRGT. DRG NO. -	PS-A0-2022

BRAKE -	VACUUM BLOCK & HAND SCREW
SUSPENSION -	SECONDARY COIL, (DIAMOND FRAME BOGIE)
COUPLINGS -	BR SCREW
BUFFERS -	HYDRAULIC, 406 DIA. HEADS
WHEELS -	838 DIA.
JOURNALS -	280x140, (11x5 1/2) PLAIN BEARINGS

ISSUE 1 -

EX BR DIAGRAM Z 018

TRACKLAYER

YJ 009 G

LOT NUMBER	

TOPS INFORMATION											
AARKND		OPERATING		OPERATING SPEED				BRAKE FORCE DATA		EXCESS LENGTH	
CARKND		PANEL NO.		35 mile/h UP TO		13 t FORCE UP TO					
Y	J	V	B	8	9	3	2	mile/h ABOVE 81 tonne GLW			t FORCE ABOVE 81 tonne GLW

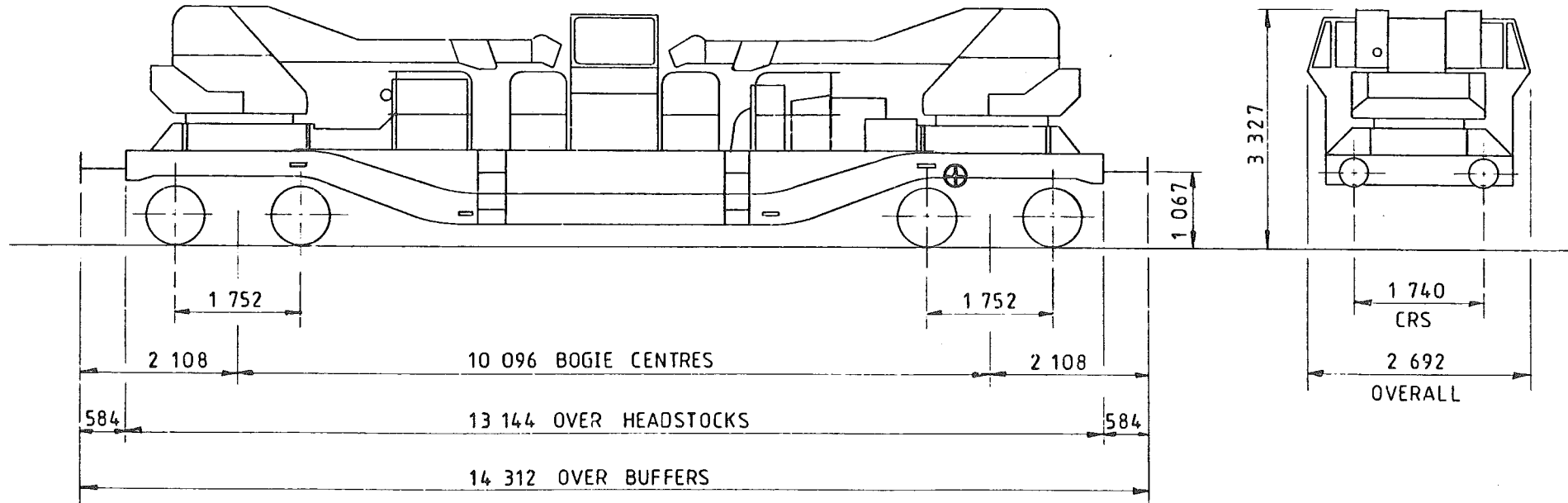

TARE -	81 500 kg
CAPACITY, WEIGHT -	13 000 kg
CAPACITY, VOLUME -	—
MIN. CURVE -	53m
GEN ARRGT. DRG NO. -	PS-A0-2022

BRAKE -	VACUUM BLOCK & HAND SCREW
SUSPENSION -	SECONDARY LOIL, (DIAMOND FRAME BOGIE)
COUPLINGS -	BR SCREW
BUFFERS -	HYDRAULIC, 406 DIA. HEADS
WHEELS -	838 DIA.
JOURNALS -	280x140, (11'x 5 1/2') PLAIN BEARINGS

ISSUE 1

EX BR DIAGRAM Z 018

TRACKLAYER

YJ 009 I

LOT NUMBER	

TOPS INFORMATION															
AARKND		OPERATING			OPERATING SPEED			BRAKE FORCE DATA			EXCESS LENGTH				
CARKND		PANEL NO.			45 mile/h UP TO			14 t FORCE UP TO			0				
Y	J	V	B	8	7	7	1	mile/h ABOVE	85	tonne	GLW	↑ FORCE ABOVE	85	tonne	GLW

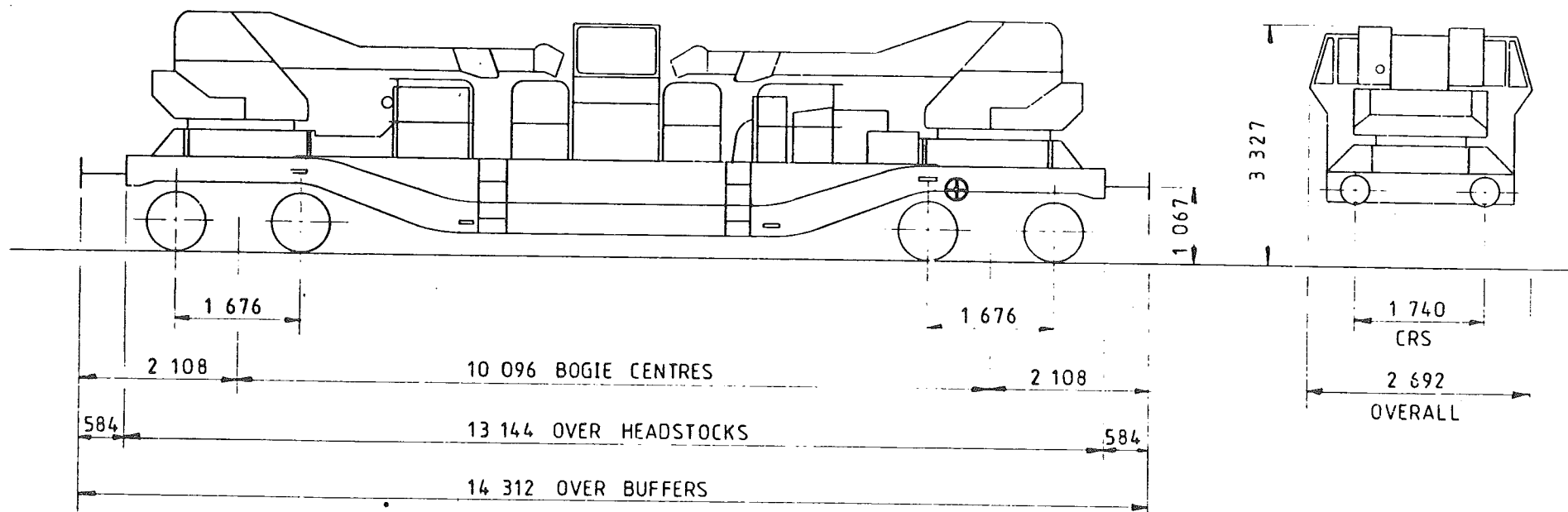

TARE -	85 000 kg
CAPACITY WEIGHT -	13 000 kg
CAPACITY VOLUME -	—
MIN CURVE -	53m
GEN APPG DESIGN	PS-AG-2022

BRAKE -	VACUUM BLOCK & HAND SCREW
SUSPENSION -	SECONDARY COIL, (GLOUCESTER BOGIE)
COUPLINGS -	BR SCREW
BUFFERS -	HYDRAULIC, 406 DIA HEADS
WHEELS -	838 DIA
JOURNALS -	140, (5½") DIA. ROLLER BEARINGS

ISSUE 1

EX BR DIAGRAM Z 018

TRACKLAYER

YJ 009J

LOT NUMBER	

TOPS INFORMATION							
AARKND	OPERATING		OPERATING SPEED		BRAKE FORCE DATA		EXCESS LENGTH 0
CARKND	PANEL NO.		45 mile/h UP TO		7↑ FORCE UP TO		
Y J W B	8 5 1 4	mile/h ABOVE		82 tonne GLW		↑ FORCE ABOVE	

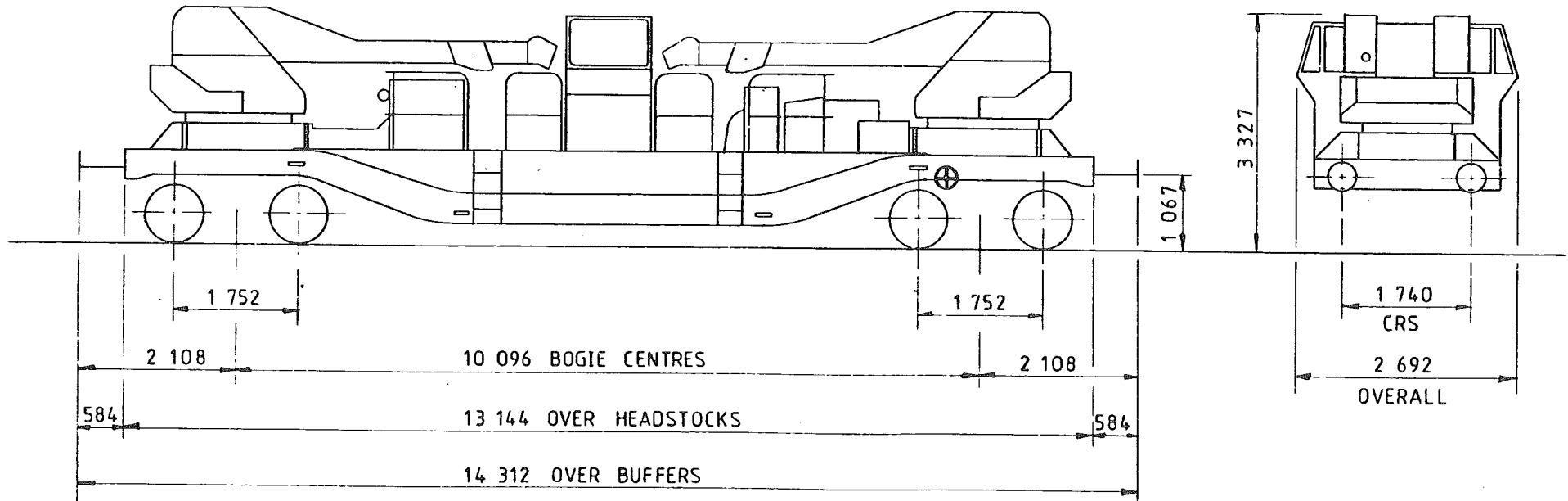

TARE -	82 000 kg
CAPACITY, WEIGHT -	13 000 kg
CAPACITY, VOLUME -	—
MIN. CURVE -	53m
GEN. ARRGT. DRG. NO. -	PS-A0-2022

BRAKE -	VACUUM BLOCK, AIR PIPE & HAND SCREW
SUSPENSION -	SECONDARY COIL, (DIAMOND FRAME BOGIE)
COUPLINGS -	BR SCREW
BUFFERS -	HYDRAULIC, 406 DIA. HEADS
WHEELS -	838 DIA.
JOURNALS -	280 x 140, (11 x 5 1/2) PLAIN BEARINGS

ISSUE 1

EX BR DIAGRAM U 216

TRACKLAYER

YJ 009L

LOT NUMBER	

TOPS INFORMATION										
AARKND		OPERATING		OPERATING SPEED				BRAKE FORCE DATA		EXCESS LENGTH
CARKND		PANEL NO		60 mile/h UP TO				6 t FORCE UP TO		
Y J V B		8 8 5 3		mile/h ABOVE				81 tonne GLW		

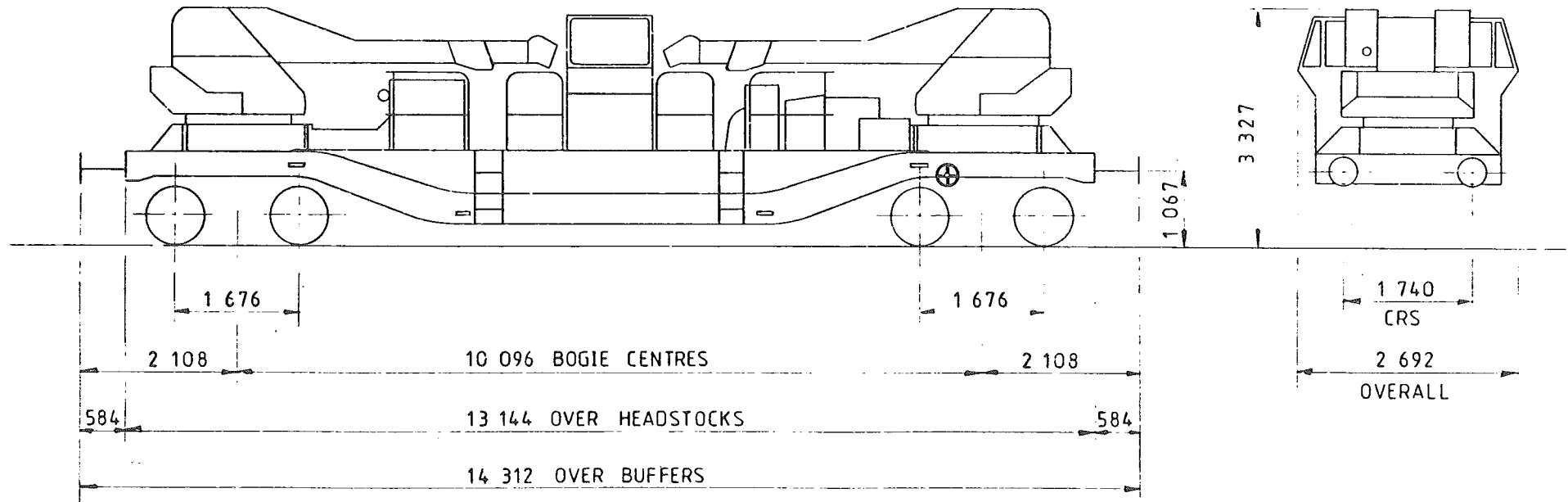

TARE -	81 750 kg
CAPACITY WEIGHT -	13 000 kg
CAPACITY / VOLUME -	
MIN CURVE -	53m
	PS-A0-2022

BRAKE -	VACUUM BLOCK & HAND SCREW
SUSPENSION -	SECONDARY COIL, (GLOUCESTER BOGIE)
COUPLINGS -	BR SCREW
BUFFERS -	HYDRAULIC, 406 DIA HEADS
	838 DIA
	140, (5½") DIA. ROLLER BEARINGS

ISSUE 1 -

EX BR DIAGRAM Z 110

TRACKLAYER

YJ 010 A

LOT NUMBER	

TOPS INFORMATION										
AARKND		OPERATING		OPERATING SPEED				BRAKE FORCE DATA		EXCESS LENGTH
CARKND		PANEL NO.		35 mile/h UP TO				13 t FORCE UP TO		
Y	J	V	B	8	9	3	2	81 tonne GLW		
								+ FORCE ABOVE		
								81 tonne GLW		

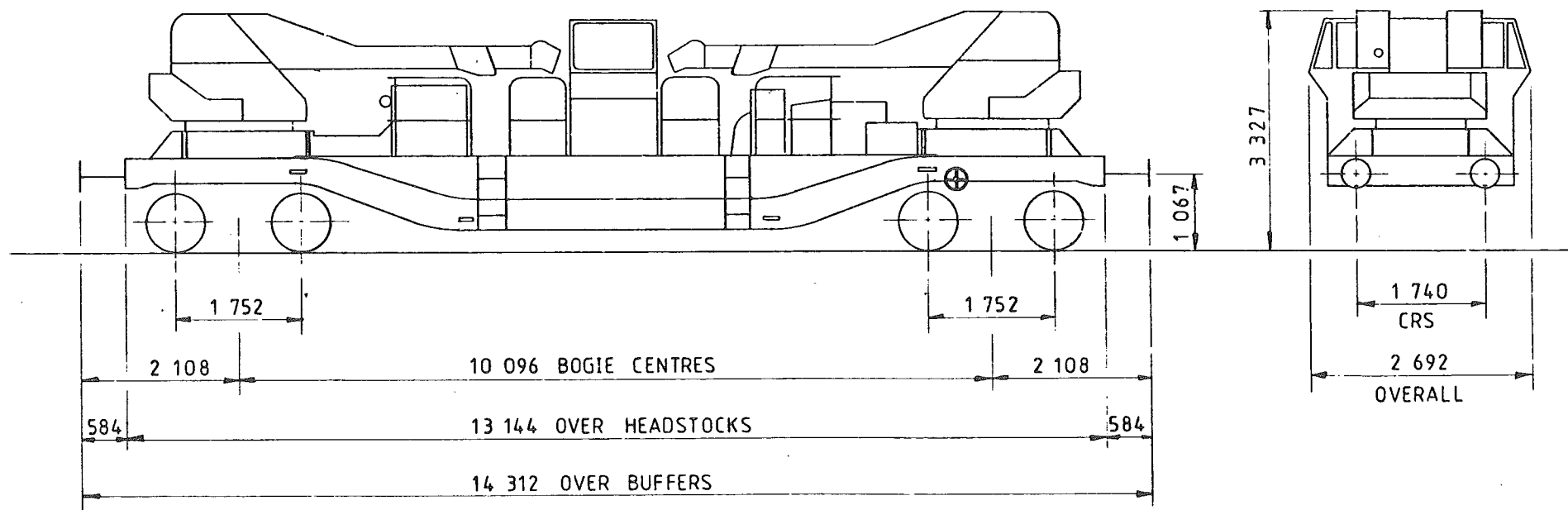

TARE -	81 500 kg
CAPACITY, WEIGHT -	13 000 kg
CAPACITY, VOLUME -	
MIN. CURVE -	53m
GEN ARRGT. DRG NO. -	PS-A0-2022

BRAKE -	VACUUM BLOCK & HAND SCREW
SUSPENSION -	SECONDARY COIL, (DIAMOND FRAME BOGIE)
COUPLINGS -	BR SCREW
BUFFERS -	HYDRAULIC, 406 DIA. HEADS
WHEELS -	838 DIA.
JOURNALS -	280x140, (11"x5 1/2") PLAIN BEARINGS

ISSUE 1 -

EX BR DIAGRAM Z 018

TRACKLAYER

YJ 011 A

LOT NUMBER	

TOPS INFORMATION							
AARKND	OPERATING		OPERATING SPEED		BRAKE FORCE DATA		EXCESS LENGTH
CARKND	PANEL NO.		35 mile/h UP TO		5 t FORCE UP TO		
Y J V T	8 6 3 5	71 tonne GLW		t FORCE ABOVE 71 tonne GLW			

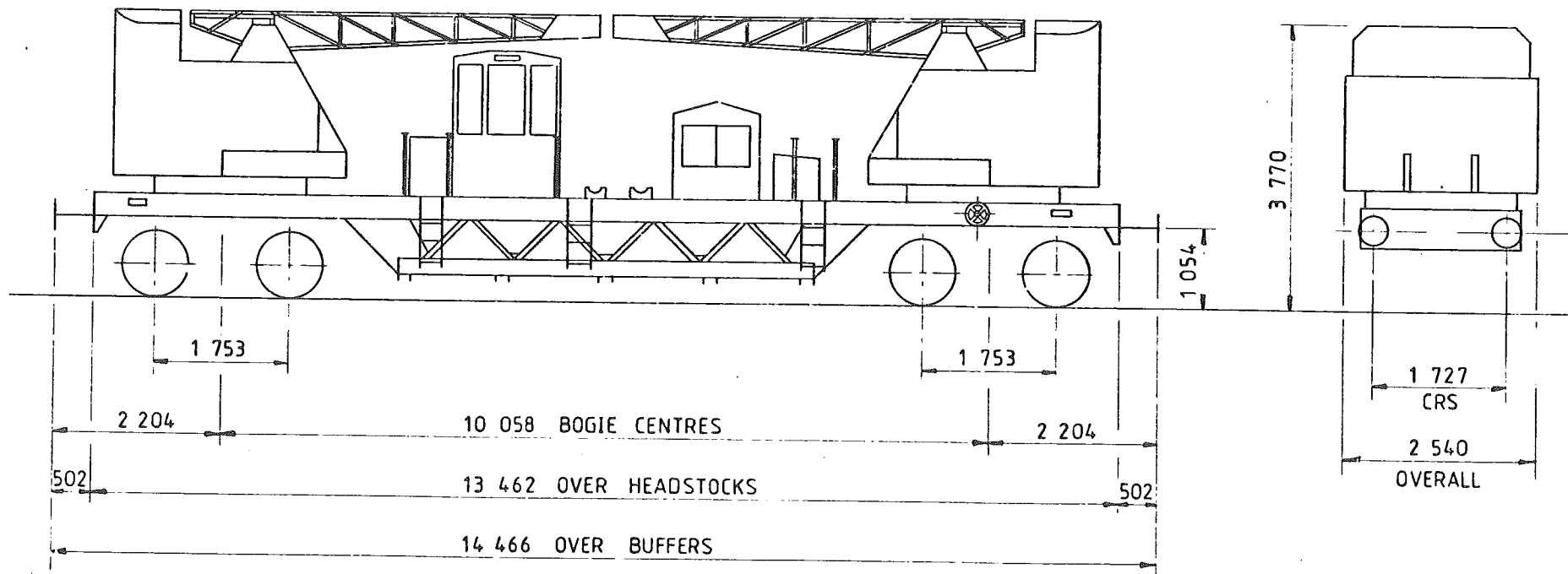

TARE -	71 900 kg
CAPACITY, WEIGHT -	12 200 kg
CAPACITY, VOLUME -	---
MIN. CURVE -	55 m
GEN. ARRGT. DRG N ^o -	

BRAKE -	VACUUM BLOCK & HAND SCREW
SUSPENSION -	EYEBOLT & LINK
COUPLINGS -	BR SCREW
BUFFERS -	HYDRAULIC, 394 DIA. HEADS
WHEELS -	876 DIA.
JOURNALS -	254 x 127 PLAIN BEARINGS

ISSUE 1

EX. BR. DIAGRAM U209

TRACKLAYER

YJ 015 A

LOT NUMBER	

TOPS INFORMATION						
AARKND	OPERATING		OPERATING SPEED		BRAKE FORCE DATA	EXCESS LENGTH
CARKND	PANEL NO.		45 mile/h UP TO		5 t FORCE UP TO	
Y J V T	8 6 4 6	mile/h ABOVE		78 tonne GLW	78 tonne GLW	

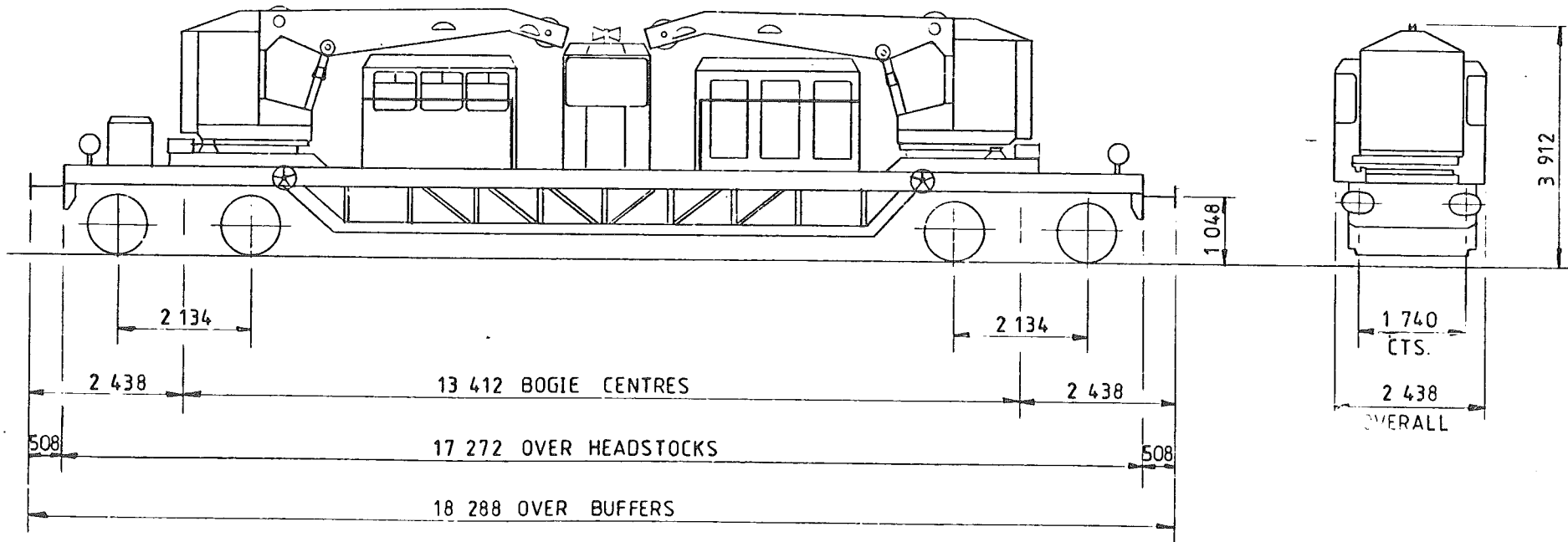

TARE -	78 000 kg
CAPACITY, WEIGHT -	11 100 kg
CAPACITY, VOLUME -	—
MIN CURVE -	—
GEN. ARRGT. DRG. NO. -	TAYLOR & HUBBARD DRG. NO. 3960

BRAKE -	VACUUM BLOCK & HAND SCREW
SUSPENSION -	EYE BOLT & LINK
COUPLINGS -	BR SCREW
BUFFERS -	SELF CONTAINED, 508 x 343 OVAL HEADS
WHEELS -	914 DIA.
JOURNALS -	140 DIA. ROLLER BEARINGS

ISSUE 1

TRACKLAYER

YJ 016 A

LOT NUMBER	

TOPS INFORMATION						
AARKND	OPERATING	OPERATING SPEED		BRAKE FORCE DATA		EXCESS LENGTH
CARKND	PANEL NO.	45 mile/h UP TO		19 t FORCE UP TO		
Y J V S	8 6 4 4	- mile/h ABOVE		+ FORCE ABOVE		
		79 tonne GLW		79 tonne GLW		

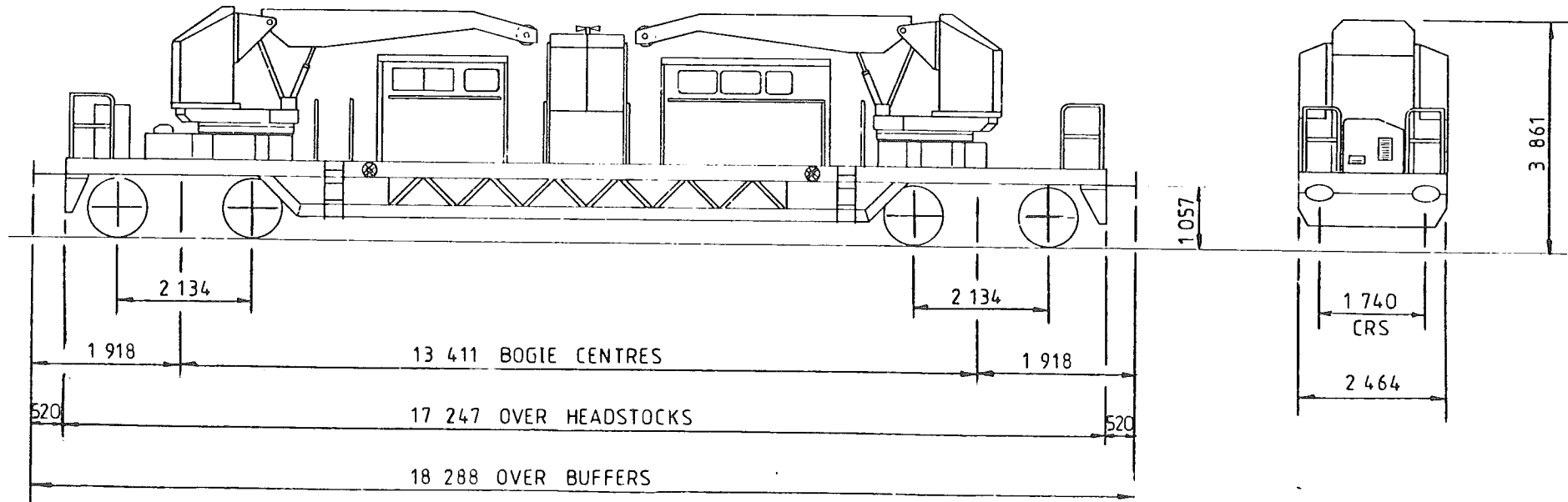

TARE -	79 000 kg
CAPACITY, WEIGHT -	11 100 kg
CAPACITY, VOLUME -	—
MIN CURVE -	—
GEN ARRGT DRG N. -	THOS SMITH DRG NO. -
	1650382

BRAKE -	VACUUM BLOCK & HAND SCREW
SUSPENSION -	SECONDARY COIL
COUPLINGS -	BR SCREW
BUFFERS -	SELF CONTAINED
WHEELS -	965 DIA.
JOURNALS -	—

TRACKLAYER

YJ 016 B

LOT NUMBER	

TOPS INFORMATION							
AARKND	OPERATING		OPERATING SPEED		BRAKE FORCE DATA		EXCESS LENGTH
CARKND	PANEL NO.		45 mile/h UP TO		11 t FORCE UP TO		
Y J V S	8	6	4	9	82 tonne GLW		
					82 tonne GLW		
					82 tonne GLW		

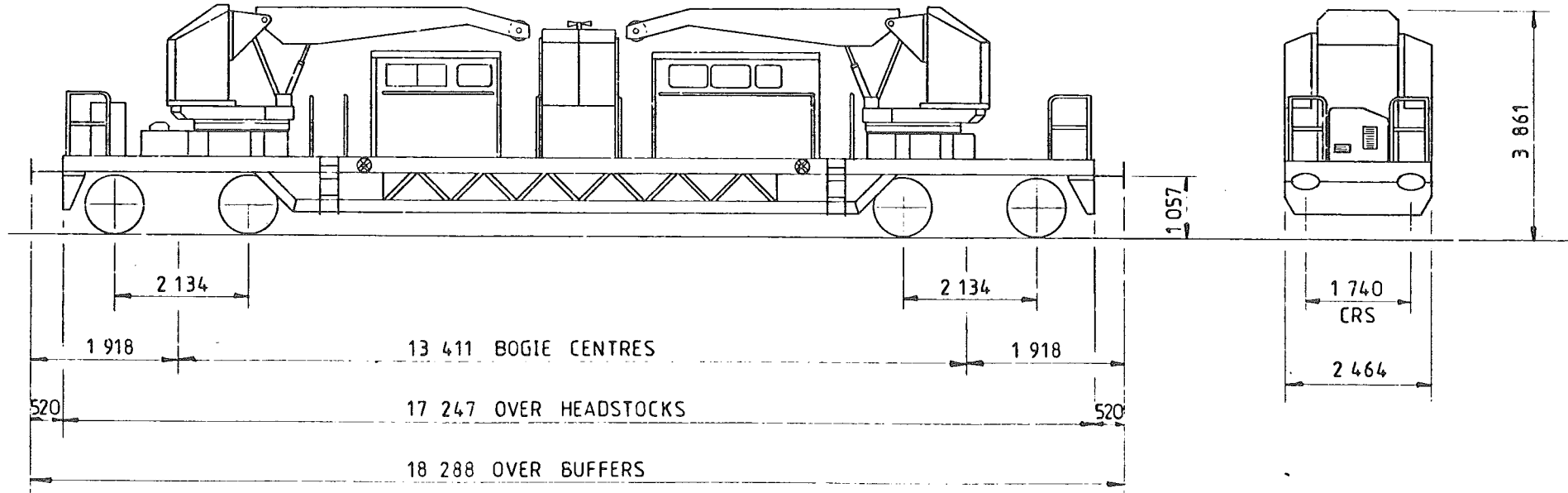

TARE -	82000 kg
CAPACITY, WEIGHT -	11100 kg
CAPACITY, VOLUME -	—
MIN. CURVE -	—
GEN. ARRGT. DRG N ^o .	THOS. SMITH DRG N ^o .
	1650382

BRAKE -	VACUUM BLOCK & HAND SCREW
SUSPENSION -	SECONDARY COIL
COUPLINGS -	BR SCREW
BUFFERS -	SELF CONTAINED
WHEELS -	965 DIA.
JOURNALS -	—

ISSUE 1

EX. BR. DIAGRAM U 218

TRACKLAYER

YJ 018 A

LOT NUMBER	

TOPS INFORMATION										
AARKND		OPERATING		OPERATING SPEED			BRAKE FORCE DATA		EXCESS LENGTH	
CARKND		PANEL NO.		40 mile/h UP TO			24t FORCE UP TO			
Y J B P		8 2 5 1		mile/h ABOVE 85 tonne GLW			+ FORCE ABOVE 85 tonne GLW			

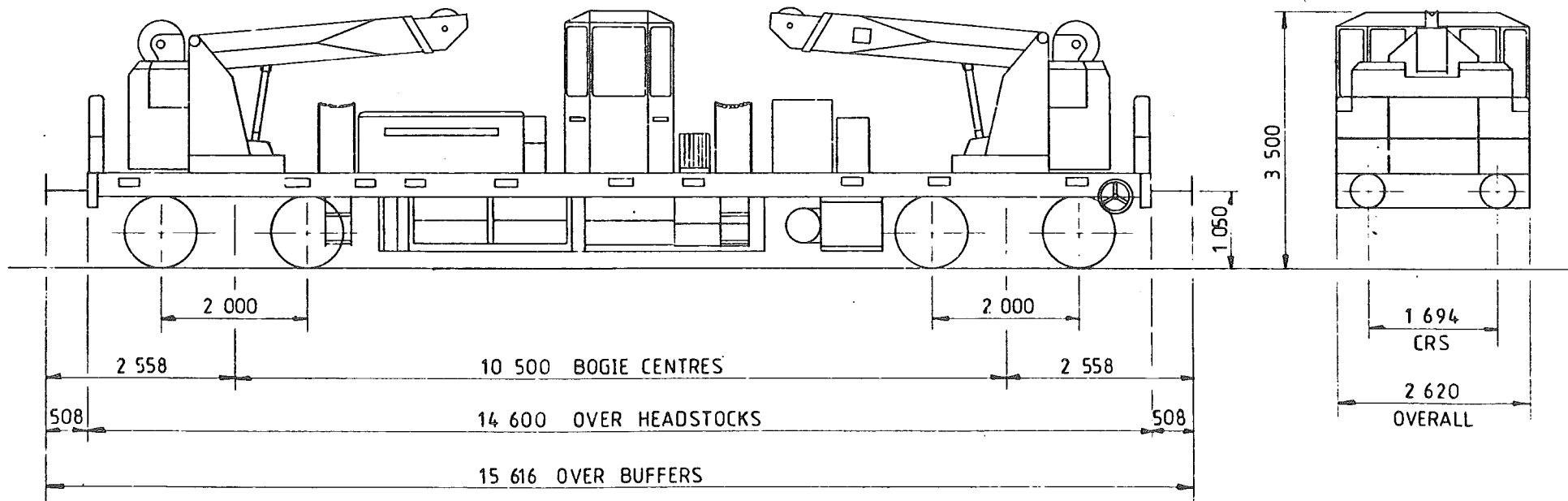

TARE -	85 000 kg
CAPACITY, WEIGHT -	12 500 kg
CAPACITY, VOLUME -	—
MIN. CURVE -	80 m
GEN. ARRGT. DRG. NO. -	—

BRAKE -	AIR BLOCK, VAC PIPE & HAND SCREW
SUSPENSION -	SECONDARY COIL
COUPLINGS -	BR SCREW
BUFFERS -	HYDRAULIC, 457 DIA. HEADS
WHEELS -	952 DIA.
JOURNALS -	150 DIA. ROLLER BEARINGS

ISSUE 1

12.5 TONNE TWIN JIB TRACKLAYER

YJ 019 A

LOT NUMBER	

TOPS INFORMATION													
AARKND		OPERATING		OPERATING SPEED				BRAKE FORCE DATA		EXCESS LENGTH			
CARKND		PANEL NO.		45 mile/h UP TO				24t FORCE UP TO					
Y	J	B	C	8	3	5	6	mile/h ABOVE 87 tonne GLW				FORCE ABOVE 87 tonne GLW	

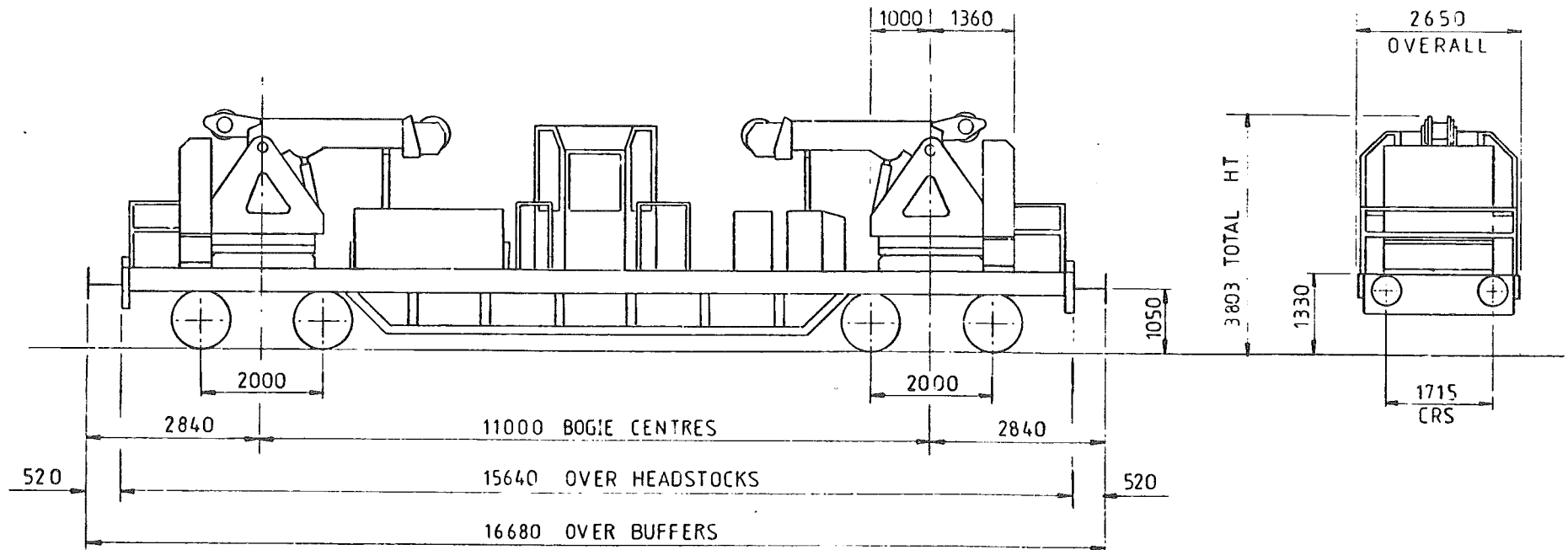

TARE -	86 ⁰⁰ Kg
CAPACITY, WEIGHT -	125 ⁰⁰ Kg
CAPACITY, VOLUME -	—
MIN. CURVE -	80 m
GEN. ARRGT. DRG N ^o . -	—

BRAKE -	AIR BLOCK, VAC PIPE, HAND SCREW.
SUSPENSION -	SECONDARY COIL
COUPLINGS -	B. R. SCREW
BUFFERS -	PNEUMATIC, 457 DIA HEADS
WHEELS -	952 DIA
JOURNALS -	150 DIA ROLLER BEARINGS

ISSUE 1

EX. BR. DIAGRAM

LONG WELDED RAIL CARRIER - 'MARLIN'

YK 500 B

LOT NUMBER	
3717	

TOPS INFORMATION										
AARKND		OPERATING		OPERATING SPEED				BRAKE FORCE DATA		EXCESS LENGTH 12
CARKND		PANEL NO.		60 mile/h UP TO				16 t FORCE UP TO		
Y	K	A	B	0 2 6 0		- mile/h ABOVE		40 tonne GLW		

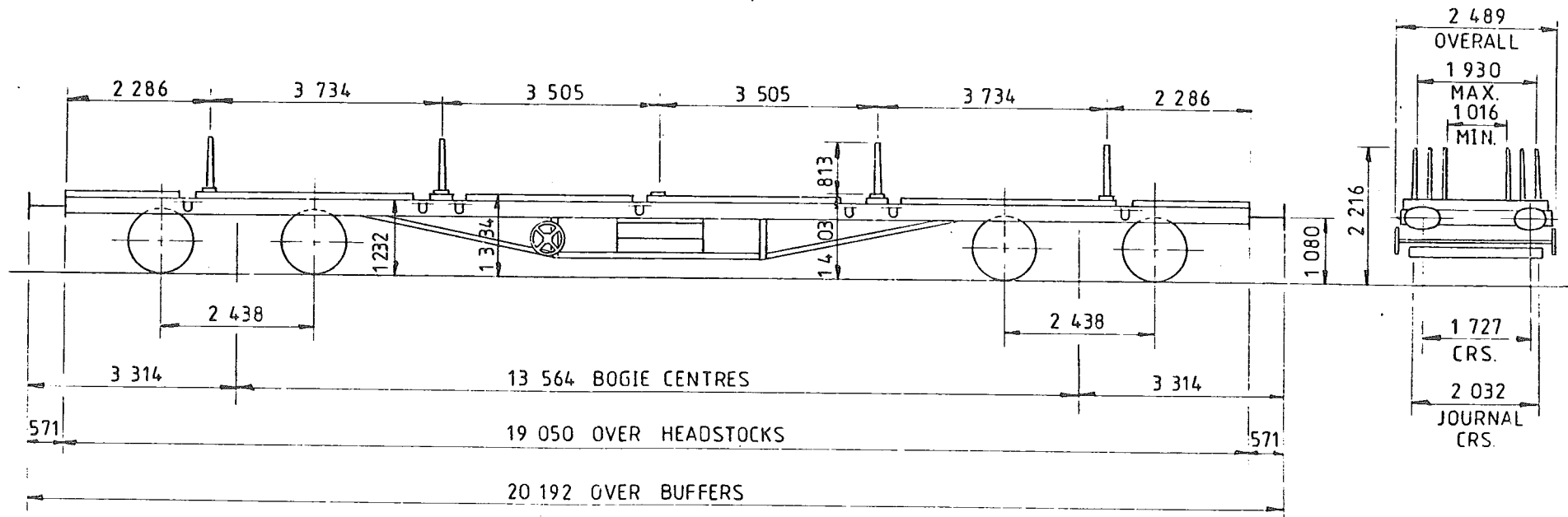

TARE -	25 950 kg
CAPACITY, WEIGHT -	14 000 kg
CAPACITY, VOLUME -	—
MIN. CURVE -	71m SINGLY & CLOSE COUPLED
GEN. ARRGT. DRG N ^o -	—

BRAKE -	AIR BLOCK & HAND SCREW
SUSPENSION -	EYE BOLT
COUPLINGS -	BR SCREW
BUFFERS -	SELF CONTAINED, 610 x 356 OVAL HEADS
WHEELS -	1 067 DIA
JOURNALS -	228 x 114, (9 x 4 1/2) PLAIN BEARINGS

ISSUE 1

EX. BR DIAGRAM 656

41 TONNE BOGIE RAIL WAGON 'GANE A'

YL 002 A

LOT NUMBER	
2094	
Pt 2208	

TOPS INFORMATION					
AARKND	OPERATING	OPERATING SPEED		BRAKE FORCE DATA	
CARKND	PANEL NO.	50 mile/h UP TO		NO POWER BRAKE	
Y L O A	7 0 6 7	mile/h ABOVE 60 tonne GLW			
EXCESS LENGTH					

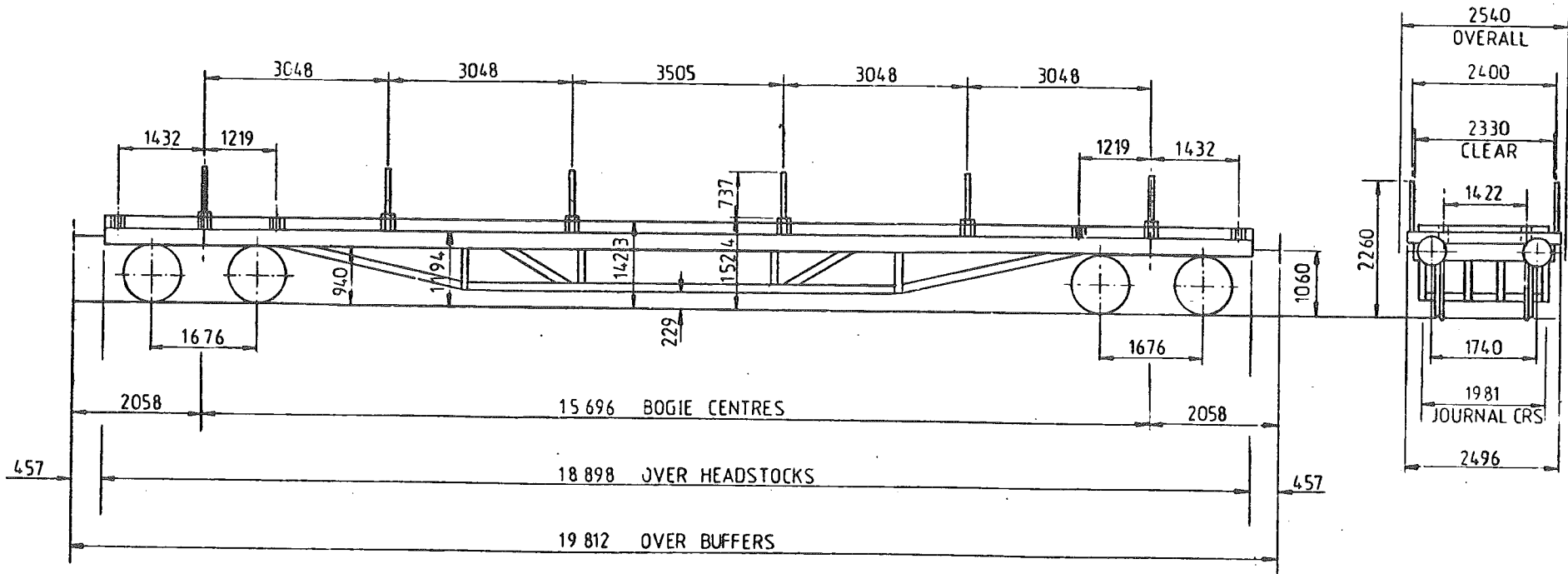

TARE -	21950 Kg
CAPACITY, WEIGHT -	40650 Kg
CAPACITY, VOLUME -	
MIN. CURVE -	41m
GEN. ARRG'T. DRG. N ^o -	108309 A
BOGIE G.A. DRG N ^o -	52161

BRAKE -	HAND LEVER
SUSPENSION -	SECONDARY COIL
COUPLINGS -	INSTANTER
BUFFERS -	HYDRAULIC 508 DIA HEADS
WHEELS -	952 DIA
JOURNALS -	254 x 127 (PLAIN BEARINGS)

ISSUE 1

EX. BR. DIAGRAM 641

41 TONNE BOGIE RAIL WAGON 'GANE A'

YL 002 B

LOT NUMBER	
Pt 2208	

TOPS INFORMATION					
AARKND	OPERATING	OPERATING SPEED		BRAKE FORCE DATA	EXCESS LENGTH
CARKND	PANEL NO.	50 mile/h UP TO		NO POWER BRAKE	
Y L P A	7 0 2 1	- mile/h ABOVE 60 tonne GLW			

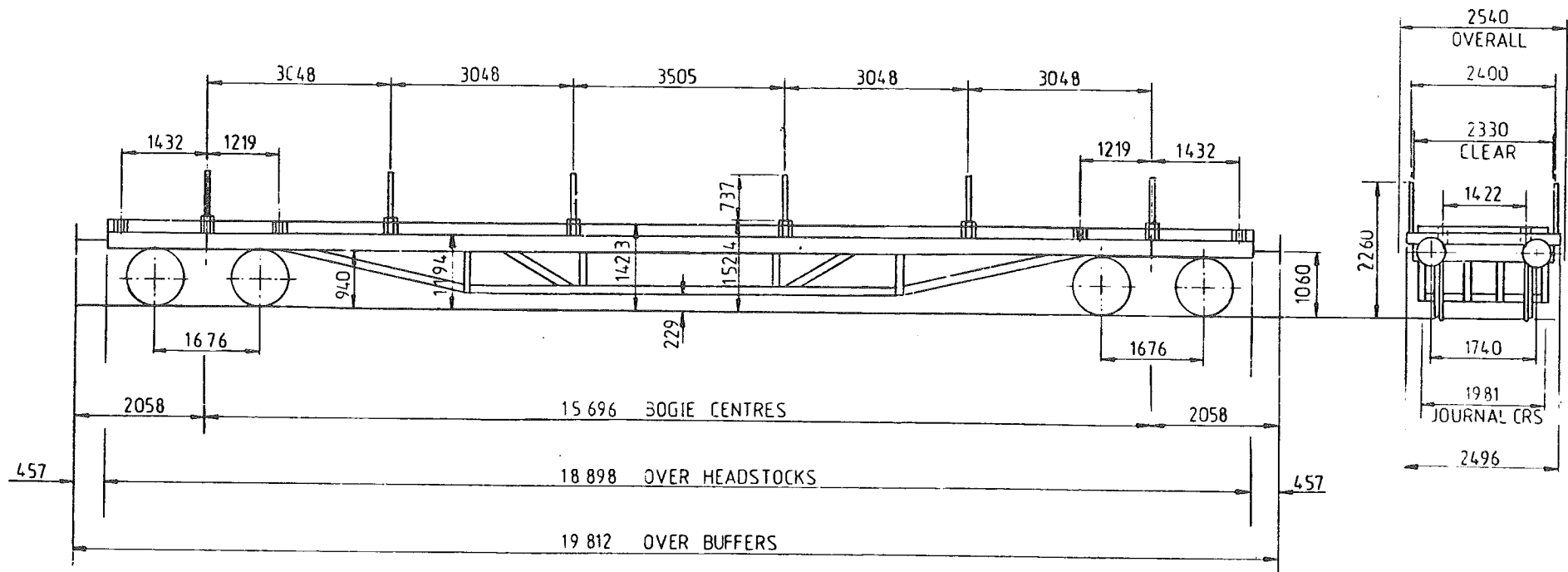

TARE -	21950 Kg
CAPACITY, WEIGHT -	40650 Kg
CAPACITY, VOLUME -	
MIN. CURVE -	41m
GEN. ARRGT. DRG. N ^o -	108309 A
BOGIE G.A. DRG. N ^o -	52161

BRAKE -	HAND LEVER & VACUUM PIPE
SUSPENSION -	SECONDARY COIL
COUPLINGS -	INSTANTER
BUFFERS -	HYDRAULIC 508 DIA HEADS
WHEELS -	952 DIA
JOURNALS -	254 x 127 (PLAIN BEARINGS)

ISSUE 1

EX. BR. DIAGRAM 641

BORAIL WAGON

YL003A

LOT NUMBER	
4012	

TOPS INFORMATION					
AARKND	OPERATING	OPERATING SPEED		BRAKE FORCE DATA	EXCESS LENGTH
CARKND	PANEL NO.	60 mile/h UP TO 80		† FORCE UP TO	
Y L A C	3 0 5 1	— mile/h ABOVE — tonne GLW		† FORCE ABOVE tonne GLW	

VARIABLE LOAD BRAKE

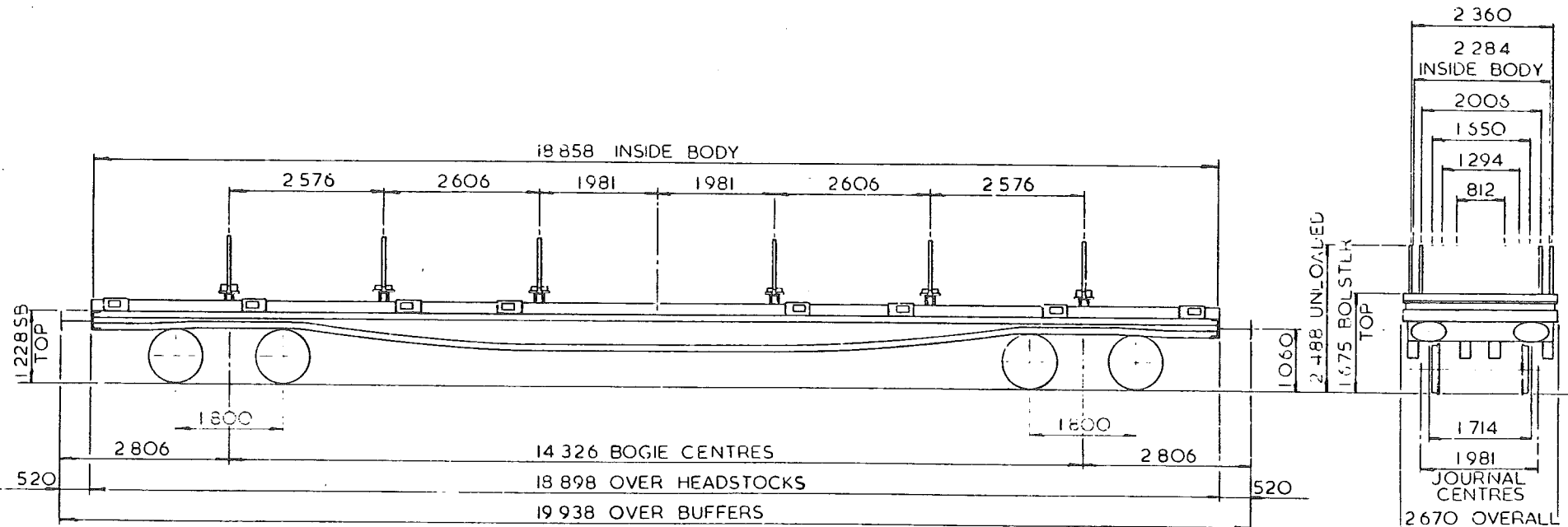

TARE - 31 000 kg.
CAPACITY, WEIGHT - 49 000 kg.
CAPACITY, VOLUME -
MIN CURVE - 31m
GEN ARRGT. DRG NO. - D4 S 2 224 255 D4 A 2 2 205 466 (ECLIPSE WHEELS & FITTINGS) F-S-12050 (20 GILS)

BRAKE - AIR DISC, SCREW HAND ON BOGIE
SUSPENSION - PRIMARY COIL
COUPLINGS - BR SCREW
BUFFERS - SELF CONTAINED 610x355 OVAL HEADS
WHEELS - 220 DIAMETER
JOURNALS - 130 DIAMETER ROLLER BEARINGS

ISSUE 1

41 TONNE BOGIE RAIL WAGON 'GANE A'

YL 500 A

LOT NUMBER	

TOPS INFORMATION				
AARKND	OPERATING	OPERATING SPEED		BRAKE FORCE DATA
CARKND	PANEL NO.	50 mile/h UP TO		EXCESS LENGTH
Y L O A	7 0 6 7	- mile/h ABOVE 60 tonne GLW		
				NO POWER BRAKE

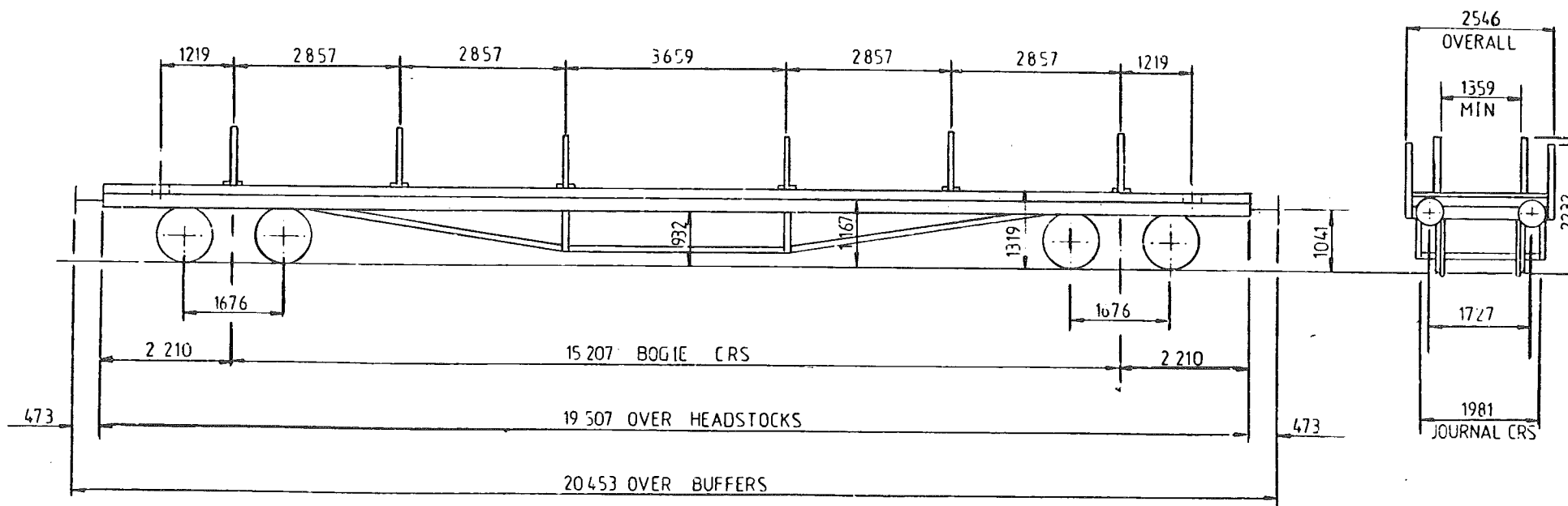

TARE -	19700 Kg
CAPACITY, WEIGHT -	40650 Kg
CAPACITY, VOLUME -	
MIN. CURVE -	70m
GEN. ARRGT. DRG. N ^o -	E 25872
BOGIE G. A. DRG. N ^o -	E 25873

BRAKE -	HAND SCREW
SUSPENSION -	SECONDARY COIL
COUPLINGS -	INSTANTER
BUFFERS -	SELF CONTAINED, 457 DIA HEADS
WHEELS -	965 DIA
JOURNALS -	127 x 254 (PLAIN BEARINGS)

ISSUE 1

EX S.R. DIAGRAM 1598

41 TONNE BOGIE RAIL WAGON 'GANE A'

YL 500 B

LOT NUMBER	

TOPS INFORMATION					
AARKND	OPERATING	OPERATING SPEED		BRAKE FORCE DATA	EXCESS LENGTH
CARKND	PANEL NO.	50 mile/h UP TO		NO POWER BRAKE	
Y L O A	7 0 6 8	mile/h ABOVE 61 tonne GLW			

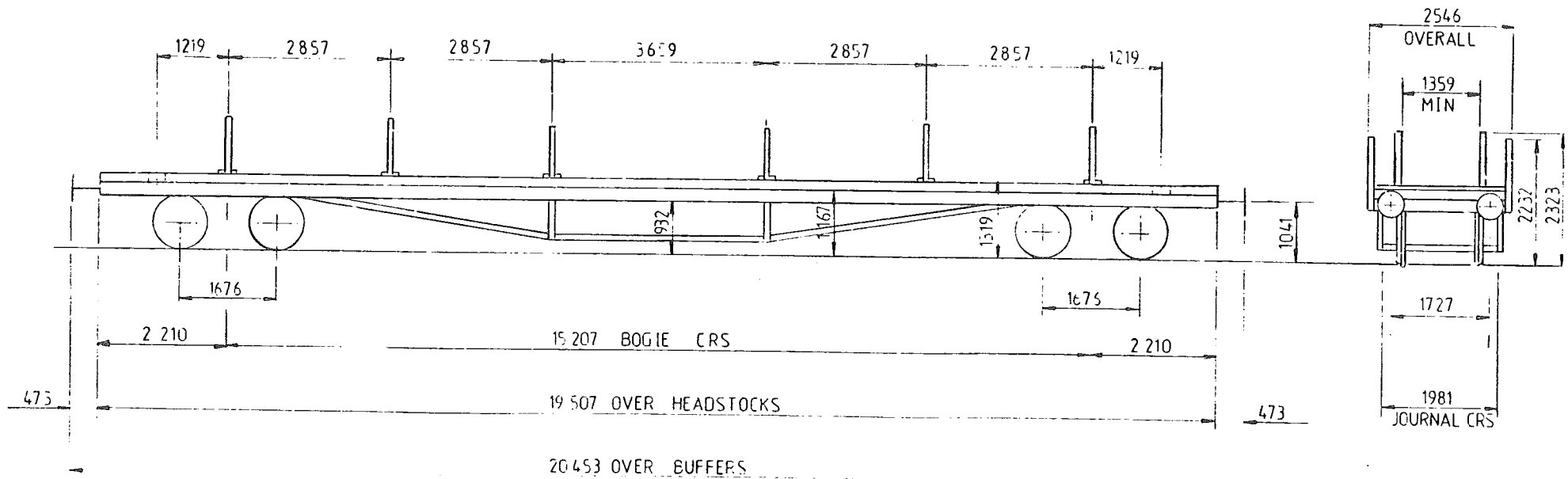

TARE -	20,000 Kg
CAPACITY, WEIGHT -	40,000 Kg
CAPACITY, VOLUME -	
MIN. CURVE -	70 m
GEN. ARRGT. DRG. NO. -	E 37463
BOGIE G A DRG. NO. -	E 36273

BRAKE -	HAND SCREW
SUSPENSION -	SECONDARY COIL
COUPLINGS -	INSTANTER
BUFFERS -	SELF CONTAINED, 457 DIA HEADS
WHEELS -	965 DIA
JOURNALS -	127 x 254 (PLAIN BEARINGS)

ISSUE 1

EX. S.R. DIAGRAM 599

41 TONNE BOGIE RAIL WAGON 'GANE A'

YL 500 C

LOT NUMBER	
1214	
1290	

TOPS INFORMATION					
AARKND	OPERATING	OPERATING SPEED		BRAKE FORCE DATA	EXCESS LENGTH
CARKND	PANEL NO.	50 mile/h UP TO		NO POWER BRAKE	
Y L O A	8 7 9 1	mile/h ABOVE 63 tonne GLW			

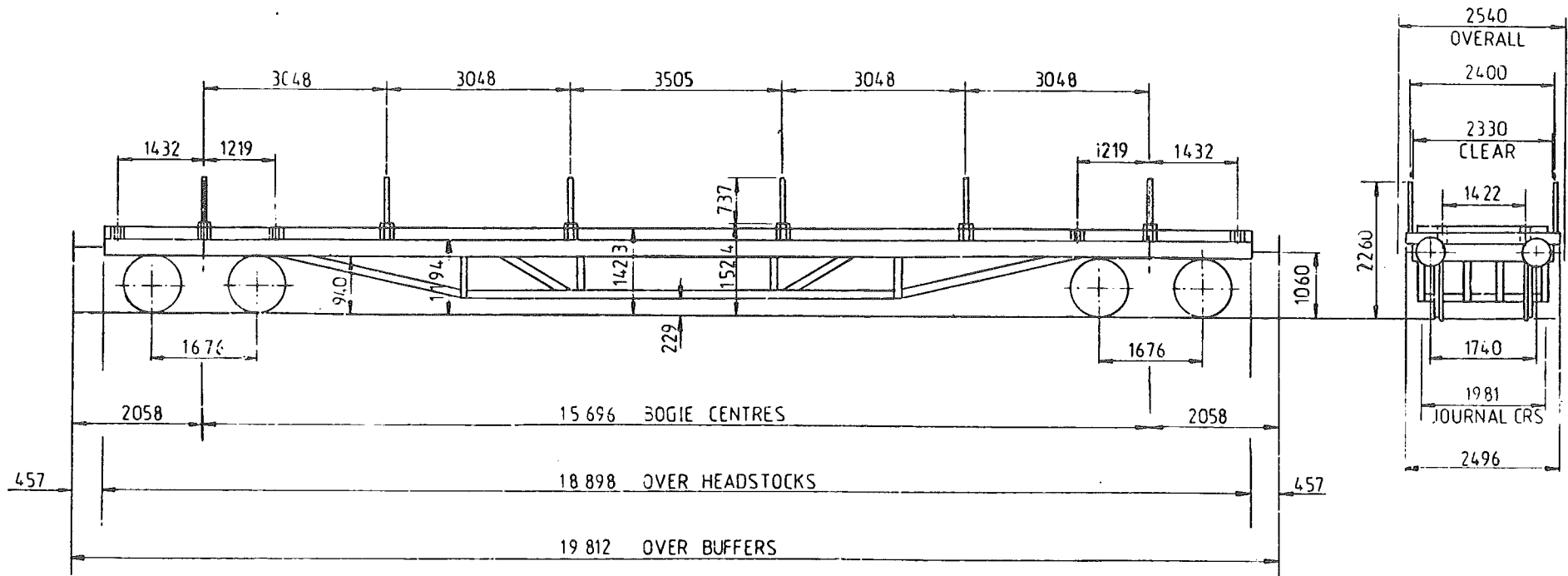

TARE -	21950 Kg
CAPACITY, WEIGHT -	40650 Kg
CAPACITY, VOLUME -	
MIN. CURVE -	41m
GEN ARRGT. DRG NO -	108309 A
BOGIE G.A. DFG NO -	52161

BRAKE -	HAND LEVER
SUSPENSION -	SECONDARY COIL
COUPLINGS -	INSTANTER
BUFFERS -	HYDRAULIC 508 DIA HEADS
WHEELS -	952 DIA
JOURNALS -	254 x 127 (PLAIN BEARINGS)

ISSUE 1

EX.GWR DIAGRAM J 26

41 TONNE BOGIE RAIL WAGON 'GANE A'

YL 500 D

LOT NUMBER	
1378	1463
1415	1533
1440	

TOPS INFORMATION					
AARKND	OPERATING	OPERATING SPEED		BRAKE FORCE DATA	EXCESS LENGTH 11
CARKND	PANEL NO.	50 mile/h UP TO		NO POWER BRAKE	
Y L O A	0 1 3 7	—mile/h ABOVE— 62 tonne GLW			

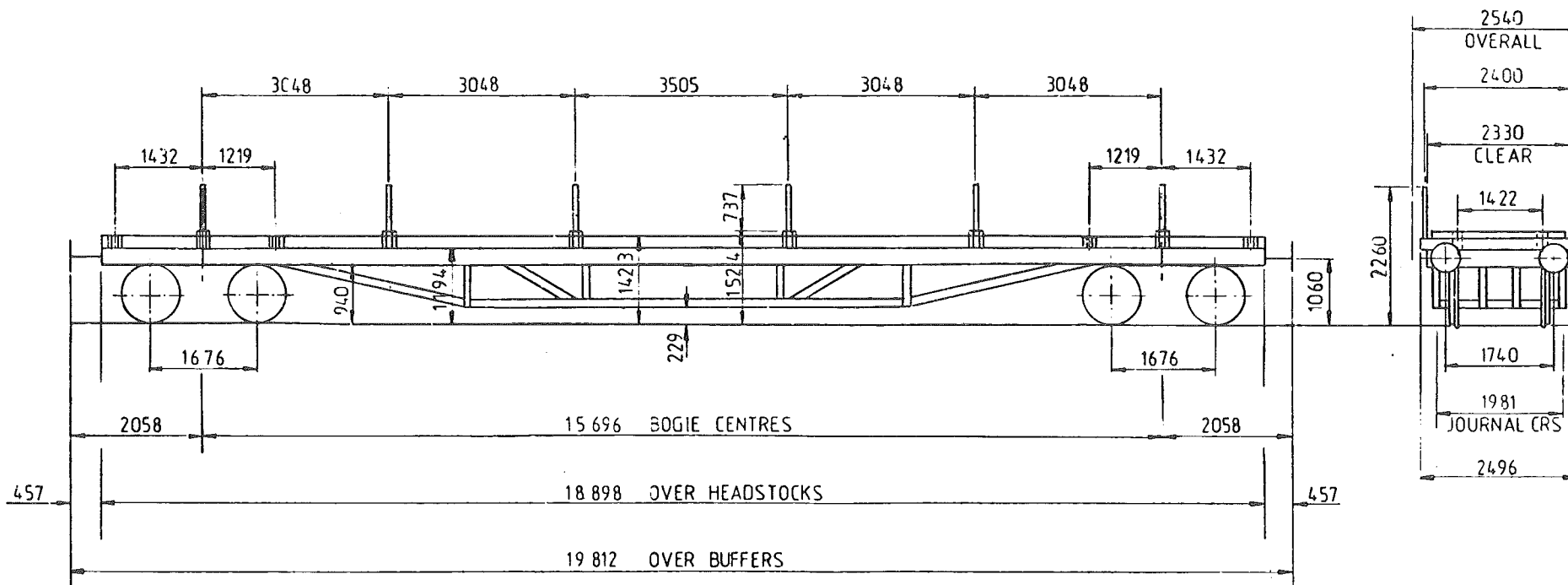

TARE -	21950 Kg
CAPACITY, WEIGHT -	40650 Kg
CAPACITY, VOLUME -	
MIN. CURVE -	41m
GEN. ARRGT. DRG. N ^o -	108309 A
BOGIE G.A. DRG. N ^o -	52161

BRAKE -	HAND LEVER
SUSPENSION -	SECONDARY COIL
COUPLINGS -	INSTANTER
BUFFERS -	HYDRAULIC 503 DIA HEADS
WHEELS -	952 DIA
JOURNALS -	254 x 127 (PLAIN BEARINGS)

ISSUE 1

41 TONNE BOGIE RAIL WAGON 'GANE A'

YL 500 E

LOT NUMBER	

TOPS INFORMATION					
AARKND	OPERATING	OPERATING SPEED		BRAKE FORCE DATA	EXCESS LENGTH
CARKND	PANEL NO.	50 mile/h UP TO		NO POWER BRAKE	
Y L P A	7 0 2 7	mile/h ABOVE 60 tonne GLW			

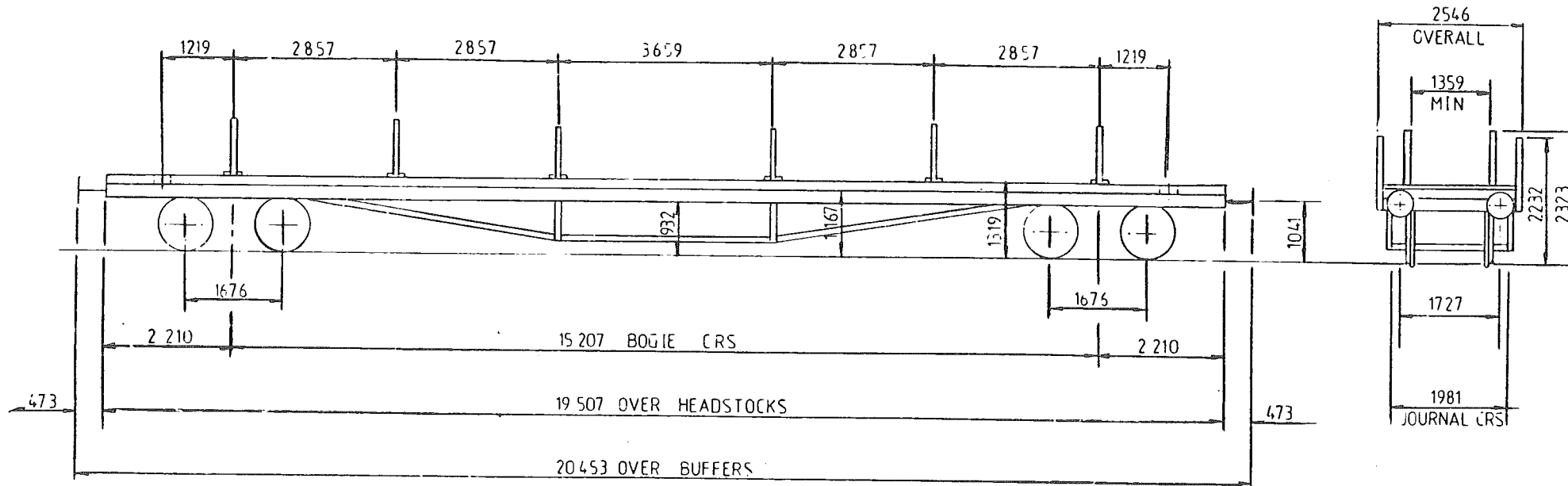

TARE -	19700 kg
CAPACITY, WEIGHT -	40000 kg
CAPACITY, VOLUME -	
MIN. CURVE -	70m
GEN ARRGT DRG NO -	L 15-72
BOGIE C.A. DRG NO -	E 20073

BRAKE -	HAND SCREW & VACUUM PIPE
SUSPENSION -	SECONDARY COIL
COUPLINGS -	INSTANTER
BUFFERS -	SELF CONTAINED, 457 DIA HEADS
WHEELS -	965 DIA
JOURNALS -	127 x 254 (PLAIN BEARINGS)

ISSUE 1

EX S.R. DIAGRAM 1598

BOGIE RAIL WAGON - 'SALMON'

YM 500 A

LOT NUMBER	
2011	
2216	
2399	

TOPS INFORMATION											
AARKND		OPERATING		OPERATING SPEED				BRAKE FORCE DATA		EXCESS LENGTH	
CARKND		PANEL NO.		50 mile/h UP TO				NO POWER BRAKE		11	
Y	M	O	A	0	2	8	9	45 mile/h ABOVE 24 tonne GLW			

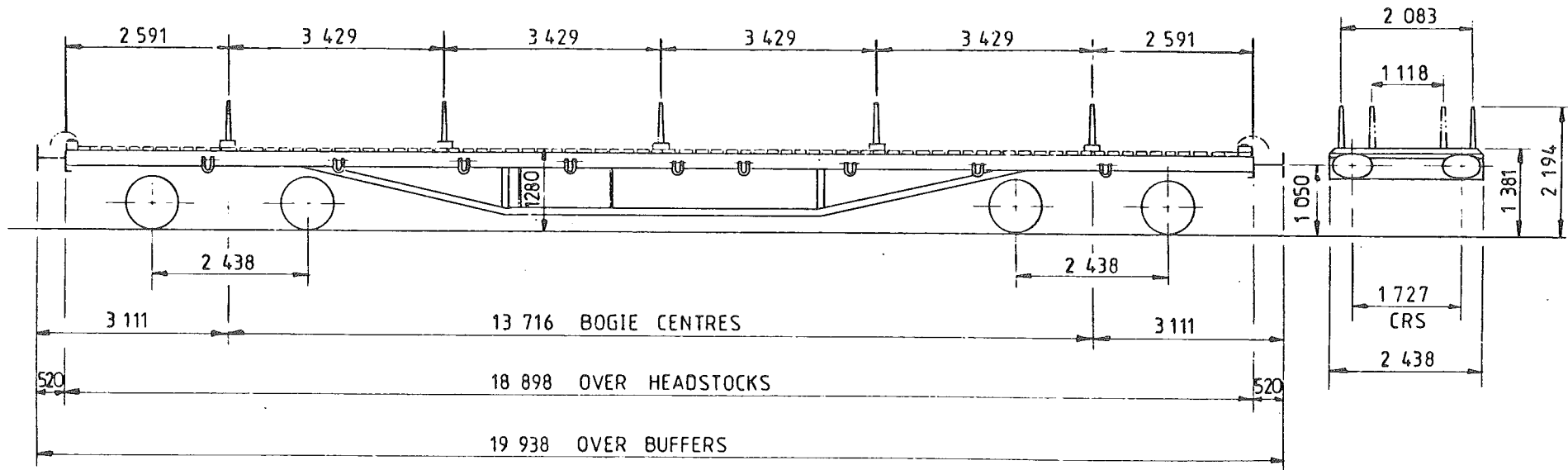

TARE -	24 300 kg
CAPACITY, WEIGHT -	51000 kg
CAPACITY, VOLUME -	—
MIN. CURVE -	51 m
GEN ARRGT. DRG NO. -	14/4479 & 11/452

BRAKE -	HAND LEVER ON BOGIE
SUSPENSION -	EYEBOLT & RUBBERS
COUPLINGS -	BR SCREW
BUFFERS -	HYDRAULIC, 610x305 OVAL HEADS
WHEELS -	825 DIA.
JOURNALS -	280 x 140 (11" x 5 1/2") PLAIN BEARINGS

ISSUE 1

EX. BR DIAGRAM 640

BOGIE RAIL WAGON - 'SALMON'

YM 500B

LOT NUMBER	
2534	
2363	

TOPS INFORMATION				
AARKND	OPERATING	OPERATING SPEED		EXCESS LENGTH
CARKND	PANEL NO.	50 mile/h UP TO 27 tonne GLW		NO POWER BRAKE
Y M O A	0 2 9 0	45 mile/h ABOVE		

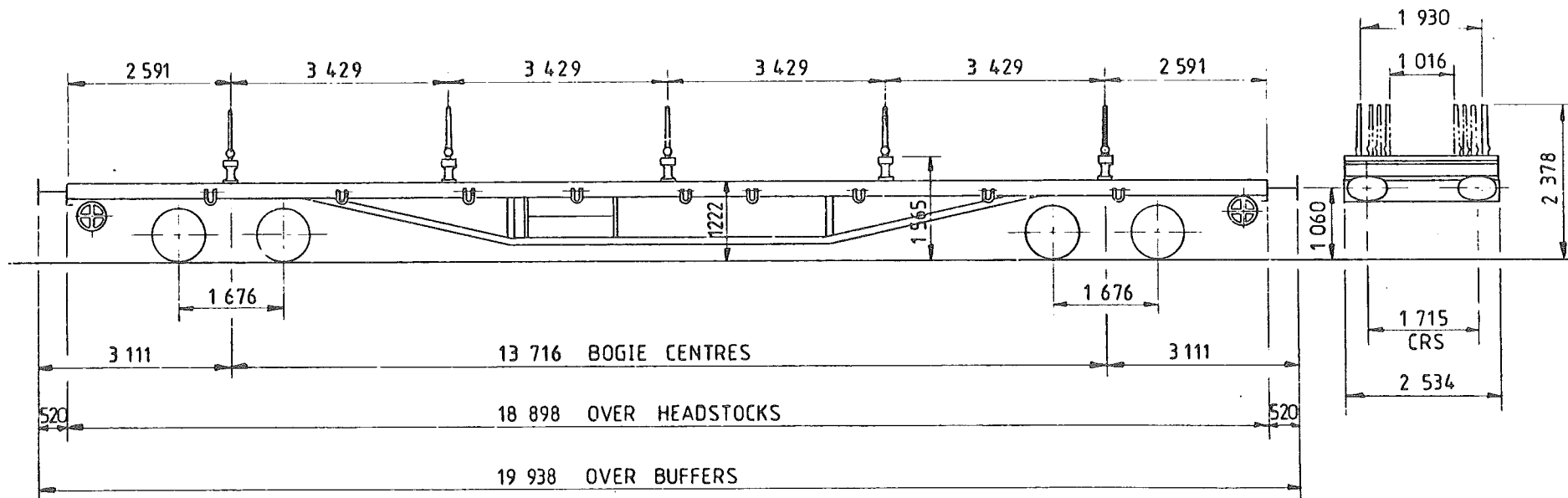

TARE -	27450 kg
CAPACITY, WEIGHT -	51000 kg
CAPACITY, VOLUME -	—
MIN. CURVE -	21 m
GEN. ARRGT. DRG. NO. -	SW-DN-6

BRAKE -	HAND SCREW
SUSPENSION -	SECONDARY COIL
COUPLINGS -	BR SCREW
BUFFERS -	HYDRAULIC, 610x305 OVAL HEADS
WHEELS -	838 DIA.
JOURNALS -	254x152(10x6) PLAIN BEARINGS

ISSUE 1

EX. BR DIAGRAM 642

BOGIE RAIL WAGON - 'SALMON'

YM 500C

LOT NUMBER	
2615	

TOPS INFORMATION					
AARKND	OPERATING	OPERATING SPEED		BRAKE FORCE DATA	EXCESS LENGTH 11
CARKND	PANEL NO.	50 mile/h UP TO 45 mile/h ABOVE		NO POWER BRAKE	
Y M O A	0 2 9 0				

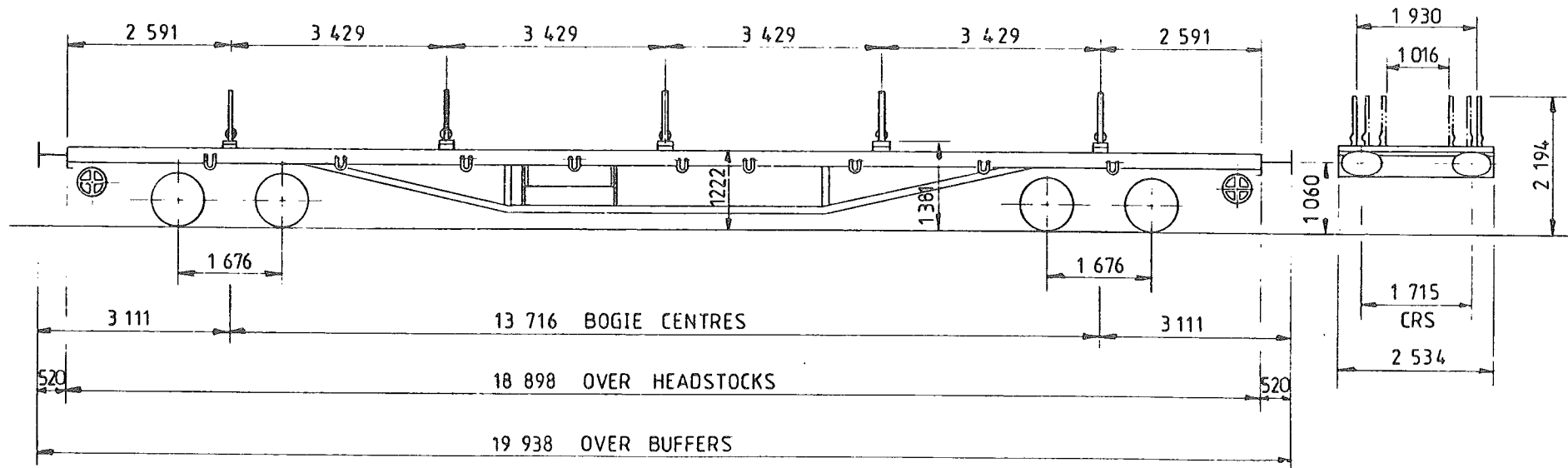

TARE -	26400kg
CAPACITY, WEIGHT -	51000kg
CAPACITY, VOLUME -	—
MIN. CURVE -	21 m
GEN ARRGT. DRG NO. -	SW · DN · 6

BRAKE -	HAND SCREW
SUSPENSION -	SECONDARY COIL
COUPLINGS -	BR SCREW
BUFFERS -	HYDRAULIC, 610x305 OVAL HEADS
WHEELS -	838 DIA
JOURNALS -	254x152(10"x6") PLAIN BEARINGS

ISSUE 1

BOGIE RAIL WAGON - 'SALMON'

YM 500D

LOT NUMBER	
2894	2926
3065	3067

TOPS INFORMATION										
AARKND		OPERATING		OPERATING SPEED			BRAKE FORCE DATA		EXCESS LENGTH	
CARKND		PANEL NO.		50 mile/h UP TO			NO POWER BRAKE		11	
Y	M	O	A	0	2	9	0	45 mile/h ABOVE 27 tonne GLW		

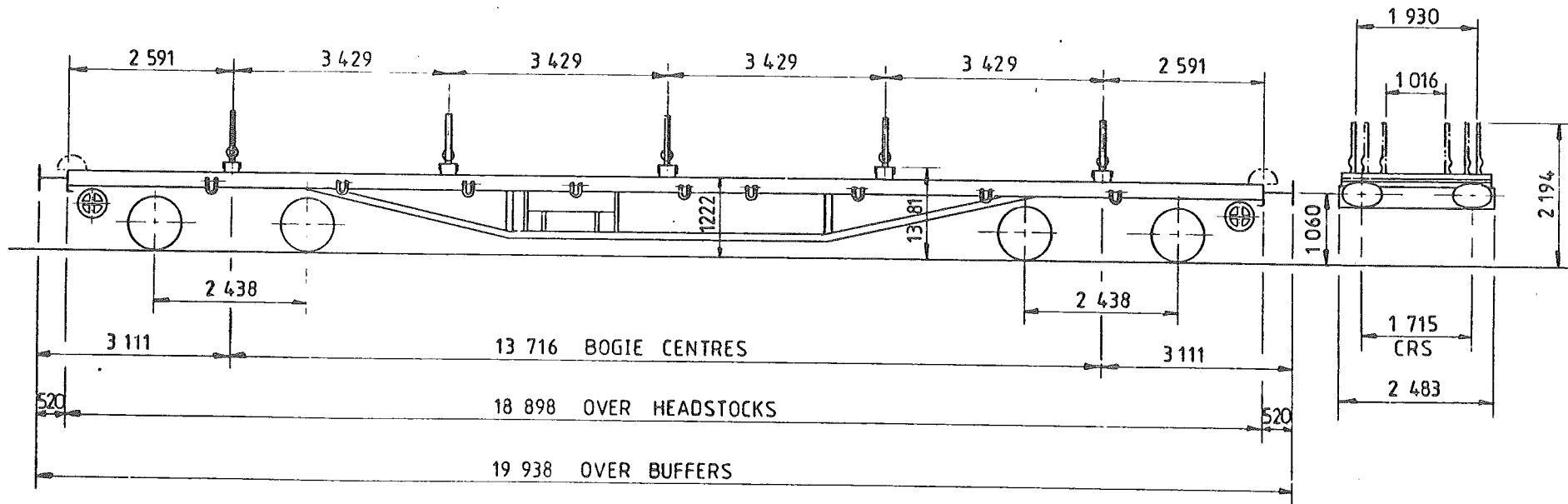

TARE -	27450 kg
CAPACITY, WEIGHT -	51000 kg
CAPACITY, VOLUME -	—
MIN. CURVE -	21 m
GEN. ARRGT. DRG. NO. -	SW - DN - 20738

BRAKE -	HAND SCREW
SUSPENSION -	SECONDARY COIL
COUPLINGS -	BR SCREW
BUFFERS -	HYDRAULIC, 610x305 OVAL HEADS
WHEELS -	812 DIA.
JOURNALS -	254x152(10"x6") PLAIN BEARINGS

ISSUE 1

EX. BR. DIAGRAM 646

BOGIE RAIL WAGON - 'SALMON'

YM 500E

LOT NUMBER	
LMS	1146

TOPS INFORMATION					
AARKND	OPERATING	OPERATING SPEED		BRAKE FORCE DATA	EXCESS LENGTH 11
CARKND	PANEL NO.	45 mile/h UP TO		NO POWER BRAKE	
Y M O A	B 7 6 0	40 mile/h ABOVE			

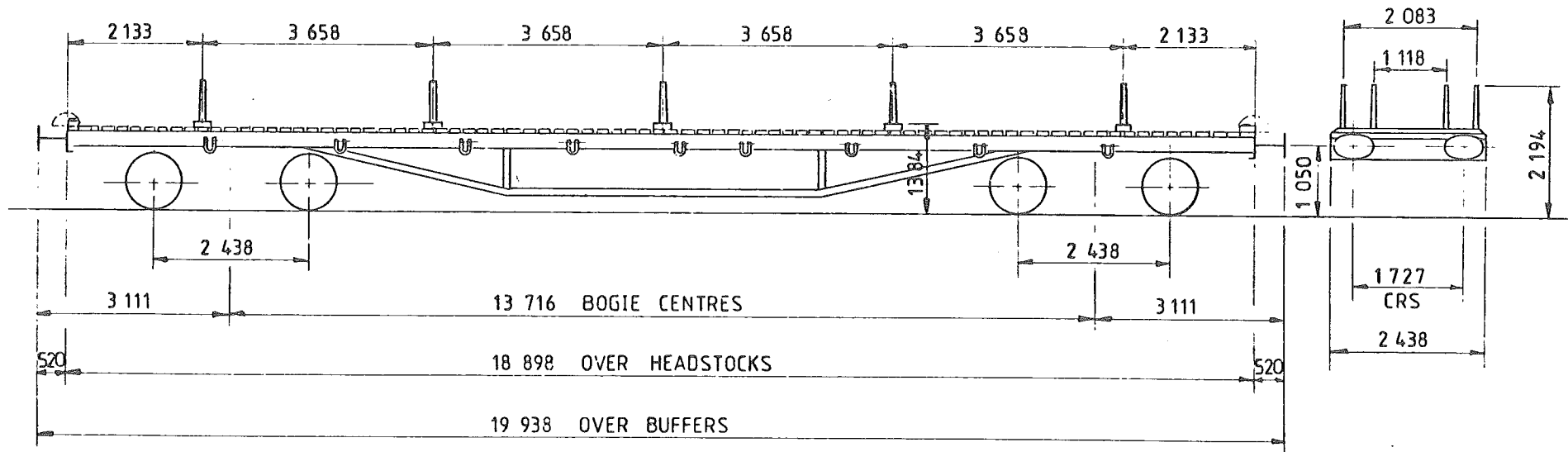

TARE -	23900 kg
CAPACITY, WEIGHT -	51000 kg
CAPACITY, VOLUME -	---
MIN. CURVE -	51 m
GEN. ARRGT. DRG. NOS -	11/294, & 14/2945

BRAKE -	HAND LEVER ON BOGIE
SUSPENSION -	EYEBOLT & RUBBERS
COUPLINGS -	BR SCREW
BUFFERS -	HYDRAULIC, 610x305 OVAL HEADS
WHEELS -	825 DIA.
JOURNALS -	280x140, (11"x5 1/2") PLAIN BEARINGS

ISSUE 1

EX LMS DIAGRAM 19 C

BOGIE RAIL WAGON - 'SALMON'

YM 500F

LOT NUMBER	
LMS	1159

TOPS INFORMATION				
AARKND	OPERATING	OPERATING SPEED		BRAKE FORCE DATA
CARKND	PANEL NO.	45 mile/h UP TO		EXCESS LENGTH 11
Y M O A	8 7 6 0	40 mile/h ABOVE 56 tonne GLW		
				NO POWER BRAKE

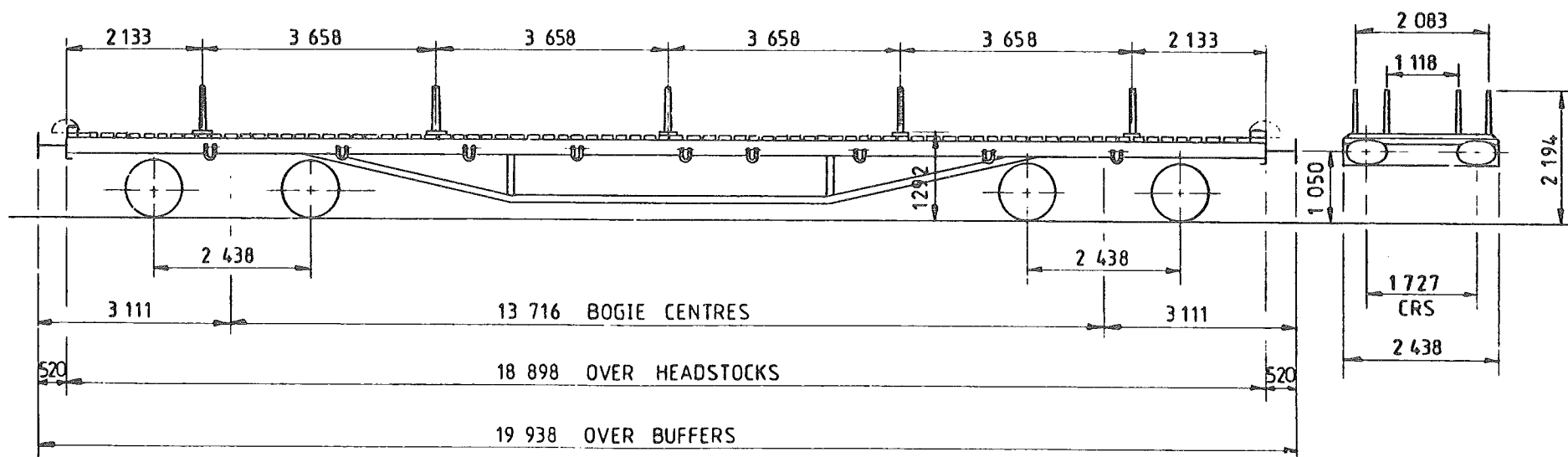

TARE -	23 600 kg
CAPACITY, WEIGHT -	51 000 kg
CAPACITY, VOLUME -	—
MIN. CURVE -	51 m
GEN ARRGT. DRG. N ^o -	11/325 , & 14/2945

BRAKE -	HAND LEVER ON BOGIE
SUSPENSION -	EYEBOLT & RUBBERS
COUPLINGS -	BR SCREW
BUFFERS -	HYDRAULIC, 610x305 OVAL HEADS
WHEELS -	825 DIA.
JOURNALS -	280 x 140, (11' x 5 1/2') PLAIN BEARINGS

ISSUE 1

BOGIE RAIL WAGON - 'SALMON'

YM 500G

LOT NUMBER	
LMS	1286
LMS	1292

TOPS INFORMATION										
AARKND		OPERATING		OPERATING SPEED			BRAKE FORCE DATA		EXCESS LENGTH	
CARKND		PANEL NO		45 mile/h UP TO			NO POWER BRAKE		11	
Y	M	O	A	8	7	6	0	40 mile/h ABOVE 56 tonne GLW		

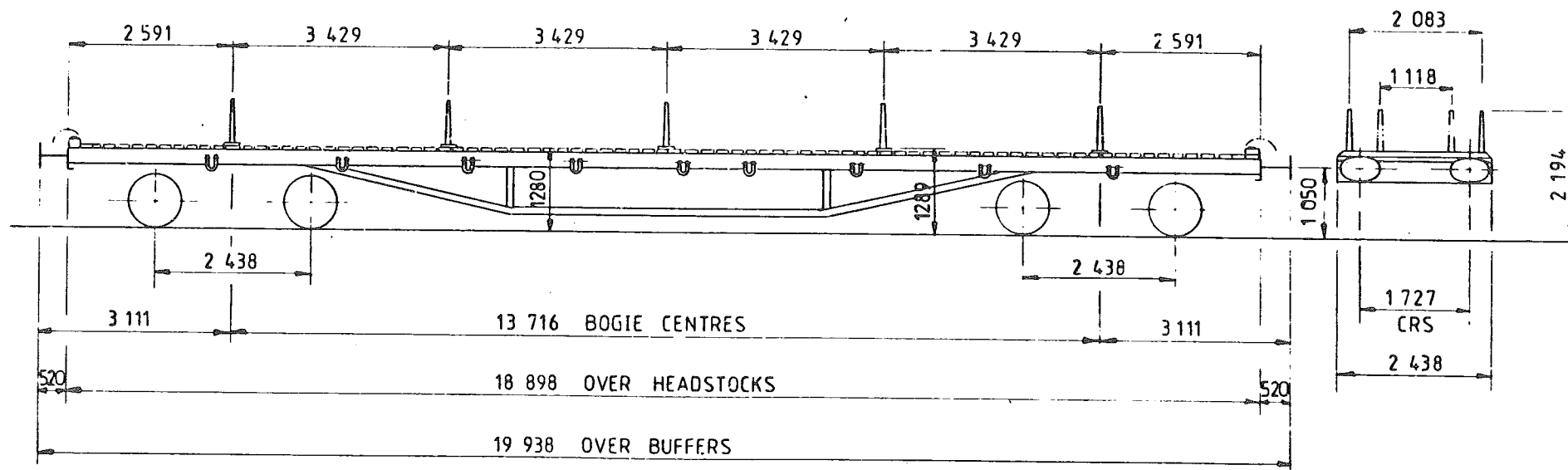

TARE -	23450 kg
CAPACITY, WEIGHT -	51000 kg
CAPACITY, VOLUME -	—
MIN CURVE -	51 m
GEN ARRGT. DRG NO. -	14/2945 & 11/427

BRAKE -	HAND LEVER ON BOGIE
SUSPENSION -	EYEBOLT & RUBBERS
COUPLINGS -	BR SCREW
BUFFERS -	HYDRAULIC, 610x305 OVAL HEADS
WHEELS -	825 DIA. •
JOURNALS -	280 x 140 (11" x 5 1/2") PLAIN BEARINGS

ISSUE 1

EX LMS DIAGRAM 19E

BOGIE RAIL WAGON - 'SALMON'

YM 500 H

LOT NUMBER	
LMS	1319

TOPS INFORMATION										
AARKND		OPERATING		OPERATING SPEED			BRAKE FORCE DATA		EXCESS LENGTH	
CARKND		PANEL NO		45 mile/h UP TO			NO POWER BRAKE		11	
Y	M	O	A	8	7	6	0	40 mile/h ABOVE 56 tonne GLW		

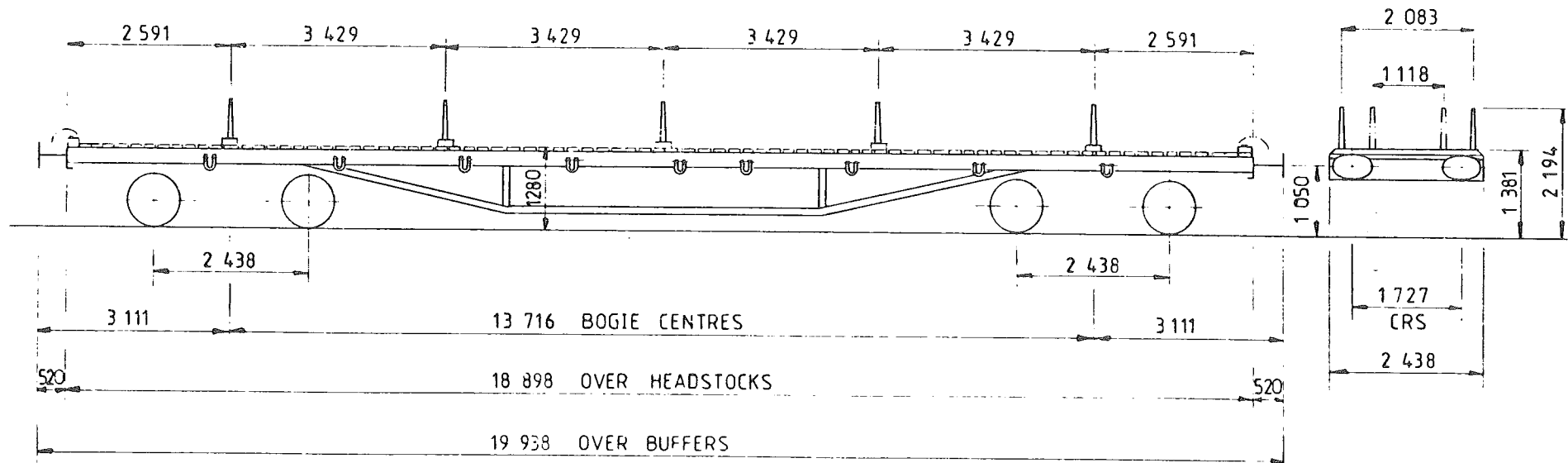

TARE -	24300 kg
CAPACITY WEIGHT -	51000 kg
CAPACITY VOLUME -	---
MIN CURVE -	51 m
GEN APPR: DRG NO -	14/2945 & 11/452

BRAKE	HAND LEVER ON BOGIE
SUSPENSION	EYEBOLT & RUBBERS
COUPLINGS -	BR SCREW
BUFFERS -	HYDRAULIC, 610x305 OVAL HEADS
WHEELS -	825 DIA
JOURNALS -	280x140 (1 1/2") PLAIN BEARINGS

ISSUE 1

BOGIE RAIL WAGON - 'SALMON'

YM 500 K

LOT NUMBER	
3261	
3262	
3284	

TOPS INFORMATION						
AARKND	OPERATING		OPERATING SPEED		BRAKE FORCE DATA	
CARKND	PANEL NO.		50 mile/h UP TO		NO POWER BRAKE	
Y M P A	0 2 8 8	45 mile/h ABOVE		EXCESS LENGTH		
					28 tonne GLW	
					12	

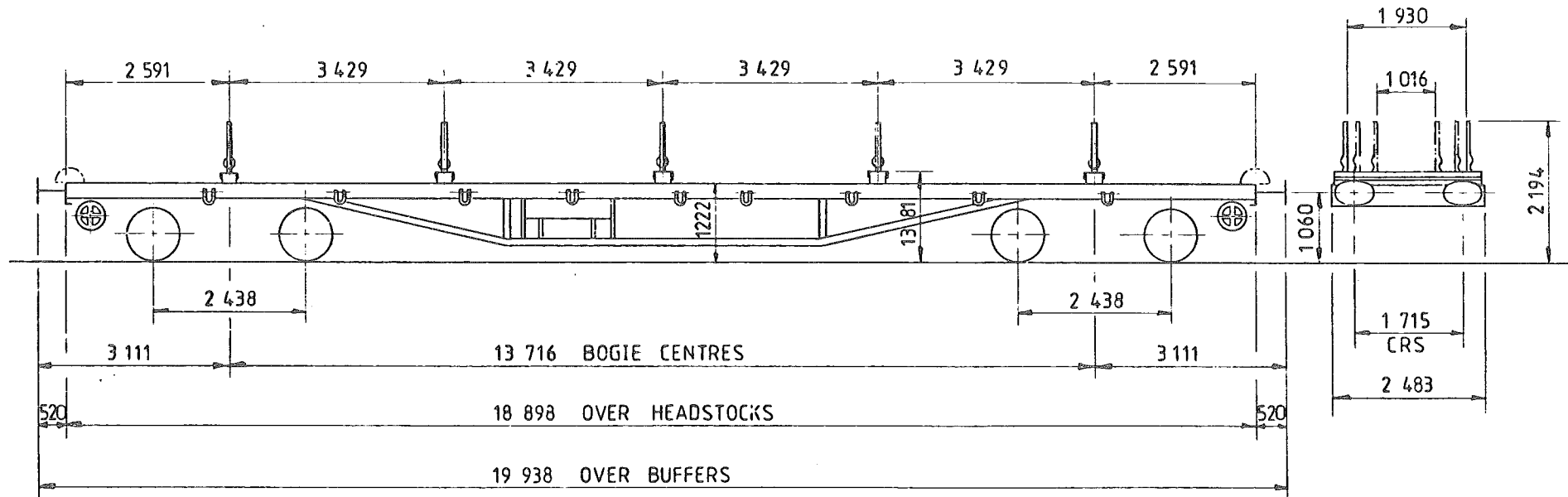

TARE -	28 100 kg
CAPACITY, WEIGHT -	51 000 kg
CAPACITY, VOLUME -	—
MIN. CURVE -	21 m
GEN. ARRGT. DRG. N ^o - SW - DN - 27872	
BOGIE - SW - DN - 20879	

BRAKE -	HAND SCREW & VACUUM PIPE
SUSPENSION -	SECONDARY COIL
COUPLINGS -	BR SCREW
BUFFERS -	HYDRAULIC, 610x305 OVAL HEADS
WHEELS -	812 DIA.
JOURNALS -	254x152(10"x6") PLAIN BEARINGS

ISSUE 1

EX. BR. DIAGRAM 637

BOGIE RAIL WAGON - 'SALMON'

YM 500 L

LOT NUMBER	
2363	

TOPS INFORMATION					
AARKND	OPERATING	OPERATING SPEED		BRAKE FORCE DATA	EXCESS LENGTH
CARKND	PANEL NO.	50 mile/h UP TO 45 mile/h ABOVE		NO POWER BRAKE	
Y M P A	8 8 1 3	27 tonne GLW			11

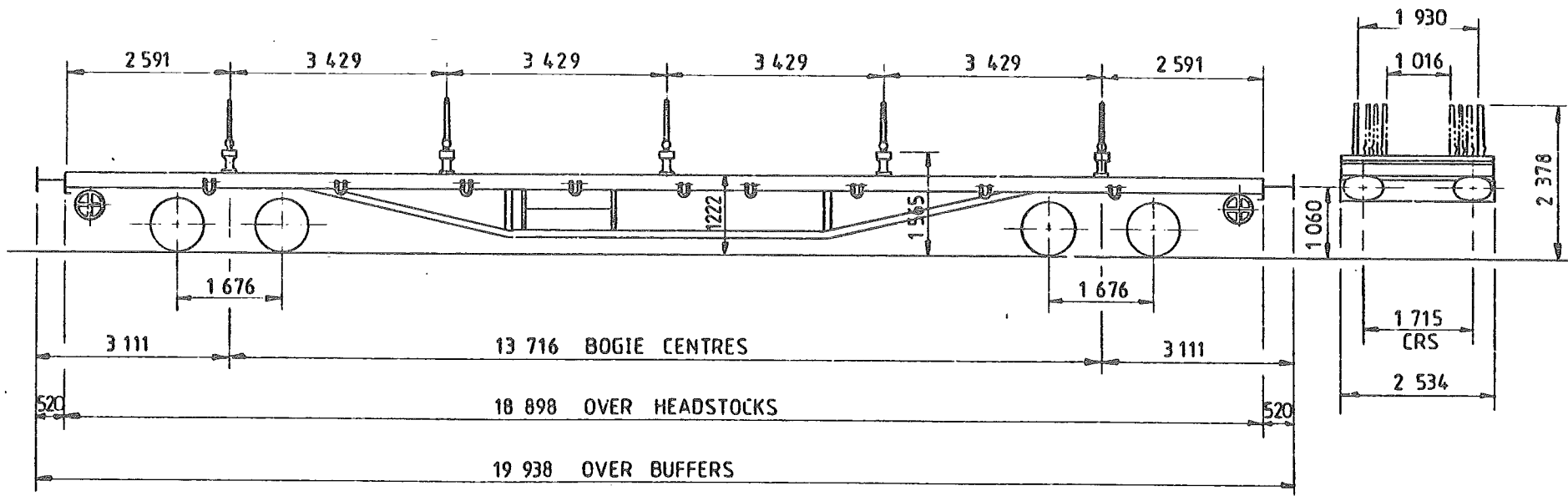

TARE -	27450 kg
CAPACITY, WEIGHT -	51000 kg
CAPACITY, VOLUME -	---
MIN. CURVE -	21 m
GEN. ARRGT, DRG. NO. -	SW-DN-6

BRAKE -	HAND SCREW & VACUUM PIPE
SUSPENSION -	SECONDARY COIL
COUPLINGS -	BR SCREW
BUFFERS -	HYDRAULIC, 610x305 OVAL HEADS
WHEELS -	838 DIA.
JOURNALS -	254x152(10"x6") PLAIN BEARINGS

ISSUE 1

EX. BR. DIAGRAM 642

BOGIE RAIL WAGON - 'SALMON'

YM 500 M

LOT NUMBER	
	2926

TOPS INFORMATION						
AARKND		OPERATING		OPERATING SPEED		BRAKE FORCE DATA
CARKND		PANEL NO.		50 mile/h UP TO		EXCESS LENGTH
Y M P A		8 8 1 0		45 mile/h ABOVE		11
				27 tonne GLW		NO POWER BRAKE

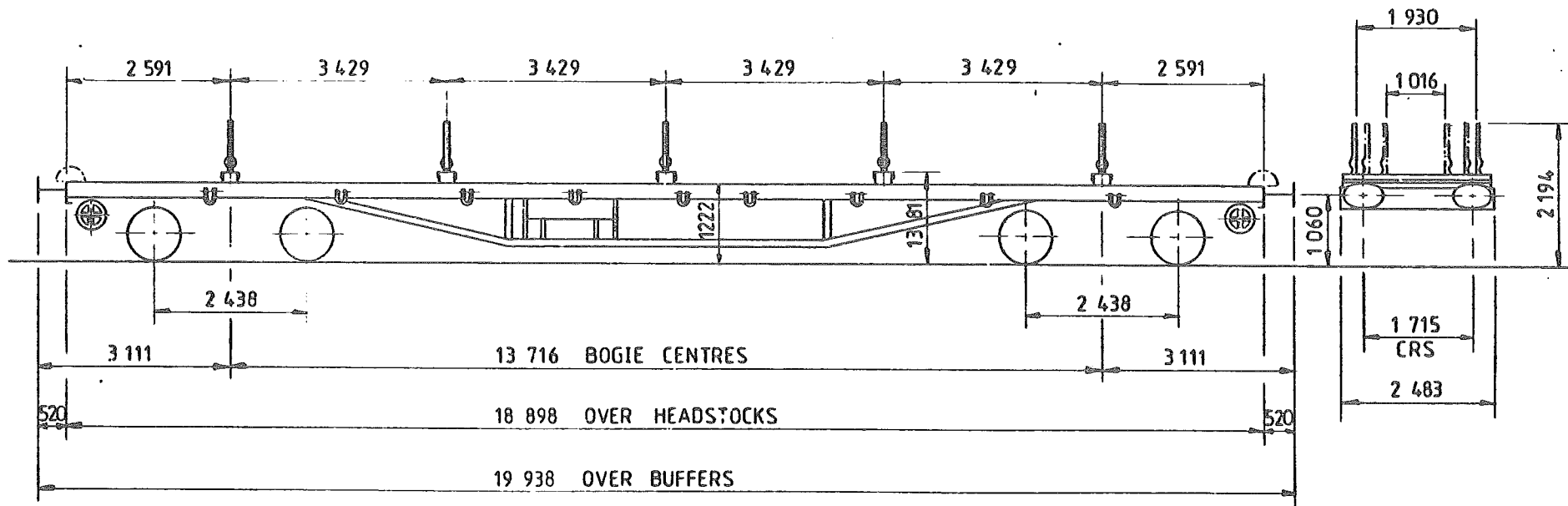

TARE -	27450 kg
CAPACITY, WEIGHT -	51000 kg
CAPACITY, VOLUME -	—
MIN. CURVE -	21 m
GEN. ARRGT. DRG. NO. -	SW - DN - 20738

BRAKE -	HAND SCREW & VACUUM PIPE
SUSPENSION -	SECONDARY COIL
COUPLINGS -	BR SCREW
BUFFERS -	HYDRAULIC, 610x305 OVAL HEADS
WHEELS -	812 DIA.
JOURNALS -	254x152(10x6) PLAIN BEARINGS

ISSUE 1

EX. BR. DIAGRAM 646

BOGIE RAIL WAGON - 'SALMON'

YM 500N

LOT NUMBER	
2894	2926
3065	3067

TOPS INFORMATION											
AARKND		OPERATING		OPERATING SPEED		BRAKE FORCE DATA		EXCESS LENGTH 11			
CARKND		PANEL NO.		50 mile/h UP TO		22 t FORCE UP TO					
Y	M	A	A	0	2	9	1		45 mile/h ABOVE	28 tonne GLW	78 tonnes GLW

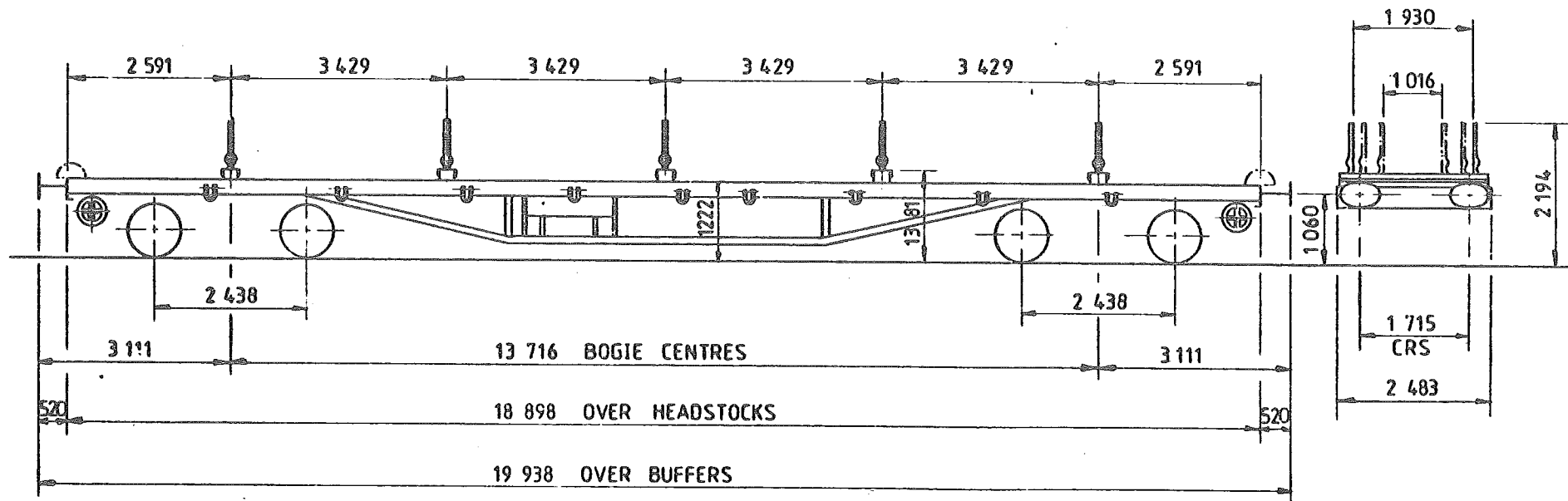

TARE -	26 900 kg
CAPACITY, WEIGHT -	51 000 kg
CAPACITY, VOLUME -	—
MIN. CURVE -	21 m
GEN. ARRGT. DRG. N ^o -	SW · DN · 20738

BRAKE -	AIR BLOCK & HAND SCREW
SUSPENSION -	SECONDARY FOIL
COUPLINGS -	BR SCREW
BUFFERS -	HYDRAULIC, 610 x 305 OVAL HEADS
WHEELS -	812 DIA.
JOURNALS -	254 x 152 (10 x 6) PLAIN BEARINGS

ISSUE 1

EX. BR. DIAGRAM 650

BOGIE RAIL WAGON - 'SALMON'

YM 500 P

LOT NUMBER	
2694	2926
3065	3067

TOPS INFORMATION					
AARKND	OPERATING	OPERATING SPEED		BRAKE FORCE DATA	EXCESS LENGTH 11
CARKND	PANEL NO.	50 mile/h UP TO		NO POWER BRAKE	
Y M P A	8 8 1 3	45 mile/h ABOVE			

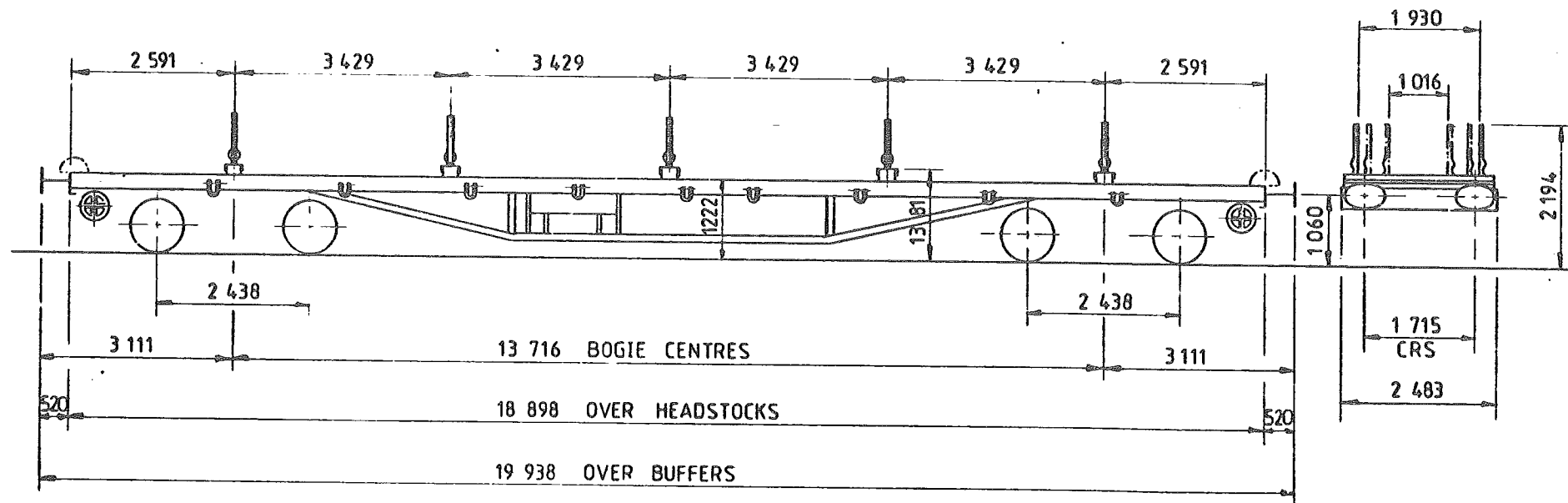

TARE -	27450 kg
CAPACITY, WEIGHT -	51000 kg
CAPACITY, VOLUME -	—
MIN. CURVE -	21 m
GEN. ARRGT. DRG. N ^o - SW - DN - 20738	
BOGIE - SW - DN - 20879	

BRAKE -	HAND SCREW & VACUUM PIPE
SUSPENSION -	SECONDARY COIL
COUPLINGS -	BR SCREW
BUFFERS -	HYDRAULIC, 610x305 OVAL HEADS
WHEELS -	812 DIA.
JOURNALS -	254x152(10"x6") PLAIN BEARINGS

ISSUE 1

EX. BR. DIAGRAM 646

BOGIE RAIL WAGON - 'SALMON'

YM 500 R

LOT NUMBER	
3262	
3284	
3352	

TOPS INFORMATION						
AARKND	OPERATING	OPERATING SPEED		BRAKE FORCE DATA		EXCESS LENGTH 12
CARKND	PANEL NO.	50 mile/h UP TO		22t FORCE UP TO		
Y M B A	8 4 0 8	-mile/h ABOVE		75 tonne GLW FORCE ABOVE		

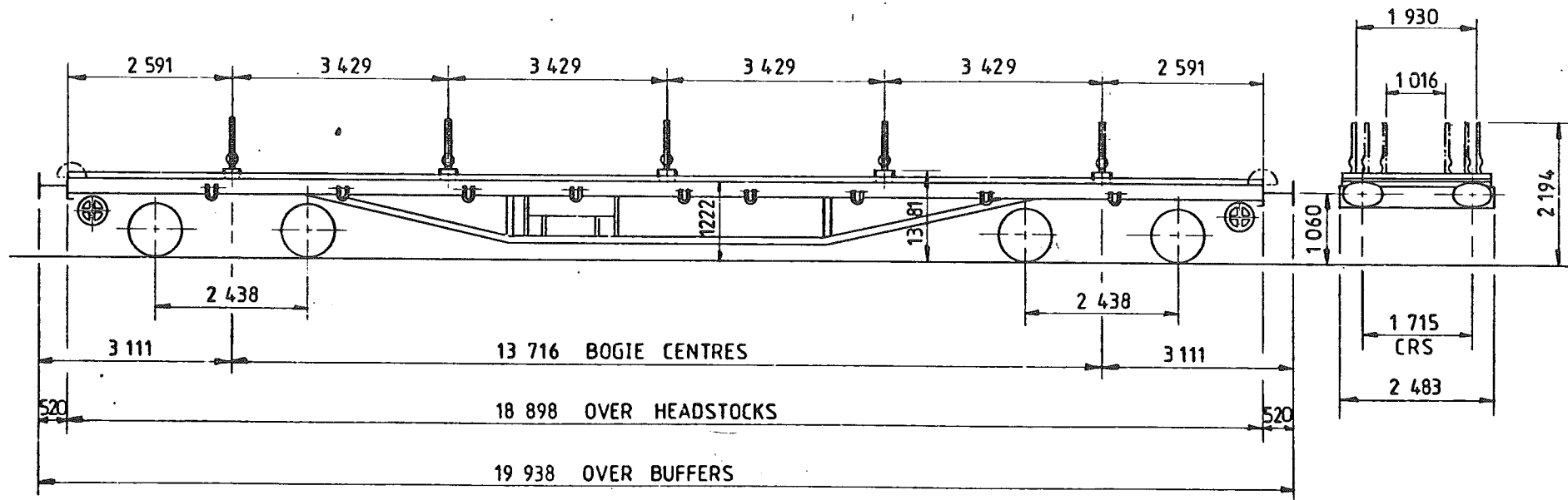

TARE -	23 950 kg
CAPACITY, WEIGHT -	51 000 kg
CAPACITY, VOLUME -	—
MIN. CURVE -	21 m
GEN. ARRGT. DRG. NO. -	SW · DN · 28604 & DN 833020

BRAKE -	AIR BLOCK, VACUUM PIPE & HAND SCREW
SUSPENSION -	SECONDARY COIL
COUPLINGS -	BR SCREW
BUFFERS -	HYDRAULIC, 610x305 OVAL HEADS
WHEELS -	812 DIA.
JOURNALS -	254x152(10x6) PLAIN BEARINGS

ISSUE 1

EX. BR. DIAGRAM 628

BOGIE RAIL WAGON - 'SALMON'

YM 5005

LOT NUMBER	
2926	
3065	

TOPS INFORMATION												
AARKND		OPERATING		OPERATING SPEED			BRAKE FORCE DATA		EXCESS LENGTH			
CARKND		PANEL NO.		50 mile/h UP TO			22† UP TO		11			
Y	M	B	A	8	4	0	8	78 tonne GLW			78 tonne GLW	
				-mile/h- ABOVE			-ABOVE-					

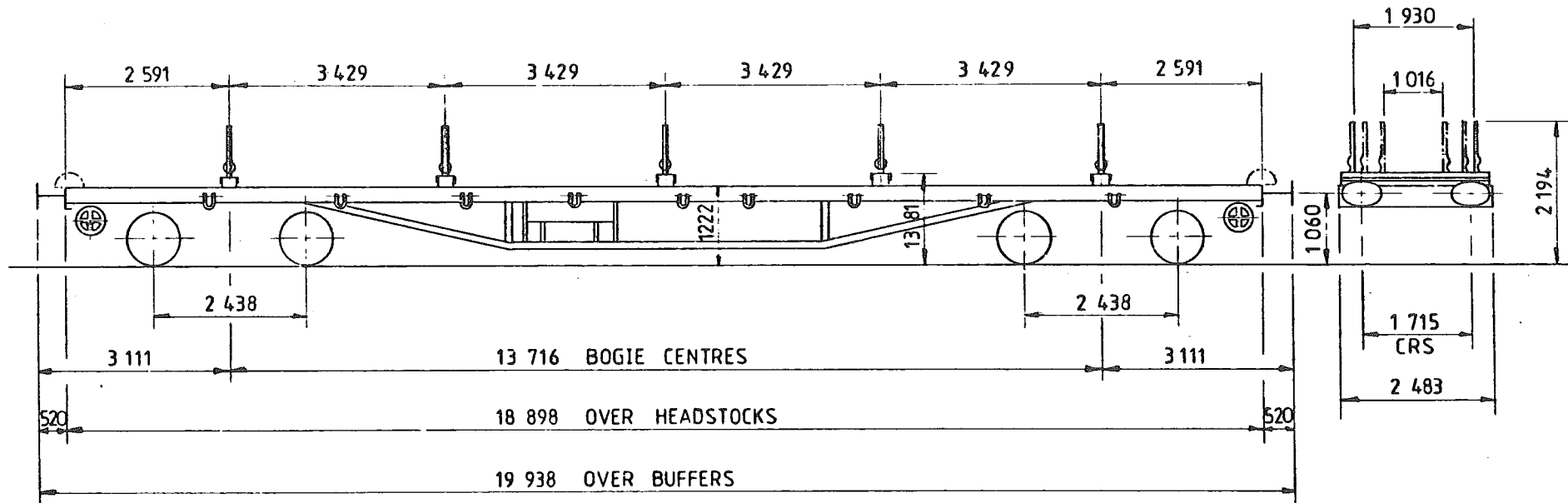

TARE -	27 650 kg
CAPACITY, WEIGHT -	51000 kg
CAPACITY, VOLUME -	—
MIN. CURVE -	21 m
GEN. ARRGT. DRG. NO. -	SW · DN · 20738

BRAKE -	AIR BLOCK, VAC. PIPE & HAND SCREW
SUSPENSION -	SECONDARY COIL
COUPLINGS -	BR SCREW
BUFFERS -	HYDRAULIC, 610×305 OVAL HEADS
WHEELS -	812 DIA.
JOURNALS -	254×152(10"×6") PLAIN BEARINGS

ISSUE 1

EX. BR. DIAGRAM 646

BOGIE RAIL WAGON - 'SALMON'

YM 500T

LOT NUMBER	
2534	

TOPS INFORMATION				
AARKND	OPERATING	OPERATING SPEED		EXCESS LENGTH
CARKND	PANEL NO.	50 mile/h UP TO		
Y M P A	8 8 1 3	45 mile/h ABOVE		
			27 tonne GLW	NO POWER BRAKE

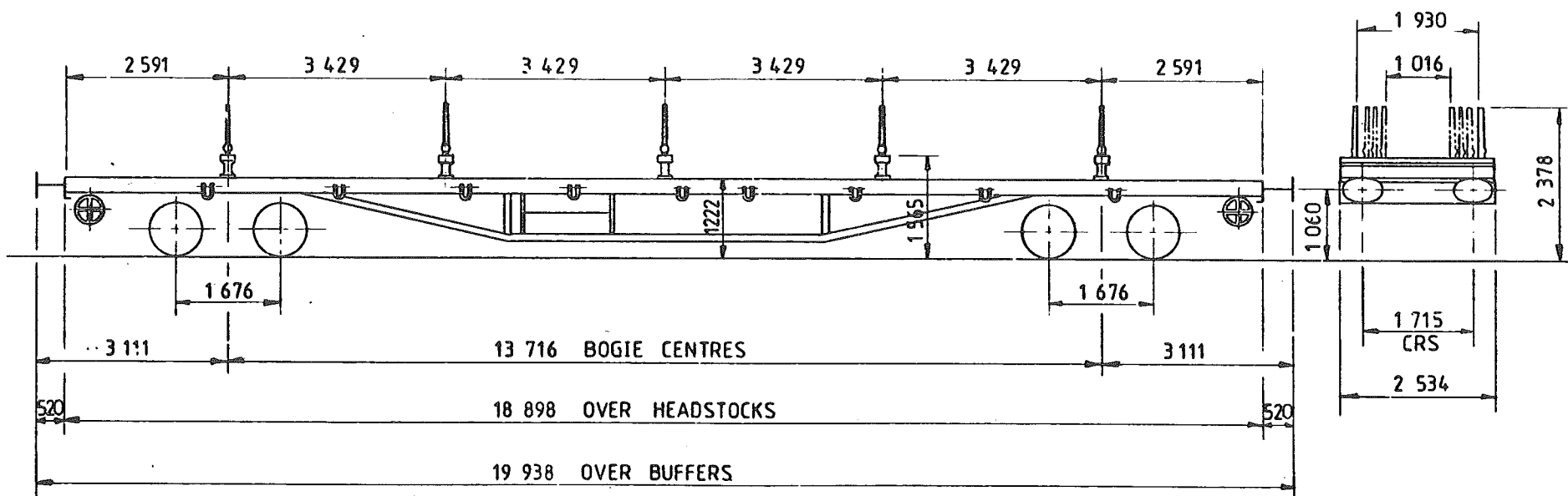

TARE -	27450 kg
CAPACITY, WEIGHT -	51000 kg
CAPACITY, VOLUME -	—
MIN. CURVE -	21 m
GEN. ARRGT. DRG. NO. -	SW-DN-6

BRAKE -	VACUUM THRO' PIPE & HAND SCREW
SUSPENSION -	SECONDARY COIL
COUPLINGS -	BR SCREW
BUFFERS -	HYDRAULIC, 610x305 OVAL HEADS
WHEELS -	838 DIA.
JOURNALS -	254x152(10'x6') PLAIN BEARINGS

ISSUE 1

EX. BR. DIAGRAM 642

BOGIE RAIL WAGON - 'SALMON'

YM 500 W

LOT NUMBER	
2399	2216

TOPS INFORMATION										
AARKND		OPERATING		OPERATING SPEED			BRAKE FORCE DATA		EXCESS LENGTH 11	
CARKND		PANEL NO.		50 mile/h UP TO			NO POWER BRAKE			
Y	M	P	A	8	7	6				

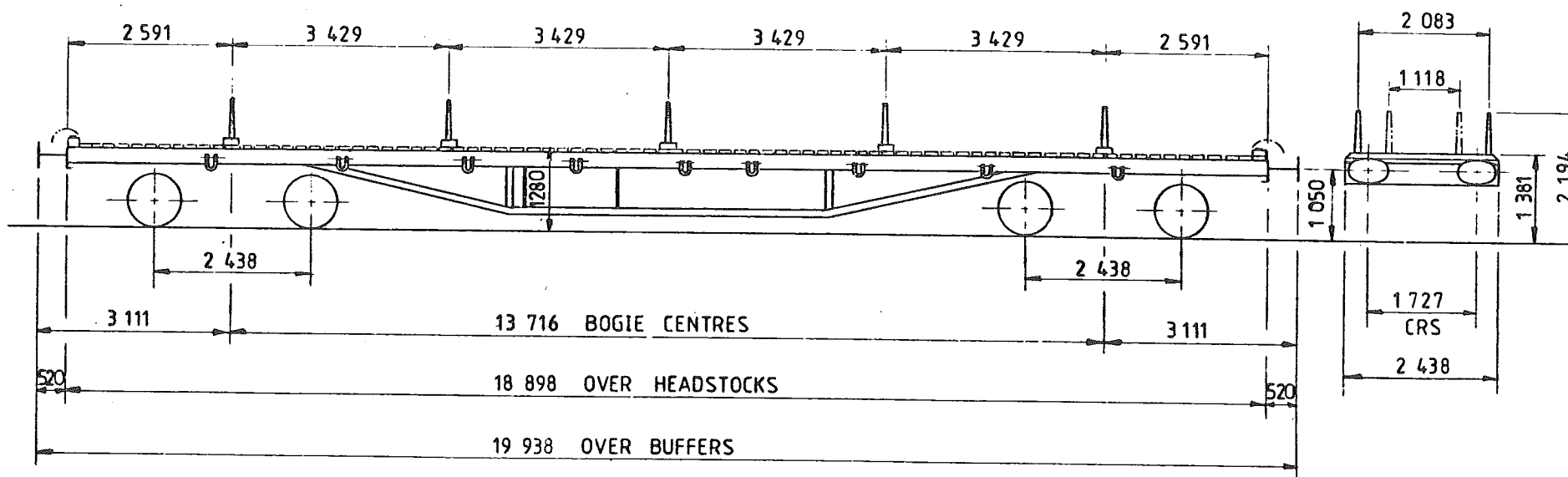

TARE -	24 300 kg
CAPACITY, WEIGHT -	51 000 kg
CAPACITY, VOLUME -	—
MIN. CURVE -	51 m
GEN. ARRGT. DRG. NO. -	14/4479 & 11/452

BRAKE -	VAC THRO. PIPE & HAND LEVER (ON BOGIE)
SUSPENSION -	EYEBOLT & RUBBERS
COUPLINGS -	BR SCREW
BUFFERS -	HYDRAULIC, 610x305 OVAL HEADS
WHEELS -	825 DIA.
JOURNALS -	280 x 140 (11" x 5 1/2") PLAIN BEARINGS

ISSUE 1

EX. BR. DIAGRAM 640

BOGIE BOLSTER WAGON

YN005A

LOT NUMBER	
2540	

TOPS INFORMATION					
AARKND	OPERATING	OPERATING SPEED		BRAKE FORCE DATA	EXCESS LENGTH 3
CARKND	PANEL NO.	50mile/h UP TO		NO POWER BRAKE	
Y N O E	0 0 2 6	mile/h ABOVE 46 tonne GLW			

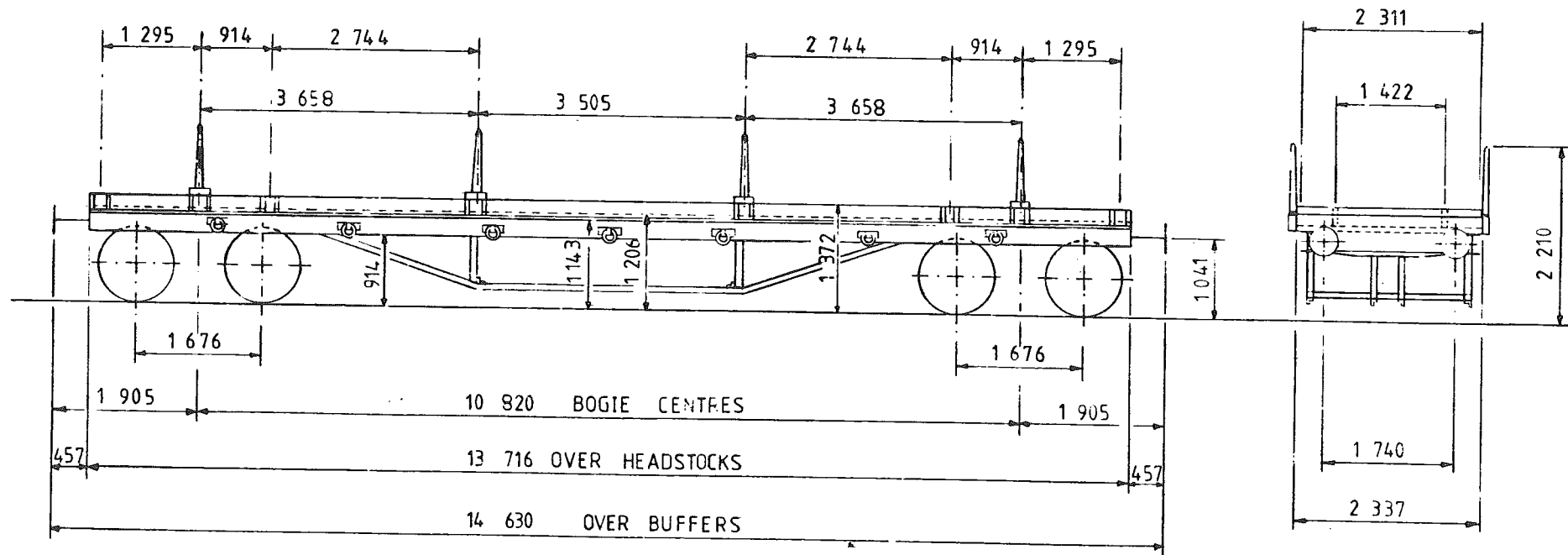

TARE -	15 ⁵⁰⁰ Kg
CAPACITY, WEIGHT -	30 ⁵⁰⁰ Kg
CAPACITY, VOLUME -	—
MIN. CURVE -	30 m
GEN. ARRGT. DRG. N ^o -	49281 ^A

BRAKE -	HAND LEVER VACUUM THRO' PIPE
SUSPENSION -	SECONDARY COIL
COUPLINGS -	INSTANTER
BUFFERS -	SELF CONTAINED 406 x 457 LIA HEADS
WHEELS -	952 DIA
JOURNALS -	114 x 203 (4 1/2" x 8) PLAIN BEARINGS

ISSUE 1

EX. BR DIAGRAM B473

BOGIE BOLSTER WAGON

YN006A

LOT NUMBER	
2308	

TOPS INFORMATION							
AARKND	OPERATING		OPERATING SPEED		BRAKE FORCE DATA		EXCESS LENGTH 3
CARKND	PANEL NO.		50 mile/h UP TO - mile/h ABOVE		NO POWER BRAKE		
Y N O B	0 0 2 6						

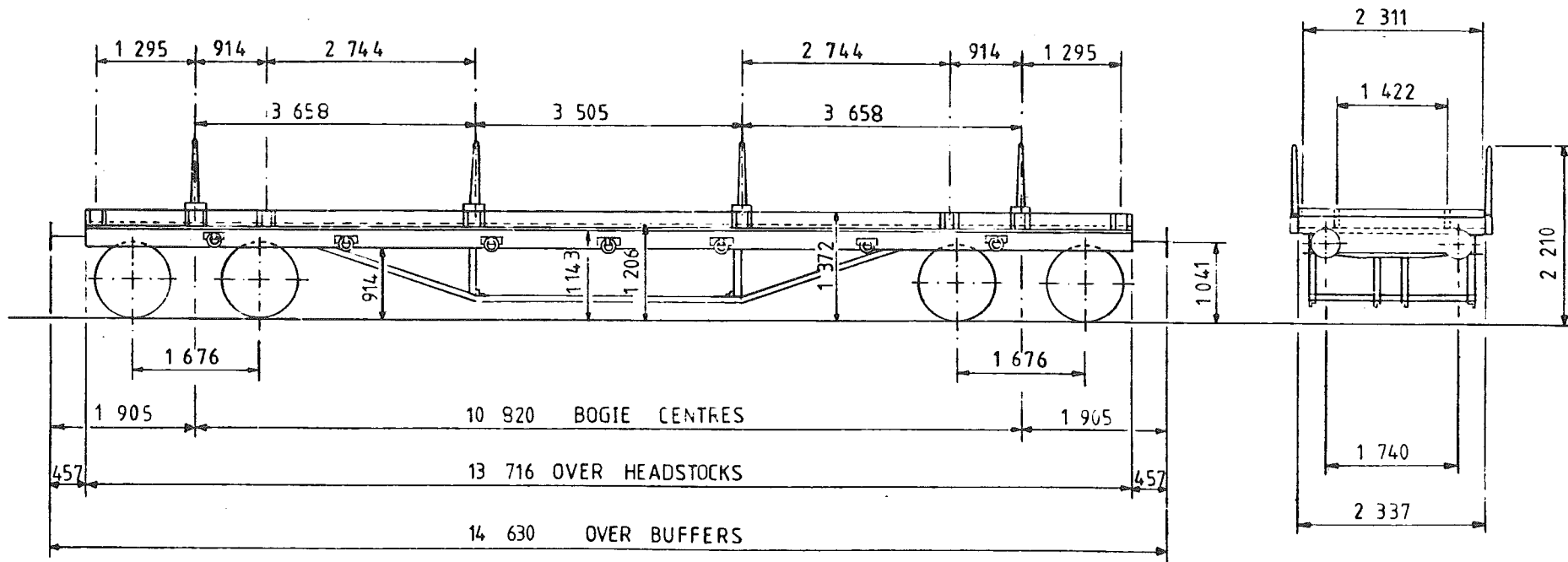

TARE -	15 ⁵⁰⁰ Kg
CAPACITY, WEIGHT -	30 ⁵⁰⁰ Kg
CAPACITY, VOLUME -	—
MIN. CURVE -	30 m
GEN. ARRGT. DRG. NO. -	49281 ^A

BRAKE -	HAND LEVER
SUSPENSION -	SECONDARY COIL
COUPLINGS -	INSTANTER
BUFFERS -	SELF CONTAINED 406 x 457 DIA HEADS
WHEELS -	952 DIA
JOURNALS -	114 x 203 (4 1/2 x 8) PLAIN BEARINGS

ISSUE 1

EX. BR DIAGRAM B471

BOGIE BOLSTER WAGON

YN007A

LOT NUMBER	
2759	

TOPS INFORMATION										
AARKND		OPERATING		OPERATING SPEED			BRAKE FORCE DATA		EXCESS LENGTH	
CARKND		PANEL NO.		50mile/h UP TO			NO POWER BRAKE		3	
Y	N	O	B	0	0	2	6	mile/h ABOVE 46tonne GLW		

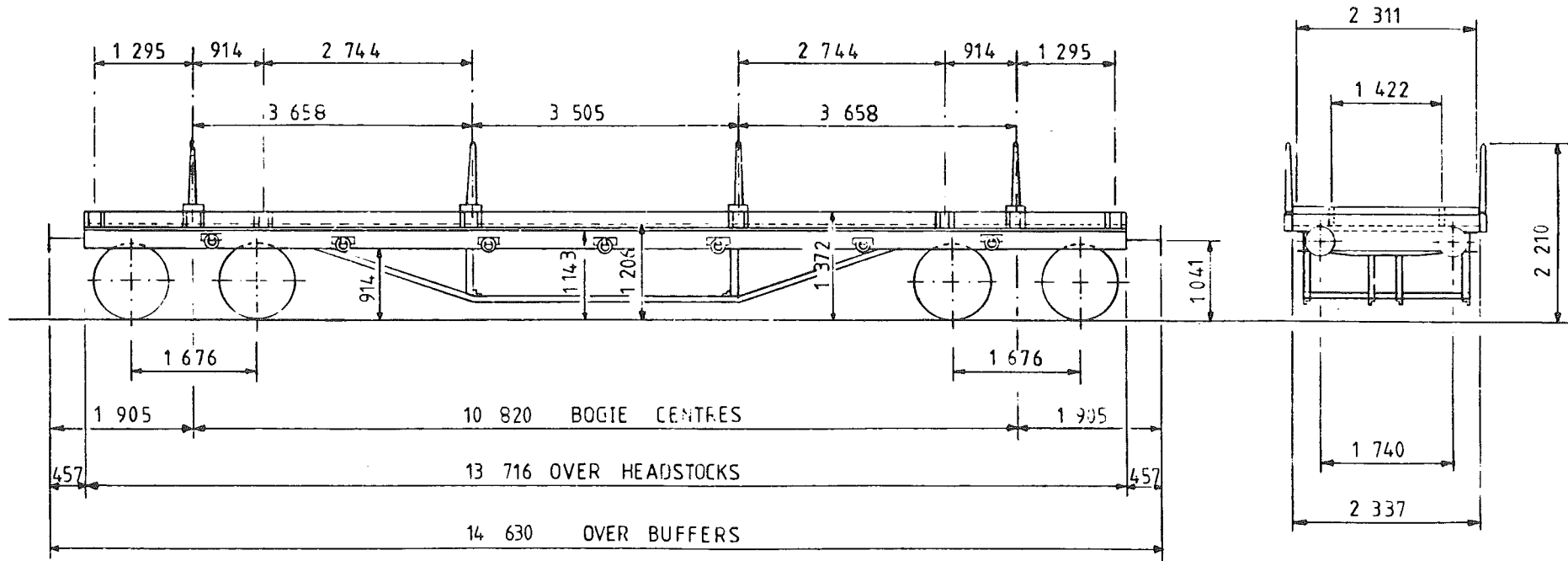

TARE -	15 500 kg
CAPACITY, WEIGHT -	30 500 kg
CAPACITY, VOLUME -	—
MIN. CURVE -	30 m
GEN. ARRGT. DRG. NO. -	49281 ^A

BRAKE -	HAND LEVER
SUSPENSION -	SECONDARY COIL
COUPLINGS -	INSTANTER
BUFFERS -	SELF CONTAINED 406x457 DIA HEADS
WHEELS -	952 DIA
JOURNALS -	114 x 203 (4 1/2" x 8") PLAIN BEARINGS

ISSUE 1

EX BR DIAGRAM B474

BOGIE BOLSTER WAGON

YN010B

LOT NUMBER	
2583	

TOPS INFORMATION										
AARKND		OPERATING		OPERATING SPEED			BRAKE FORCE DATA		EXCESS LENGTH	
CARKND		PANEL NO.		50 mile/h UP TO			NO POWER BRAKE			
Y	N	P	B	8	6	9				

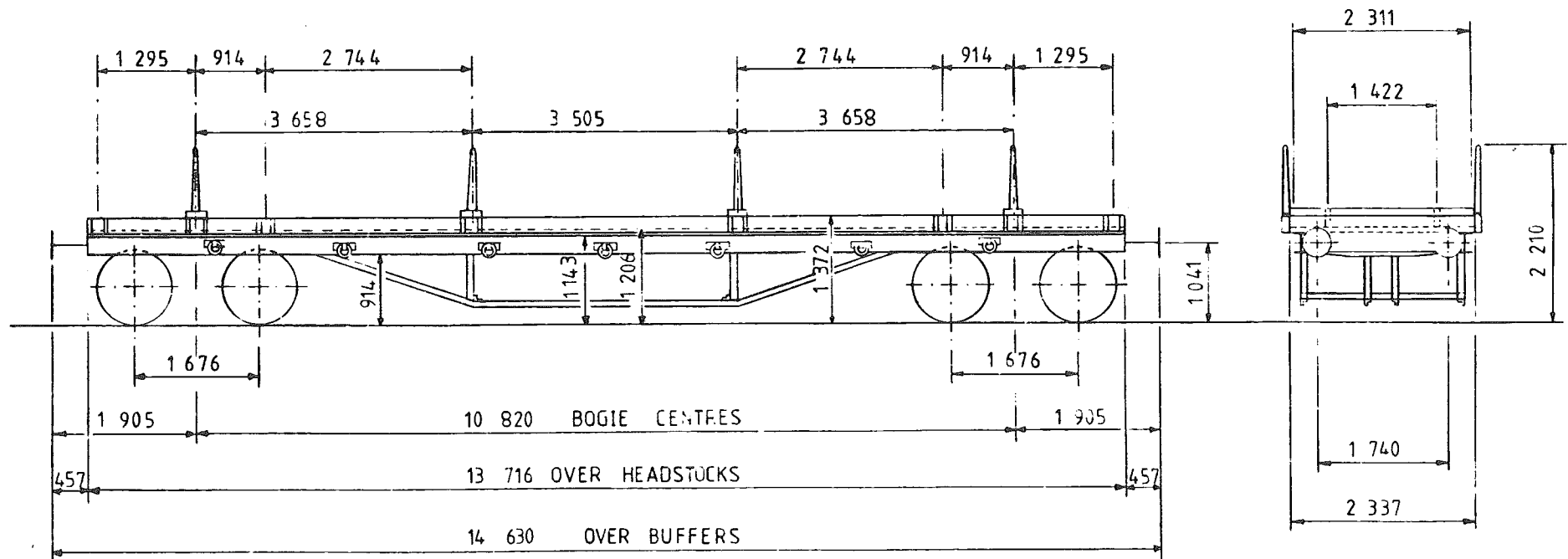

TARE -	15 ⁵⁰⁰ kg
CAPACITY, WEIGHT -	30 ⁵⁰⁰ kg
CAPACITY, VOLUME -	---
MIN. CURVE -	30 m
GEN ARRGT. DRG NO. -	49281 ^A

BRAKE -	HAND LEVER & VACUUM THRU PIPE
SUSPENSION -	SECONDARY COIL
COUPLINGS -	INSTANTER
BUFFERS -	SELF CONTAINED 406x457 DIA HEADS
WHEELS -	952 DIA
JOURNALS -	114 x 203 (4 1/2 x 8) PLAIN BEARINGS

ISSUE 1

EX. BR DIAGRAM B473

BOGIE RAIL WAGON

YN 011 B

LOT NUMBER	

TOPS INFORMATION						
AARKND	OPERATING	OPERATING SPEED		BRAKE FORCE DATA		EXCESS LENGTH 3
CARKND	PANEL NO.	50 mile/h UP TO		NO POWER BRAKE		
Y N O B	7 0 2 3	mile/h ABOVE		61 tonne GLW		

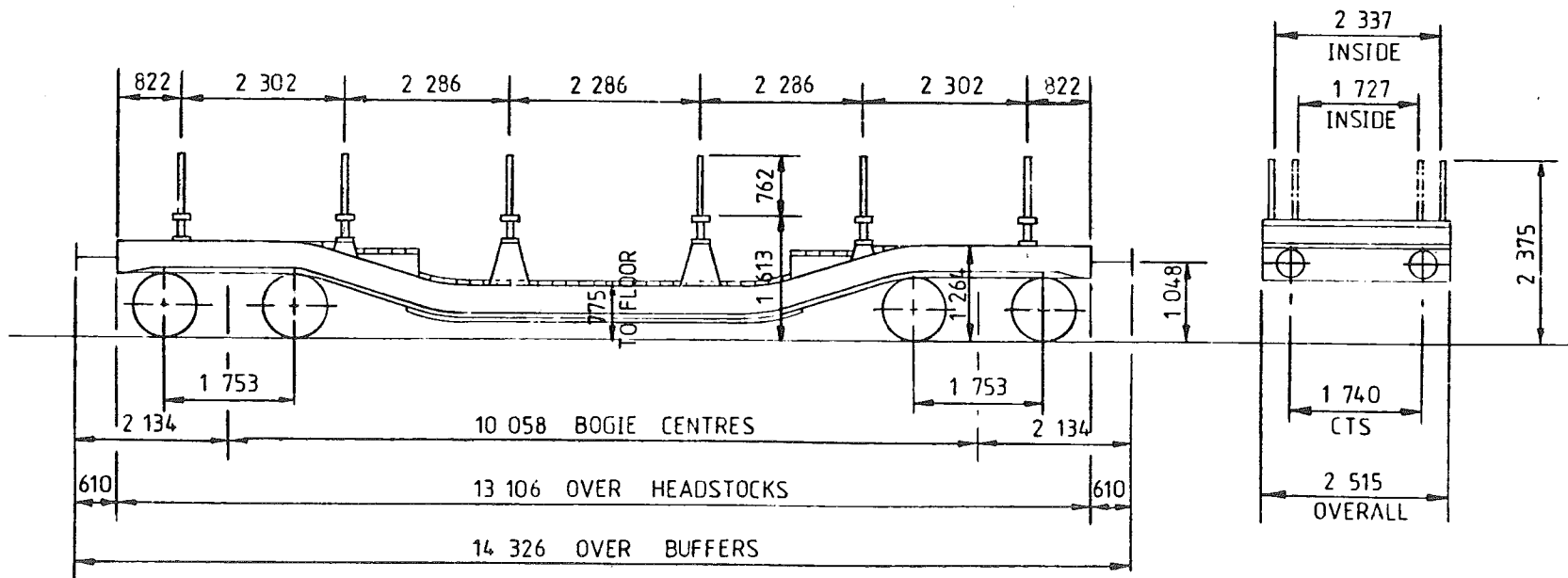

TARE -	30 850kg
CAPACITY, WEIGHT -	30 500kg
CAPACITY, VOLUME -	—
MIN. CURVE -	37m
GEN. ARRGT. DRG. NO. -	124356

BRAKE -	HAND SCREW
SUSPENSION -	SECONDARY COIL
COUPLINGS -	BR. SCREW
BUFFERS -	SELF CONTAINED, 400 DIA. HEADS
WHEELS -	838 DIA.
JOURNALS -	279x140(11"x5½") PLAIN BEARINGS

ISSUE 1

BOGIE BOLSTER WAGON

YN014B

LOT NUMBER	

TOPS INFORMATION					
AARKND	OPERATING	OPERATING SPEED		BRAKE FORCE DATA	EXCESS LENGTH
CARKND	PANEL NO.	45mile/h UP TO		NO POWER BRAKE	
Y N O B	8 7 4 3	mile/h ABOVE 61 tonne GLW			

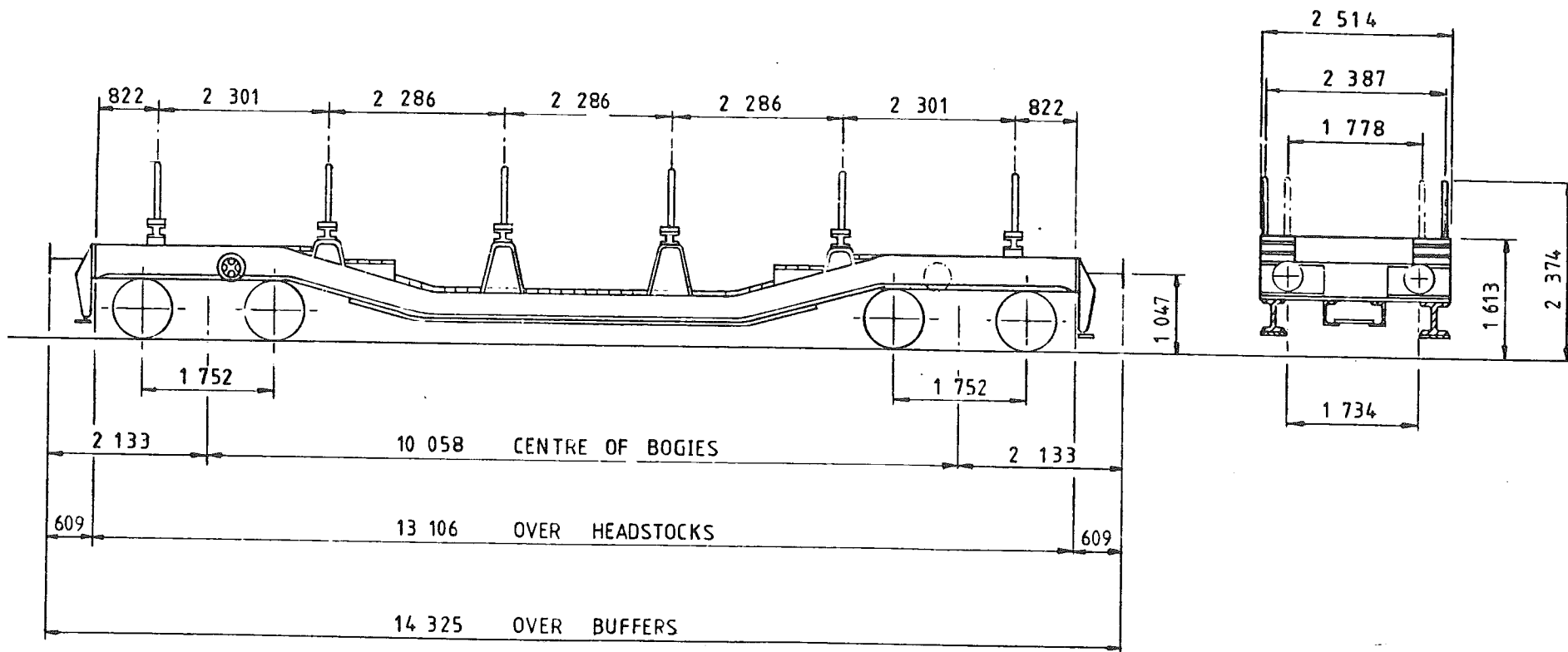

TARE -	30 ⁴⁵⁰ kg
CAPACITY, WEIGHT -	30 ⁵⁰⁰ kg
CAPACITY, VOLUME -	—
MIN. CURVE -	36.5m
GEN. ARRGT. DRG. NO. -	124356 ^A

BRAKE -	HAND SCREW
SUSPENSION -	SECONDARY COIL
COUPLINGS -	BR. SCREW
BUFFERS -	406x620 DIA HEADS
WHEELS -	838 DIA
JOURNALS -	280x140 (11x5 1/2) PLAIN BEARINGS

ISSUE 1

EX.LNER DIAGRAM E 212

BOGIE RAIL WAGON

YN 015 B

LOT NUMBER	

TOPS INFORMATION							
AARKND	OPERATING		OPERATING SPEED		BRAKE FORCE DATA		EXCESS LENGTH —
CARKND	PANEL NO.		45 mile/h UP TO		14t FORCE UP TO		
Y N V B	8	7	3	3	mile/h ABOVE 62 tonne GLW		

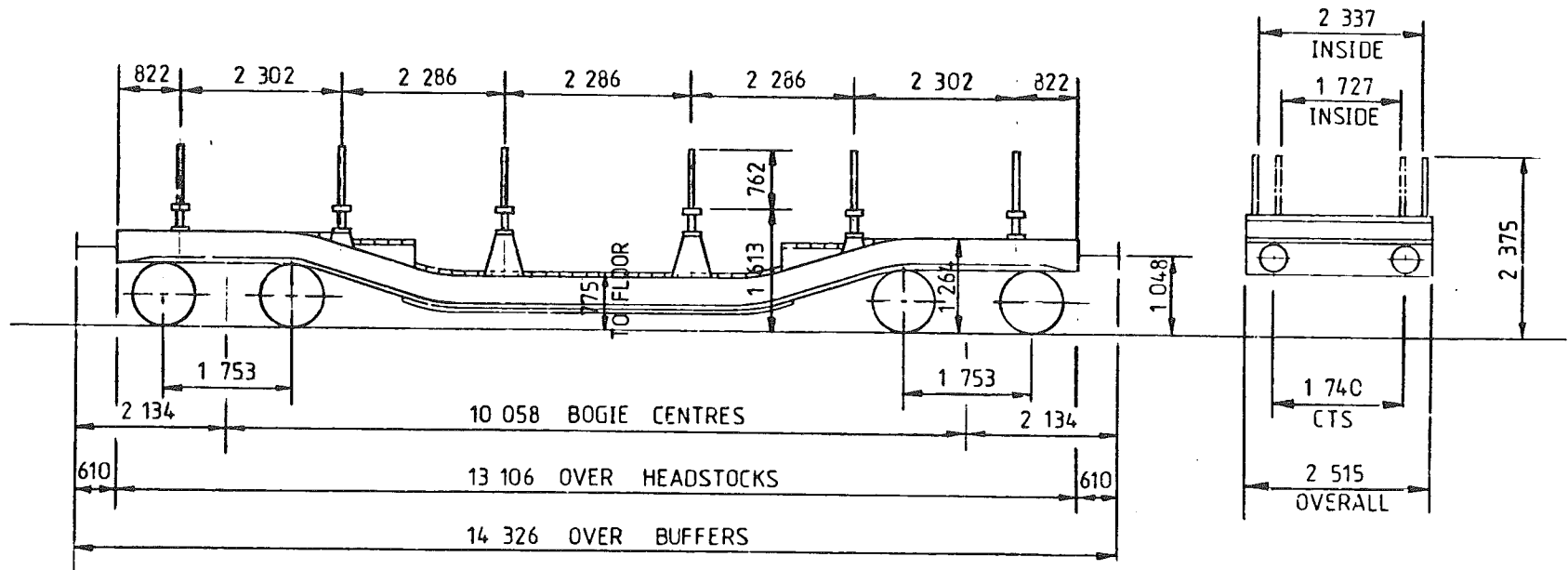

TARE -	30 850kg
CAPACITY, WEIGHT -	30 500kg
CAPACITY, VOLUME -	—
MIN. CURVE -	37m
GEN. ARRGT. DRG. NO. -	—

BRAKE -	VACUUM BLOCK & HAND SCREW
SUSPENSION -	SECONDARY COIL
COUPLINGS -	BR. SCREW
BUFFERS -	SELF CONTAINED, 400 DIA. HEADS
WHEELS -	838 DIA.
JOURNALS -	279x140(11"x5½") PLAIN BEARINGS

ISSUE 1

EX. G.W.R. DIAGRAM J 33

BOGIE BOLSTER WAGON

YNO18B

LOT NUMBER	

TOPS INFORMATION										
AARKND		OPERATING		OPERATING SPEED			BRAKE FORCE DATA		EXCESS LENGTH	
CARKND		PANEL NO.		45 mile/h UP TO			NO POWER BRAKE			
Y	N	P	B	8	7	0	8	-mile/h ABOVE 46 tonne GLW		

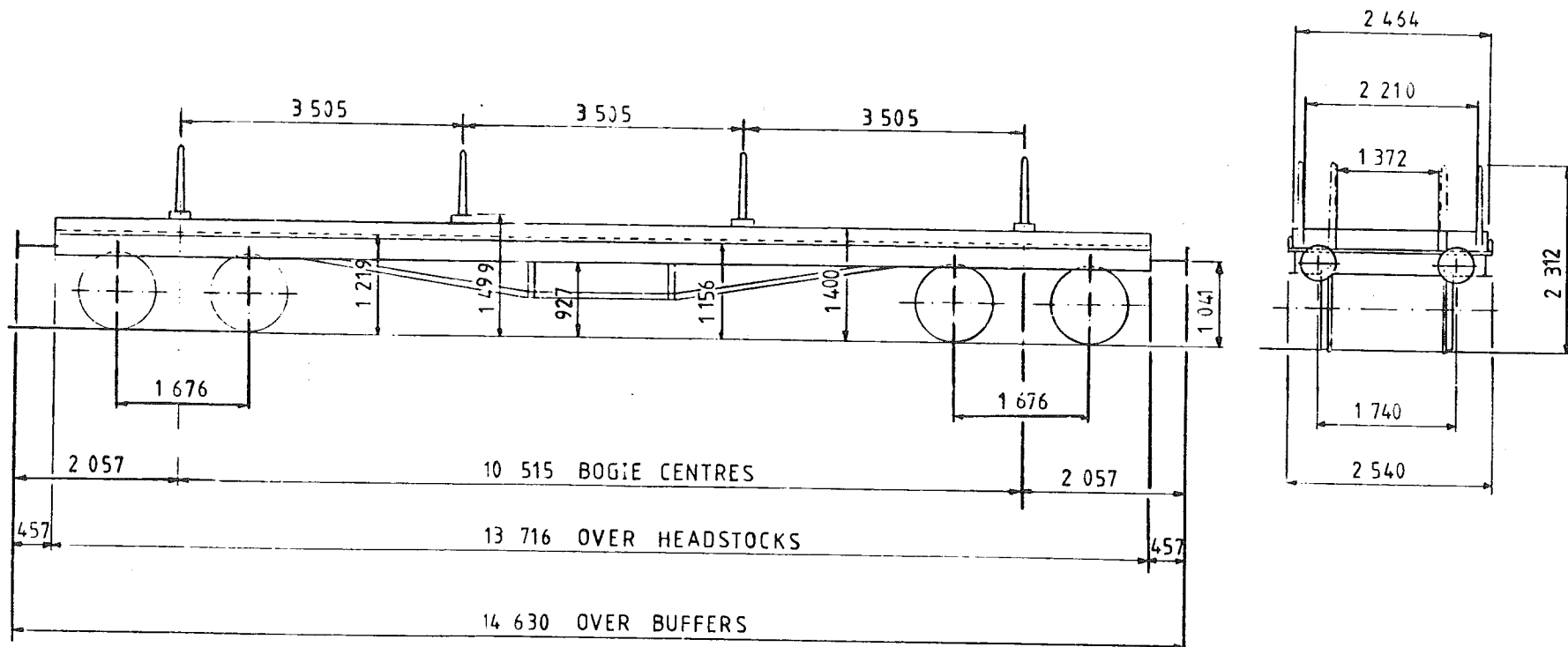

TARE -	14 630 Kg
CAPACITY, WEIGHT -	30 500 Kg
CAPACITY, VOLUME -	---
MIN. CURVE -	21m
GEN ARRGT. DRG. N ^o -	6468

BRAKE -	HAND LEVER & VACUUM TIRE PIPE
SUSPENSION -	SECONDARY COIL
COUPLINGS -	BR SCREW
BUFFERS -	SELF CONTAINED 457 DIA HEADS
WHEELS -	952 DIA
JOURNALS -	228 x 114 (9 x 4 1/2") PLAIN BEARINGS

ISSUE:

EX LMS SPECIAL DIAGRAM 11

BOGIE BOLSTER WAGON

YN021A

LOT NUMBER	

TOPS INFORMATION					
AARKND	OPERATING	OPERATING SPEED		BRAKE FORCE DATA	EXCESS LENGTH
CARKND	PANEL NO.	45mile/h UP TO		14 + FORCE UP TO	
Y N V E	8 7 4 6	mile/h ABOVE		+ FORCE ABOVE 61 tonne GLW	

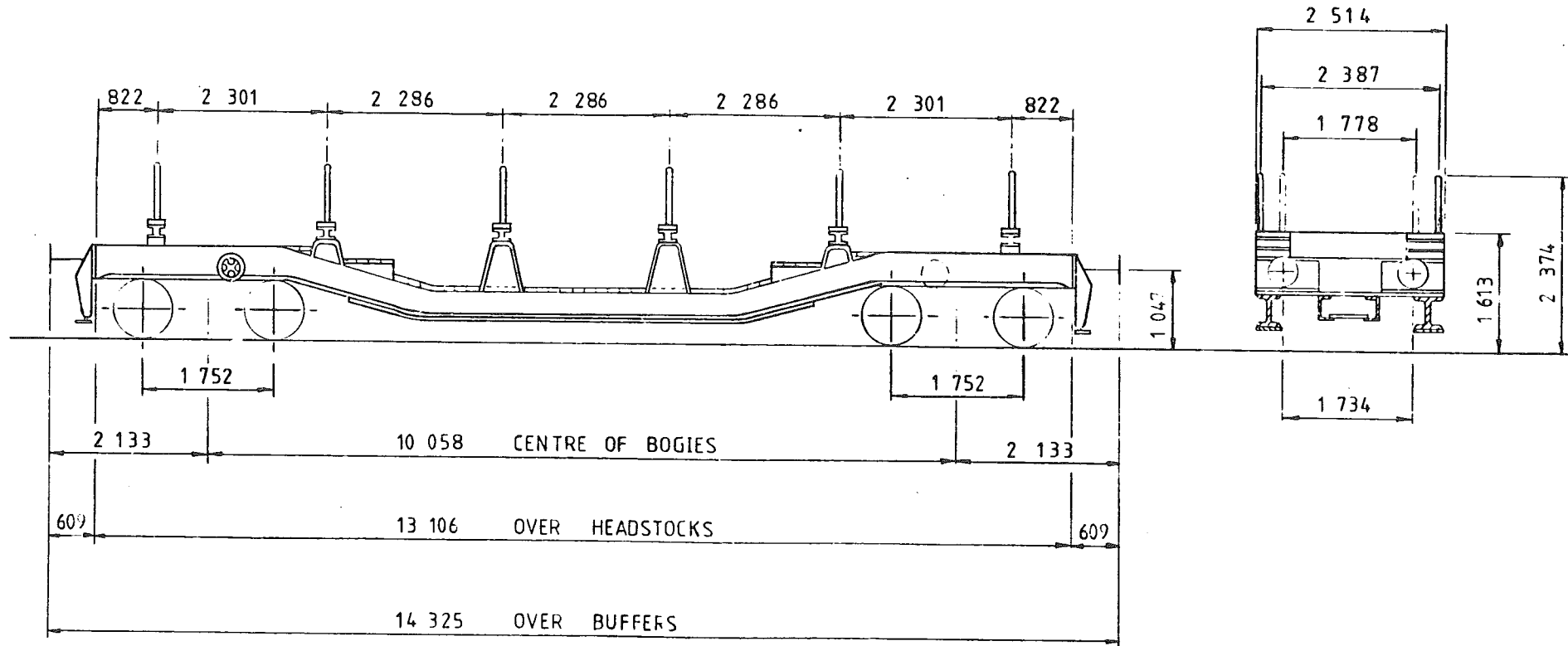

TARE -	30 ⁴⁵⁰ kg
CAPACITY, WEIGHT -	30 ⁵⁰⁰ kg
CAPACITY, VOLUME -	
MIN. CURVE -	36.5m
GEN. ARRGT. DRG. NO. -	124356 ^A

BRAKE -	VACUUM BRAKE & HAND SCREW
SUSPENSION -	SECONDARY COIL
COUPLINGS -	BR. SCREW
BUFFERS -	406x620 DIA HEADS
WHEELS -	838 DIA
JOURNALS -	280x140 (11x5 1/2) PLAIN BEARINGS

ISSUE 1

EXLNER DIAGRAM E 212

BOGIE BOLSTER WAGON — 'PRAWN'

YN 024 A

LOT NUMBER	
1469	

TOPS INFORMATION					
AARKND	OPERATING	OPERATING SPEED		BRAKE FORCE DATA	EXCESS LENGTH 3
CARKND	PANEL NO.	50 mile/h UP TO 45 tonne GLW		NO POWER BRAKE	
Y N O E	0 0 2 6	mile/h ABOVE			

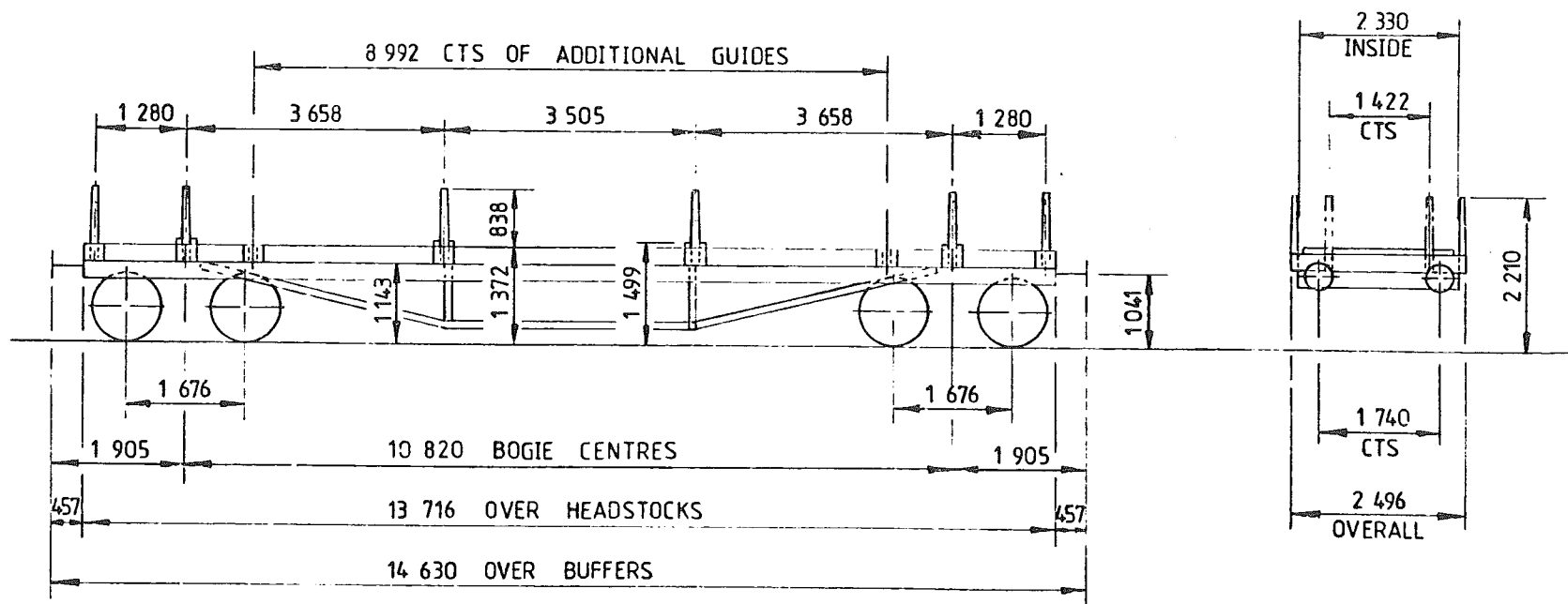

TARE -	15 ⁵⁵⁰ kg
CAPACITY, WEIGHT -	30 ⁵⁰⁰ kg
CAPACITY, VOLUME -	—
MIN. CURVE -	—
GEN. ARRGT. DRG. NO. -	—

BRAKE -	HAND LEVER
SUSPENSION -	SECONDARY COIL
COUPLINGS -	INSTANTER
BUFFERS -	SELF CONTAINED 406 DIA. HEADS
WHEELS -	953 DIA.
JOURNALS -	203x114 (8" x 4 1/2") PLAIN BEARINGS

ISSUE 1

EX GWR. DIAGRAM J 28

BOGIE BOLSTER WAGON

YN027B

LOT NUMBER	
1547	

TOPS INFORMATION						
AARKND	OPERATING	OPERATING SPEED		BRAKE FORCE DATA		EXCESS LENGTH
CARKND	PANEL NO.	45mile/h UP TO		11 t FORCE UP TO		
Y N V E	8 8 4 5	mile/h ABOVE 61tonne GLW		t FORCE ABOVE 61 tonne GLW		

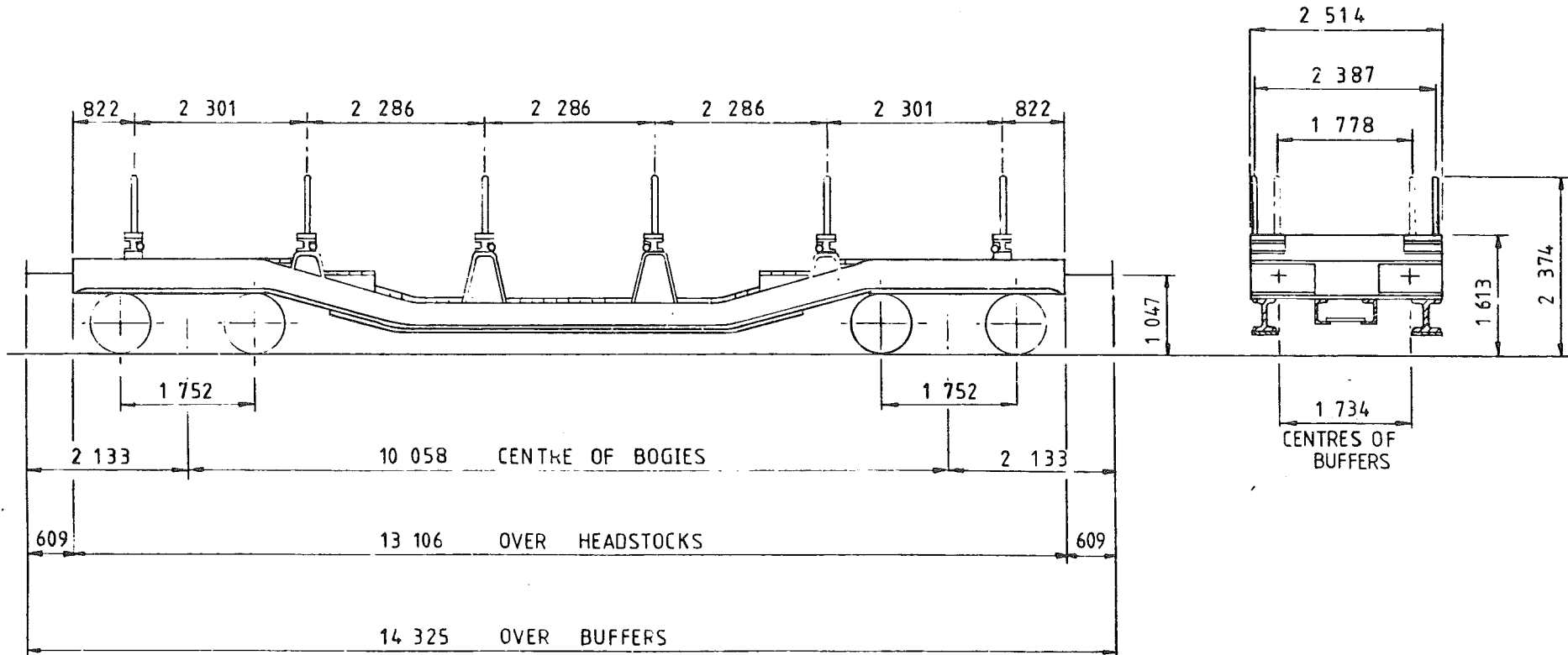

TARE -	29 ⁷⁰⁰ kg
CAPACITY, WEIGHT -	30 ⁵⁰⁰ kg
CAPACITY, VOLUME -	—
MIN. CURVE -	40m
GEN ARRGT. DRG N: -	13/4058

BRAKE -	HAND SCREW & VACUUM BRAKE
SUSPENSION -	SECONDARY COIL
COUPLINGS -	BR. SCREW
BUFFERS -	SELF CONTAINED (533x330) OVAL HEAD
WHEELS -	838 DIA
JOURNALS -	280x140 (11x5 1/2) PLAIN BEARINGS

ISSUE 1

EX LMS DIAGRAM Z/058

BOGIE BOLSTER WAGON - 'PRAWN'

YN 030 A

LOT NUMBER	
LMS	988

TOPS INFORMATION					
AARKND	OPERATING	OPERATING SPEED		BRAKE FORCE DATA	EXCESS LENGTH 11
CARKND	PANEL NO.	45 mile/h UP TO	56 tonne GLW	NO POWER BRAKE	
Y N O E	8 7 5 9	40 mile/h ABOVE			

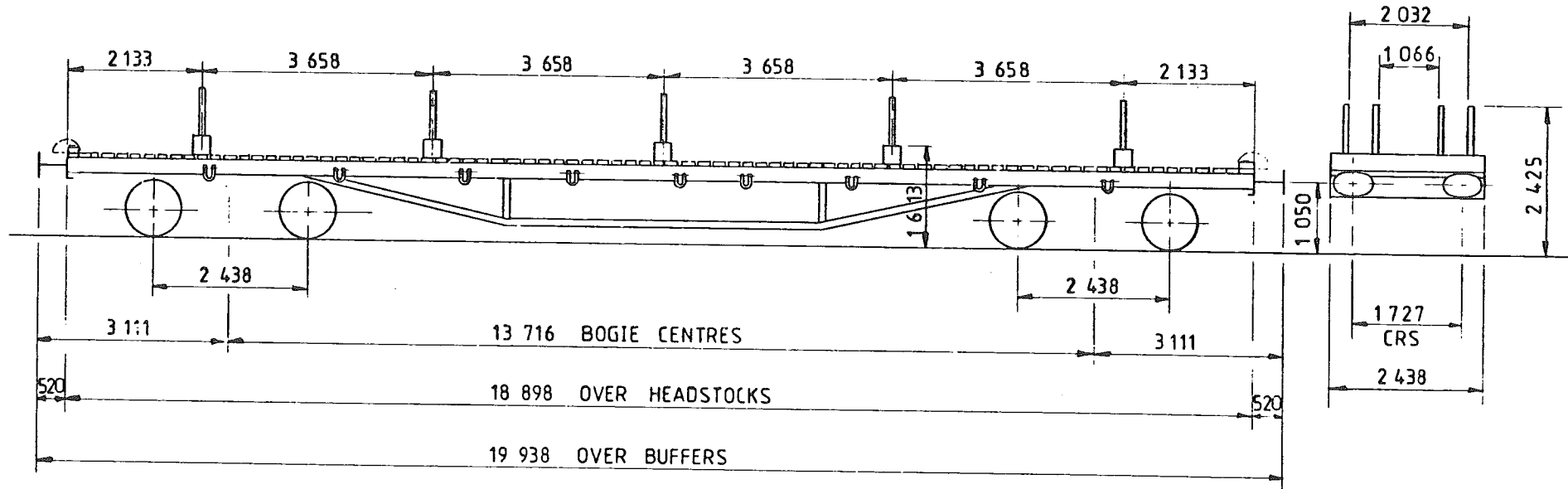

TARE -	24900kg
CAPACITY, WEIGHT -	51000kg
CAPACITY, VOLUME -	—
MIN. CURVE -	51 m
GEN ARRGT. DRG N ^o .	- 11/281

BRAKE -	HAND LEVER ON BOGIE
SUSPENSION -	EYEBOLT & RUBBERS
COUPLINGS -	BR SCREW
BUFFERS -	SELF CONTAINED 559x356 OVAL HEADS
WHEELS -	825 DIA.
JOURNALS -	280x140, (11x5 1/2) PLAIN BEARINGS

ISSUE 1

EX LMS DIAGRAM 19 B

BOGIE BOLSTER WAGON - 'PRAWN'

YN 031 A

LOT NUMBER	
LMS	1292

TOPS INFORMATION					
AARKND	OPERATING	OPERATING SPEED		BRAKE FORCE DATA	EXCESS LENGTH 11
CARKND	PANEL NO	45 mile/h UP TO		NO POWER BRAKE	
Y N O E	8 7 6 0	40 mile/h ABOVE			

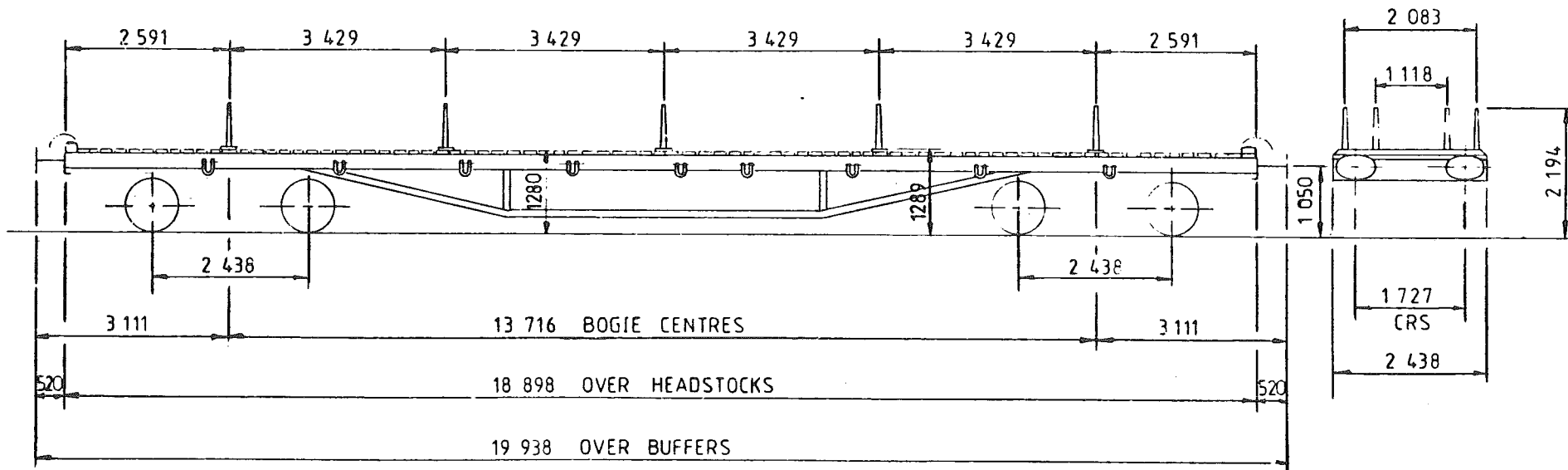

TARE -	23450 kg
CAPACITY, WEIGHT -	51000 kg
CAPACITY, VOLUME -	---
MIN CURVE -	51 m
GEN ARRGT DRG N ^o -	14/2945 & 11/427

BRAKE -	HAND LEVER ON BOGIE
SUSPENSION -	EYEBOLT & RUBBERS
COUPLINGS -	BR SCREW
BUFFERS -	SELF CONTAINED 559 x 356 OVAL HEADS
WHEELS -	825 DIA
JOURNALS -	230 x 140 (11 x 5 1/2) PLAIN BEARINGS

ISSUE 1

EX LMS DIAGRAM 19 E

BOGIE PLATE WAGON - 'WHELK'

YN 034 A

LOT NUMBER	
2010	2618
2455	2852
3046	

TOPS INFORMATION							
AARKND		OPERATING		OPERATING SPEED		BRAKE FORCE DATA	EXCESS LENGTH
CARKND		PANEL NO.		50 mile/h UP TO		NO POWER BRAKE	7
Y	N	O	G	0	0	4	0
				58 tonne GLW mile/h ABOVE			

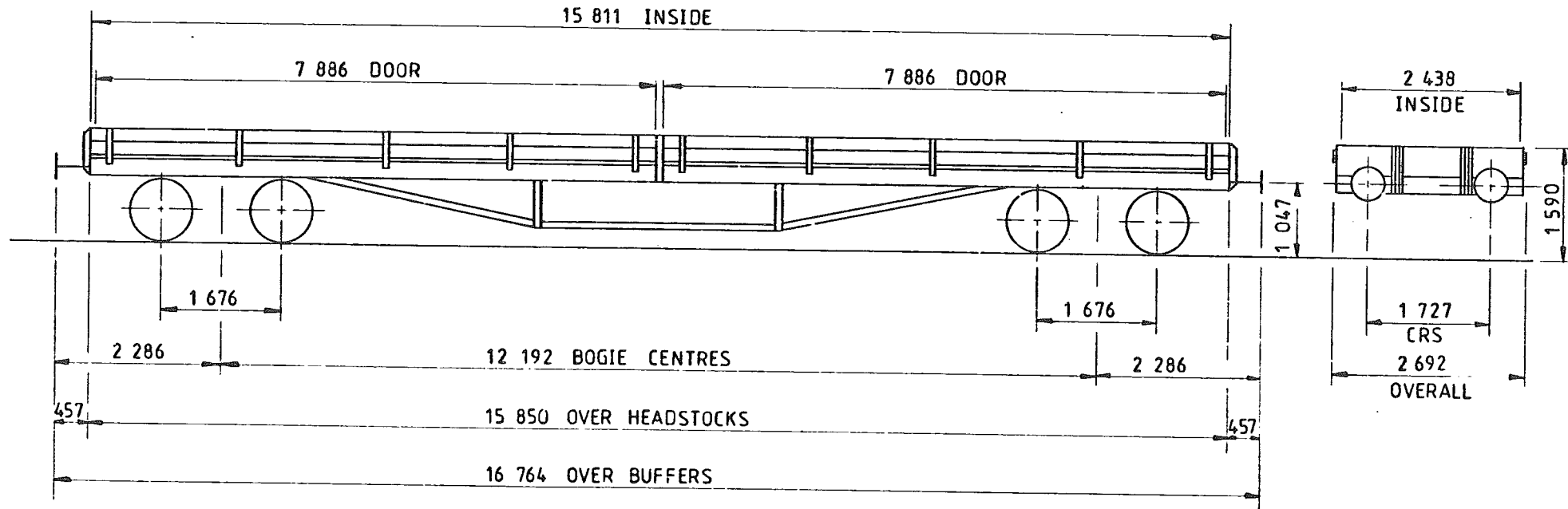

TARE -	18 600 kg
CAPACITY, WEIGHT -	42 500 kg
CAPACITY, VOLUME -	38 500 m ³
MIN. CURVE -	22 m
GEN. ARRGT. DRG. N ^o .	12/726 & 12/963

BRAKE -	HAND LEVER
SUSPENSION -	SECONDARY COIL
COUPLINGS -	INSTANTER
BUFFERS -	SPINDLE, 457 DIA. HEADS
WHEELS -	952 DIA.
JOURNALS -	254 x 127 (10 x 5) PLAIN BEARINGS

ISSUE 1

EX. BR. DIAGRAM 490

BOGIE PLATE WAGON - 'WHELK'

YN 035 A

LOT NUMBER	
2133	

TOPS INFORMATION					
AARKND	OPERATING	OPERATING SPEED		BRAKE FORCE DATA	EXCESS LENGTH 7
CARKND	PANEL NO.	50 mile/h UP TO		NO POWER BRAKE	
Y N O G	0 0 4 0	58 tonne GLW mile/h ABOVE			

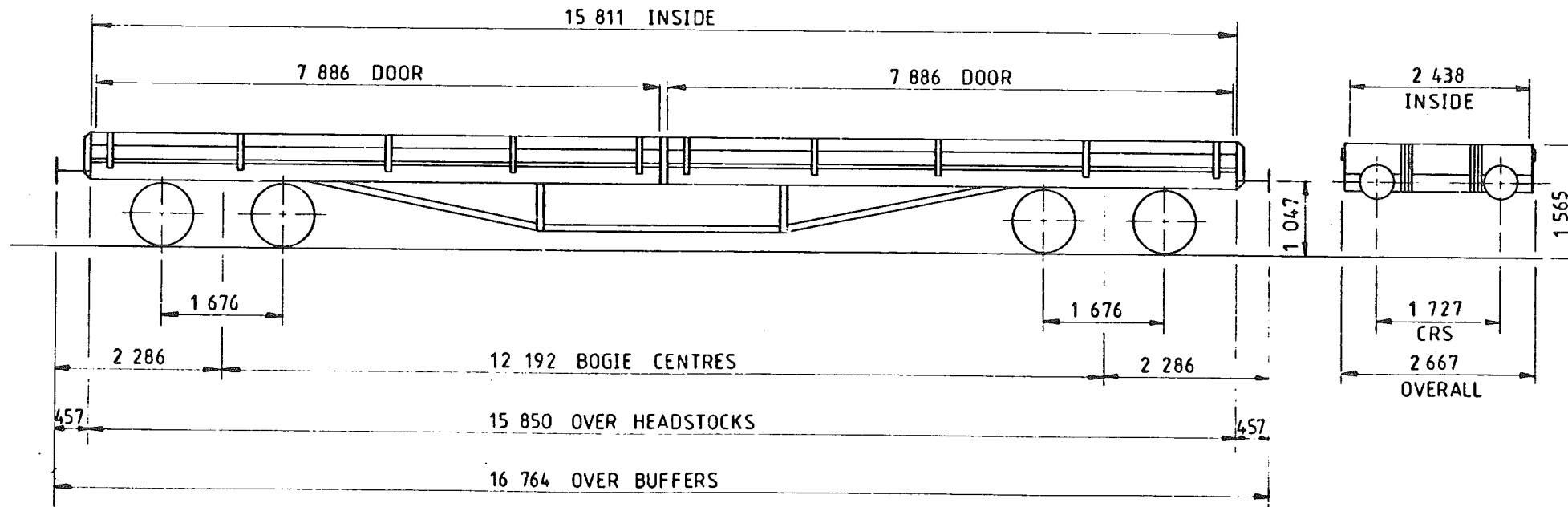

TARE -	19 500 kg
CAPACITY, WEIGHT -	42 500 kg
CAPACITY, VOLUME -	38 500 m ³
MIN. CURVE -	22 m
GEN. ARRGT. DRG. N ^o -	13744 D
	BOGIE - 8139 D

BRAKE -	HAND LEVER
SUSPENSION -	SECONDARY COIL
COUPLINGS -	INSTANTER
BUFFERS -	SPINDLE, 457 DIA. HEADS
WHEELS -	952 DIA.
JOURNALS -	254 x 127 (10" x 5") PLAIN BEARINGS

ISSUE 1

EX BR. DIAGRAM 491

BOGIE PLATE WAGON

YN037A

LOT NUMBER	

TOPS INFORMATION										
AARKND		OPERATING		OPERATING SPEED				BRAKE FORCE DATA		EXCESS LENGTH
CARKND		PANEL NO.		50mile/h UP TO				NO POWER BRAKE		
Y	N	O	G	8	7	4	7			

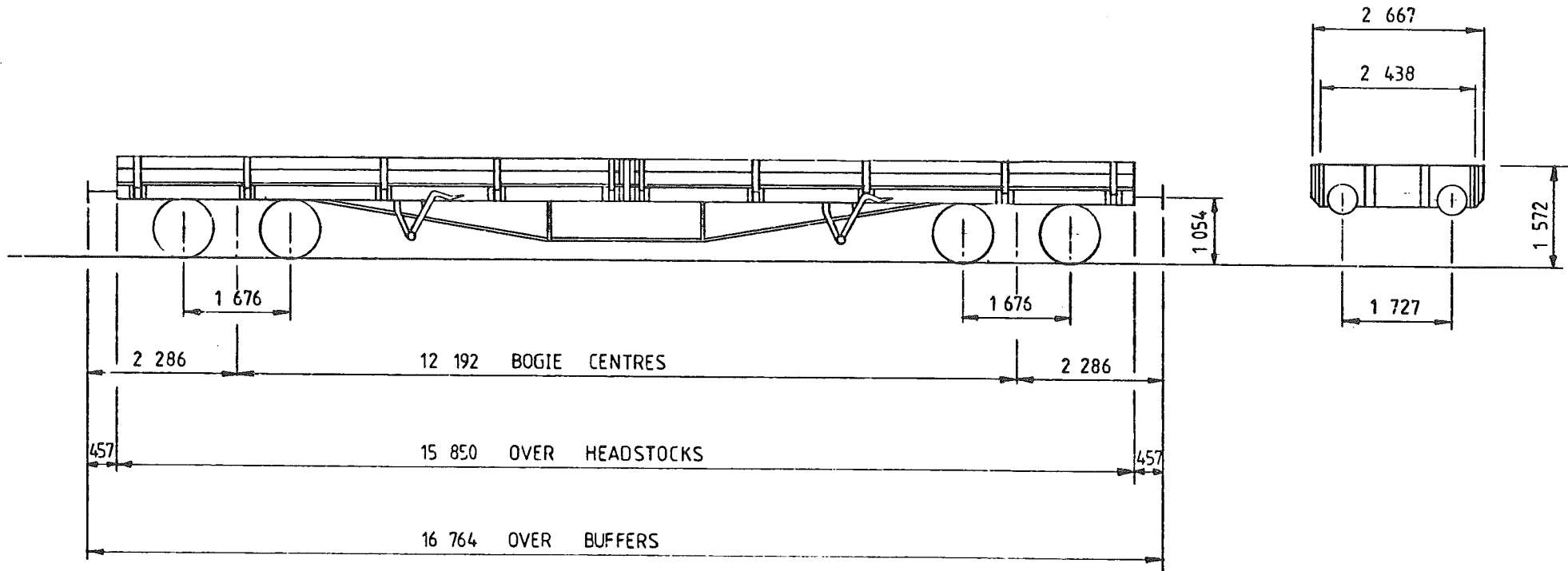

TARE -	19 ⁶⁰⁰ kg
CAPACITY, WEIGHT -	42 ⁵⁰⁰ kg
CAPACITY, VOLUME -	—
MIN. CURVE -	—
GEN. ARRGT. DRG. N ^o . -	—

BRAKE -	HAND LEVER
SUSPENSION -	—
COUPLINGS -	INSTANTER
BUFFERS -	SPINDLE 457 DIA HEADS
WHEELS -	952 DIA
JOURNALS -	254x127 (10x5) PLAIN BEARINGS

ISSUE 1

EXLNER DIAGRAM 68

BOGIE PLATE WAGON

YN038A

LOT NUMBER	
1422	

TOPS INFORMATION								
AARKND		OPERATING		OPERATING SPEED		BRAKE FORCE DATA		EXCESS LENGTH 7
CARKND		PANEL NO.		50 mile/h UP TO		NO POWER BRAKE		
Y	N	O	G	7	0	2	4	
				mile/h ABOVE		62 tonne GLW		

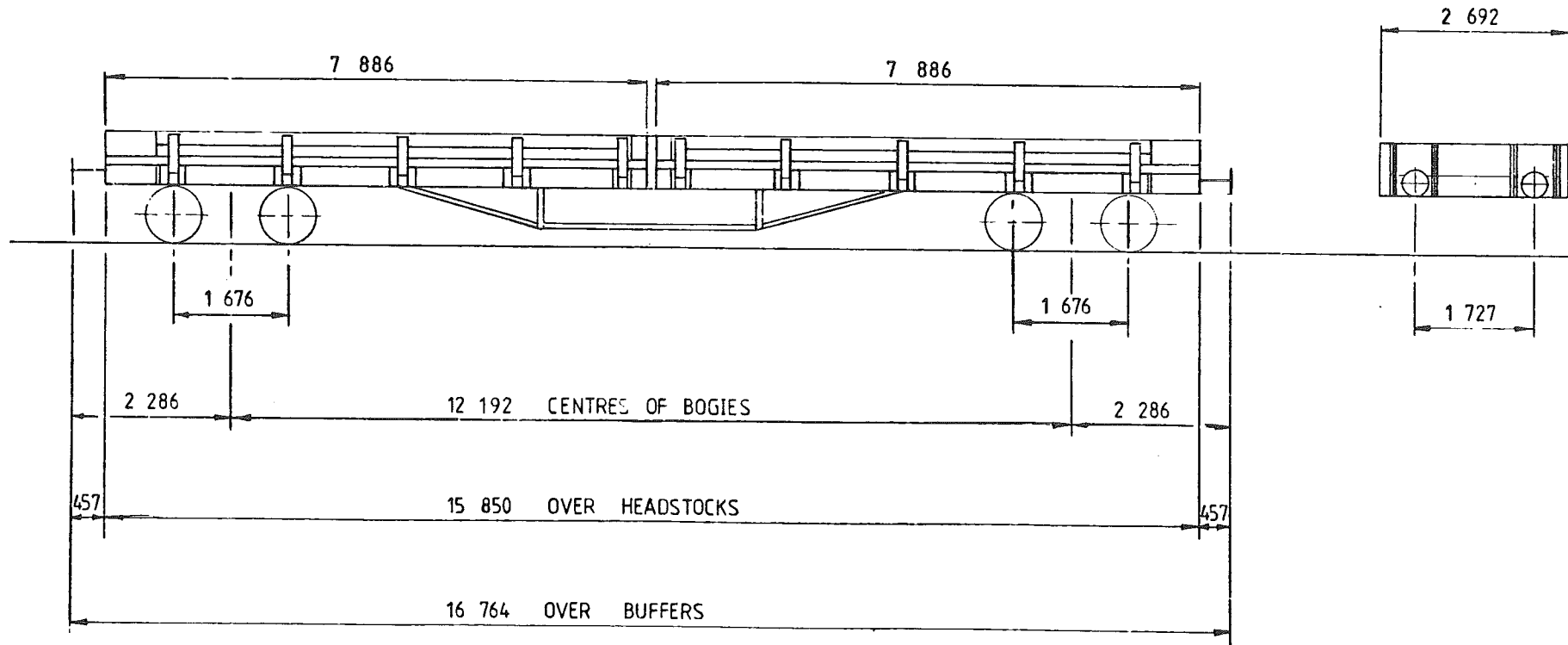

TARE -	19 ¹⁵⁰ kg
CAPACITY, WEIGHT -	42 ⁵⁰⁰ kg
CAPACITY, VOLUME -	—
MIN. CURVE -	21m
GEN. ARRGT. DRG. N ^o -	D12/726

BRAKE -	HAND LEVER
SUSPENSION -	SECONDARY COIL
COUPLINGS -	BR SCREW
BUFFERS -	SPINDLE (330x457) DIA HEADS
WHEELS -	825 DIA
JOURNALS -	254x127 (10x5)

ISSUE 1

EX. LMS DIAGRAM 2/188

BOGIE BOLSTER WAGON

YN 041 C

LOT NUMBER	
3104	
3113	

TOPS INFORMATION				
AARKND	OPERATING	OPERATING SPEED		EXCESS LENGTH
CARKND	PANEL NO.	55 mile/h UP TO 61 tonne GLW		7
Y	N	-mile/h ABOVE-		
V	C	0 1 5 5		

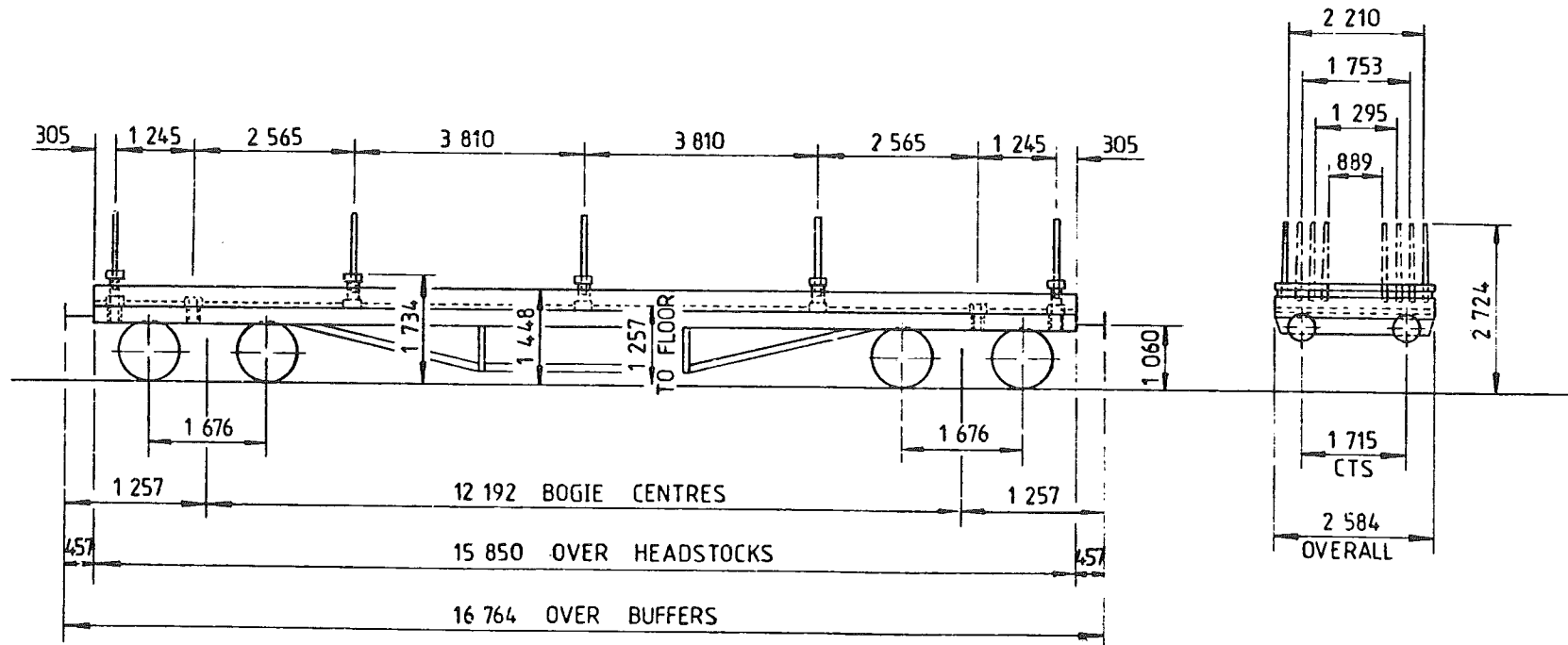

TARE -	22 ³⁰⁰ kg
CAPACITY, WEIGHT -	42 ⁷⁰⁰ kg
CAPACITY, VOLUME -	—
MIN. CURVE -	22m
GEN. ARRGT. DRG. NO. -	18533N

BRAKE -	VACUUM BLOCK & HAND LEVER
SUSPENSION -	SECONDARY COIL
COUPLINGS -	INSTANTER
BUFFERS -	SELF CONTAINED, 457 DIA HEADS
WHEELS -	953 DIA
JOURNALS -	254 x 127 (10" x 5") PLAIN BEARINGS

ISSUE 1

EX BR DIAGRAM 472

BOGIE BOLSTER WAGON

YN 043 B

LOT NUMBER	
2760	

TOPS INFORMATION							
AARKND	OPERATING		OPERATING SPEED		BRAKE FORCE DATA		EXCESS LENGTH 3
CARKND	PANEL NO.		50 mile/h UP TO		NO POWER BRAKE		
Y N P B	9 3 5 9	47.5 tonne GLW					

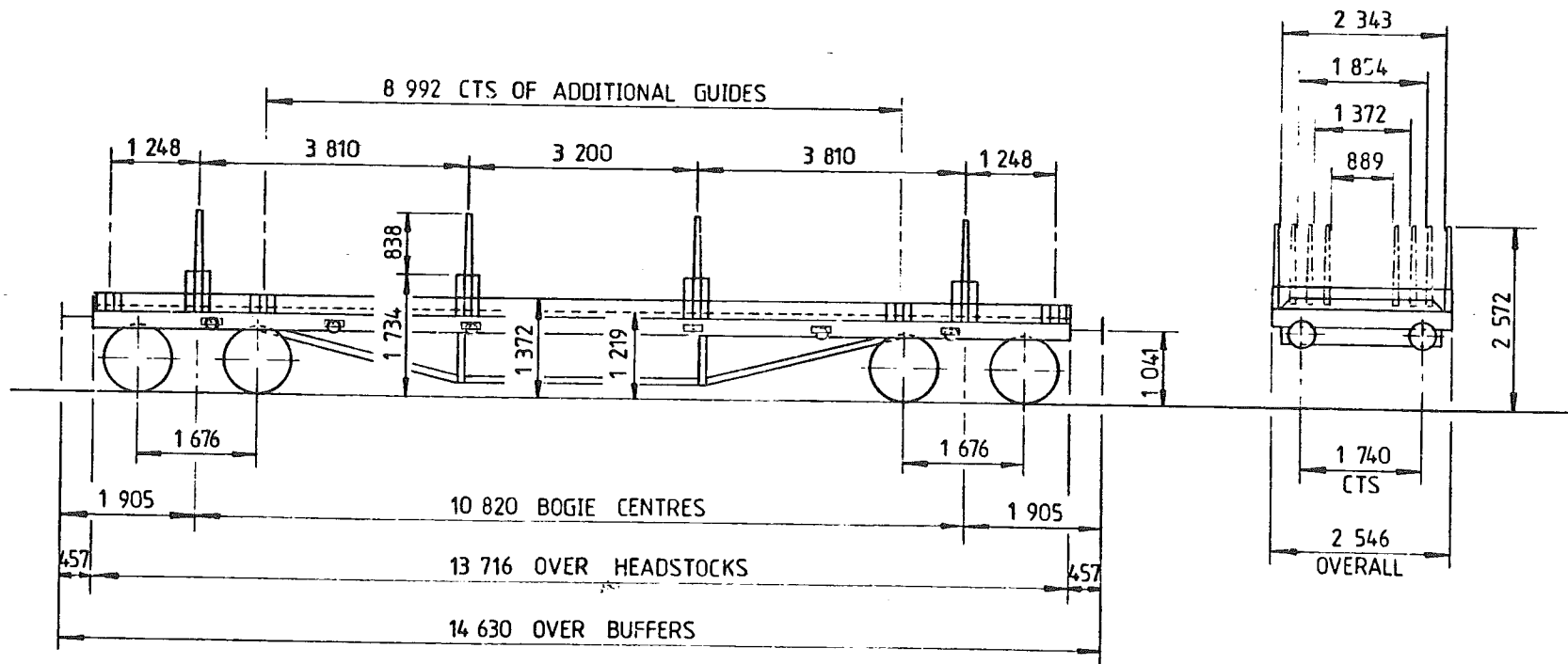

TARE -	17 ³⁵⁰ kg
CAPACITY, WEIGHT -	30 ⁵⁰⁰ kg
CAPACITY, VOLUME -	—
MIN. CURVE -	31m
GEN. ARRGT. DRG. NO. -	49281 F

BRAKE -	HAND LEVER & VACUUM PIPE
SUSPENSION -	SECONDARY COIL
COUPLINGS -	INSTANTER
BUFFERS -	SELF CONTAINED, 406 DIA HEADS
WHEELS -	953 DIA
JOURNALS -	229 x 114 (9" x 4 1/2") PLAIN BEARINGS

ISSUE 1

BOGIE STEEL CARRIER

YN044A

LOT NUMBER	
3896	

TOPS INFORMATION										
AARKND		OPERATING		OPERATING SPEED				BRAKE FORCE DATA		EXCESS LENGTH 11
CARKND		PANEL NO.		60mile/h UP TO 90tonne GLW				14t FORCE UP TO 90tonne GLW		
Y	N	B	D	8	6	8	0	50t FORCE ABOVE 90tonne GLW		

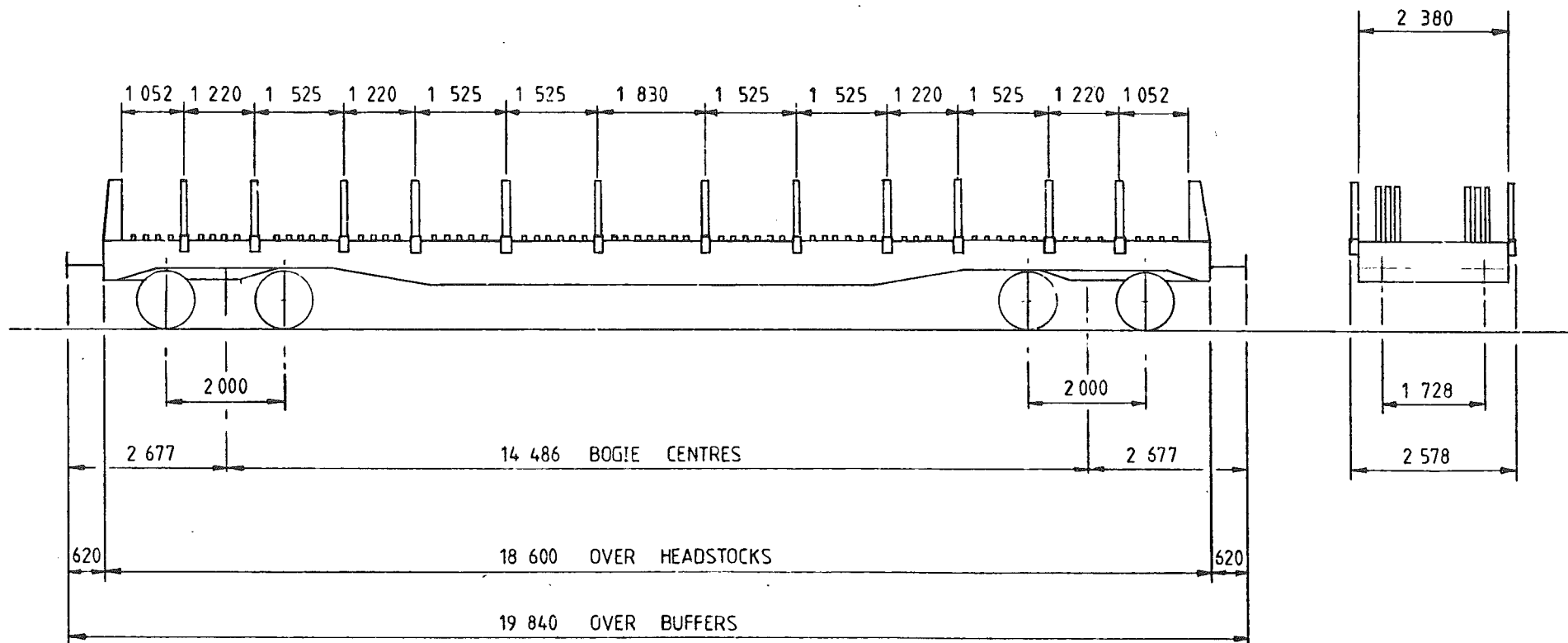

TARE -	32 ³⁵⁰ kg
CAPACITY, WEIGHT -	52 ⁵⁰⁰ kg
CAPACITY, VOLUME -	—————
MIN. CURVE -	50m SINGLY, 80m CLOSE COUPLED
GEN. ARRGT. DRG. NO. -	FS 13000

BRAKE -	AIR DISC & HAND SCREW
SUSPENSION -	PRIMARY COIL
COUPLINGS -	INT SCREW
BUFFERS -	(610x356) OVAL HEADS
WHEELS -	952 DIA
JOURNALS -	150 DIA ROLLER BEARINGS

ISSUE1

EX. BR. DIAGRAM521

BOGIE BOLSTER - 'SHRIMP'

YN 500 B

LOT NUMBER	
2497	

TOPS INFORMATION										
AARKND		OPERATING		OPERATING SPEED				BRAKE FORCE DATA		EXCESS LENGTH
CARKND		PANEL NO.		45 mile/h UP TO				NO POWER BRAKE		
Y	N	P	F	8	7	8	4			

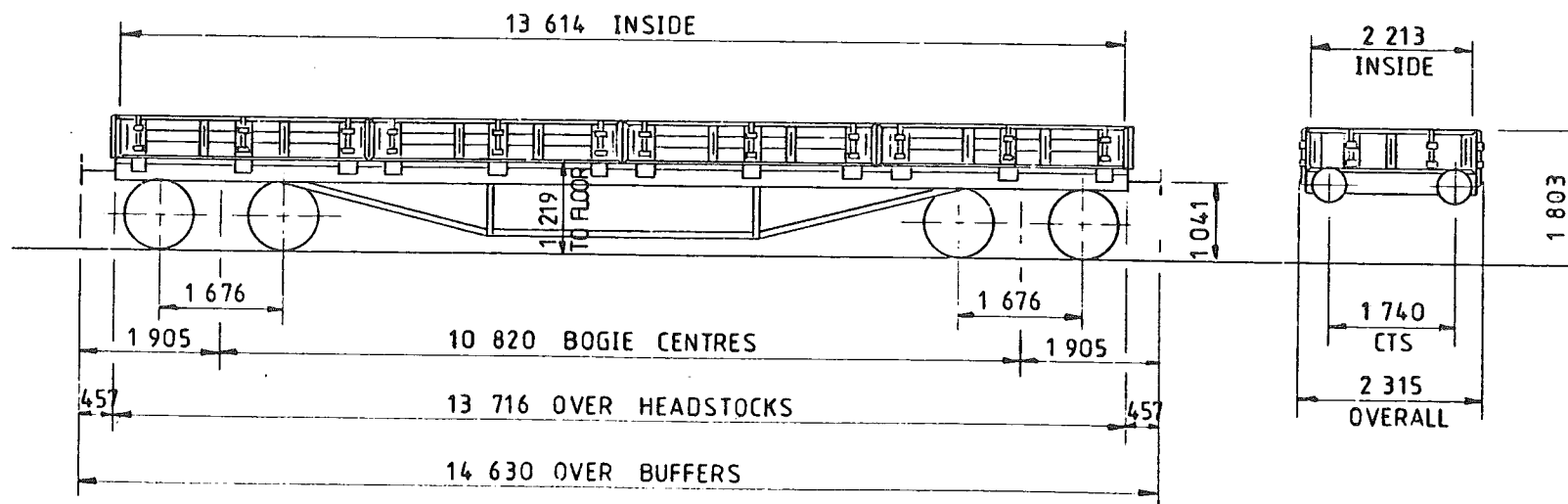

TARE -	18 000 kg
CAPACITY, WEIGHT -	30 500 kg
CAPACITY, VOLUME -	30 127 m ³
MIN. CURVE -	31 m
GEN. ARRGT. DRG. N ^o -	SW-ES-155
	BOGIE - SW-SW-71

BRAKE -	HAND LEVER & VACUUM THRO' PIPE
SUSPENSION -	SECONDARY COIL
COUPLINGS -	INSTANTER
BUFFERS -	SELF CONTAINED, 406 DIA. HEADS
WHEELS -	952 DIA.
JOURNALS -	228 x 114 (9" x 4 1/2") PLAIN BEARINGS

ISSUE 1

EX. BR. DIAGRAM 643

BOGIE BOLSTER WAGON

YN505E

LOT NUMBER	

TOPS INFORMATION										
AARKND		OPERATING		OPERATING SPEED			BRAKE FORCE DATA		EXCESS LENGTH	
CARKND		PANEL NO.		45mile/h UP TO			NO POWER BRAKE			
Y	N	R	C	8	7	2				

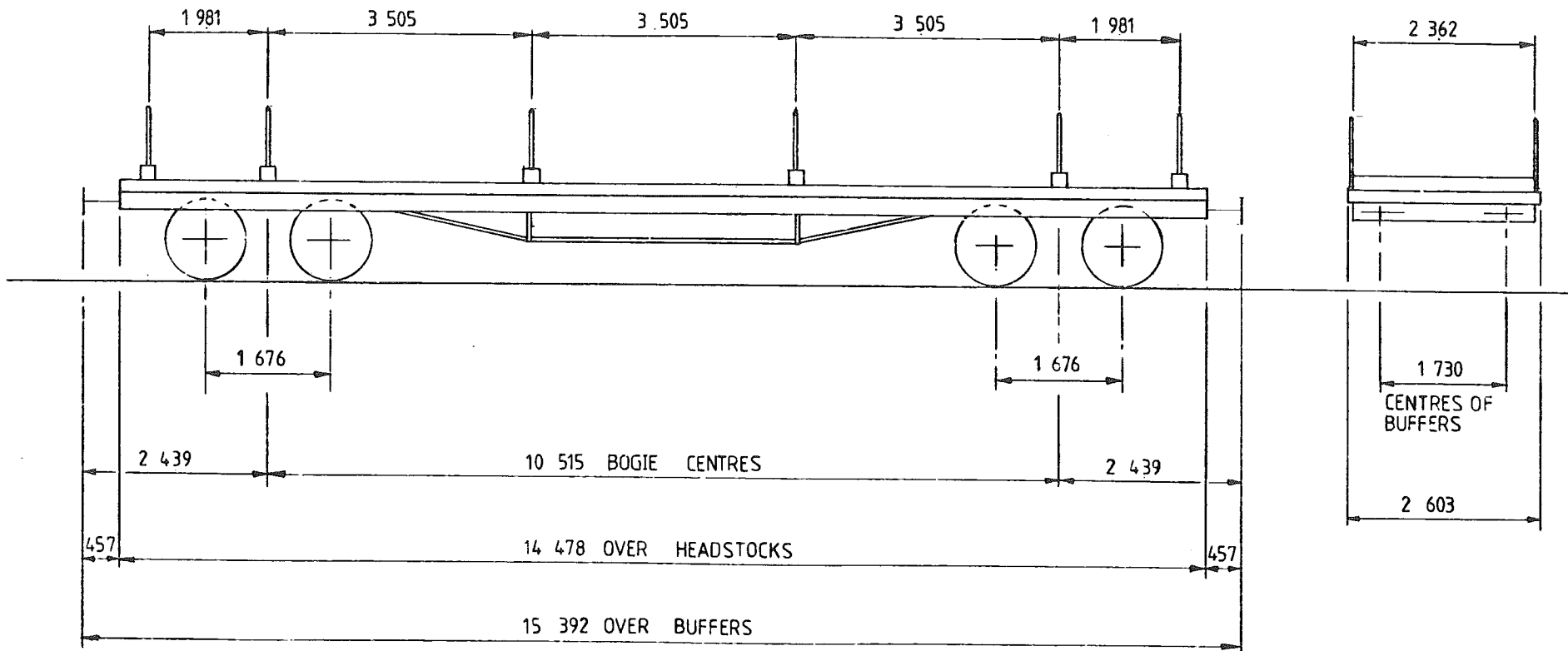

TARE -	18 ⁷⁵⁰ kg
CAPACITY, WEIGHT -	40 ⁵⁰⁰ kg
CAPACITY, VOLUME -	—
MIN. CURVE -	
GEN. ARRGT. DRG N ^o . -	

BRAKE -	DUAL 'THRO' PIPE & HAND SCREW
SUSPENSION -	SECONDARY COIL
COUPLINGS -	INSTANTER
BUFFERS -	SPINDLE (330x457) DIA HEADS
WHEELS -	
JOURNALS -	

ISSUE 1

EX. SR DIAGRAM 1597

BOGIE BOLSTER WAGON

YN507A

LOT NUMBER	
LMS	1497

TOPS INFORMATION								
AARKND		OPERATING		OPERATING SPEED		BRAKE FORCE DATA		EXCESS LENGTH
CARKND		PANEL NO.		45 mile/h UP TO		NO POWER BRAKE		
Y	N	O	B	8	7	2	7	

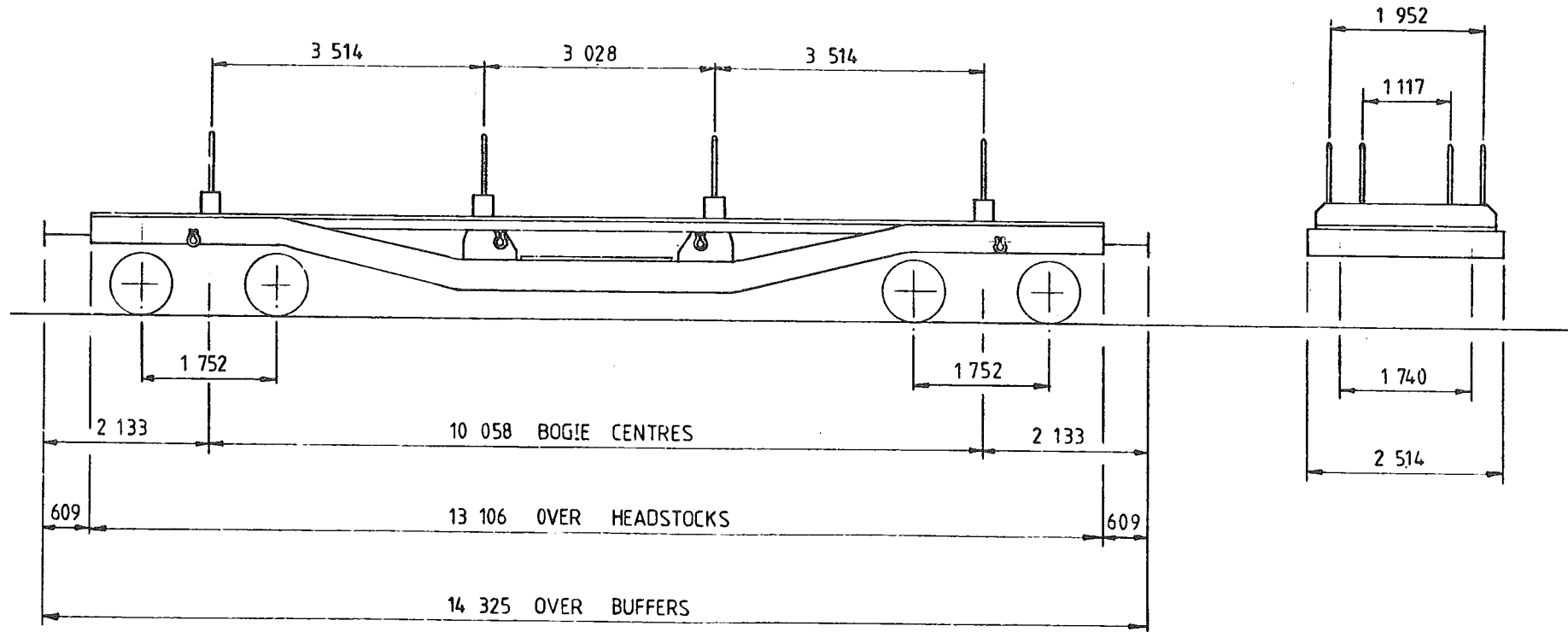

TARE -	29 ³⁰⁰ kg
CAPACITY, WEIGHT -	30 ⁵³⁰ kg
CAPACITY, VOLUME -	—
MIN. CURVE -	40m
GEN. ARRGT. DRG N ^o -	D14/4460

BRAKE -	HAND SCREW
SUSPENSION -	SECONDARY COIL
COUPLINGS -	BR SCREW
BUFFERS -	SELF CONTAINED (533x330) OVAL HEAD
WHEELS -	838 DIA
JOURNALS -	279x140 (11x5 1/2) PLAIN BEARINGS

ISSUE 1

EX. LMS DIAGRAM Z 110

BOGIE TRAVELLING CRANE

YO 002A

LOT NUMBER	

TOPS INFORMATION						
AARKND	OPERATING	OPERATING SPEED		BRAKE FORCE DATA		EXCESS LENGTH
CARKND	PANEL NO.	45 mile/h UP TO		+ FORCE UP TO-		
Y O P F	8 8 4 0	- mile/h ABOVE 45 tonne GLW		+ FORCE ABOVE tonne GLW		

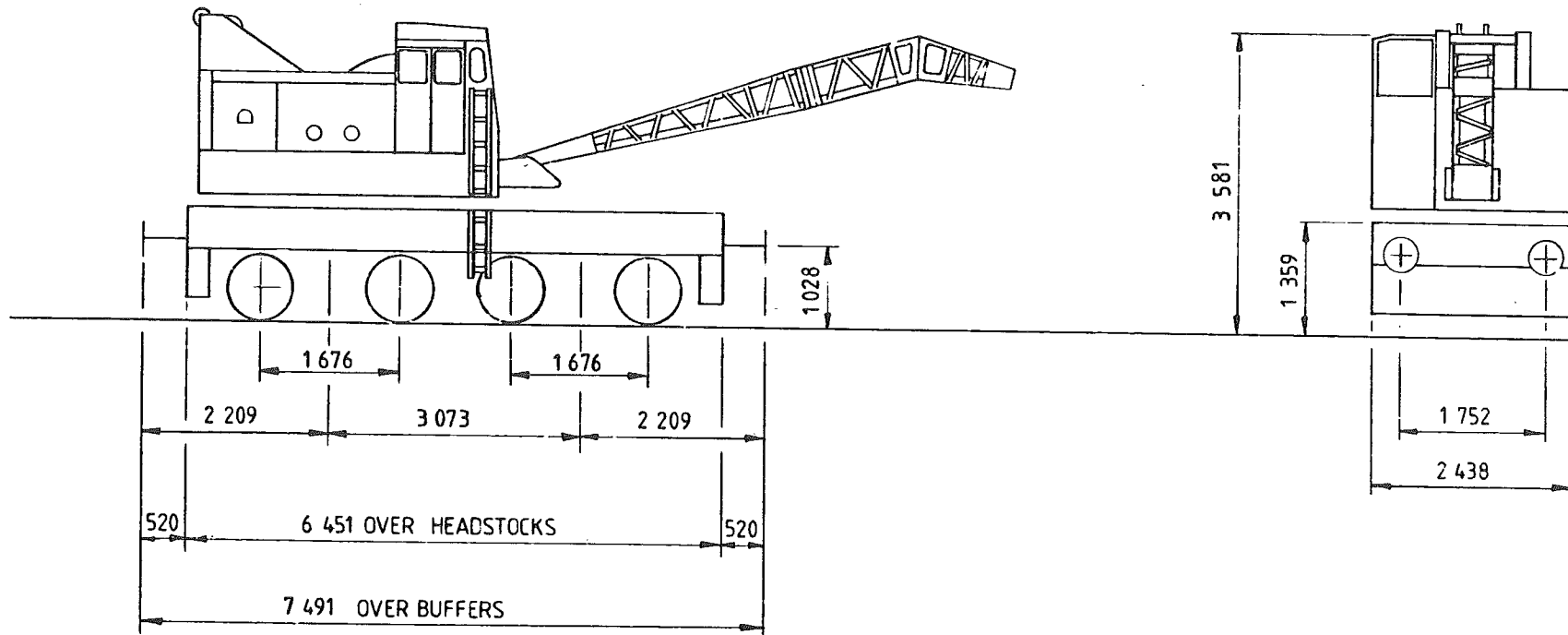

TARE -	44 ⁷⁰⁰ kg
CAPACITY, WEIGHT -	10 ⁰⁰⁰ kg
CAPACITY, VOLUME -	—
MIN. CURVE -	41m
GEN ARRGT DRG NO -	

BRAKE -	VAC PIPE & HAND SCREW
SUSPENSION -	SECONDARY COIL
COUPLINGS -	B.R. SCREW
BUFFERS -	SELF CONTAINED 406 DIA HEAD
WHEELS -	838 DIA
JOURNALS -	152 DIA (S) ROLLER BEARING

ISSUE 1

BOGIE TRAVELLING CRANE

YO 003A

LOT NUMBER	

TOPS INFORMATION													
AARKND		OPERATING		OPERATING SPEED				BRAKE FORCE DATA		EXCESS LENGTH			
CARKND		PANEL NO.		45 mile/h UP TO				+ FORCE UP TO-					
Y O P F		8 8 4 0		- mile/h ABOVE				44 tonne GLW			+ FORCE ABOVE		tonne GLW

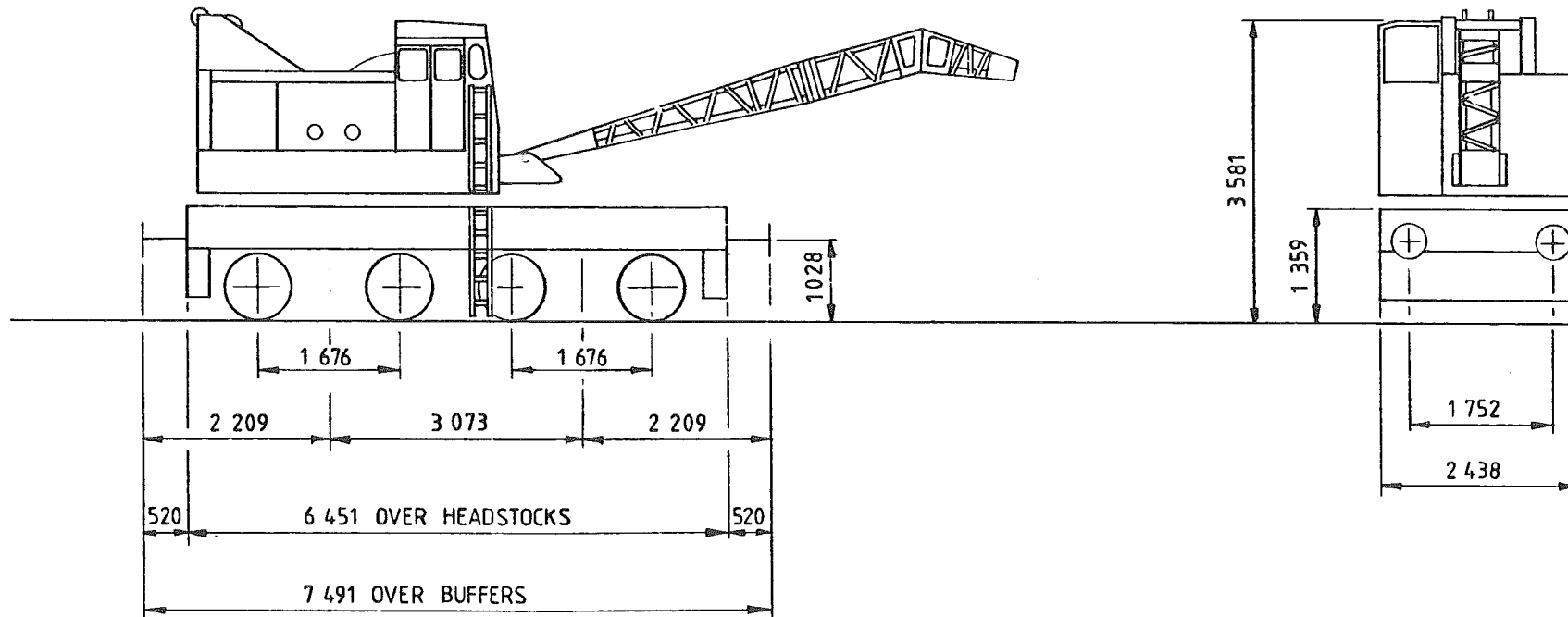

TARE -	43 ⁶⁵⁰ kg
CAPACITY, WEIGHT -	10 ⁰⁰⁰ kg
CAPACITY, VOLUME -	—
MIN. CURVE -	41m
GEN ARRGT DRG N ^o -	

BRAKE -	VAC. PIPE & HAND SCREW
SUSPENSION -	SECONDARY COIL
COUPLINGS -	B.R. SCREW
BUFFERS -	SELF CONTAINED 406 DIA HEAD
WHEELS -	838 DIA
JOURNALS -	152 DIA (6) ROLLER BEARING

ISSUE 1

EX BR DIAGRAM U194

BOGIE TRAVELLING CRANE

YO 003B

LOT NUMBER	

TOPS INFORMATION						
AARKND	OPERATING	OPERATING SPEED		BRAKE FORCE DATA		EXCESS LENGTH
CARKND	PANEL NO.	45 mile/h UP TO	65 tonne GLW	† FORCE UP TO	tonne GLW	
Y O P F	8 8 4 4	mile/h ABOVE		† FORCE ABOVE		

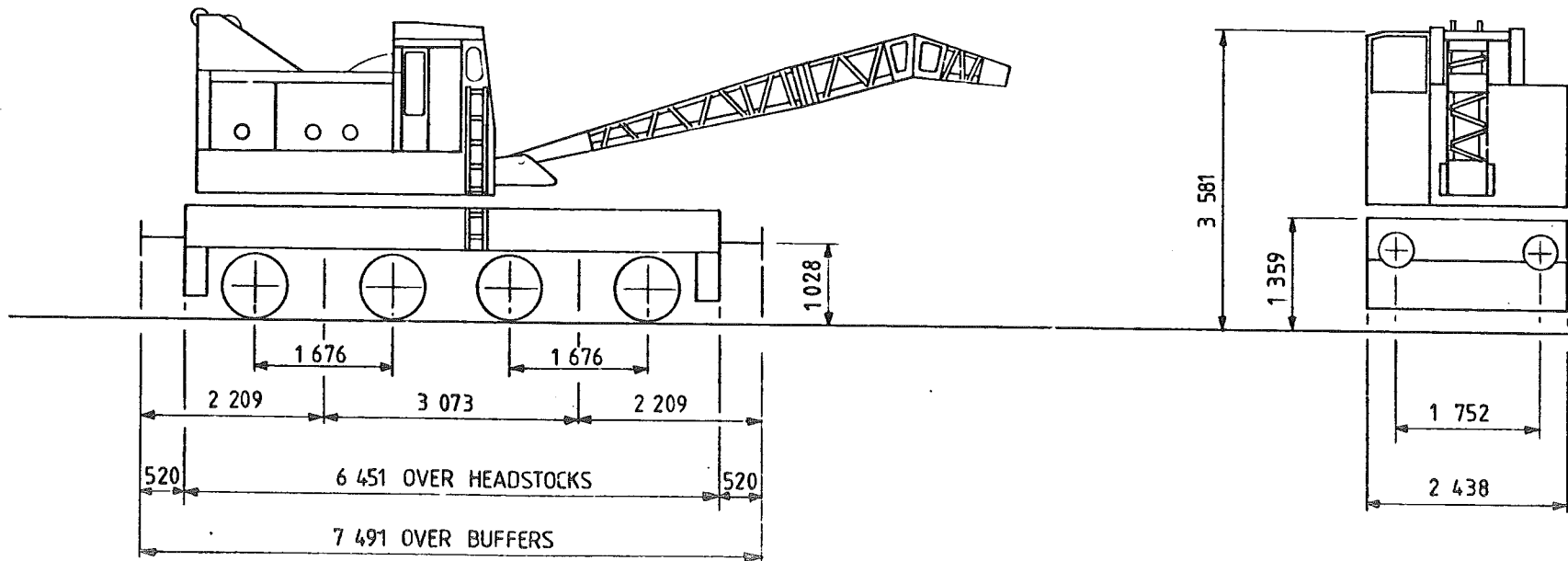

TARE -	64 ⁴⁰⁰ kg
CAPACITY, WEIGHT -	10 ⁰⁰⁰ kg
CAPACITY, VOLUME -	—
MIN. CURVE -	41m
GEN ARRGT. DRG N ^o . -	

BRAKE -	VAC. PIPE & HAND SCREW
SUSPENSION -	SECONDARY COIL
COUPLINGS -	B.R. SCREW
BUFFERS -	SELF CONTAINED 406 DIA HEAD
WHEELS -	762 DIA
JOURNALS -	152 DIA (6) ROLLER BEARING

ISSUE1

BOGIE TRAVELLING CRANE

YO005A

LOT NUMBER	

TOPS INFORMATION						
AARKND	OPERATING		OPERATING SPEED		BRAKE FORCE DATA	EXCESS LENGTH
CARKND	PANEL NO.		45mile/h UP TO			
Y O P F	8	8	3	8	49 tonne GLW	tonne GLW
					† FORCE UP TO	
					† FORCE ABOVE	

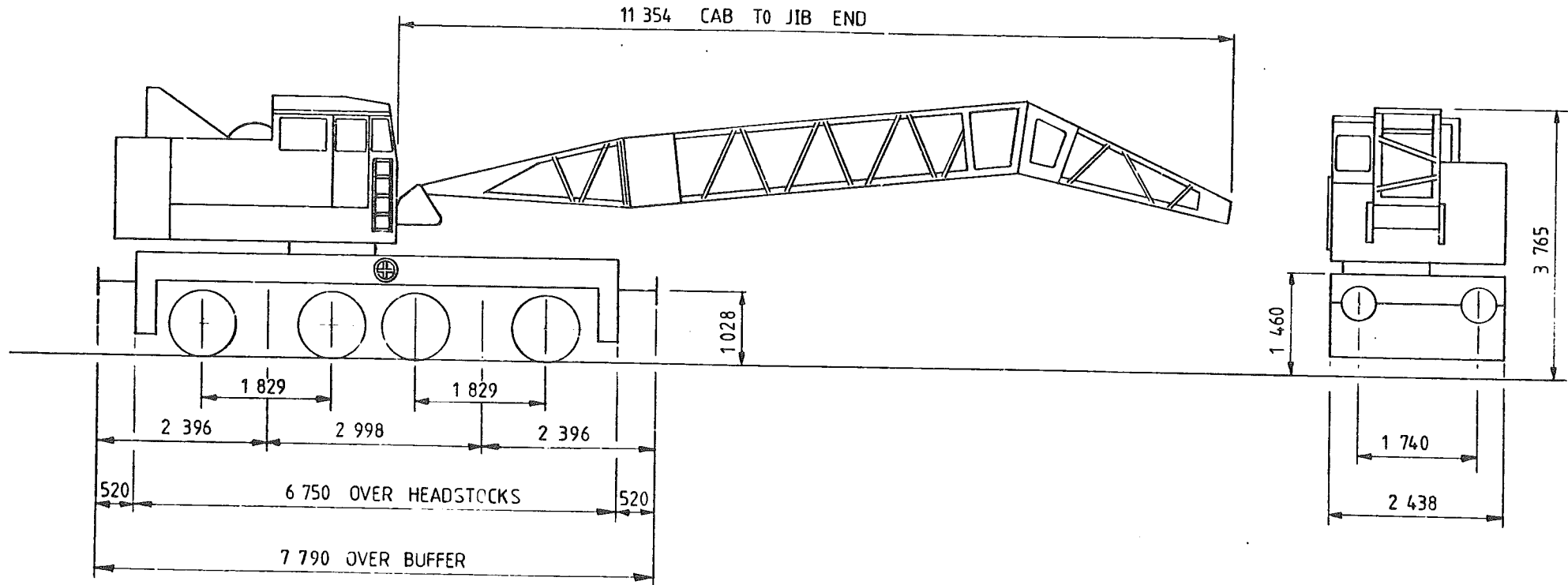

TARE -	49 ⁰⁰⁰ kg
CAPACITY, WEIGHT -	10 ⁰⁰⁰ kg
CAPACITY, VOLUME -	
MIN. CURVE -	41m
GEN. ARRGT. DRG N ^o -	

BRAKE -	VAC. PIPE & HAND SCREW
SUSPENSION -	SECONDARY COIL
COUPLINGS -	B R SCREW
BUFFERS -	SELF CONTAINED 406 DIA HEADS
WHEELS -	952 DIA
JOURNALS -	152 (6) ROLLER BEARINGS

ISSUE 1

TRAVELLING CRANE

YO 007 B

LOT NUMBER	
1497	

TOPS INFORMATION						
AARKND	OPERATING	OPERATING SPEED		BRAKE FORCE DATA		EXCESS LENGTH —
CARKND	PANEL NO.	45 mile/h UP TO		6t FORCE UP TO 83 tonne GLW		
Y O V J	9 3 4 0	mile/h ABOVE		83 tonne GLW		

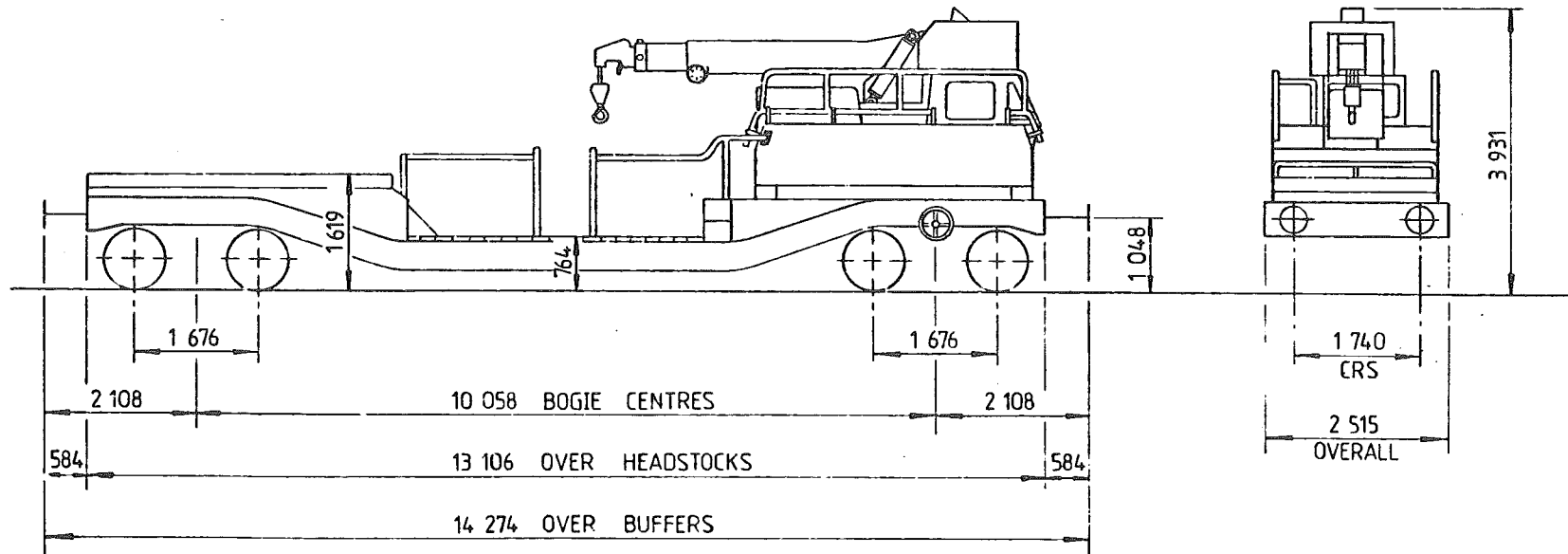

TARE -	83 ⁰⁰⁰ kg
CAPACITY, WEIGHT -	6 ⁵⁰⁰ kg
CAPACITY, VOLUME -	—
MIN. CURVE -	37m
GEN. ARRGT, DRG. N ^o . -	—

BRAKE -	VACUUM BLOCK & HAND SCREW
SUSPENSION -	SECONDARY COIL
COUPLINGS -	B.R. SCREW
BUFFERS -	SELF CONTAINED, 360 DIA HEADS
WHEELS -	833 DIA
JOURNALS -	280x140 PLAIN BEARINGS

ISSUE 1

EX DIAGRAM U258

TRAVELLING CRANE

YO 008 A

LOT NUMBER	
2614	

TOPS INFORMATION							
AARKND	OPERATING		OPERATING SPEED		BRAKE FORCE DATA		EXCESS LENGTH —
CARKND	PANEL NO.		35 mile/h UP TO		NO POWER BRAKE		
Y O R J	8	8	0	9			

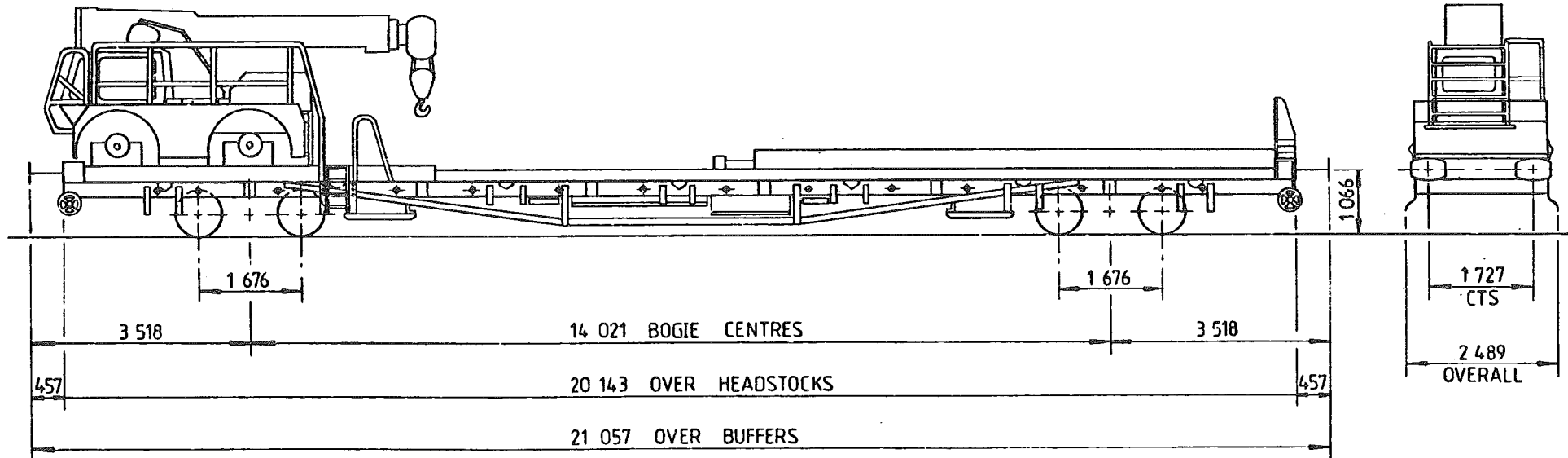

TARE -	73050kg
CAPACITY, WEIGHT -	6500kg
CAPACITY, VOLUME -	—
MIN. CURVE -	41m SINGLY, 76m CLOSE COUPLED
GEN. ARRGT. DRG. NO. -	SW-ES-245

BRAKE -	VACUUM & AIR PIPE, HAND SCREW
SUSPENSION -	SECONDARY COIL
COUPLINGS -	INSTANTER
BUFFERS -	SELF CONTAINED 559x356 OVAL HEADS
WHEELS -	762 DIA
JOURNALS -	280x140 PLAIN BEARINGS

ISSUE 1

BOGIE TRAVELLING CRANE

Y0009A

LOT NUMBER	

TOPS INFORMATION						
AARKND	OPERATING	OPERATING SPEED		BRAKE FORCE DATA		EXCESS LENGTH
CARKND	PANEL NO.	30mile/h UP TO		28t FORCE UP TO		
Y O B S	9 4 9 7	mile/h ABOVE		87tonne GLW		
				↑ FORCE ABOVE		

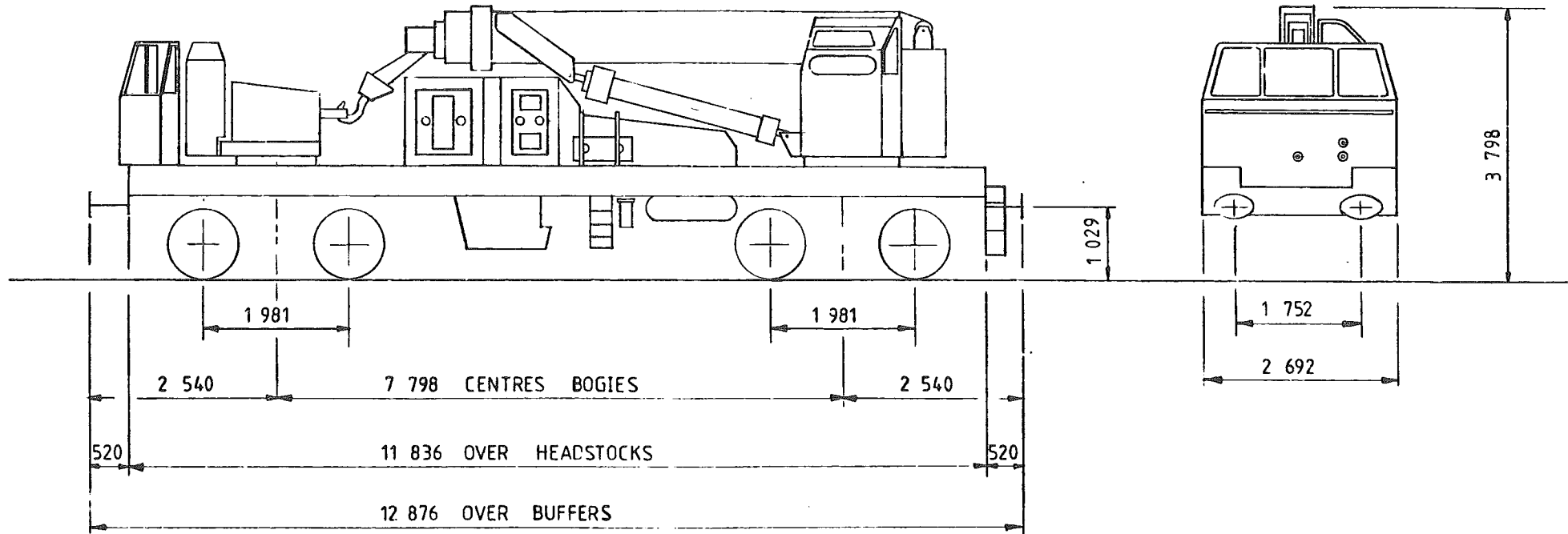

TARE -	87 ⁰⁰⁰ kg
CAPACITY, WEIGHT -	18 ⁰⁰⁰ kg
CAPACITY, VOLUME -	
MIN. CURVE -	
GEN. ARRGT. DRG. N ^o . -	

BRAKE -	AIR BRAKE & HAND SCREW
SUSPENSION -	SECONDARY COIL
COUPLINGS -	BR SCREW
BUFFERS -	HYDRAULIC (607x355) OVAL HEADS
WHEELS -	952 DIA
JOURNALS -	150 DIA

ISSUE 1

EX. DIAGRAM U/069

BOGIE TRAVELLING CRANE

YO 010A

LOT NUMBER	

TOPS INFORMATION						
AARKND	OPERATING	OPERATING SPEED		BRAKE FORCE DATA		EXCESS LENGTH
CARKND	PANEL NO.	45 mile/h UP TO	85tonne GLW	24t FORCE UP TO	85tonne GLW	
Y O B P	8 9 4 7	mile/h ABOVE		↑ FORCE ABOVE		

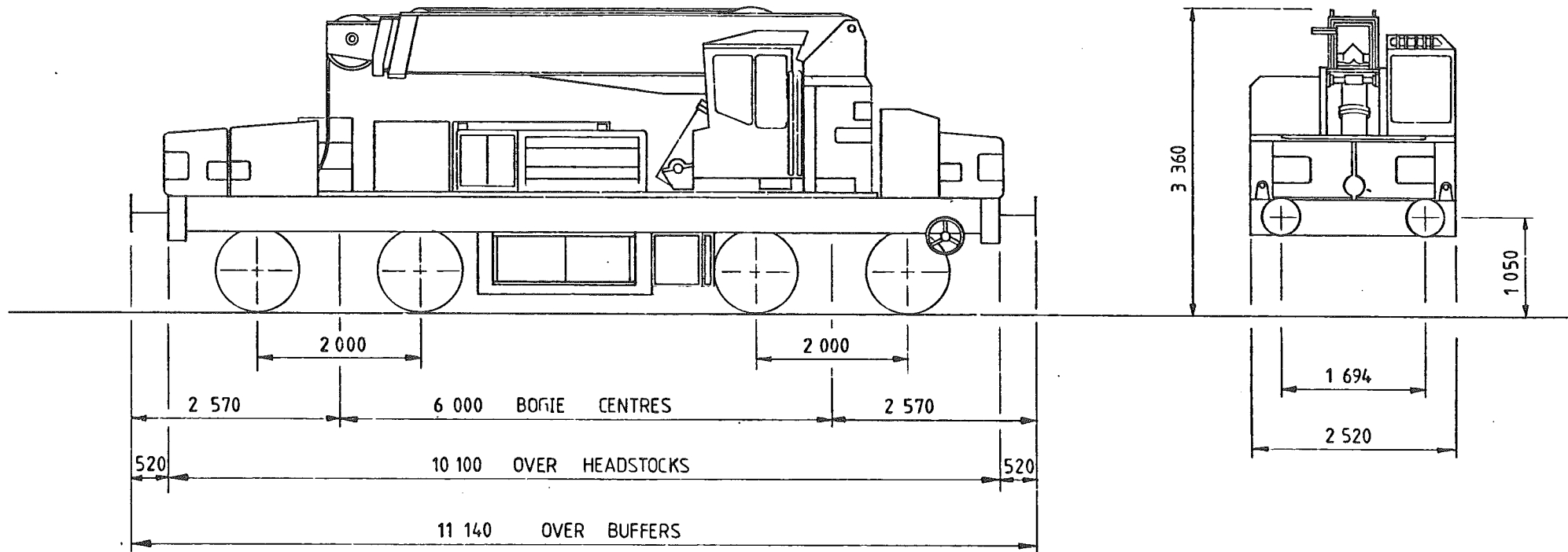

TARE -	85 ⁰⁰⁰ kg
CAPACITY, WEIGHT -	12 ⁰⁰⁰ kg
CAPACITY, VOLUME -	—
MIN. CURVE -	60m
GEN. ARRGT. DRG. N ^o . -	

BRAKE -	HAND SCREW & AIR BRAKE
SUSPENSION -	SECONDARY COIL
COUPLINGS -	BR SCREW
BUFFERS -	HYDRAULIC 457 DIA HEADS
WHEELS -	952 DIA
JOURNALS -	150 (6) DIA ROLLER BEARINGS

ISSUE 1

BOGIE TRAVELLING CRANE

YO 010B

LOT NUMBER	

TOPS INFORMATION								
AARKND	OPERATING		OPERATING SPEED			BRAKE FORCE DATA		EXCESS LENGTH
CARKND	PANEL NO.		40mile/h UP TO			24t FORCE UP TO		
Y O B P	8	2 5 1	mile/h ABOVE 85tonne GLW			t FORCE ABOVE 85tonne GLW		

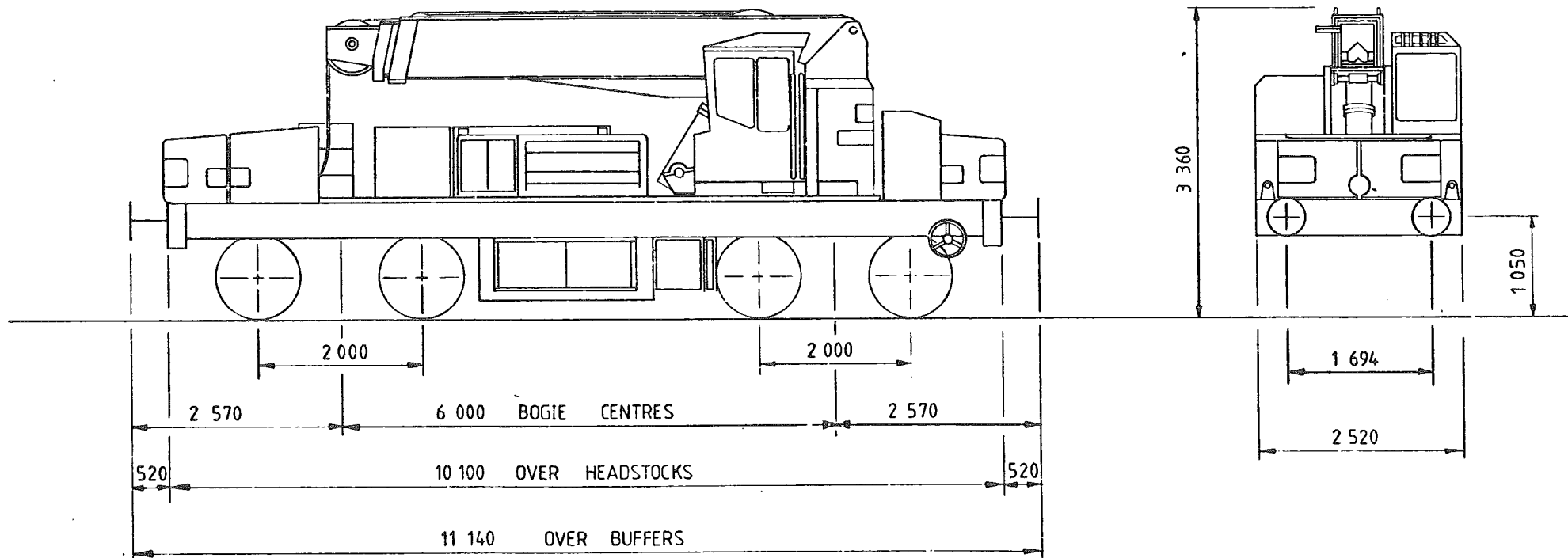

TARE -	85 ⁰⁰⁰ kg
CAPACITY, WEIGHT -	12 ⁰⁰⁰ kg
CAPACITY, VOLUME -	—
MIN. CURVE -	60m
GEN ARRGT ORG N ^o -	

BRAKE -	HAND SCREW & AIR BRAKE
SUSPENSION -	SECONDARY COIL
COUPLINGS -	3R SCREW
BUFFERS -	HYDRAULIC 457 DIA HEADS
WHEELS -	952 DIA
JOURNALS -	150 (6) DIA ROLLER BEARING

ISSUE 1

BOGIE TRAVELLING CRANE

YO 011A

LOT NUMBER	

TOPS INFORMATION										
AARKND		OPERATING			OPERATING SPEED			BRAKE FORCE DATA		EXCESS LENGTH
CARKND		PANEL NO.			35mile/h UP TO			24t FORCE UP TO		
Y	0	B	C	8	3	5	1	-mite/h ABOVE 86.5tonne GLW		
↑ FORCE ABOVE 86.5tonne GLW										

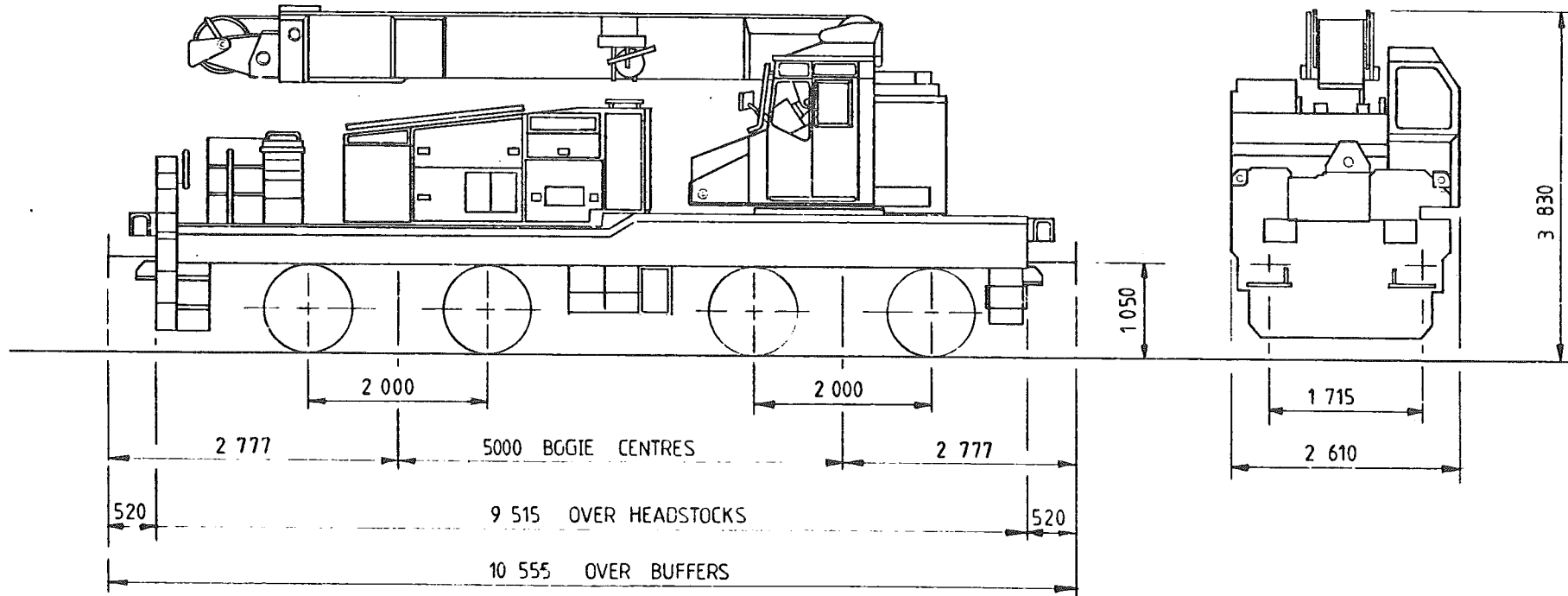

TARE -	86 ⁵⁰⁰ kg
CAPACITY, WEIGHT -	12 ⁰⁰⁰ kg
CAPACITY, VOLUME -	—
MIN. CURVE -	80m
GEN. ARRGT. DRG. N ^o . -	

BRAKE -	AIR BLOCK, VAC PIPE, HAND SCREW
SUSPENSION -	SECONDARY COIL
COUPLINGS -	BR SCREW
BUFFERS -	PNEUMATIC 457 DIA HEADS
WHEELS -	952 DIA
JOURNALS -	150 DIA ROLLER BEARINGS

ISSUE 1

EX. BR DIAGRAM

STORES AND MATERIALS - DEN PARTS

YR 001A

LOT NUMBER	
3165	
3259	
3299	

TOPS INFORMATION						
AARKND	OPERATING		OPERATING SPEED		BRAKE FORCE DATA	EXCESS LENGTH
CARKND	PANEL NO.		50 mile/h UP TO		NO POWER BRAKE	
Y R P C	0	5	2	9		

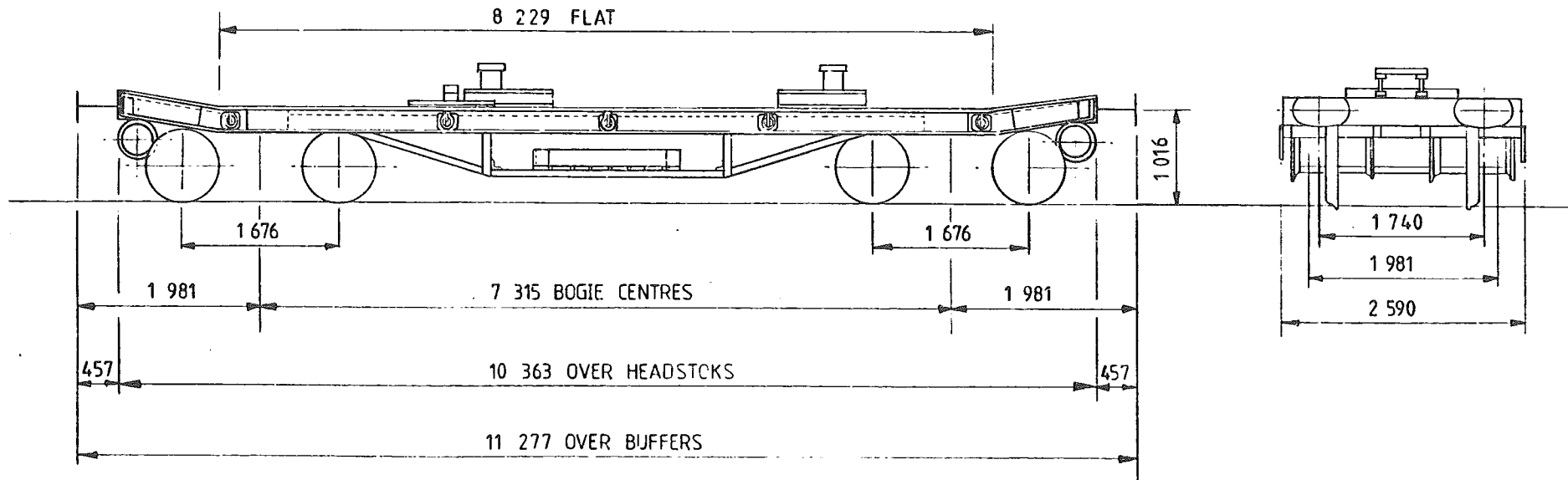

TARE -	16 ⁰⁰⁰ kg
CAPACITY, WEIGHT -	38 ⁵⁰⁰ kg
CAPACITY, VOLUME -	—
MIN. CURVE -	22m
GEN. ARRGT. DRG N ^o -	DN 28013

BRAKE -	HAND SCREW & VACUUM THRO PIPE
SUSPENSION -	SECONDARY COIL
COUPLINGS -	INSTANTER
BUFFERS -	SELF CONTAINED 610x356 OVAL HEADS
WHEELS -	762 DIA
JOURNALS -	124 DIA ROLLER BEARINGS

ISSUE 1

EX. BR. DIAGRAM

X/440

WELTROL

YR 002A

LOT NUMBER	
3102	
3192	

TOPS INFORMATION										
AARKND		OPERATING		OPERATING SPEED				BRAKE FORCE DATA		EXCESS LENGTH
CARKND		PANEL NO.		45 mile/h UP TO		34 tonne GLW		NO POWER BRAKE		7
Y	R	P	C	0	5	5	6	40 mile/h ABOVE		

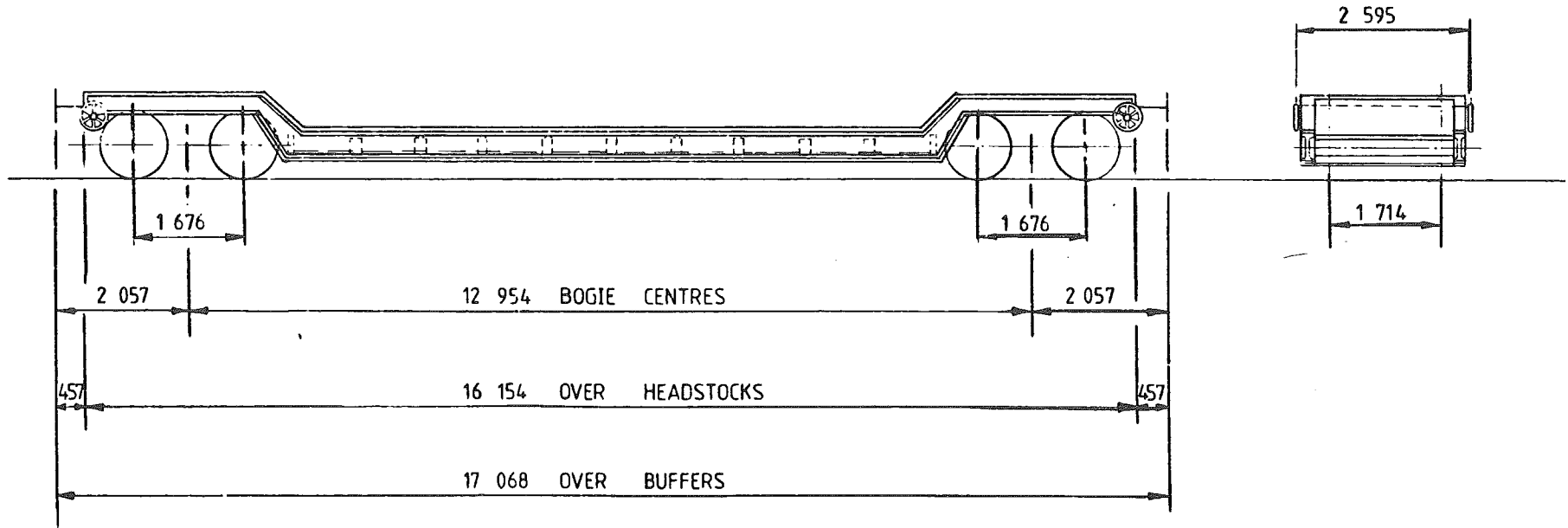

TARE -	18 ⁴⁵⁰ kg
CAPACITY, WEIGHT -	25 ⁵⁰⁰ kg
CAPACITY, VOLUME -	—
MIN. CURVE -	31m
GEN ARRGT. DRG N ^o -	SW/SW/192

BRAKE -	HAND SCREW & VACUUM 'THRO' PIPE
SUSPENSION -	SECONDARY COIL
COUPLINGS -	INSTANTER
BUFFERS -	SELF CONTAINED (610x356) OVAL HEADS
WHEELS -	952 DIA
JOURNALS -	111 DIA ROLLER BEARINGS

ISSUE 1

EX BR DIAGRAM (SP) X741

CRANE RUNNER

YS 011 D

LOT NUMBER	
1189	

TOPS INFORMATION									
AARKND		OPERATING		OPERATING SPEED		BRAKE FORCE DATA		EXCESS LENGTH —	
CARKND		PANEL NO.		45 mile/h UP TO		6t FORCE UP TO			
Y	S	B	A	8	6	8	3		20 tonne GLW
								mile/h ABOVE	↑ FORCE ABOVE

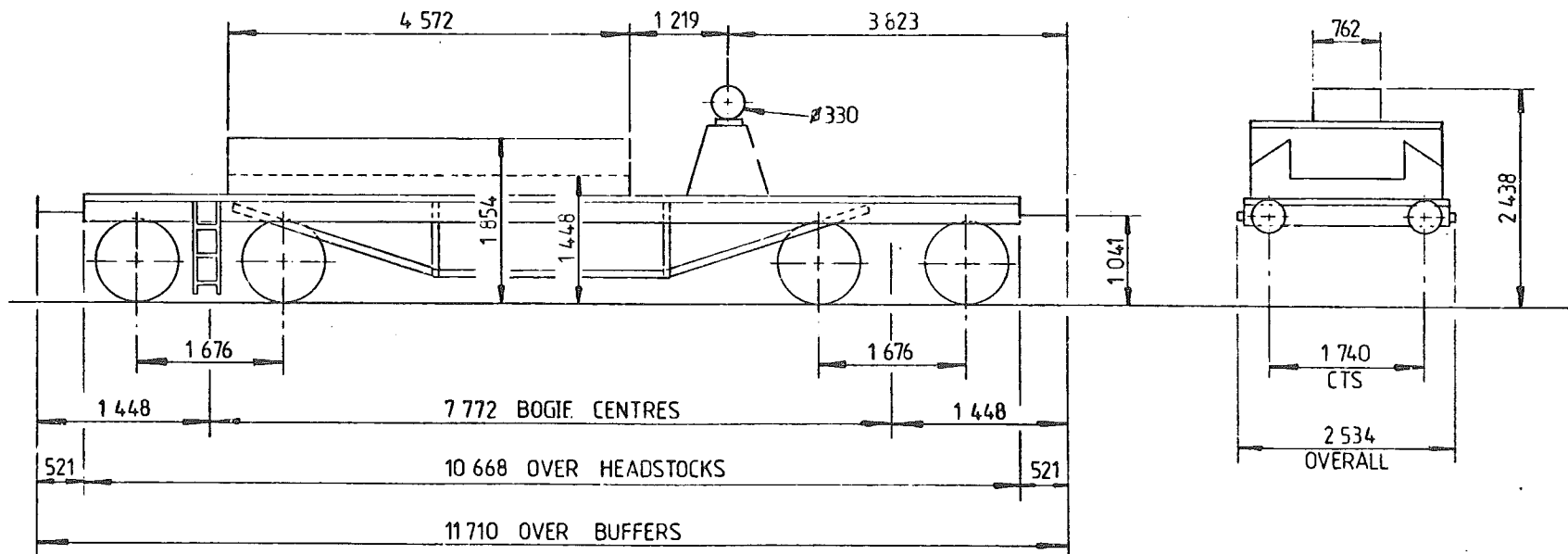

TARE -	15 ⁰⁰⁰ kg
CAPACITY, WEIGHT -	20 ⁰⁰⁰ kg
CAPACITY, VOLUME -	—
MIN. CURVE -	
GEN. ARRGT. DRG N ^o . -	—

BRAKE -	AIR BRAKE, THRO VAC PIPE, HAND LEVER
SUSPENSION -	COIL SPRING
COUPLINGS -	INSTANTER
BUFFERS -	SELF CONTAINED, 406 DIA HEADS
WHEELS -	953 DIA
JOURNALS -	114(4½") DIA PLAIN BEARINGS

ISSUE 1

EX.GWR DIAGRAM J25

TROLLEY FLAT

YV 001B

LOT NUMBER	
3416	

TOPS INFORMATION										
AARKND		OPERATING				OPERATING SPEED		BRAKE FORCE DATA		EXCESS LENGTH
CARKND		PANEL NO.				50 mile/h UP TO		9 t FORCE UP TO		1
Y	V	W	F	7	1	6	6	71 tonne GLW		
						mile/h ABOVE		t FORCE ABOVE		

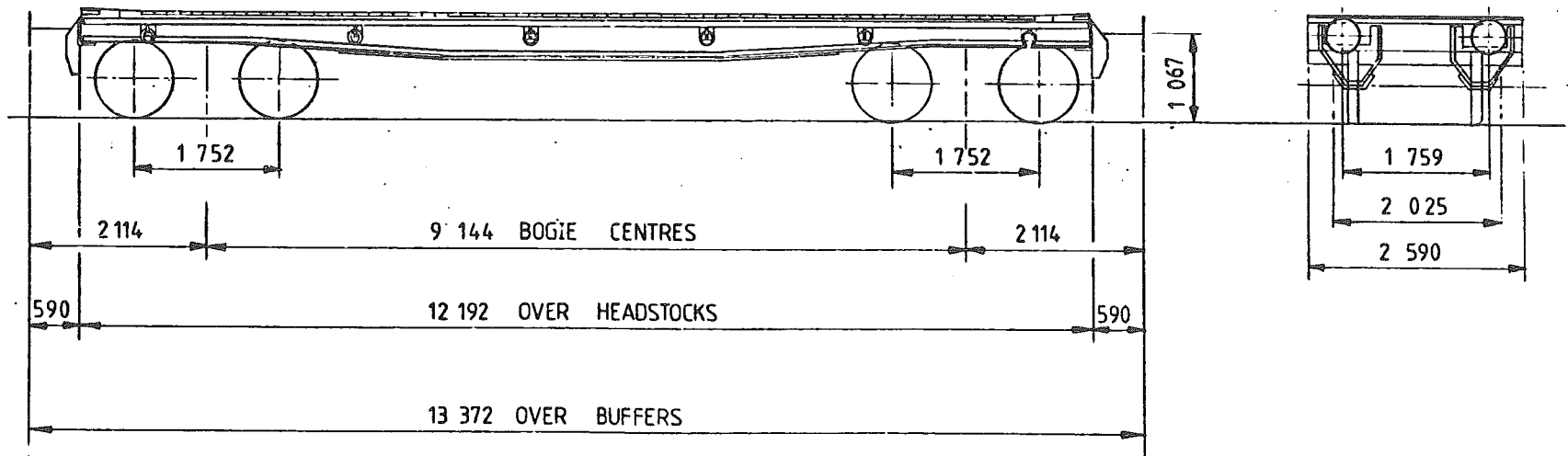

TARE -	19550 kg
CAPACITY, WEIGHT -	51000 kg
CAPACITY, VOLUME -	
MIN. CURVE -	37m
GEN. ARRGT. DRG. N ^o -	142947

BRAKE -	VACUUM BLOCK, HAND SCREW
SUSPENSION -	SECONDARY COIL
COUPLINGS -	BR SCREW
BUFFERS -	SELF CONTAINED 381 DIA HEAD
WHEELS -	914 DIA
JOURNALS -	280x140 PLAIN BEARINGS

ISSUE 1

CRIPPLE CARRIER

YV 001C

LOT NUMBER	
3416	

TOPS INFORMATION										
AARKND		OPERATING		OPERATING SPEED			BRAKE FORCE DATA		EXCESS LENGTH	
CARKND		PANEL NO.		50 mile/h UP TO			9 f FORCE UP TO		1	
Y	V	V	F	0	5	0	9	71 tonne GLW		
				mile/h ABOVE			+ FORCE ABOVE		71 GLW	

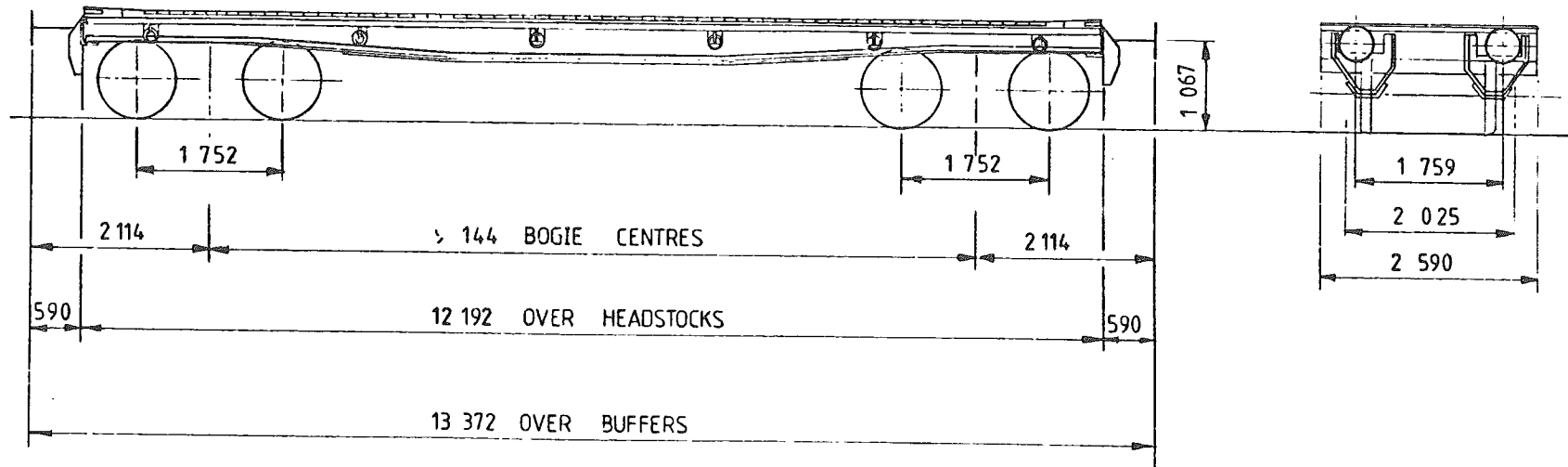

TARE -	19 ⁵⁵⁰ kg
CAPACITY, WEIGHT -	51 ⁰⁰⁰ kg
CAPACITY, VOLUME -	
MIN. CURVE -	37m
GEN. ARRGT. DRG. N ^o -	142947

BRAKE -	VACUUM BLOCK, HAND SCREW
SUSPENSION -	SECONDARY COIL
COUPLINGS -	BR SCREW
BUFFERS -	SELF CONTAINED 381 DIA HEAD
WHEELS -	914 DIA
JOURNALS -	280x140 FLAIN BEARINGS

ISSUE 1

EX. BR. DIAGRAM X1073

FLAT WAGON

YV 002A

LOT NUMBER	
3044	

TOPS INFORMATION					
AARKND	OPERATING	OPERATING SPEED		BRAKE FORCE DATA	EXCESS LENGTH 1
CARKND	PANEL NO.	50 mile/h UP TO mile/h ABOVE		NO POWER BRAKE	
Y V O C	0 5 1 0	62 tonne GLW			

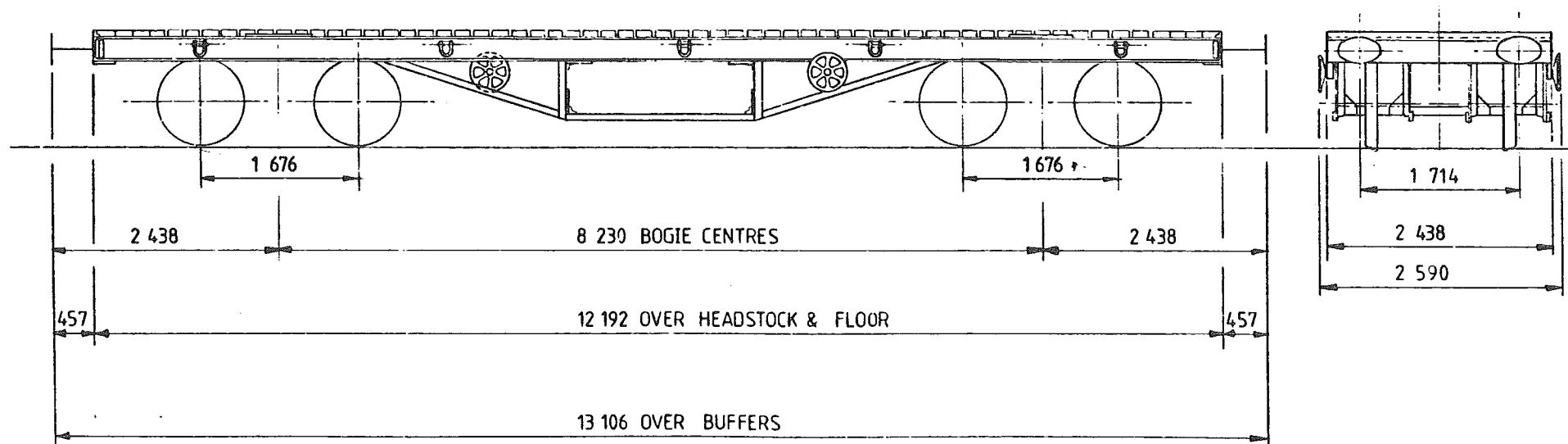

TARE -	16 ⁰⁵⁰ kg
CAPACITY, WEIGHT -	46 ⁰⁰⁰ kg
CAPACITY, VOLUME -	—
MIN. CURVE -	22m
GEN. ARRGT. DRG. N ^o . -	DN 20560

BRAKE -	HAND SCREW
SUSPENSION -	SECONDARY COIL
COUPLINGS -	INSTANTER
BUFFERS -	SPINDLE 457x305 OVAL HEADS
WHEELS -	952 DIA
JOURNALS -	254 x 127 PLAIN BEARINGS

ISSUE 1

EX. BR. DIAGRAM X1074

FLATROL

YV 004 A

LOT NUMBER	
2219	
	-

TOPS INFORMATION					
AARKND	OPERATING	OPERATING SPEED		BRAKE FORCE DATA	EXCESS LENGTH
CARKND	PANEL NO.	45 mile/h UP TO	41 tonne GLW	NO POWER BRAKE	—
Y V O C	7 1 2 1	40 mile/h ABOVE			

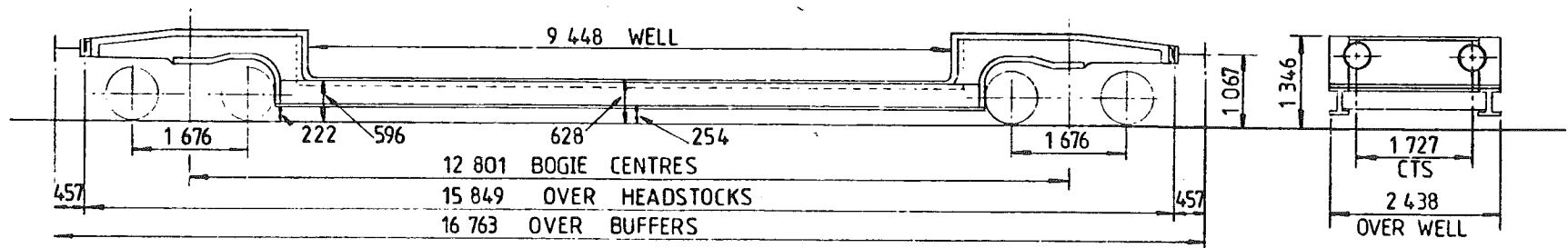

TARE -	22 ⁵⁰⁰ kg
CAPACITY, WEIGHT -	25 ⁵⁰⁰ kg
CAPACITY, VOLUME -	—
MIN. CURVE -	22m
GEN. ARRGT. DRG. N ^o .	-13520N

BRAKE -	HAND LEVER
SUSPENSION -	SECONDARY COIL
COUPLINGS -	BR. SCREW
BUFFERS -	SELF CONTAINED, 457 DIA HEADS
WHEELS -	812 DIA
JOURNALS -	228x114(9"x4½") PLAIN BEARINGS

6 SHACKLES ARE FITTED TO EACH SOLEBAR IN THE WELL.
4 LASHING RINGS ARE FITTED TO SOLEBAR OVER BOGIE.
2 LASHING RINGS ARE FITTED TO HEADSTOCK.

ISSUE 1

EX. BR. SPECIAL DIAGRAM 2/517.

FLATROL

YV 006A

LOT NUMBER	
3303	

TOPS INFORMATION							
AARKND		OPERATING		OPERATING SPEED		BRAKE FORCE DATA	EXCESS LENGTH
CARKND		PANEL NO.		45 mile/h UP TO		NO POWER BRAKE	800
Y	V	R	C	7	1	2	3
				40 mile/h ABOVE			48 tonne GLW

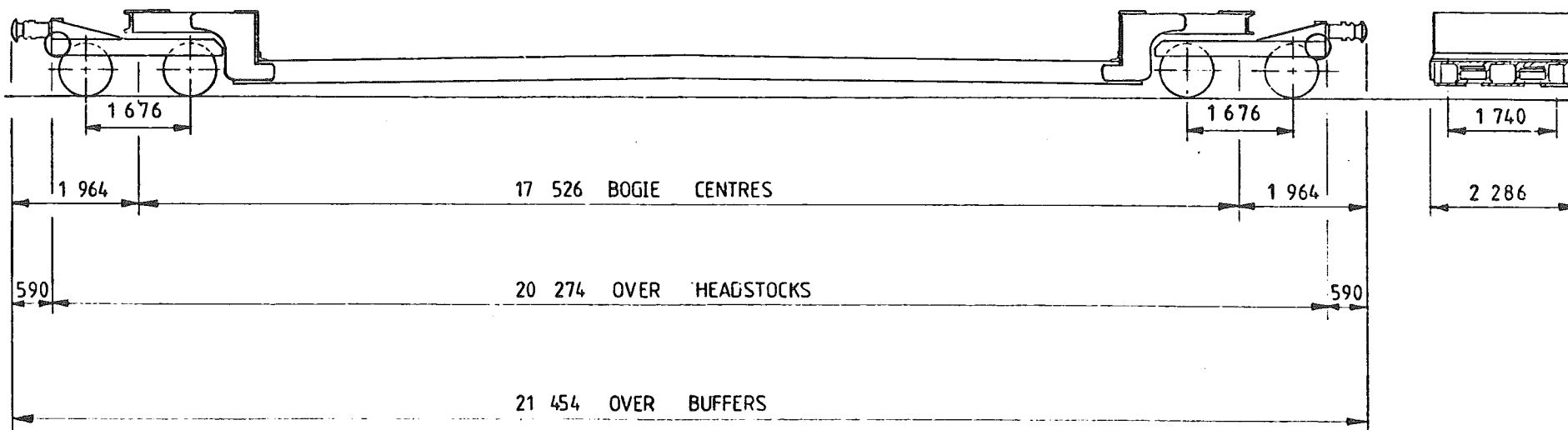

TARE -	29 950 kg
CAPACITY, WEIGHT -	25 500 kg
CAPACITY, VOLUME -	
MIN. CURVE -	31m
GEN. ARRGT. DRG. N ^o -	DE / 21244

BRAKE -	AIR PIPED, VACUUM PIPED, HAND SCREW
SUSPENSION -	SECONDARY COIL
COUPLINGS -	B.R. SCREW
BUFFERS -	SELF CONTAINED 400 DIA HEAD
WHEELS -	876 DIA
JOURNALS -	124 DIA ROLLER BEARINGS

ISSUE 1

EX. BR. DIAGRAM(S) X/526

CRIPPLE CARRIER

YV 009B

LOT NUMBER	

TOPS INFORMATION											
AARKND		OPERATING			OPERATING SPEED			BRAKE FORCE DATA		EXCESS LENGTH	
CARKND		PANEL NO.			45mile/h UP TO			NO POWER BRAKE			
Y	V	P	F	8	7	1	7	40mile/h ABOVE			50 tonne GLW

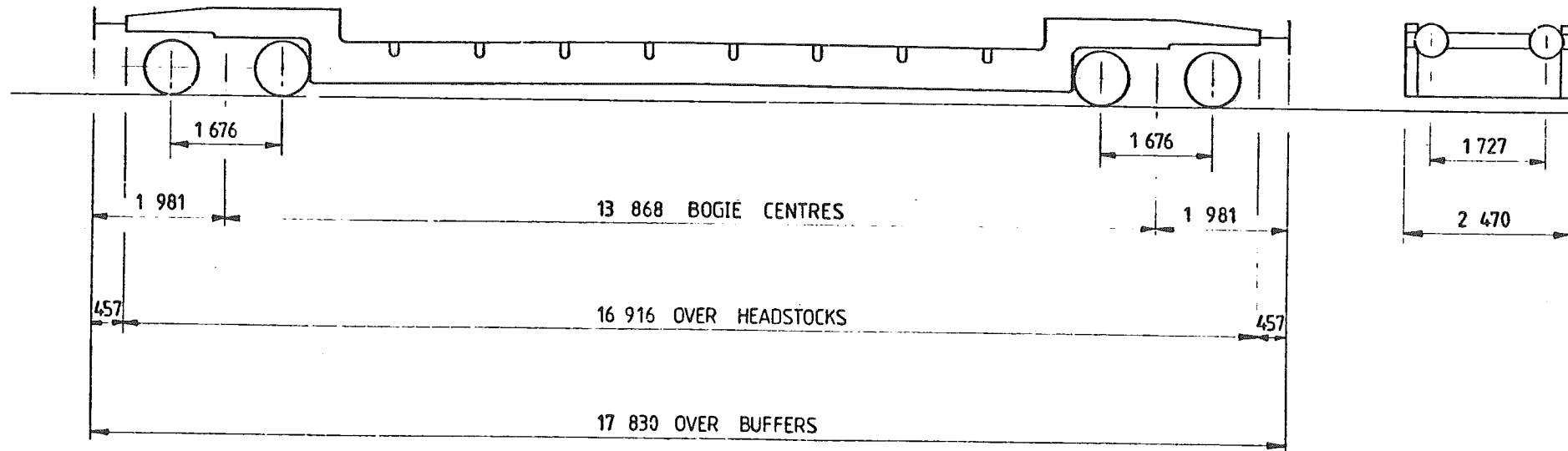

TARE -	24 ⁵⁰⁰ Kg
CAPACITY, WEIGHT -	25 ⁵⁰⁰ kg
CAPACITY, VOLUME -	
MIN. CURVE -	
GEN. ARRGT. DRG. N ^o . -	

BRAKE -	HAND LEVER & VACUUM 'THRO' PIPE
SUSPENSION -	SECONDARY COIL
COUPLINGS -	INSTANTER
BUFFERS -	SPINDLE 457x457 DIA HEADS
WHEELS -	812 DIA
JOURNALS -	228 x 114 (9x4½) PLAIN BEARINGS

ISSUE1

EX.LNERDIAGRAM 151

CRIPPLE CARRIER

YV 012 A

LOT NUMBER	
2029	

TOPS INFORMATION					
AARKND	OPERATING	OPERATING SPEED		BRAKE FORCE DATA	EXCESS LENGTH 2
CARKND	PANEL NO.	45 mile/h UP TO		NO POWER BRAKE	
Y V O F	0 5 5 0	40 mile/h ABOVE			

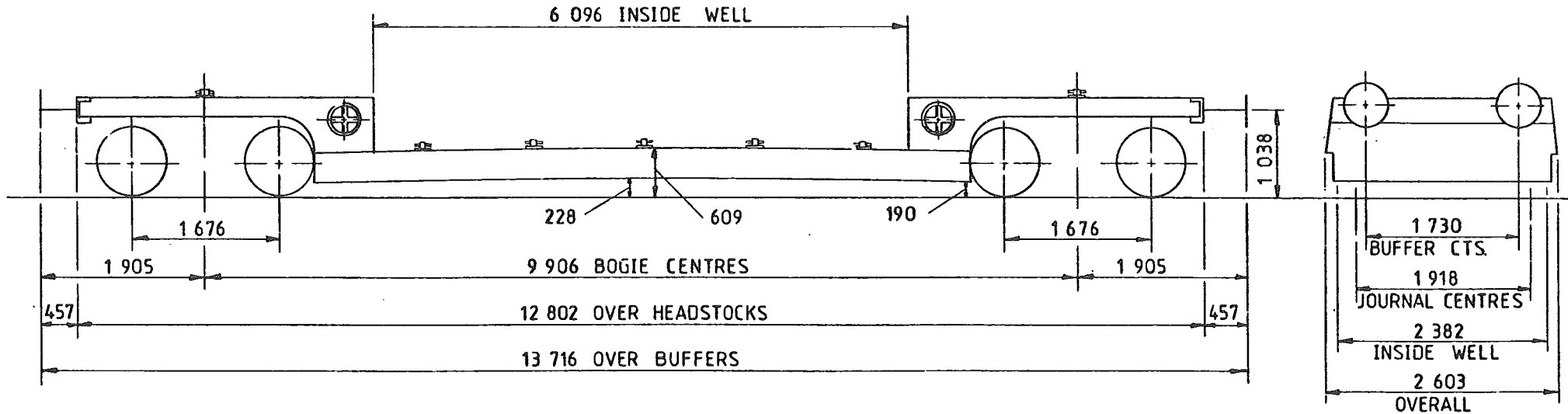

TARE -	18 200 kg
CAPACITY, WEIGHT -	20 500 kg
CAPACITY, VOLUME -	
MIN. CURVE -	21m
GEN. ARRGT. DRG. N ^o -	D11/404

BRAKE -	HAND SCREW
SUSPENSION -	SECONDARY COIL
COUPLINGS -	INSTANTER
BUFFERS -	SELF CONTAINED, 457 DIA. HEADS
WHEELS -	826 DIA.
JOURNALS -	381 x 108 (15" x 4") PLAIN BEARINGS

5 BINDING RINGS FITTED TO EACH SOLEBAR IN WELL.
2 BINDING RINGS FITTED TO EACH SOLEBAR OVER BOGIE.

ISSUE 1

EX. BR. DIAGRAM 2/730

WELTROL

YV 016A

LOT NUMBER	
3102	
3192	

TOPS INFORMATION								
AARKND		OPERATING		OPERATING SPEED		BRAKE FORCE DATA		EXCESS LENGTH
CARKND		PANEL NO.		45 mile/h UP TO		NO POWER BRAKE		7
Y	V	P	F	0	5	5	6	
				40 mile/h ABOVE				
				34 tonne GLW				

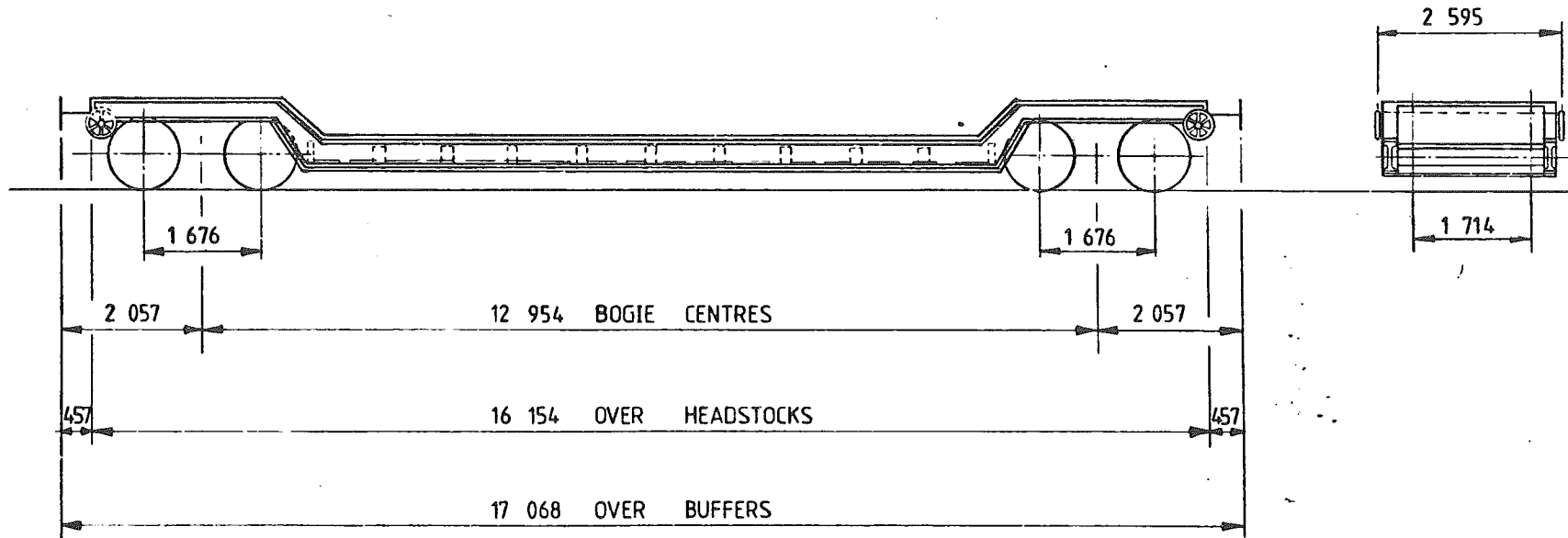

TARE -	18 459 kg
CAPACITY, WEIGHT -	25 500 kg
CAPACITY, VOLUME -	—
MIN. CURVE -	31m
GEN. ARRGT. DRG. NO. -	SW/SW/192

BRAKE -	HAND SCREW & VACUUM THRO' PIPE
SUSPENSION -	SECONDARY COIL
COUPLINGS -	INSTANTER
BUFFERS -	SELF CONTAINED (610x356) OVAL HEADS
WHEELS -	952 DIA
JOURNALS -	111 DIA ROLLER BEARINGS

ISSUE 1

EX. BR DIAGRAM(SPI) X741

BOGIE BOLSTER WAGON

YV021A

LOT NUMBER	

TOPS INFORMATION						
AARKND	OPERATING		OPERATING SPEED		BRAKE FORCE DATA	EXCESS LENGTH
CARKND	PANEL NO.		45 mile/h UP TO		NO POWER BRAKE	
Y V P G	8 7 0 6	mile/h ABOVE		46 tonne GLW		

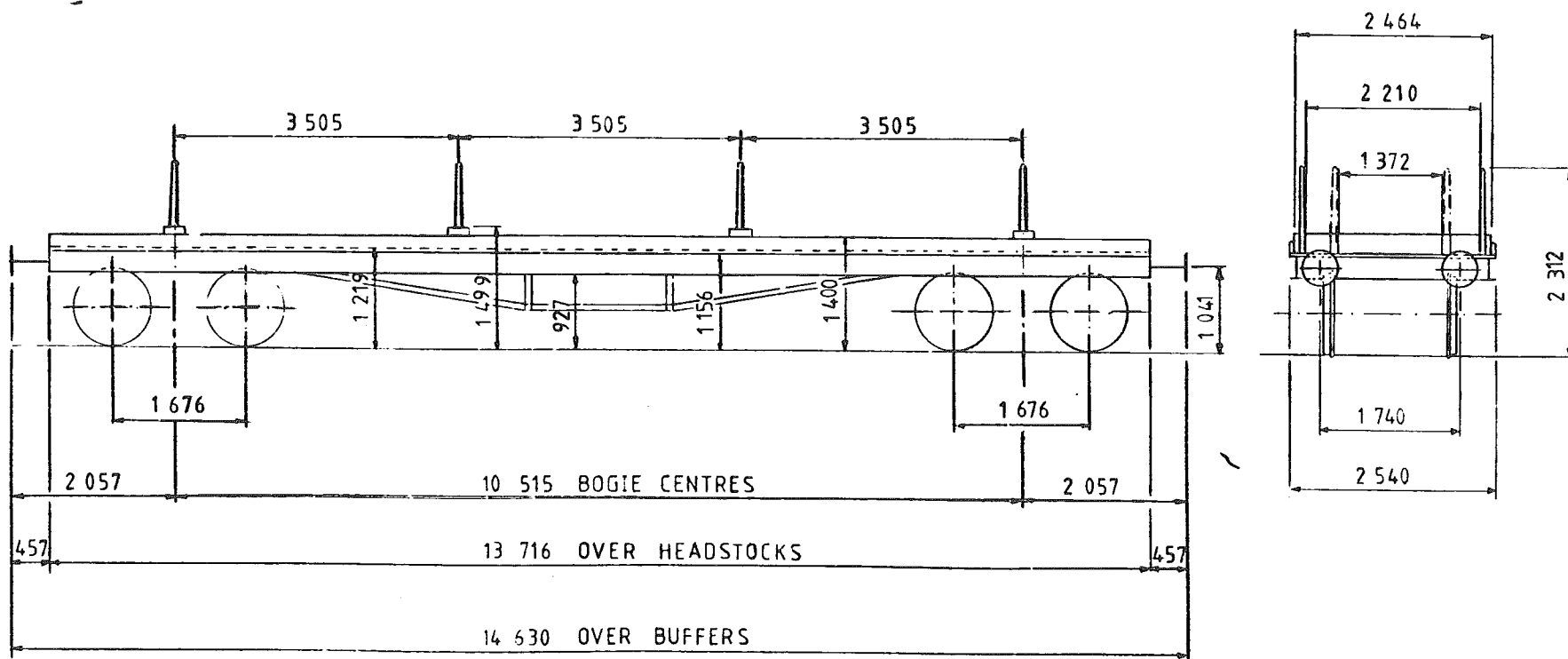

TARE -	14 ⁸⁰⁰ Kg
CAPACITY, WEIGHT -	30 ⁵⁰⁰ Kg
CAPACITY, VOLUME -	-----
MIN. CURVE -	21m
GEN. ARRGT. DRG. N ^o -	6468

BRAKE -	HAND LEVER & VACUUM THRO' PIPE
SUSPENSION -	SECONDARY COIL
COUPLINGS -	BR SCREW
BUFFERS -	SELF CONTAINED 457 DIA HEADS
WHEELS -	952 DIA
JOURNALS -	228 x 114 (9" x 4 1/2") PLAIN BEARINGS

ISSUE 1

EX LMS SPECIAL DIAGRAM 11

WELTROL

YV046A

LOT NUMBER	
3102	
3192	

TOPS INFORMATION						
AARKND	OPERATING		OPERATING SPEED		BRAKE FORCE DATA	EXCESS LENGTH 7
CARKND	PANEL NO.		45 mile/h UP TO		NO POWER BRAKE	
Y V P R	0	5	5	6		
				34 tonne GLW		

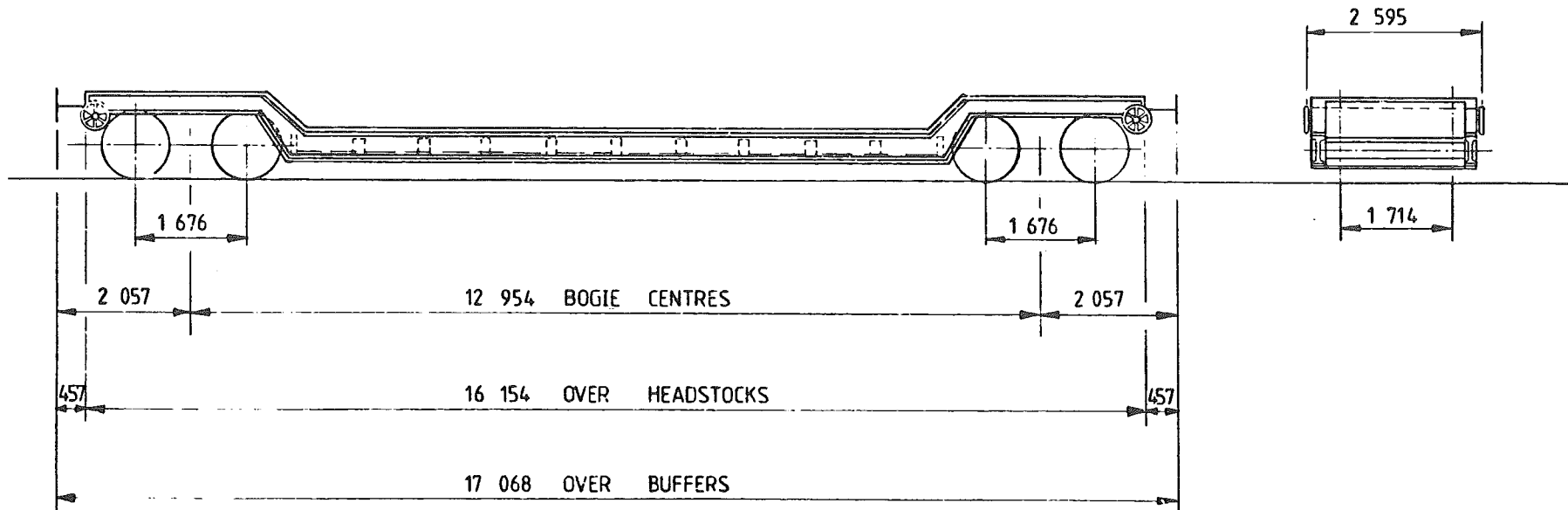

TARE -	19 000 kg
CAPACITY, WEIGHT -	25 500 kg
CAPACITY, VOLUME -	—
MIN. CURVE -	31m
GEN ARRGT. DRG. N ^o -	SW / SW / 192

BRAKE -	HAND SCREW & VACUUM 'THRO' PIPE
SUSPENSION -	SECONDARY COIL
COUPLINGS -	INSTANTER
BUFFERS -	SELF CONTAINED (610x356) OVAL HEADS
WHEELS -	952 DIA
JOURNALS -	111 DIA ROLLER BEARINGS

ISSUE 1

EX BR DIAGRAM (SP) X741

TUNNEL INSPECTION VEHICLE

YX035B

LOT NUMBER	
4024	

TOPS INFORMATION					
AARKND	OPERATING PANEL NO.	OPERATING SPEED		BRAKE FORCE DATA	EXCESS LENGTH
		55 mile/h UP TO		9t FORCE UP TO	
		mile/h ABOVE		FORCE ABOVE	tonne GLW
Y X V	0 1 5 6				

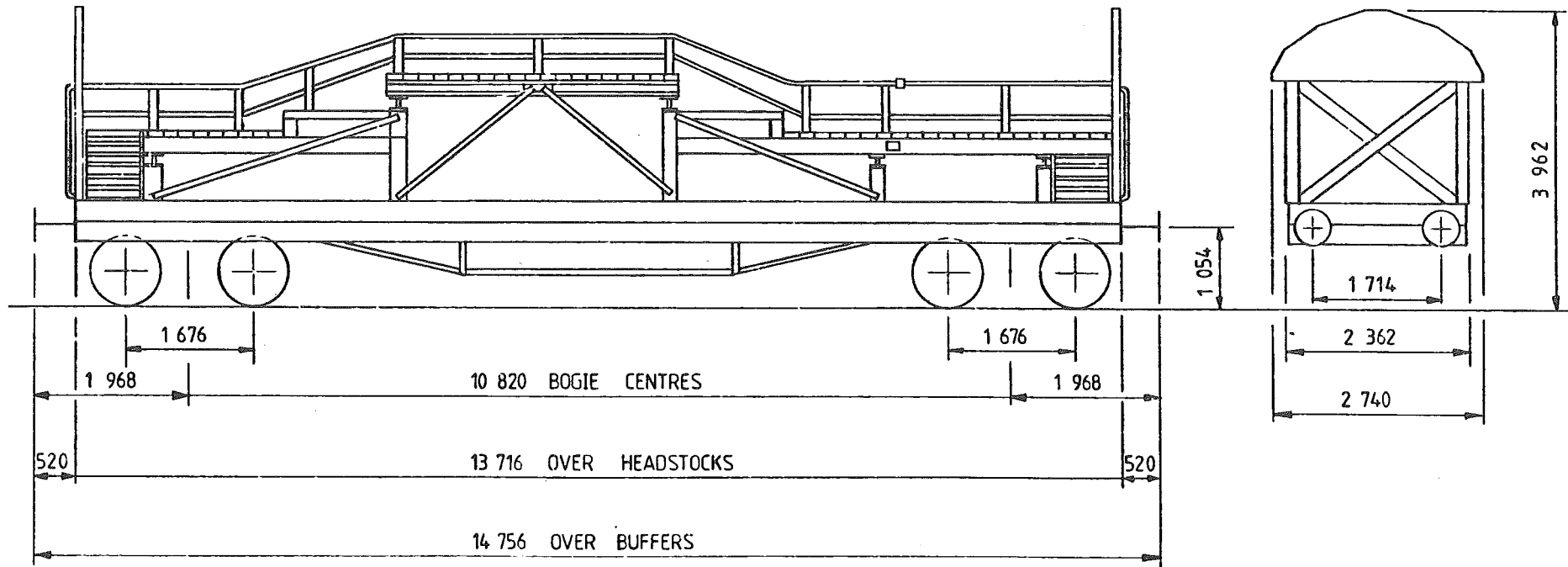

TARE -	15 ⁰⁰ kg
CAPACITY, WEIGHT -	30 ⁵⁰⁰ kg
CAPACITY, VOLUME -	
MIN. CURVE -	31m
GEN ARRGT. DRG NO. -	GL-F-AI-113

BRAKE -	HAND LEVER & VACUUM BLOCK
SUSPENSION -	SECONDARY COIL
COUPLINGS -	INSTANTER
BUFFERS -	SELF CONTAINED (406) DIA HEADS
WHEELS -	952 DIA
JOURNALS -	111 DIA ROLLER BEARINGS

ISSUE 1

EX. BR DIAGRAM 477

BOGIE BOLSTER WAGON

YY011B

LOT NUMBER	
2308	

TOPS INFORMATION										
AARKND		OPERATING			OPERATING SPEED			BRAKE FORCE DATA		EXCESS LENGTH 9
CARKND		PANEL NO.			50 mile/h UP TO			NO POWER BRAKE		
Y	Y	P	G	7	G	2	1	- mile/h ABOVE 46 tonne GLW		

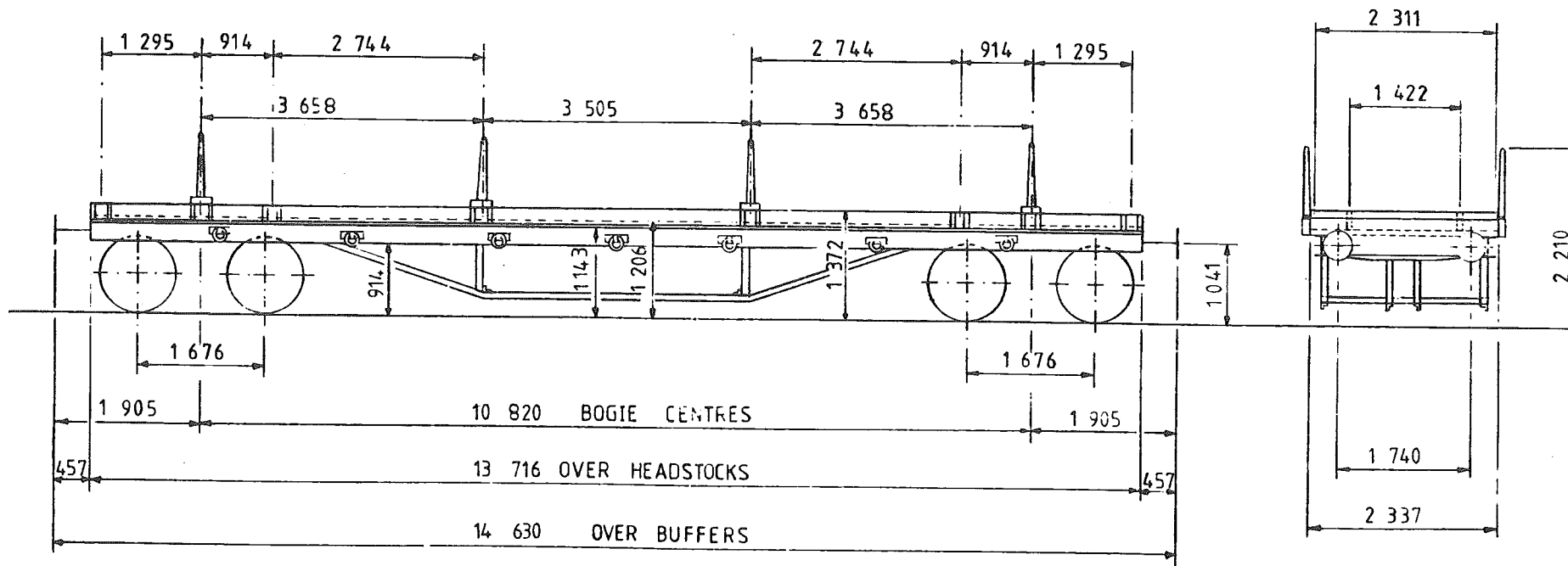

22

TARE -	13 ⁵⁰⁰ kg
CAPACITY, WEIGHT -	30 ⁵⁰⁰ kg
CAPACITY, VOLUME -	—
MIN. CURVE -	30 m
GEN ARRGT. DRG. NO. -	49281 ^A

BRAKE -	HAND LEVER & VACUUM THRO' PIPE
SUSPENSION -	SECONDARY COIL
COUPLINGS -	INSTANTER
BUFFERS -	SELF CONTAINED 406 x 457 DIA HEADS
WHEELS -	952 DIA
JOURNALS -	114 x 203 (4 1/2 x 8) PLAIN BEARINGS

ISSUE 1

BOGIE BOLSTER WAGON

YY012A

LOT NUMBER	
2542	
2583	

TOPS INFORMATION										
AARKND		OPERATING		OPERATING SPEED			BRAKE FORCE DATA		EXCESS LENGTH	
CARKND		PANEL NO.		50mile/h UP TO			NO POWER BRAKE		3	
Y Y 0 G		0 0 2 6		-mile/h ABOVE 46tonne GLW						

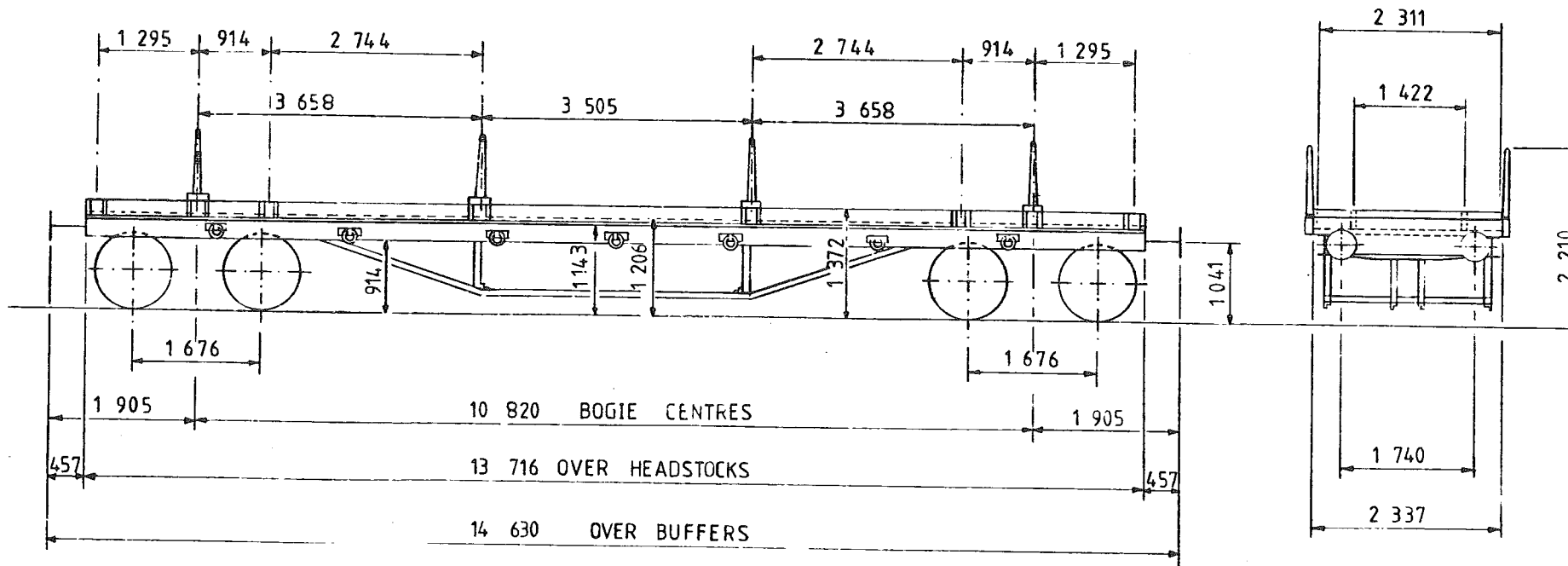

TARE -	15 500 Kg
CAPACITY, WEIGHT -	30 500 Kg
CAPACITY, VOLUME -	—
MIN. CURVE -	30 m
GEN. ARRGT. DRG. NO. -	49281 ^A

BRAKE -	HAND LEVER
SUSPENSION -	SECONDARY COIL
COUPLINGS -	INSTANTER
BUFFERS -	SELF CONTAINED 406x45/DIA HEADS
WHEELS -	952 DIA
JOURNALS -	114 x 203 (4 1/2 x 8) PLAIN BEARINGS

ISSUE 1

EX. BR. DIAGRAM B 473

BOGIE BOLSTER WAGON

YY014A

LOT NUMBER	

TOPS INFORMATION						
AARKND	OPERATING		OPERATING SPEED		BRAKE FORCE DATA	EXCESS LENGTH
CARKND	PANEL NO.		45mile/h UP TO			
Y Y V G	8	7	4	6	61 tonne GLW	14 t FORCE UP TO
					mile/h ABOVE	↑ FORCE ABOVE 61 tonne GLW

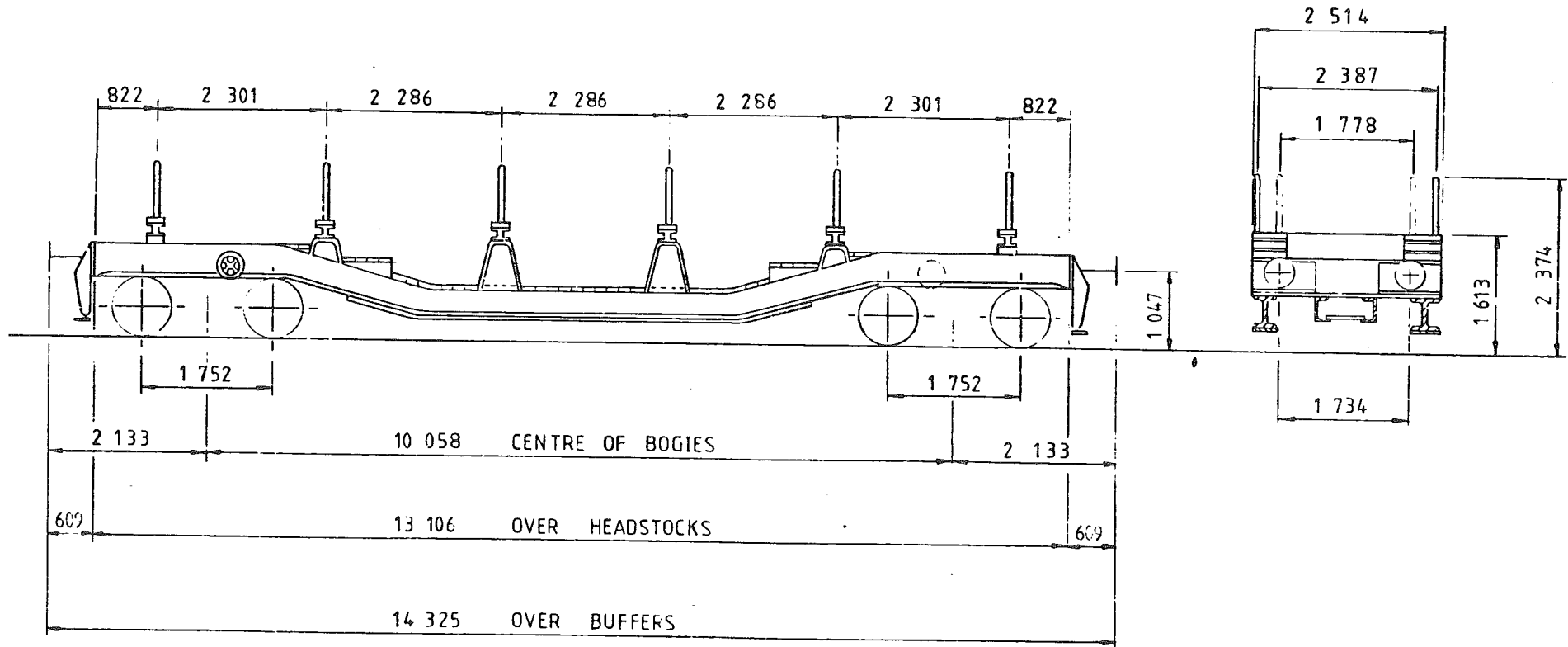

TARE -	30 ⁴⁵⁰ kg
CAPACITY, WEIGHT -	30 ⁴⁰⁰ kg
CAPACITY, VOLUME -	
MIN. CURVE -	36.5m
GEN ARRGT. DRG N ^o -	124-56 ^A

BRAKE -	VACUUM BRAKE & HAND SCREW
SUSPENSION -	SECONDARY COIL
COUPLINGS -	INTERNATIONAL SCREW
BUFFERS -	406x620 DIA HEADS
WHEELS -	838 DIA
JOURNALS -	280x140 (11x5 1/2) PLAIN BEARINGS

ISSUE 1

EXLNER DIAGRAM E 212

BOGIE RAIL WAGON

YY 017 A

LOT NUMBER	
1273	

TOPS INFORMATION						
AARKND	OPERATING		OPERATING SPEED		BRAKE FORCE DATA	
CARKND	PANEL NO.		50 mile/h UP TO		NO POWER BRAKE	
Y Y 0 G	0 0 2 6		mile/h ABOVE 45 tonne GLW			
						EXCESS LENGTH
						3

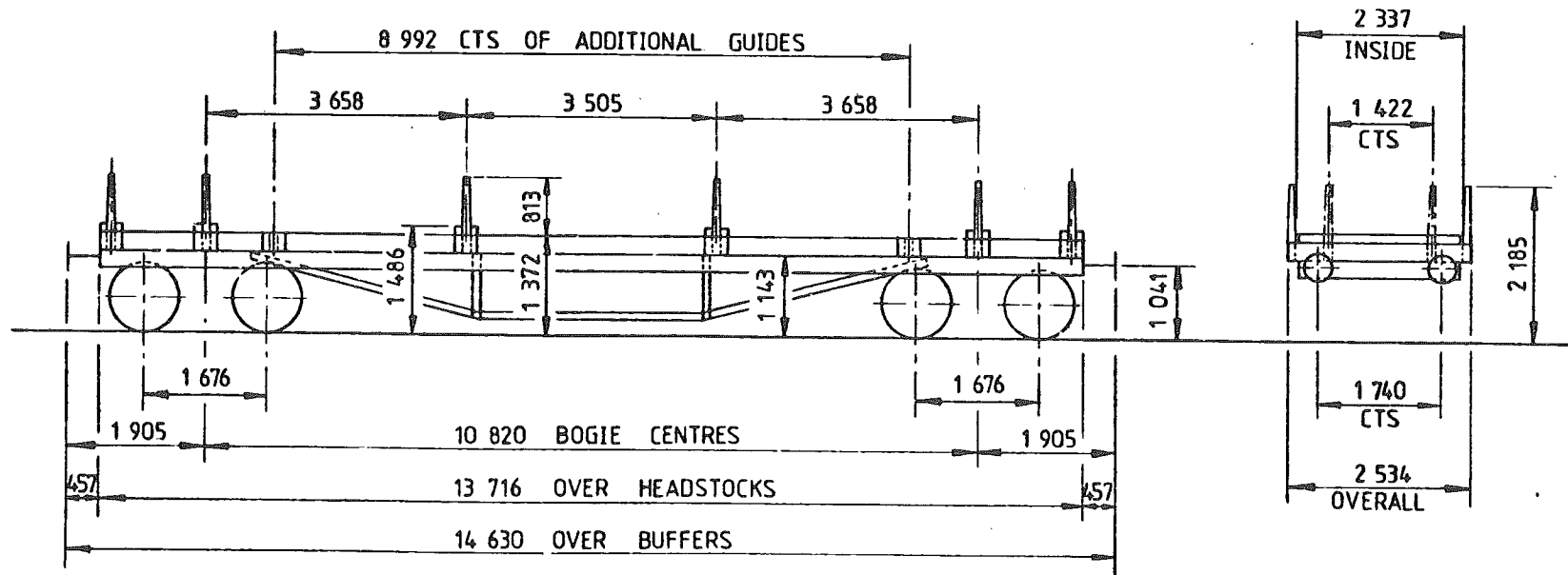

TARE -	15550kg
CAPACITY, WEIGHT -	30500kg
CAPACITY, VOLUME -	—
MIN. CURVE -	—
GEN. ARRGT. DRG. NO. -	—

BRAKE -	HAND LEVER
SUSPENSION -	SECONDARY COIL
COUPLINGS -	INSTANTER
BUFFERS -	SELF CONTAINED 406 DIA HEADS
WHEELS -	952 DIA.
JOURNALS -	203x114 (8" x 4 1/2") PLAIN BEARINGS

ISSUE 1

EX. GWR. DIAGRAM J 21

BOGIE RAIL WAGON

YY 017 B

LOT NUMBER	
838	
923	

TOPS INFORMATION					
AARKND	OPERATING	OPERATING SPEED		BRAKE FORCE DATA	EXCESS LENGTH —
CARKND	PANEL NO.	50 mile/h UP TO		NO POWER BRAKE	
Y Y P G	8 6 9 2	-mile/h ABOVE- 45 tonne GLW			

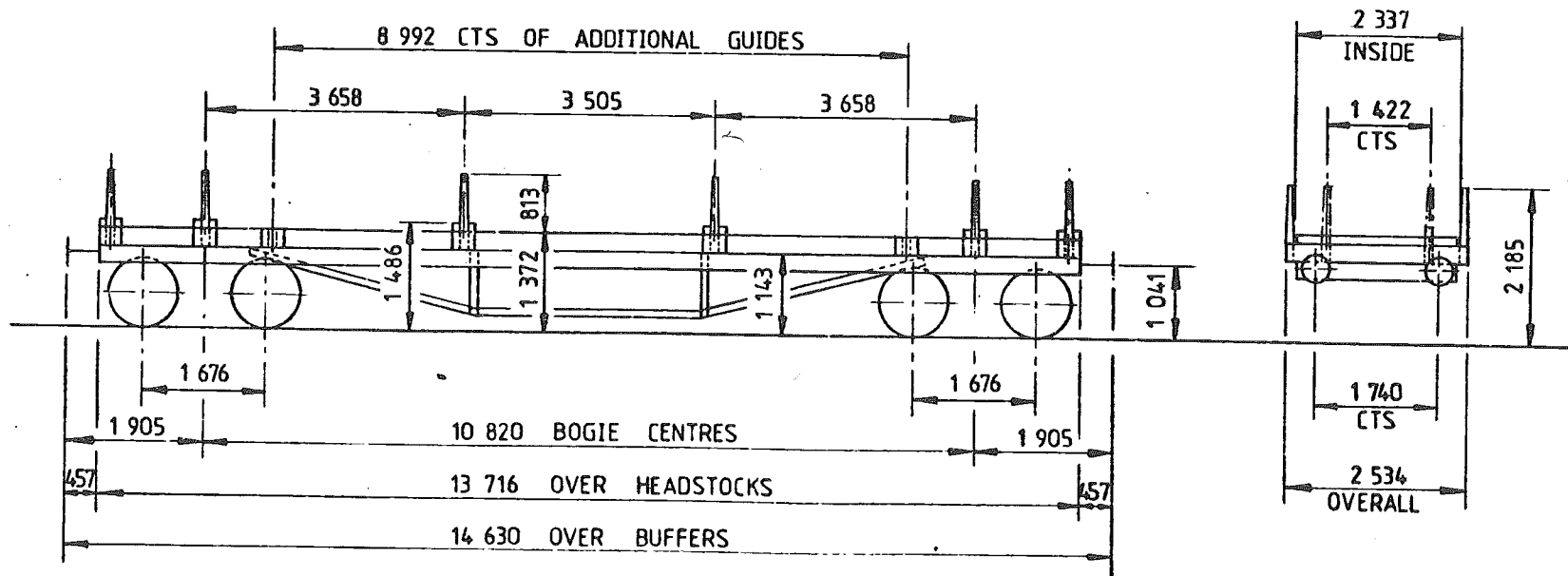

TARE -	15 ⁵⁰ kg
CAPACITY, WEIGHT -	30 ⁵⁰ kg
CAPACITY, VOLUME -	—
MIN. CURVE -	—
GEN. ARRGT. DRG. NO. -	—

BRAKE -	THROUGH VACUUM PIPE & HAND LEVER
SUSPENSION -	SECONDARY COIL
COUPLINGS -	INSTANTER
BUFFERS -	SELF CONTAINED 406 DIA HEADS
WHEELS -	952 DIA.
JOURNALS -	203x114(8"x4 1/2") PLAIN BEARINGS

ISSUE 1

EX. GWR. DIAGRAM J 21

BOGIE RAIL WAGON

YY 018 B

LOT NUMBER	
1014	

TOPS INFORMATION										
AARKND		OPERATING		OPERATING SPEED				BRAKE FORCE DATA		EXCESS LENGTH ---
CARKND		PANEL NO.		45 mile/h UP TO				NO POWER BRAKE		
Y	Y	P	G	8	7	5	4			

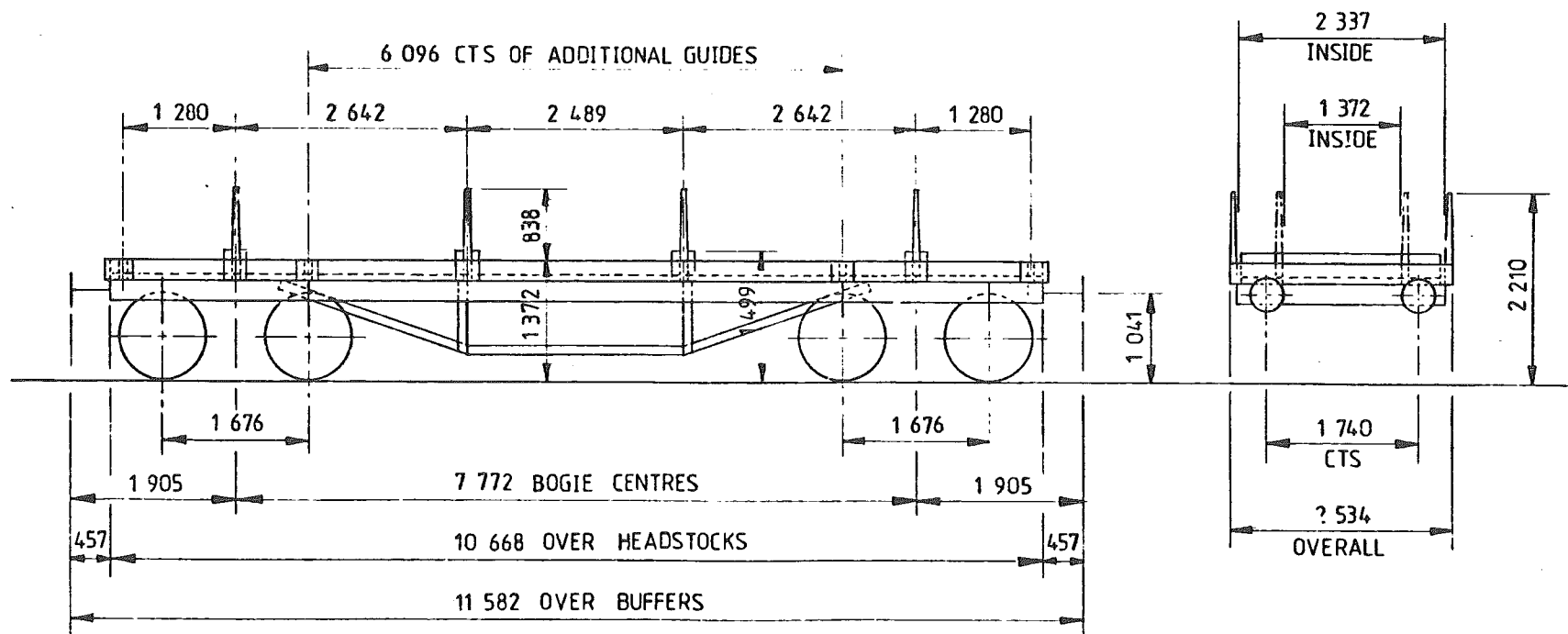

TARE -	15 ⁵⁰⁰ kg
CAPACITY, WEIGHT -	25 ⁵⁰⁰ kg
CAPACITY, VOLUME -	---
MIN. CURVE -	
GEN. ARRGT. DRG. NO. -	---

BRAKE -	THROUGH VACUUM PIPE & HAND LEVER
SUSPENSION -	SECONDARY COIL
COUPLINGS -	INSTANTER
BUFFERS -	SELF CONTAINED, 406 DIA. HEADS
WHEELS -	966 DIA.
JOURNALS -	

ISSUE 1

EX. GWR. DIAGRAM J 25

BOGIE BOLSTER WAGON

YY 019 A

LOT NUMBER	

TOPS INFORMATION						
AARKND	OPERATING		OPERATING SPEED		BRAKE FORCE DATA	EXCESS LENGTH 3
CARKND	PANEL NO.		50 mile/h UP TO		NO POWER BRAKE	
Y Y O G	0 0 2 6	mile/h ABOVE 45 tonne GLW				

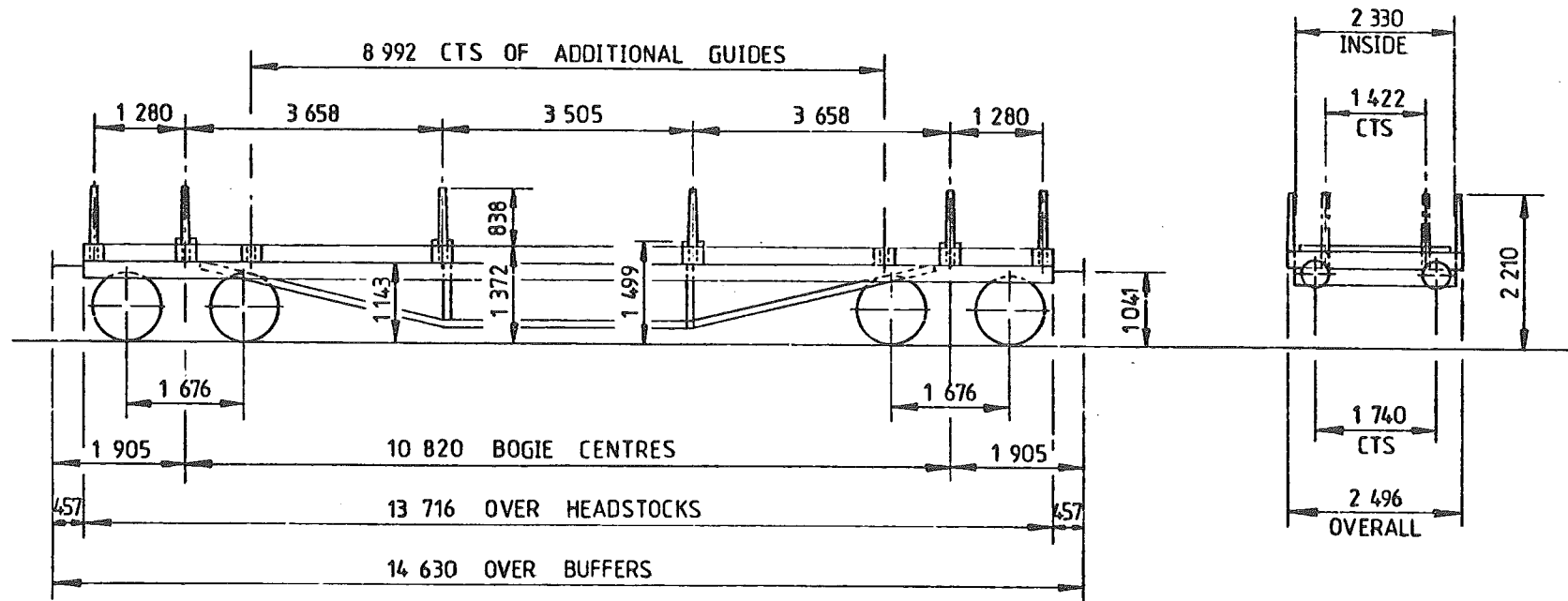

TARE -	15 ⁵⁵⁰ kg
CAPACITY, WEIGHT -	30 ⁵⁰⁰ kg
CAPACITY, VOLUME -	
MIN. CURVE -	
GEN. ARRGT. DRG. N ^o . -	

BRAKE -	HAND LEVER
SUSPENSION -	SECONDARY COIL
COUPLINGS -	INSTANTER
BUFFERS -	SELF CONTAINED 406 DIA. HEADS
WHEELS -	953 DIA.
JOURNALS -	203x114 (8" x 4 1/2") PLAIN BEARINGS

ISSUE 1

BOGIE RAIL WAGON

YY 021 A

LOT NUMBER	
1645	

TOPS INFORMATION													
AARKND		OPERATING		OPERATING SPEED			BRAKE FORCE DATA			EXCESS LENGTH			
CARKND		PANEL NO.		45 mile/h UP TO			14↑ FORCE UP TO				—		
Y	Y	V	G	8	7	3	3	— mile/h ABOVE 62 tonne GLW				↑ FORCE ABOVE 62 tonne GLW	

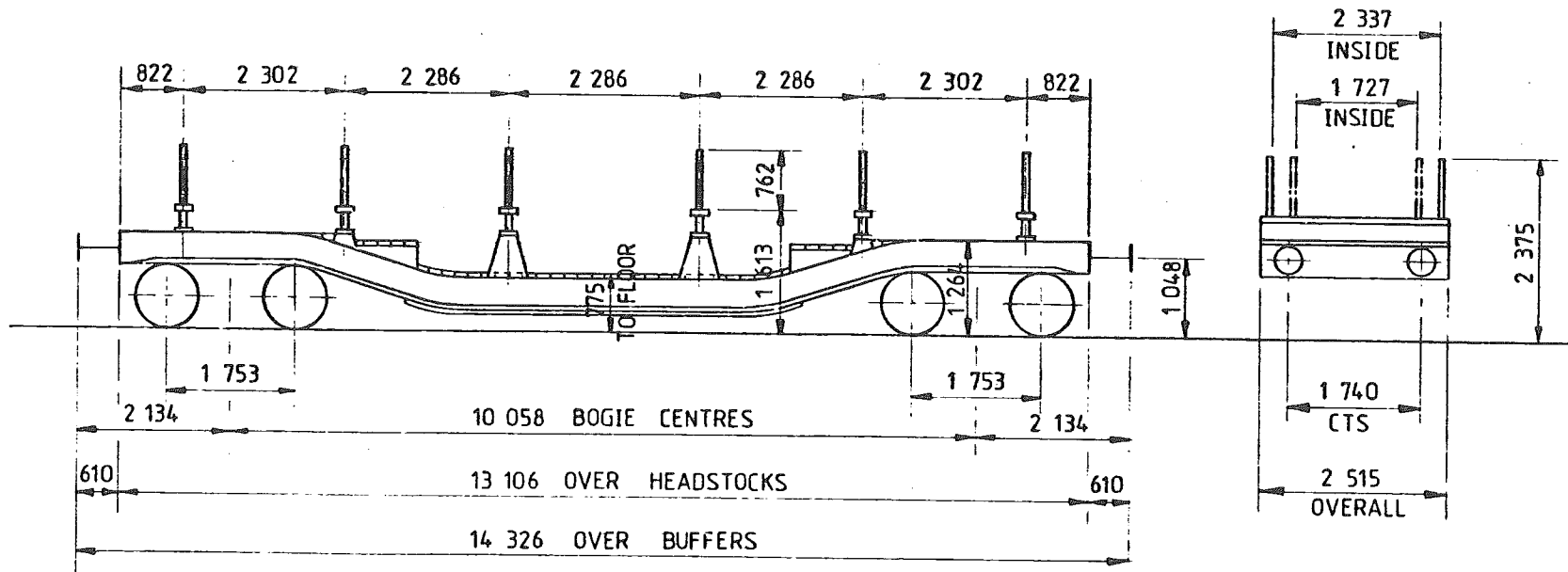

TARE -	30850kg
CAPACITY, WEIGHT -	30500kg
CAPACITY, VOLUME -	—
MIN. CURVE -	37m
GEN. ARRGT. DRG. N ^o . -	—

BRAKE -	VACUUM BLOCK & HAND SCREW
SUSPENSION -	SECONDARY COIL
COUPLINGS -	BR. SCREW
BUFFERS -	SELF CONTAINED, 400 DIA. HEADS
WHEELS -	838 DIA.
JOURNALS -	279x140(11"x5½") PLAIN BEARINGS

ISSUE 1

EX. GWR. DIAGRAM J 33

BOGIE BOLSTER WAGON

YY022B

LOT NUMBER	
1547	

TOPS INFORMATION						
AARKND	OPERATING	OPERATING SPEED		BRAKE FORCE DATA		EXCESS LENGTH
CARKND	PANEL NO.	45 mile/h UP TO		11 † FORCE UP TO		
Y Y V G	8 8 4 5	- mile/h ABOVE		† FORCE ABOVE		

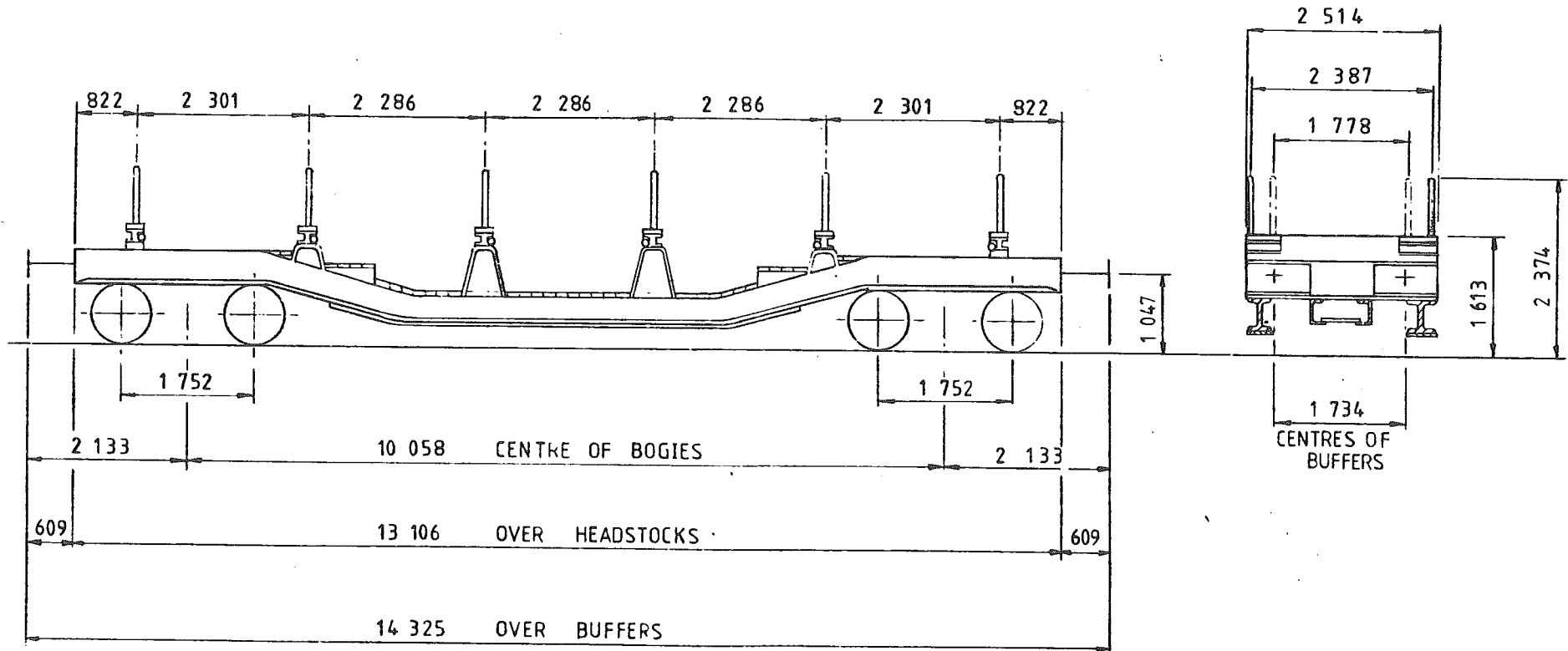

TARE -	29 ⁷⁰⁰ kg
CAPACITY, WEIGHT -	30 ⁵⁰⁰ kg
CAPACITY, VOLUME -	—
MIN. CURVE -	40m
GEN. ARRGT. DRG. NO. -	13/4058

BRAKE -	HAND SCREW & VACUUM BRAKE
SUSPENSION -	SECONDARY COIL
COUPLINGS -	BR. SCREW
BUFFERS -	SELF CONTAINED (533x330) OVAL HEAD
WHEELS -	838 DIA
JOURNALS -	280x140 (11x5½) PLAIN BEARINGS

ISSUE 1

EX. LMS DIAGRAM Z/058

BOGIE BOLSTER WAGON

YY023B

LOT NUMBER	
348	

TOPS INFORMATION						
AARKND	OPERATING		OPERATING SPEED	BRAKE FORCE DATA		EXCESS LENGTH
CARKND	PANEL NO.		45 mile/h UP TO	NO POWER BRAKE		
Y Y P G	8	7 0 8	- mile/h ABOVE	46tonne GLW		

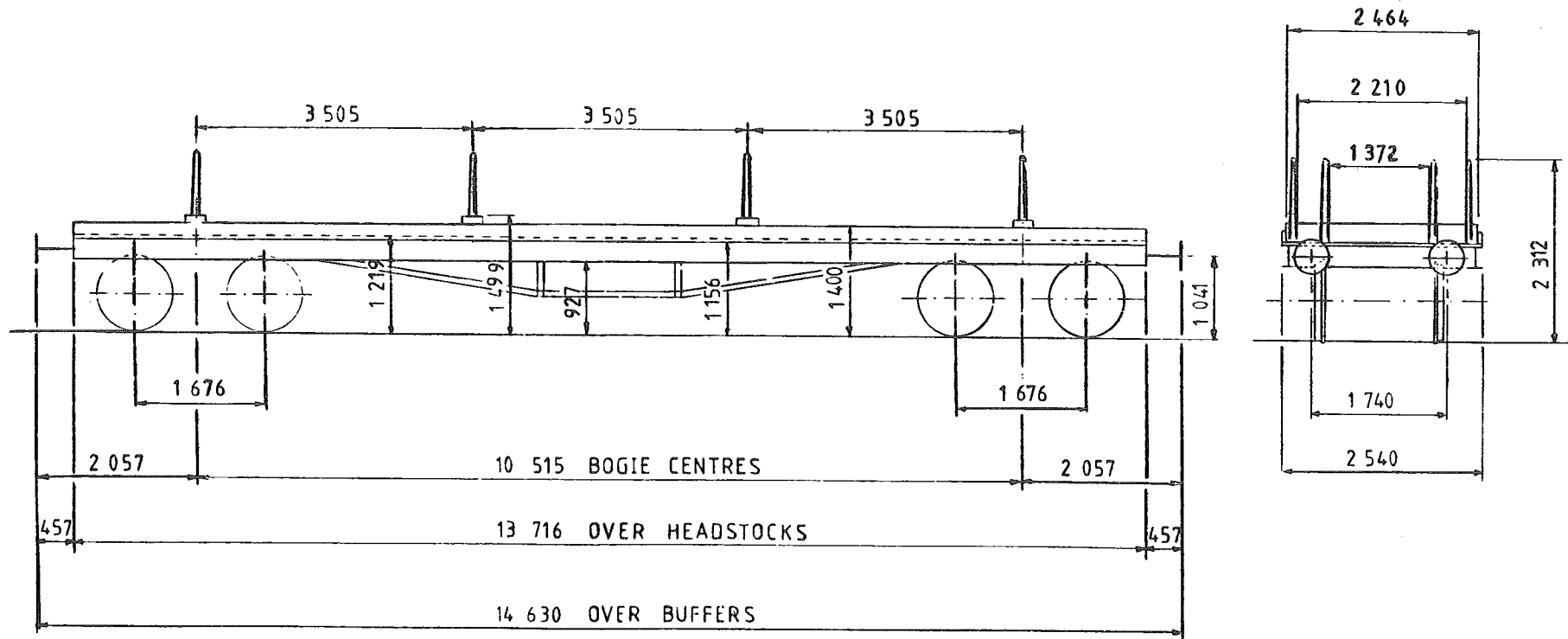

TARE -	14,800 Kg
CAPACITY, WEIGHT -	30,500 Kg
CAPACITY, VOLUME -	---
MIN. CURVE -	21m
GEN. ARRGT. DRG. N ^o . -	6468

BRAKE -	HAND LEVER
SUSPENSION -	SECONDARY COIL
COUPLINGS -	BR SCREW
BUFFERS -	SELF CONTAINED 457 DIA HEADS
WHEELS -	952 DIA
JOURNALS -	228 x 114 (9 x 4 1/2") PLAIN BEARINGS

ISSUE 1

EX LMS SPECIAL DIAGRAM 11

BOGIE BOLSTER WAGON

YY 027 B

LOT NUMBER	
—	

TOPS INFORMATION							
AARKND	OPERATING		OPERATING SPEED		BRAKE FORCE DATA		EXCESS LENGTH
CARKND	PANEL NO.		50 mile/h UP TO		NO POWER BRAKE		—
Y Y P G	8 7 3 2	mile/h ABOVE		59 tonne GLW			

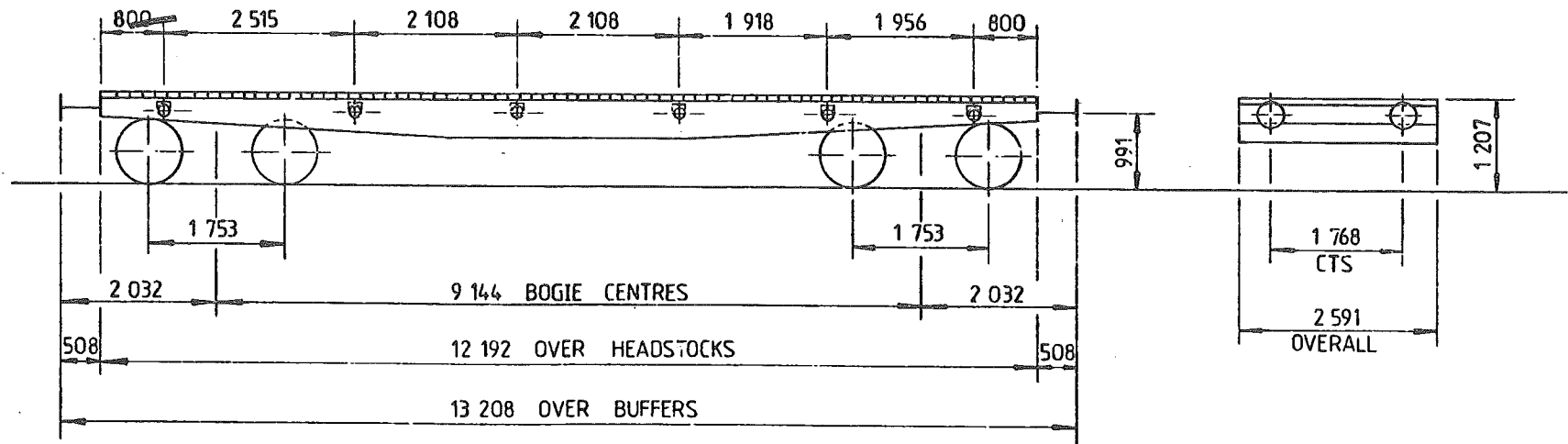

TARE -	18 ³⁰⁰ kg
CAPACITY, WEIGHT -	40 ⁶⁵⁰ kg
CAPACITY, VOLUME -	—
MIN. CURVE -	31m
GEN. ARRGT. DRG. N ^o -	—

BRAKE -	THROUGH VACUUM PIPE & HAND SCREW
SUSPENSION -	SECONDARY COIL
COUPLINGS -	BR. SCREW
BUFFERS -	SELF CONTAINED, 330 DIA. HEADS
WHEELS -	915 DIA.
JOURNALS -	280x140 PLAIN BEARINGS

ISSUE 1

BOGIE STEEL CARRIER

YY 028 A

LOT NUMBER	
LMS	1138

TOPS INFORMATION						
AARKND	OPERATING		OPERATING SPEED		BRAKE FORCE DATA	EXCESS LENGTH 11
CARKND	PANEL N ^o .		45 mile/h UP TO 40 mile/h ABOVE		NO POWER BRAKE	
Y Y P G	8 7 6 2	56 tonne GLW				

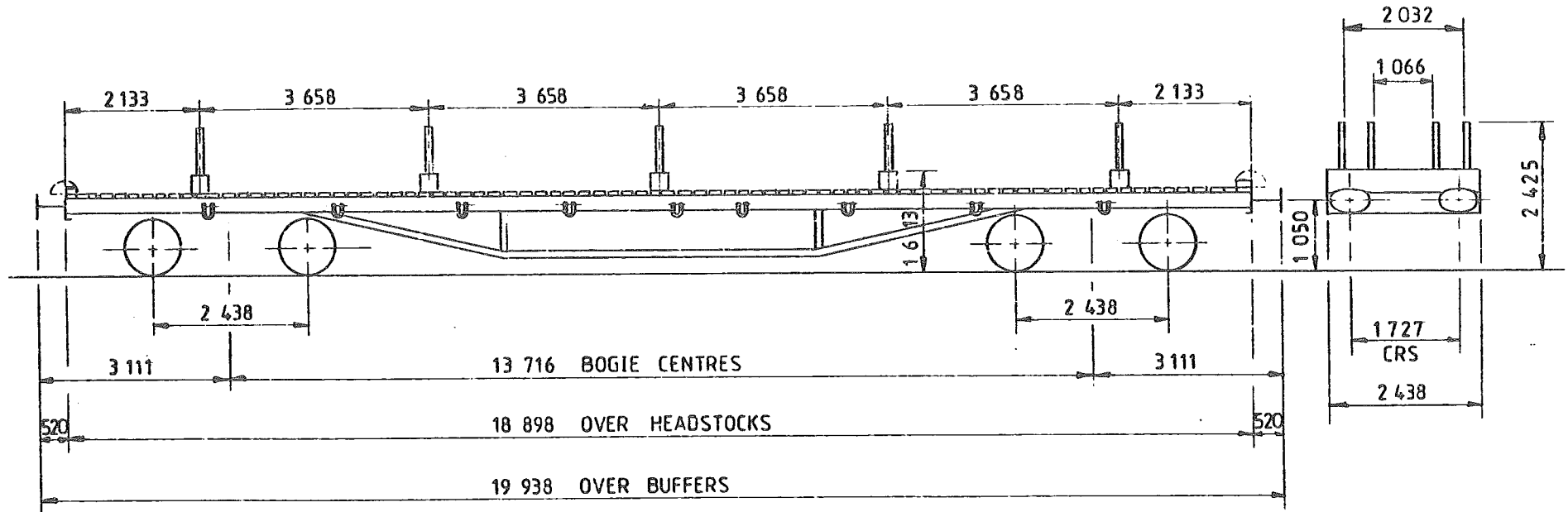

TARE -	24 900 kg
CAPACITY, WEIGHT -	51 000 kg
CAPACITY, VOLUME -	---
MIN. CURVE -	51 m
GEN. ARRGT. DRG. N ^o .	11/281

BRAKE -	HAND LEVER ON BOGIE & VAC. PIPE
SUSPENSION -	EYEBOLT & RUBBERS
COUPLINGS -	BR SCREW
BUFFERS -	SELF CONTAINED 559 x 356 OVAL HEADS
WHEELS -	825 DIA.
JOURNALS -	280 x 140, (11" x 5 1/2") PLAIN BEARINGS

ISSUE 1

EX. LMS DIAGRAM 19 B

BOGIE BOLSTER WAGON

YY 505 A

LOT NUMBER	

TOPS INFORMATION					
AARKND	OPERATING	OPERATING SPEED		BRAKE FORCE DATA	EXCESS LENGTH
CARKND	PANEL NO	45mile/h UP TO		NO POWER BRAKE	
YYOG	7066	mile/h ABOVE 60tonne GLW			

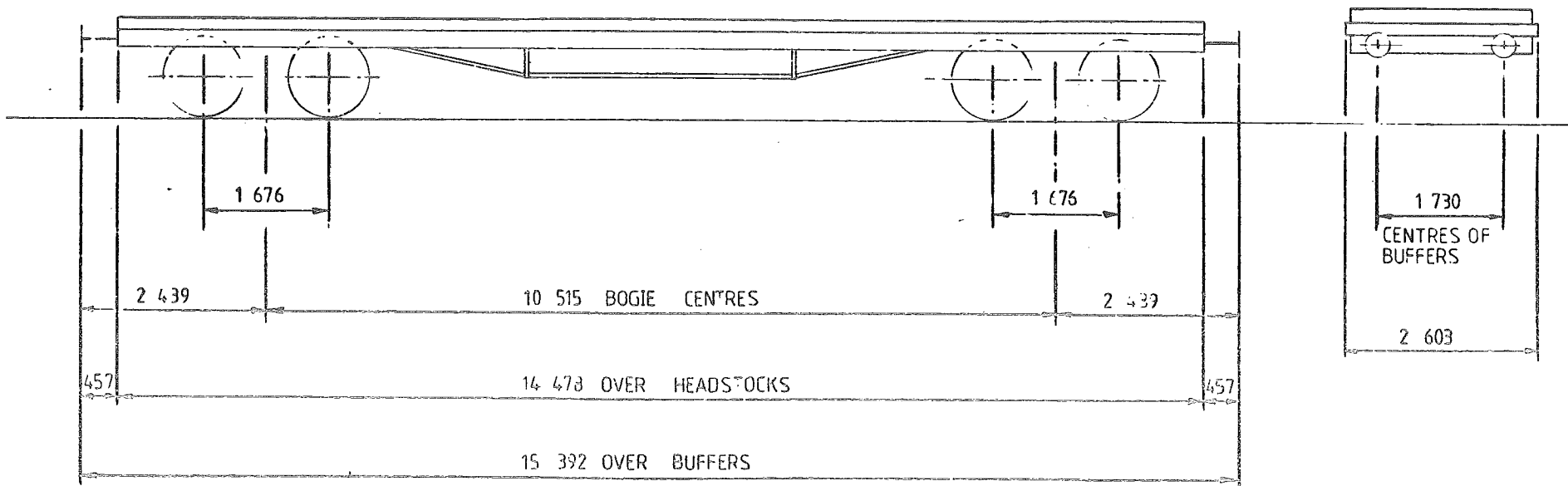

TARE -	18 ⁷⁵⁰ kg
CAPACITY, WEIGHT -	40 ⁵⁰⁰ kg
CAPACITY, VOLUME -	—————
MIN. CURVE -	
GEN ARRGT. DRG NO. -	

BRAKE -	HAND SCREW
SUSPENSION -	SECONDARY COIL
COUPLINGS -	INSTANTER
BUFFERS -	RUBBER SPRINGS DIA 406 x 457
WHEELS -	952 DIA
JOURNALS -	254 x 127 (10 x 5) PLAIN BEARINGS

ISSUE 1

EX SR DIAGRAM 1597