

BRITISH RAILWAYS
COACHING STOCK

DIAGRAM BOOK

Diesel Multiple Unit Trains (Railcars)

© COPYRIGHT NOTICE

This PDF file has been created from the original book with permission of BRB Residuary Ltd who, retain copyright in the original document.

The original book was provided courtesy of Clive Mortimore.

This PDF version by David Faulkner, 2010.

Individuals may: use, retain and print out this PDF version for their private information or for that of their non-commercial enthusiast society or railway club.

This document and any copies produced from it in any form may not be sold or lent for any payment in any form other than to cover copying or transmission costs. No reproduction permitted in any other form or circumstance without prior permission from the original copyright holder

Replaces Dia B.R. 534

BATTERY RAILCAR.

B. R.406.

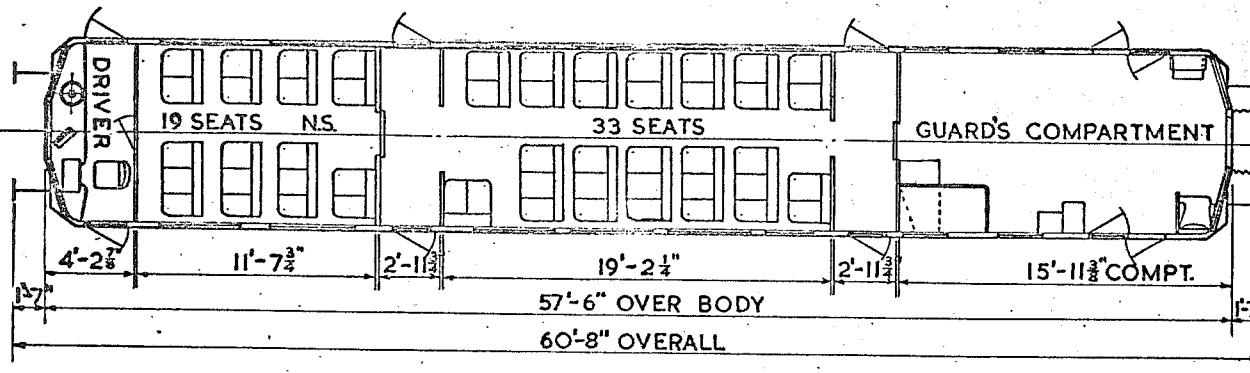
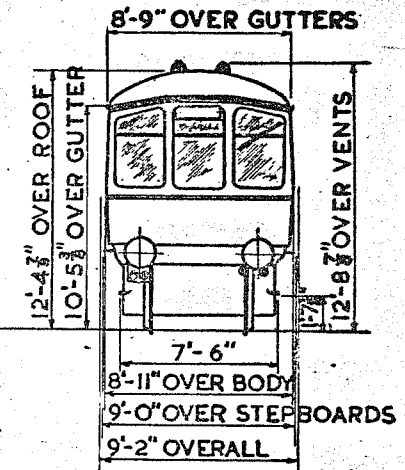
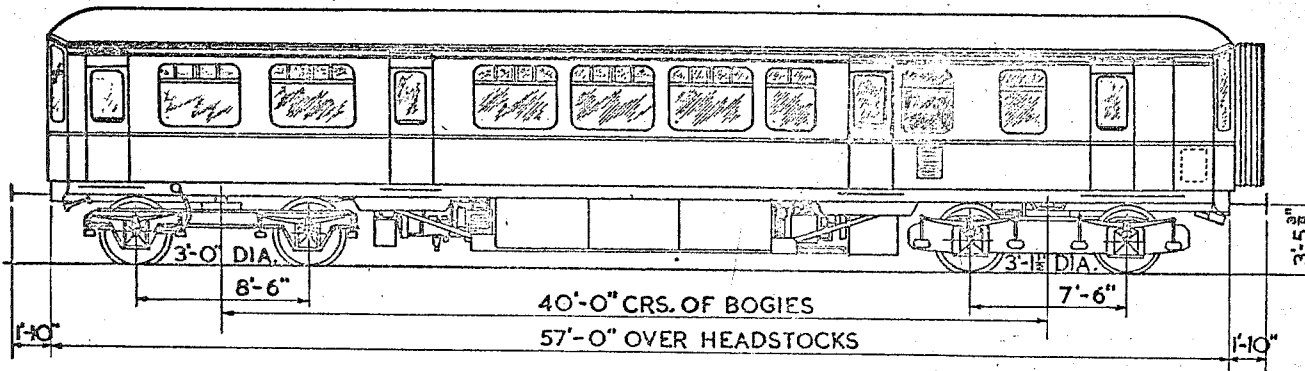

MOTOR SECOND BRAKE. LOT 30368

52 SEATS

No. S.C. 79998

TARE 37 1/2 T

Replaces Dia BR 535 3/11/59

BATTERY RAILCAR.

B. R. 442.

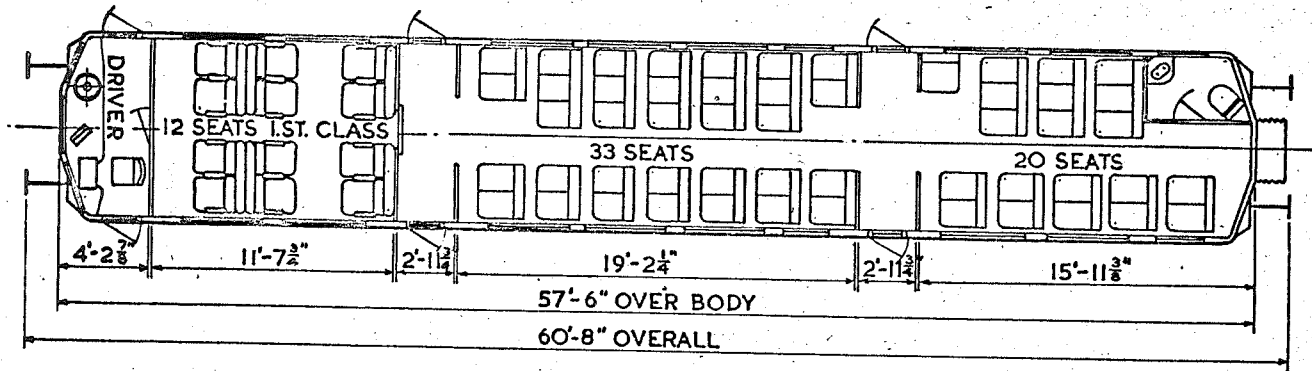
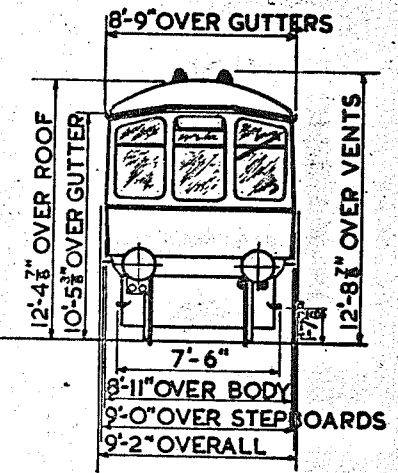
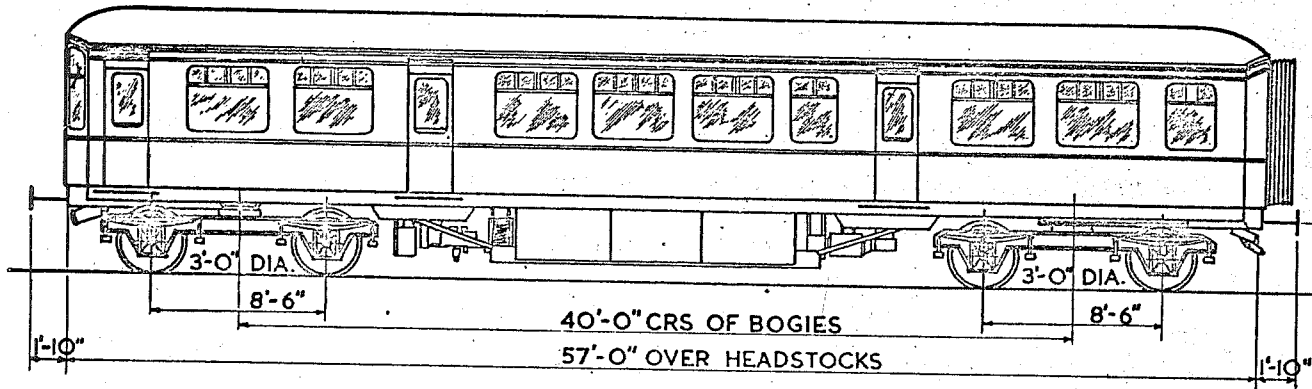

DRIVING TRAILER LAVATORY COMPOSITE. LOT. 30369.

SEATING 53 SECOND CLASS.

NO. SC. 79999.

12 FIRST CLASS.

TARE 32 1/2 T.

GANGWAYED MOTOR OPEN SECOND BRAKE.

BR. 501.

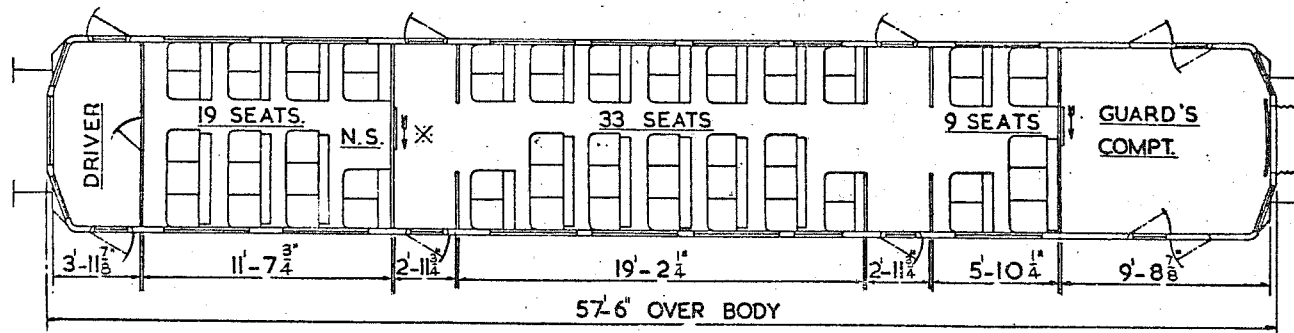
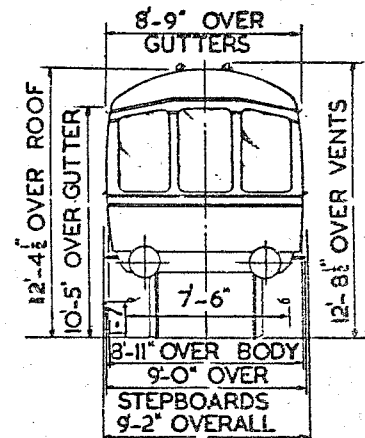
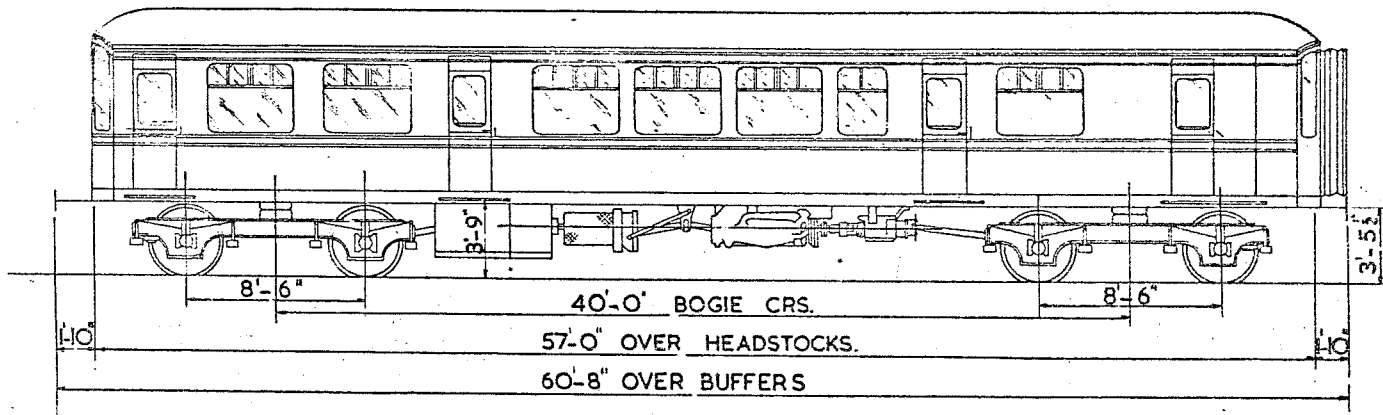

N.S. NON-SMOKING

* VEHICLE No. 79000 HAS DRAUGHT SCREENS HERE INSTEAD OF DOOR.

3 SECONDS - 61 SEATS.
 1 GUARD & LUGGAGE COMPT.
 1 DRIVING COMPT.

2 X 125 H.P. LEYLAND ENGINES
 WITH TORQUE CONVERTOR.

QTY.	LOT.	VEHICLE Nos.	BUILT AT	TARE.
8.	30084.	E79000-79007.	DERBY.	26 T

GANGWAYED MOTOR OPEN COMPOSITE

B. R. 502

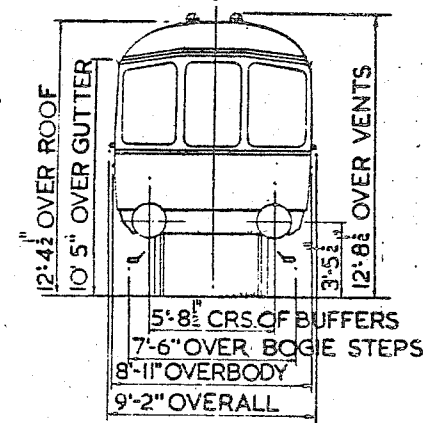
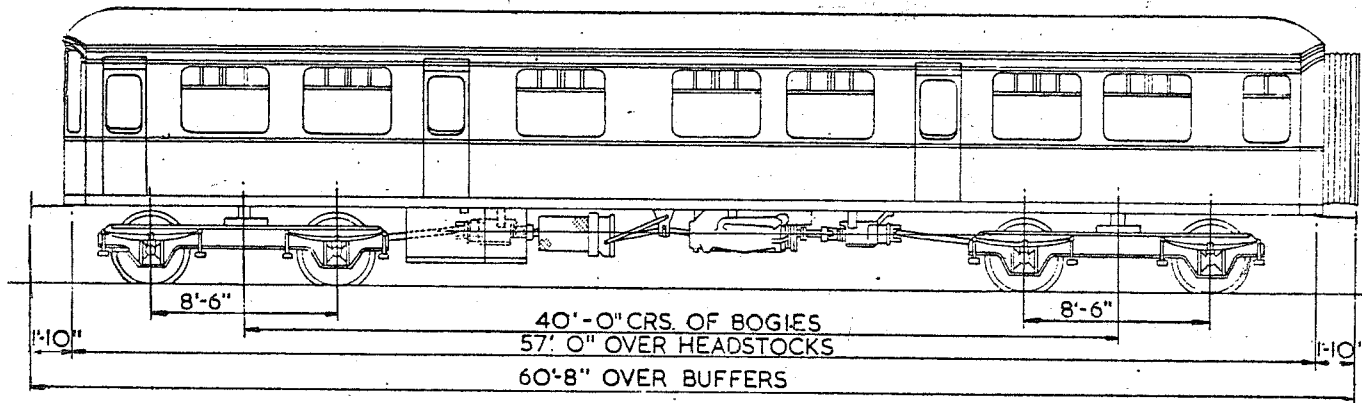

F - FIXED SEATS
R - REVERSIBLE SEATS

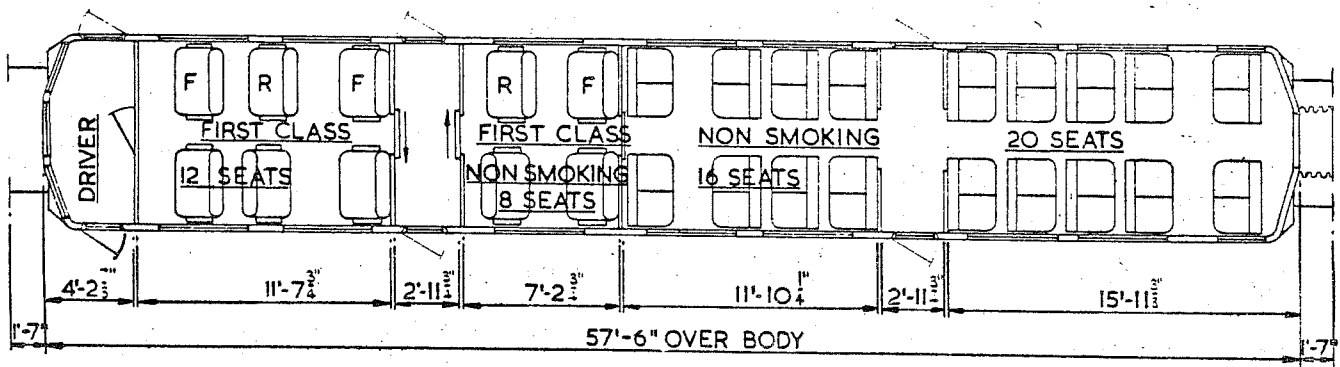

2 FIRSTS - 20 SEATS
2 SECONDS - 36 SEATS
1 DRIVING COMPARTMENT

2 X 150 H.P. A.E.C. ENGINES

<u>QTY.</u>	<u>LOT.</u>	<u>VEHICLE NoS.</u>	<u>BUILT AT.</u>	<u>TARE.</u>
30192.	E79508-E79512.	DERBY.	27T.	

GANGWAYED MOTOR OPEN SECOND BRAKE.

B.R. 503

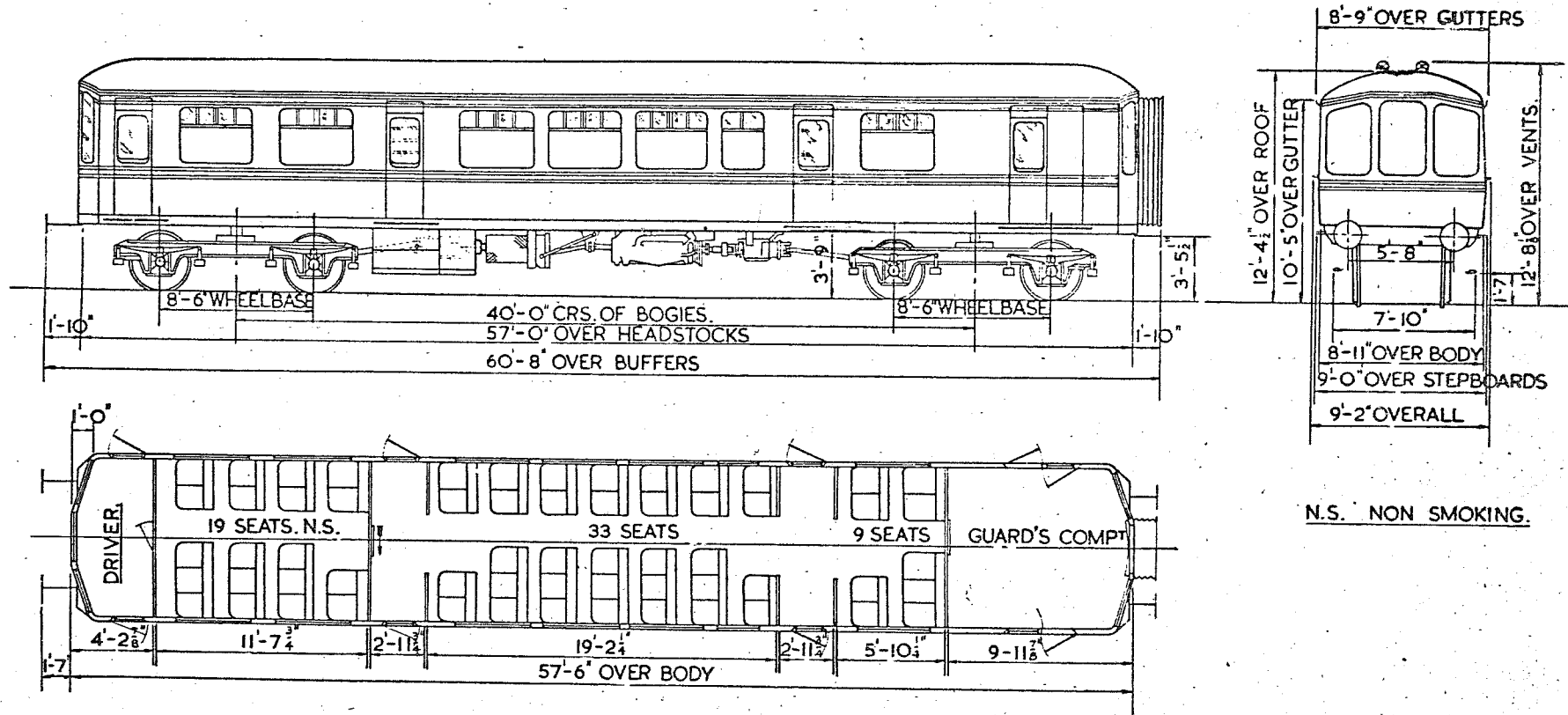

N.S. NON SMOKING.

3 SECONDS - 61 SEATS

2 X 150 H.P. A.E.C. ENGINES.

QTY.

LOT

VEHICLE Nos.

BUILT AT

TARE

1 LUGGAGE & GUARDS COMPARTMENT

13

23

M79008-M79020

DERBY

27 T

1 DRIVING COMPARTMENT

GANGWAYED MOTOR OPEN SECOND BRAKE.

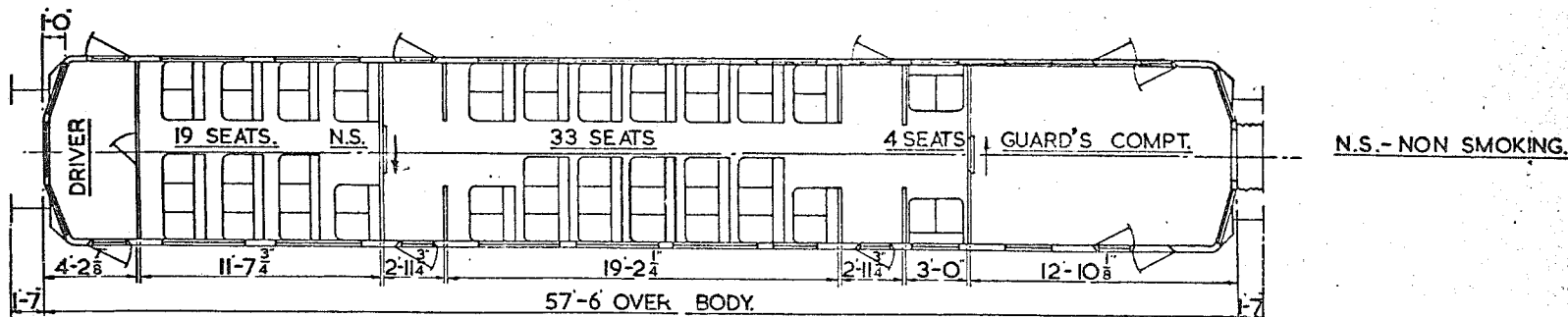
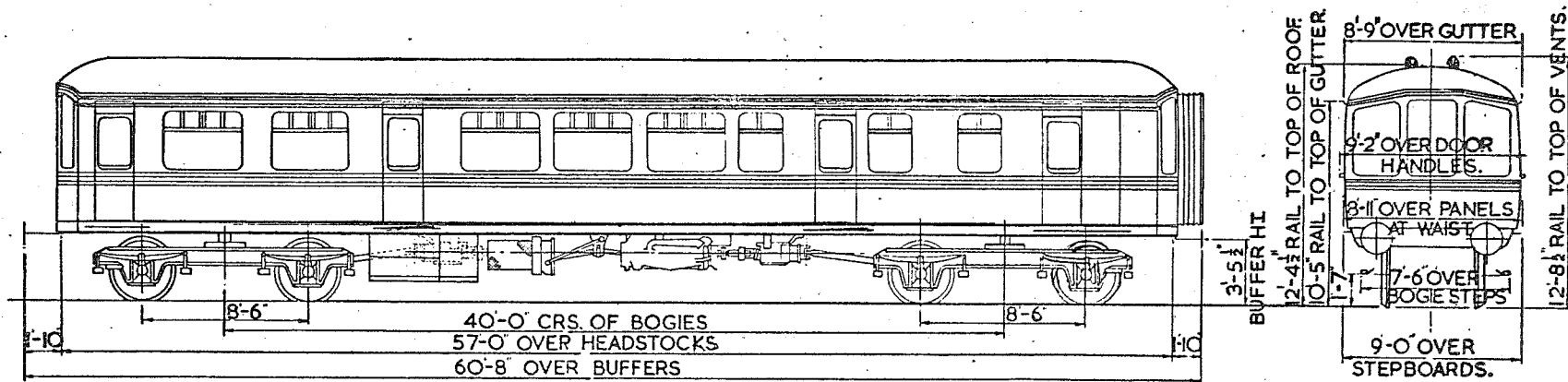

3 SECONDS 56 SEATS.
 1 GUARD & LUGGAGE COMPT.
 1 DRIVING COMPT.

2x150 H.P. A.E.C. ENGINES.

QTY	LOT	VEHICLE Nos.	BUILT AT	TARE
13	30126	E79021-E79033	DERBY	27T
13	30177	E 34-E79046	DERBY	27T

GANGWAYED DRIVING TRAILER LAVATORY COMPOSITE.

B.R. 505.

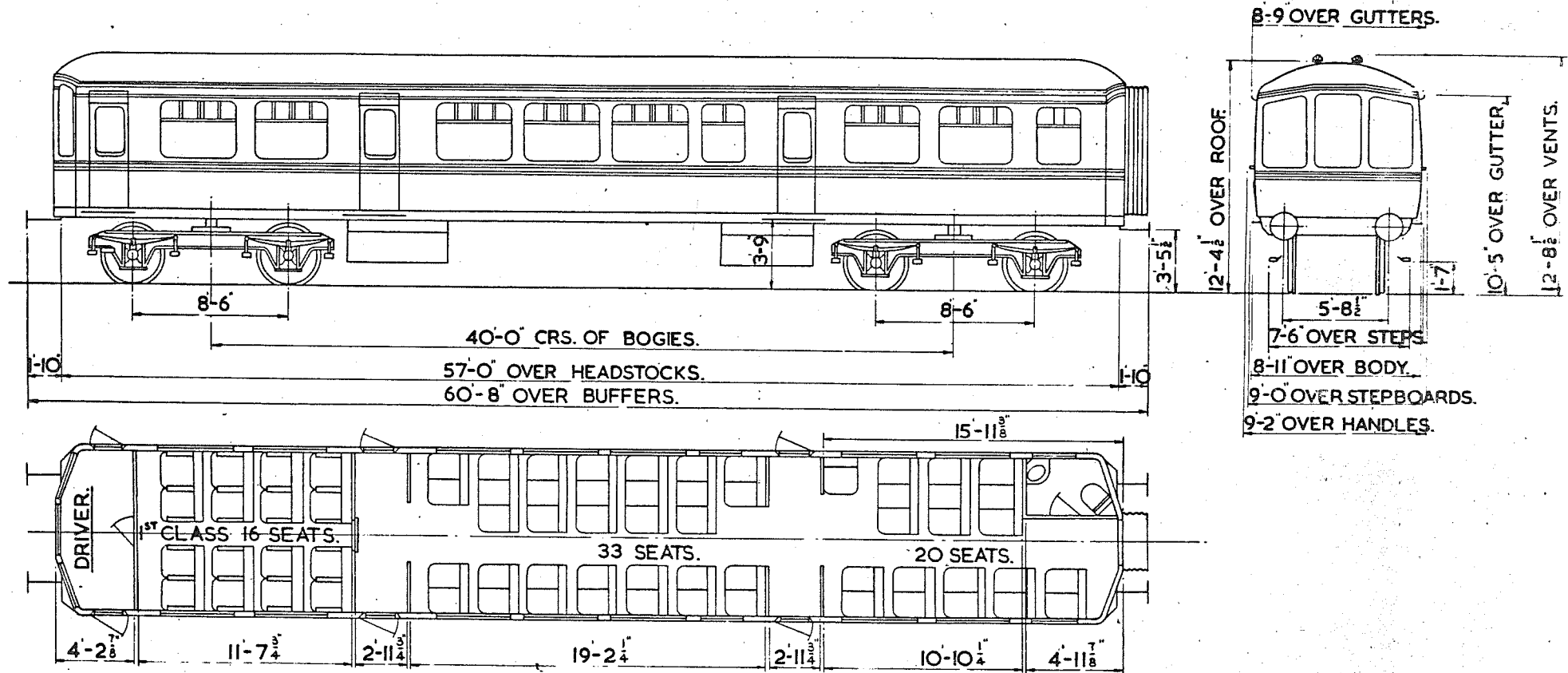

- 1 FIRST - 16 SEATS.
- 2 SECONDS - 53 SEATS.
- 1 DRIVING COMPARTMENT.
- 1 LAVATORY.

QTY.	LOT No.	VEHICLE Nos.	BUILT AT	TARE
13	30127.	E 7900 - E 79625.	DERBY.	21 T.
13	30178.	E 79250 - E 79262.	DERBY.	21 T.

GANGWAYED MOTOR OPEN LAVATORY COMPOSITE

B.R. 507

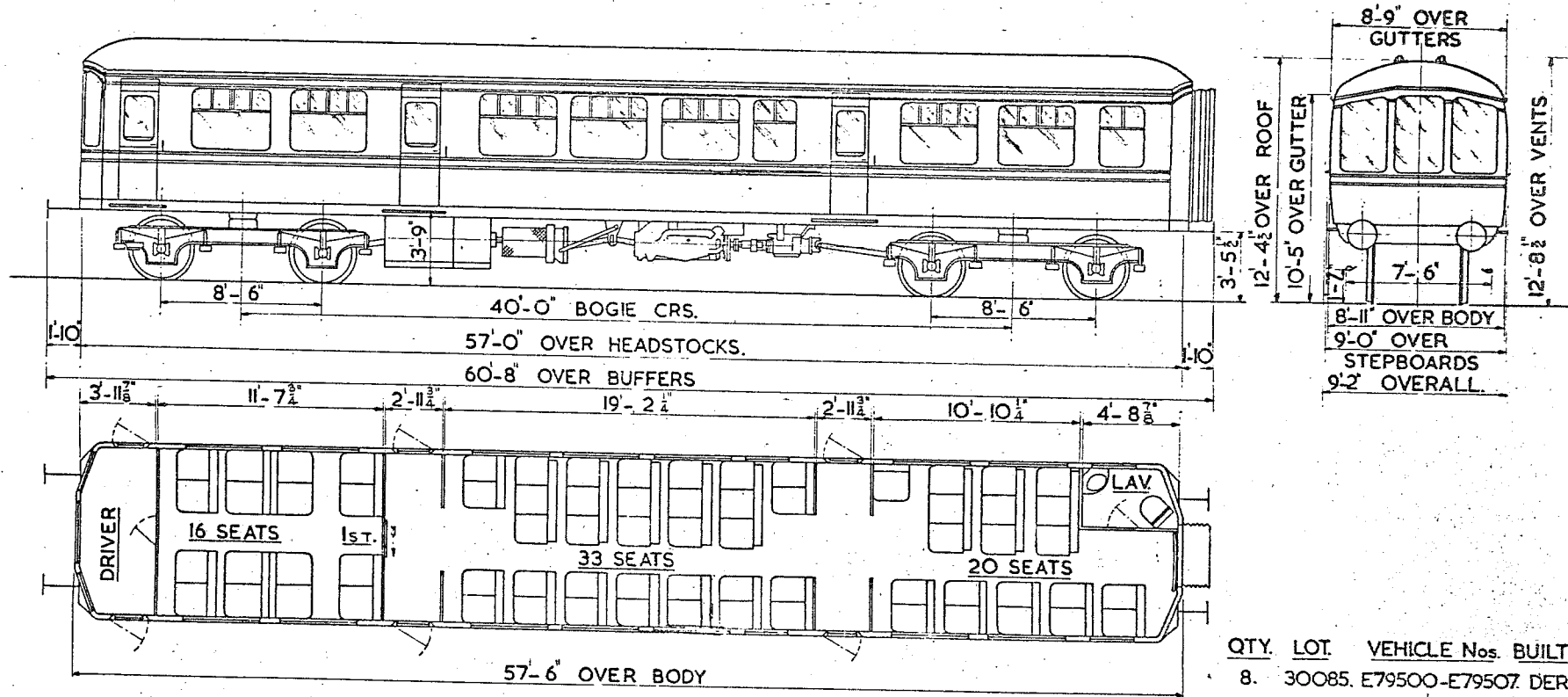

1 FIRST - 16 SEATS.
 2 SECONDS - 53 SEATS.
 1 DRIVING COMPT.
 1 LAVATORY.

2 X 125 H.P. LEYLAND ENGINES
 WITH TORQUE CONVERTOR.

QTY.	LOT.	VEHICLE Nos.	BUILT AT.	TARE.
8.	30085.	E79500-E79507.	DERBY	27T.

GANGWAYED TRAILER OPEN SECOND BRAKE

B. R. 508

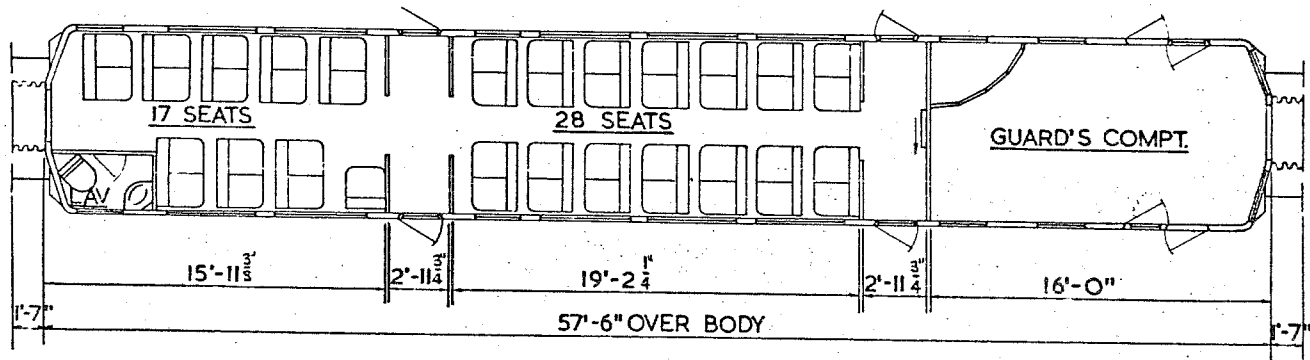
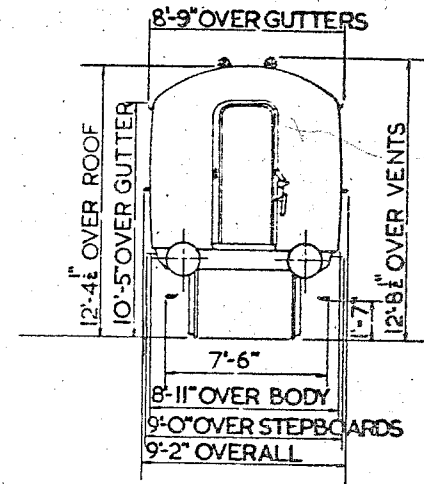
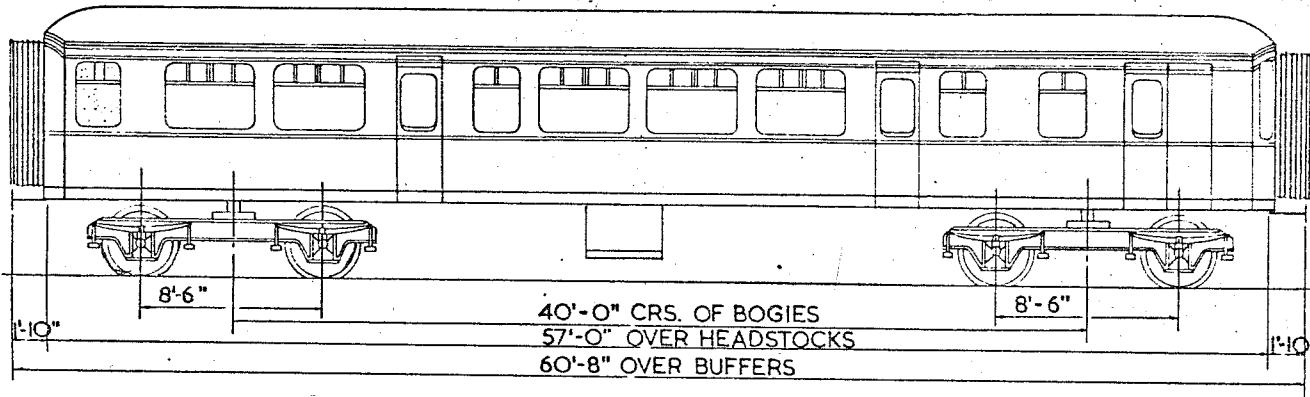

2 SECONDS - 45 SEATS
 1 GUARD & LUGGAGE COMPT.
 1 LAVATORY

QTY	LOT	VEHICLE NoS	BUILT AT	TARE
5	194	E79325 - E79329	DERBY	21T

GANGWAYED DRIVING TRAILER OPEN LAVATORY COMPOSITE

BR. 509.

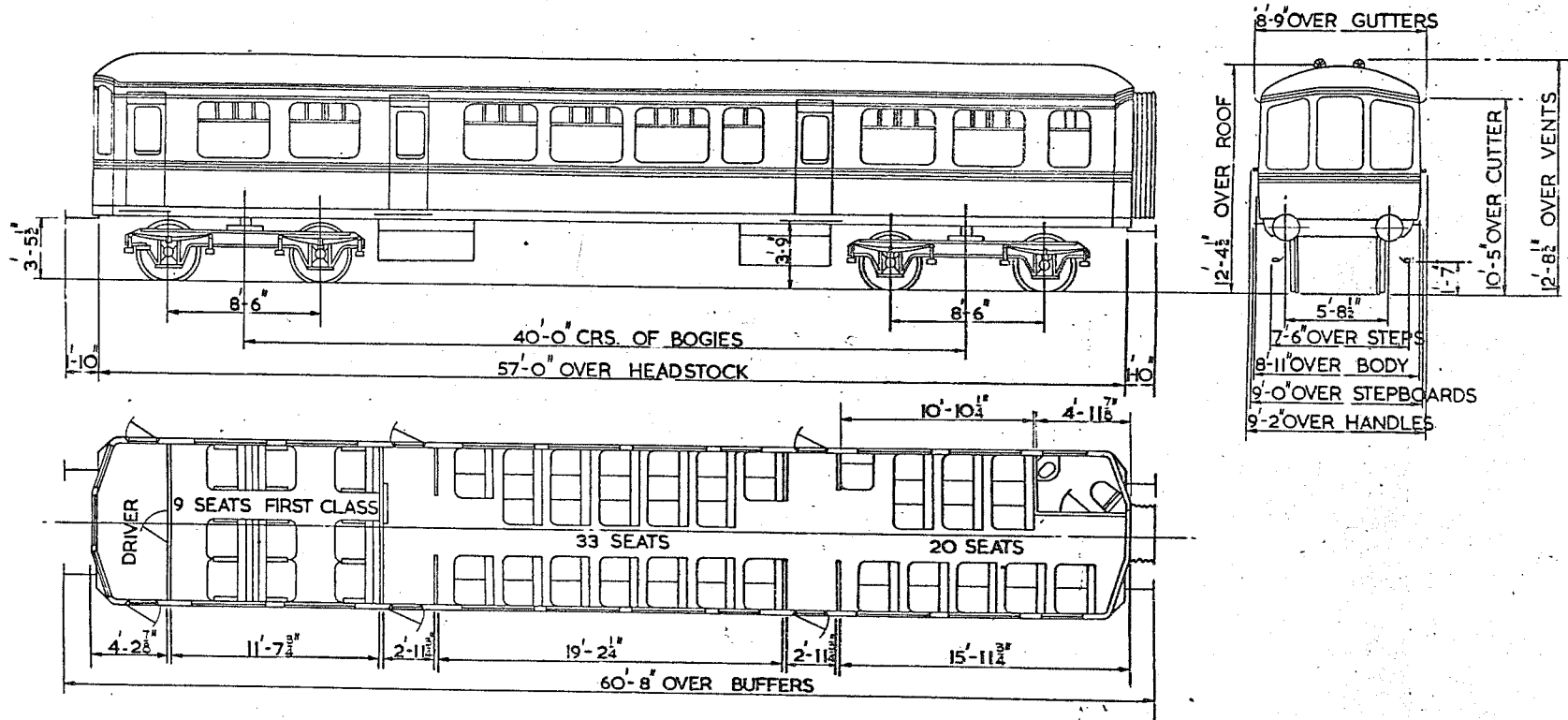

- 1 FIRST - 9 SEATS
- 2 SECOND- 53 SEATS
- 1 LAVATORY
- 1 DRIVING COMPARTME.

QTY.	LOT.	VEHICLE No.	BUILT.	TARE.
13	30124.	M.79600-M.79612	DERBY	21T.
9	30125.	M.79639 - M.79647	DERBY	21T.
10	302...	M.79648 - M.79657	DERBY	21T.
53	30325.	M.79633 - M.79637	DERBY	21T.

GANGWAYED MOTOR OPEN COMPOSITE LAVATORY.

B.R. 510

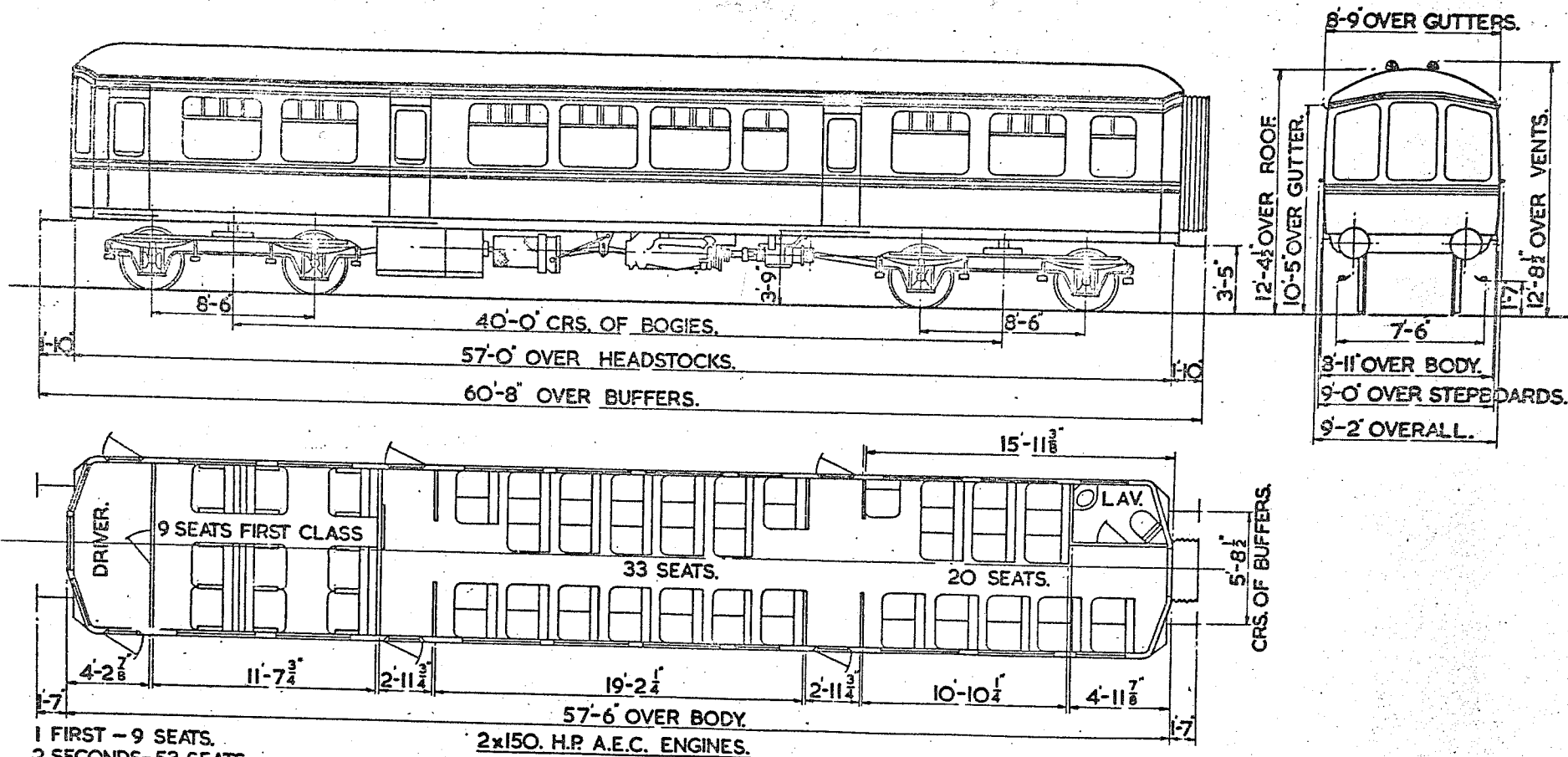

- 1 FIRST - 9 SEATS.
- 2 SECONDS - 53 SEATS.
- 1 DRIVING COMPARTMENT.
- 1 LAVATORY.

2x150. H.P. A.E.C. ENGINES.

Q	PART LOT.	VEHICLE No.	BUILT	TARE
2	30325	M79189-M79190	DERBY	27T

GANGWAYED DRIVING TRAILER LAVATORY COMPOSITE

B.R.511.

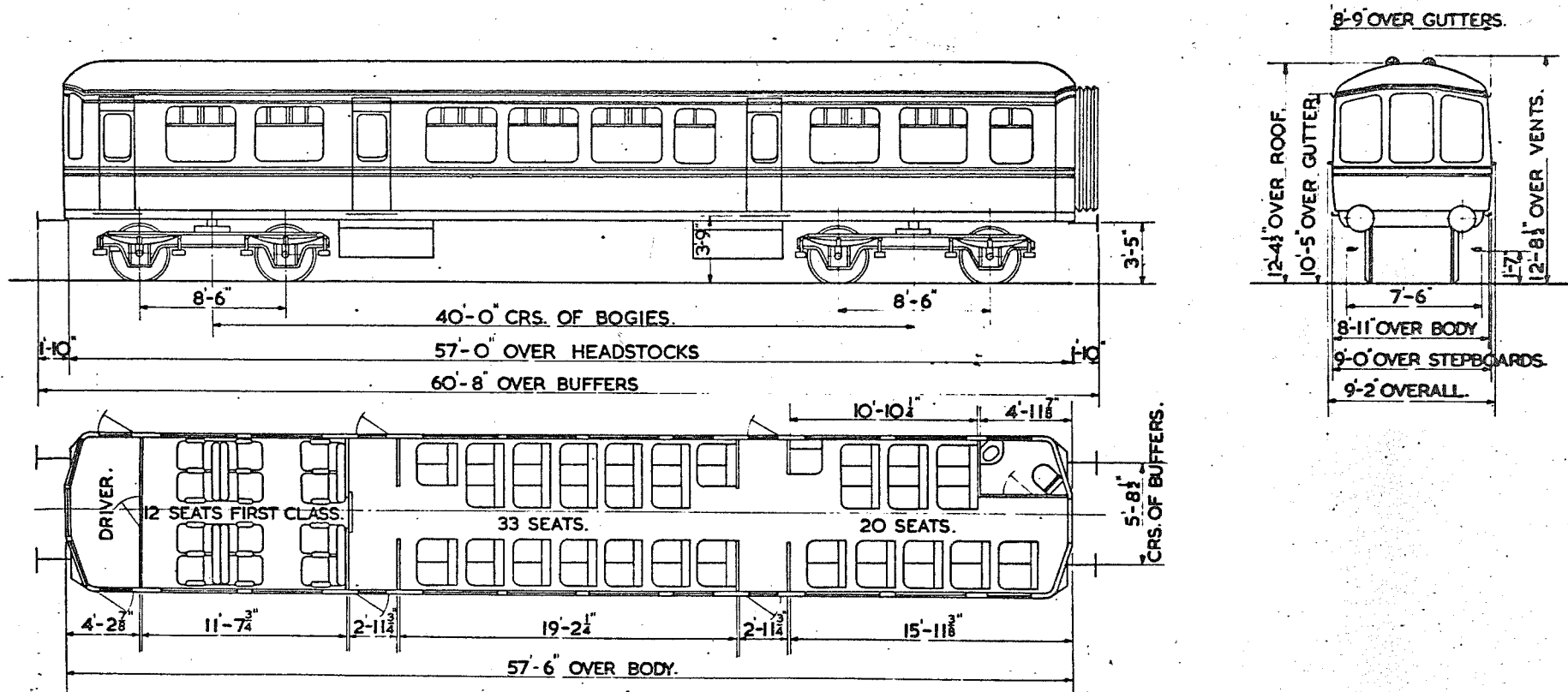

- 1 FIRST - 12 SEATS
- 2 SECONDS - 53 SEATS
- 1 DRIVING COMPT
- 1 LAVATORY

QTY.	LOT.	VEHICLE Nos.	BUILT AT	TARE.
15	30322	M 79670-M 79684	DERBY	21T.

NON - GANGWAYED MOTOR OPEN SECOND BRAKE

B.R. 512

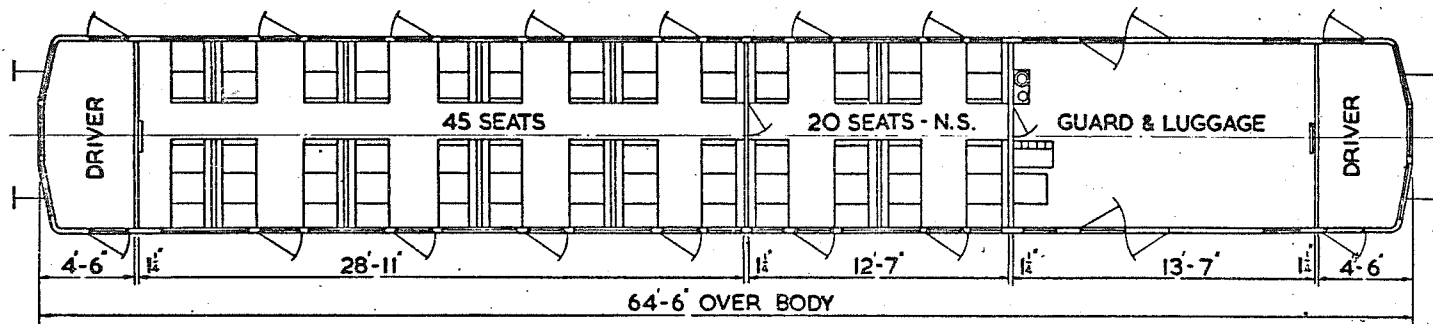
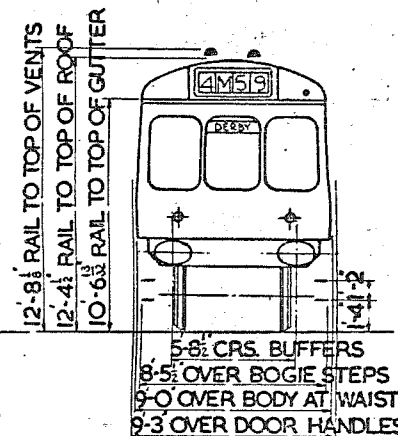
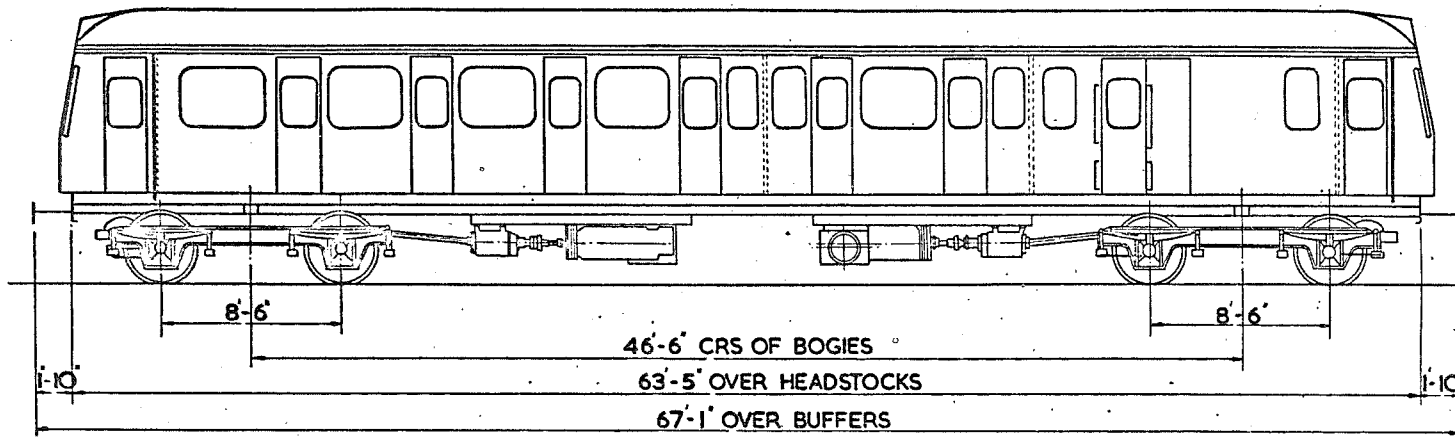

N.S. - NON-SMOKING

2 SECONDS. 65 SEATS
 2 DRIVING COMPARTMENTS
 1 GUARD & LUGGAGE

2 X 150 HP B.U.T. ENGINES.

QTY. 16
 LOT No. 518
 VEHICLE No. W55020-W55035

BUILT AT TARE
 PRESSED STEEL 37 T. 8 C.

NON GANGWAYED DRIVING TRAILER OPEN SECOND

B.R. 513

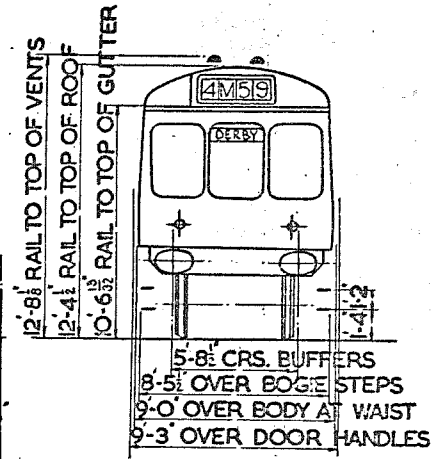
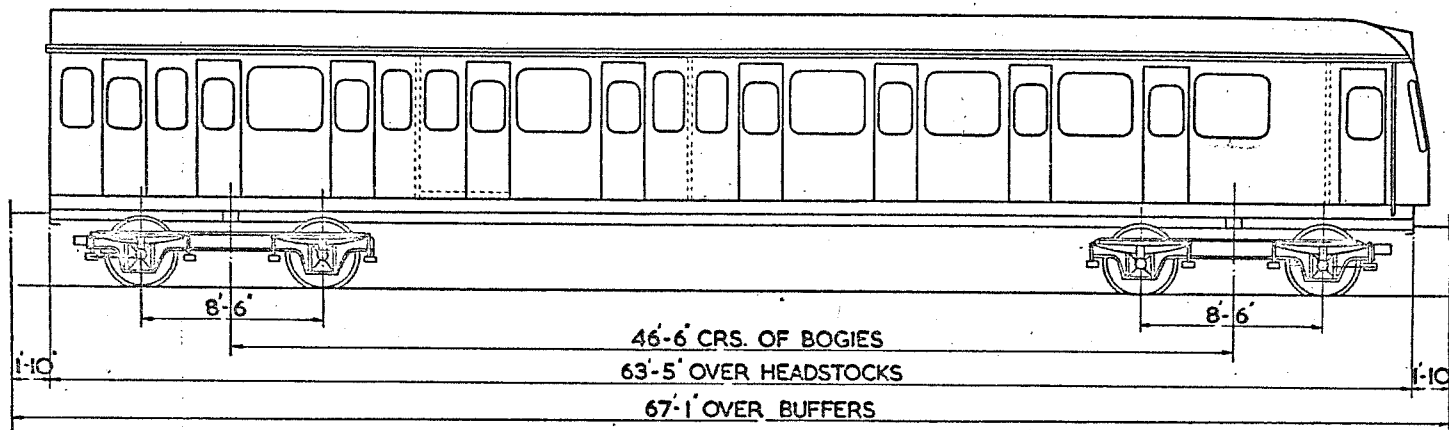

5'-8" CRS. BUFFERS
8'-5" OVER BOGIE STEPS
9'-0" OVER BODY AT WAIST
9'-3" OVER DOOR HANDLES

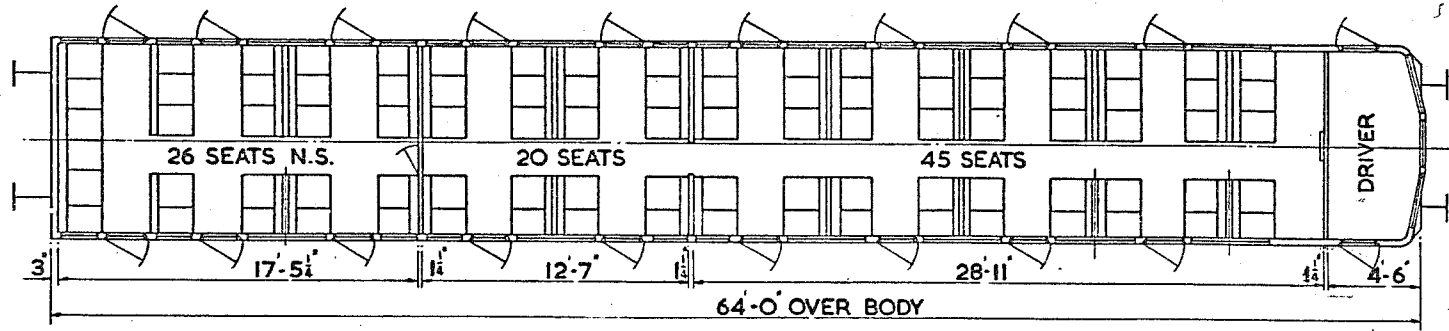

N.S. - NON-SMOKING

3 SECONDS 91 SEATS
1 DRIVING COMPARTMENT

QTY.	LOT No	VEHICLE Nos	BUILT AT	TARE
10	30519	W56280-W56289	PRESSED STEEL	29T. 7C.

SINGLE OPERATING UNIT No. 1

B.R. 514

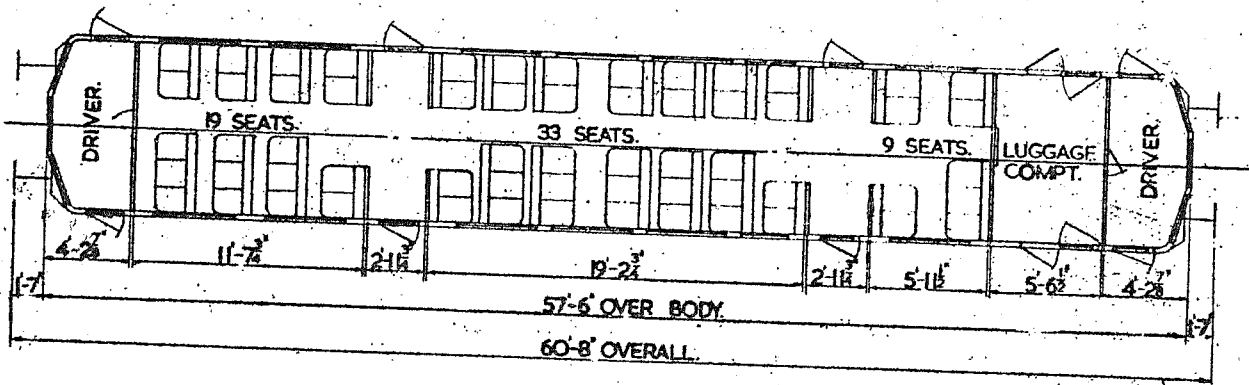
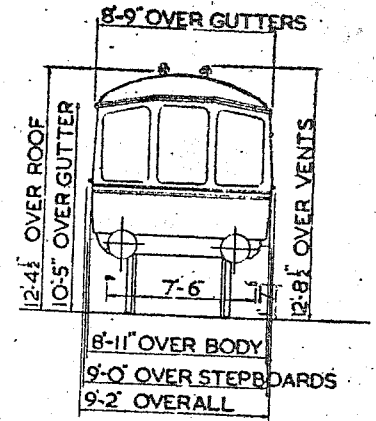
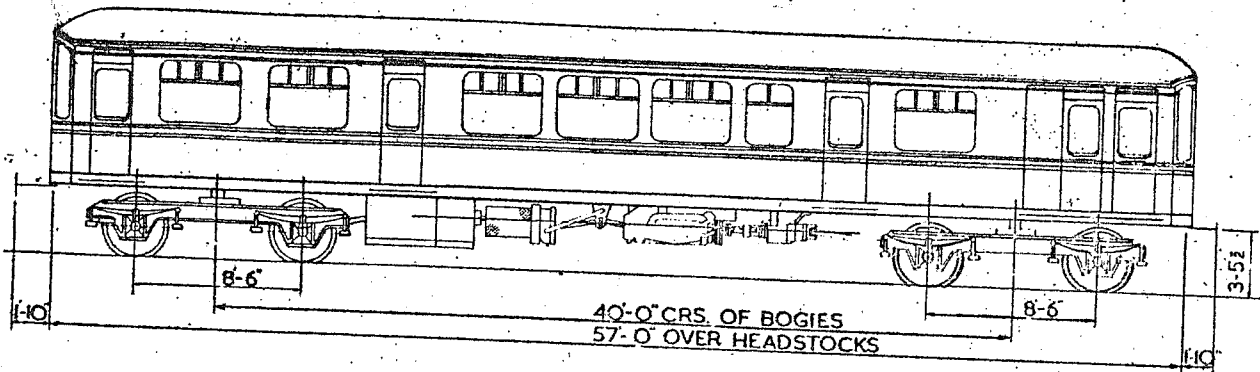

MOTOR THIRD BRAKE LOT. 30380
61 SEATS No. M79900
TARE 27T.

SINGLE OPERATING UNIT No. 2

B.R. 515

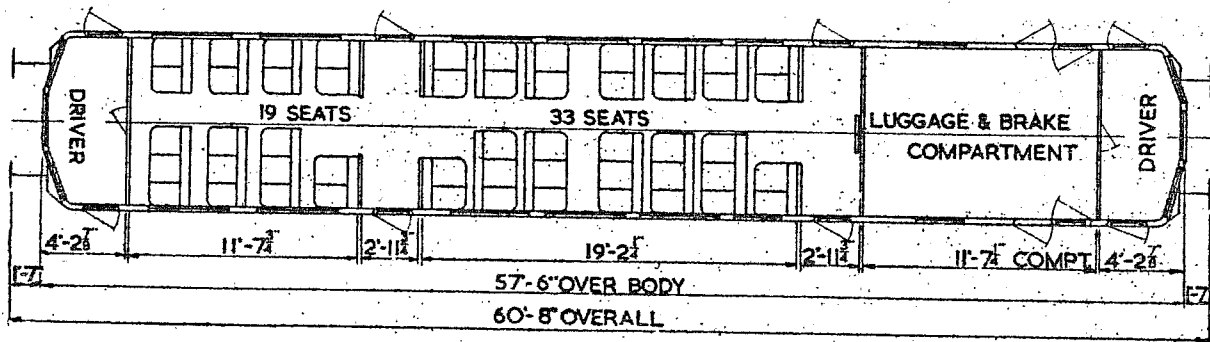
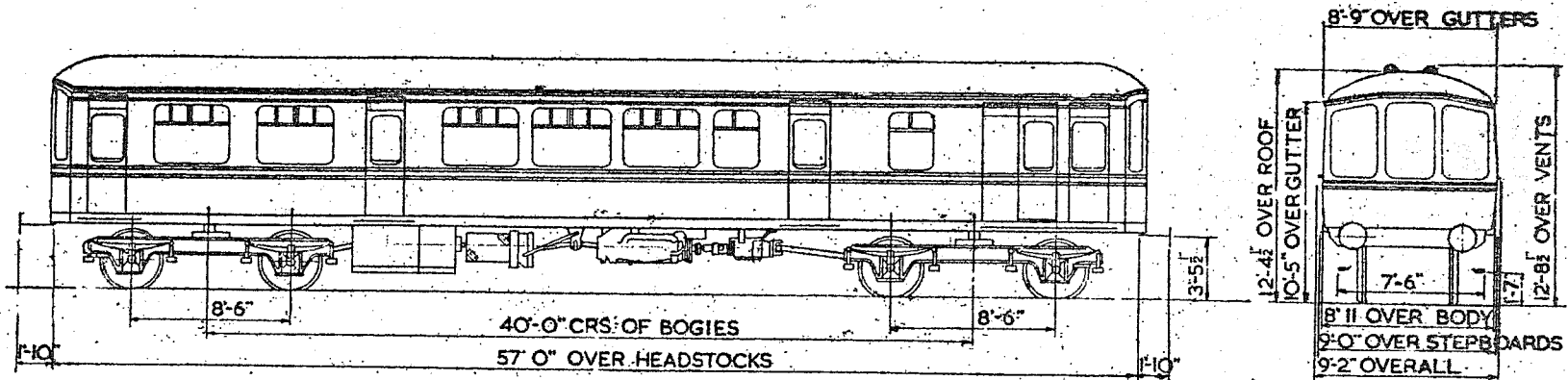

MOTOR THIRD BRAKE . LOT 30387

52 SEATS

No. M79901

TARE 27T

GANGWAYED MOTOR OPEN SECOND BRAKE.

B.R. 516.

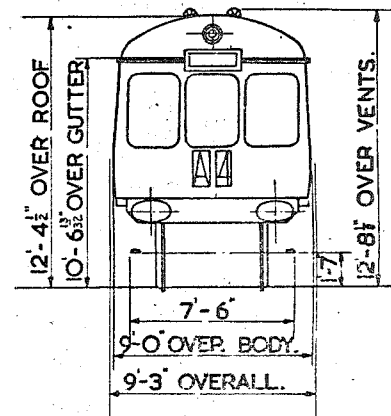
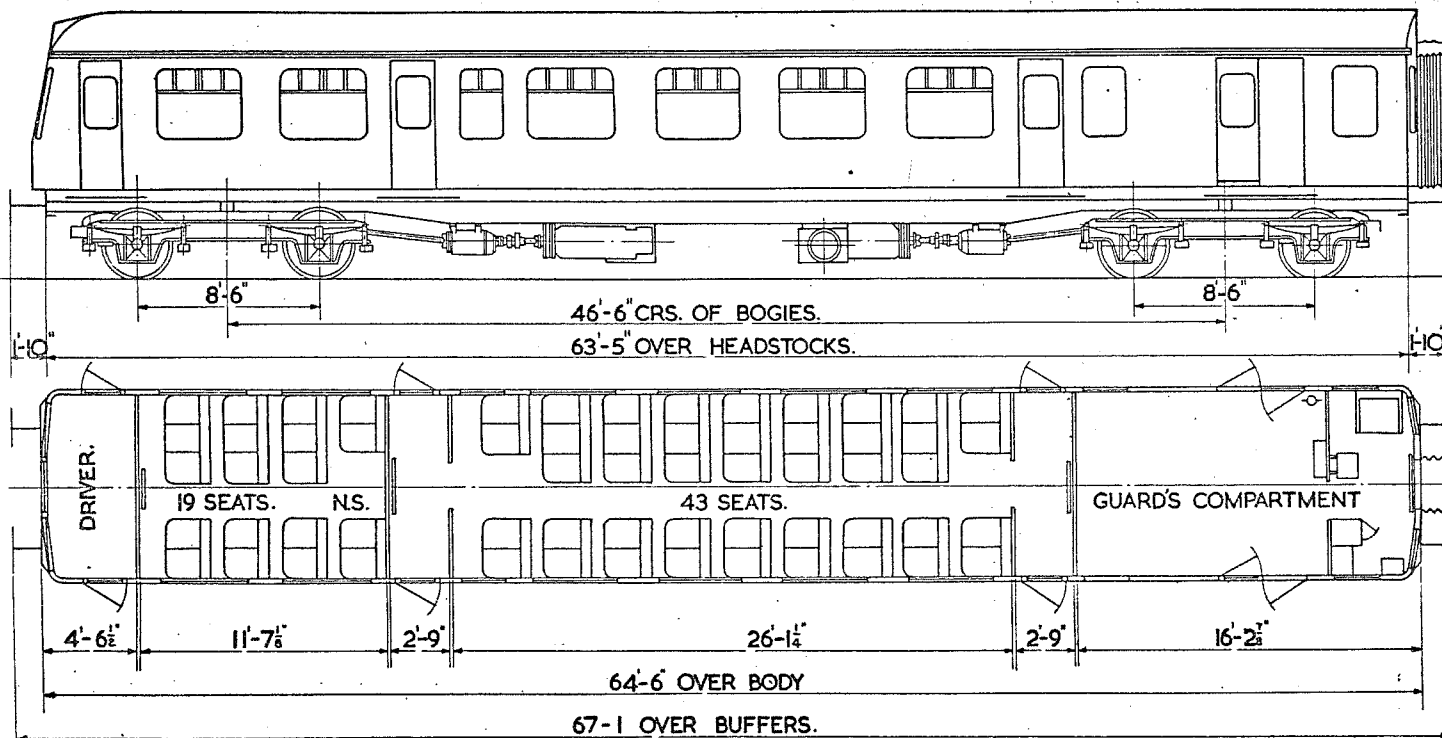

NS. - NON SMOKING.

2 SECONDS 62 SEATS.

1 GUARD & LUGGAGE COMPT.

1 DRIVING COMPT.

2 X 230 H.P. B.U.T. ENGINES.

QTY.	LOT.	VEHICLE Nos.
48	3020	E 50001 - E 50048.
1	30459	E 50049.

BUILT AT.	TARE.
DERBY	37 1/2 T
DERBY	37 1/2 T

GANGWAYED TRAILER OPEN LAVATORY SECOND

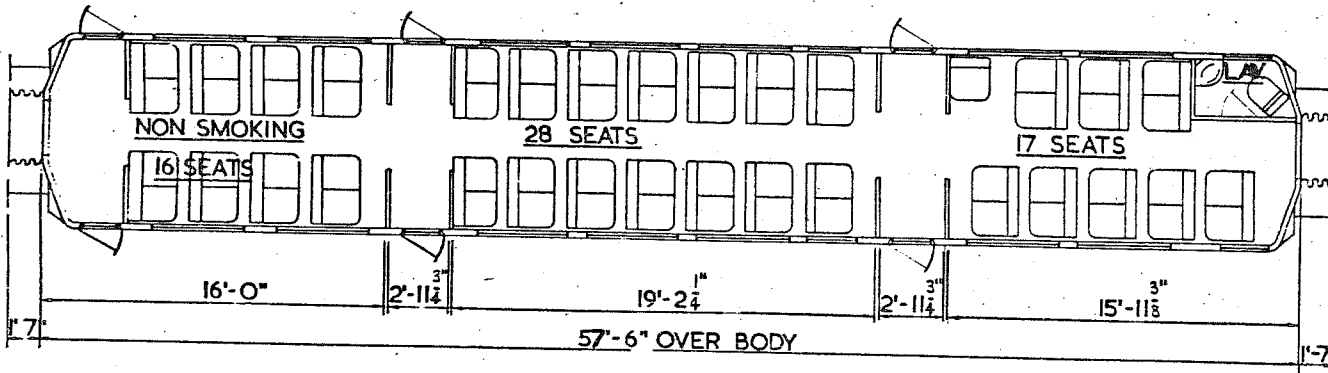
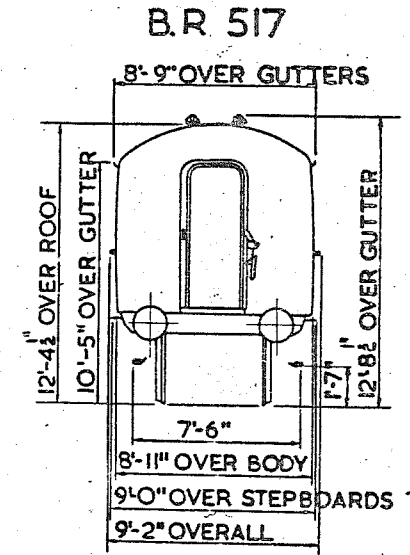
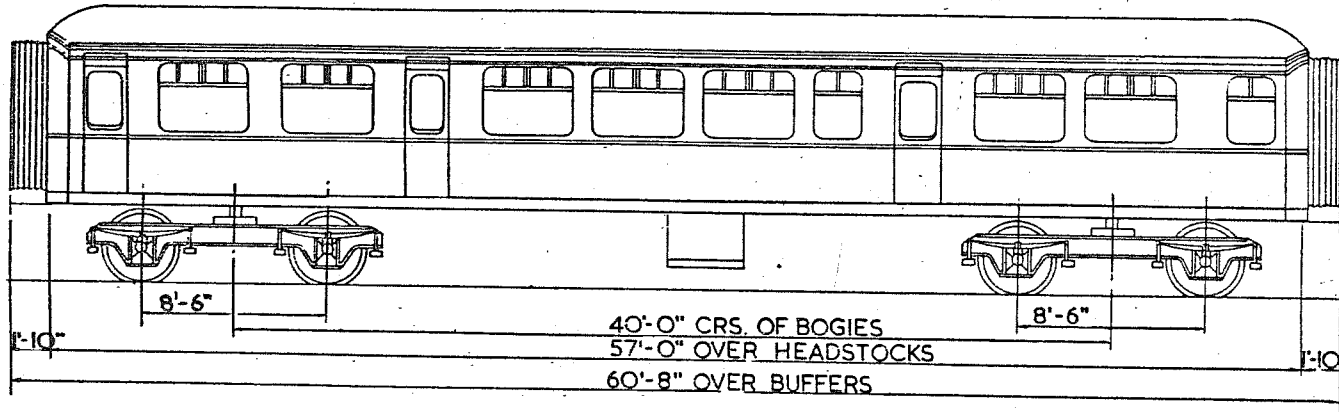

3 SECONDS- 61 SEATS
1 LAVATORY

QT LOT. VEHICLE NoS. BUILT AT TARE
 5. 30195. E79400-E79404. DERBY 21T

GANGWAYED MOTOR OPEN SECOND

B. R. 518

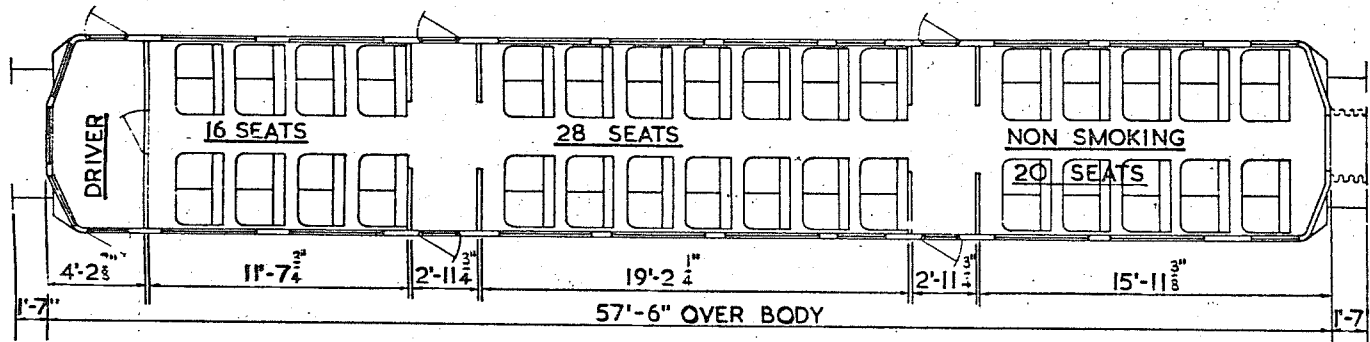
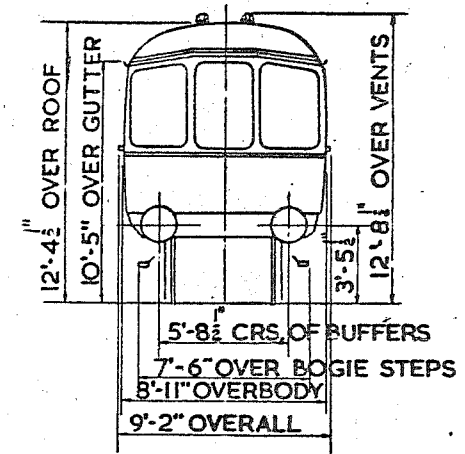
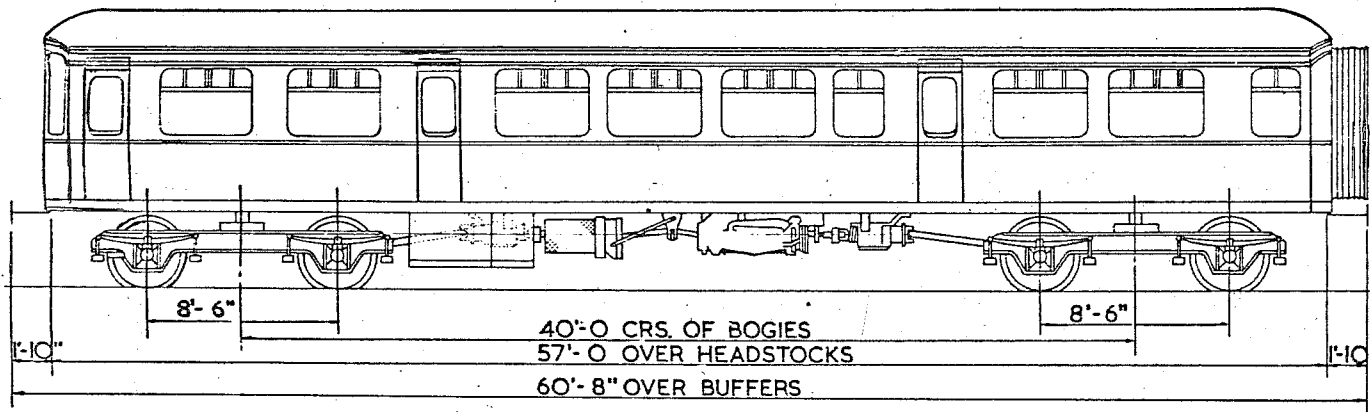

3 SECONDS- 64 SEATS
1 DRIVING COMPARTMENT

2 X 150 H.P. A.E.C. ENGINES

<u>QTY.</u>	<u>LOT</u>	<u>VEHICLE NoS.</u>	<u>BUILT AT</u>	<u>TARE</u>
5	30193.	E 79150-E 79154.	DERBY.	27T.

GANGWAYED MOTOR OPEN SECOND BRAKE

B.R. 520.

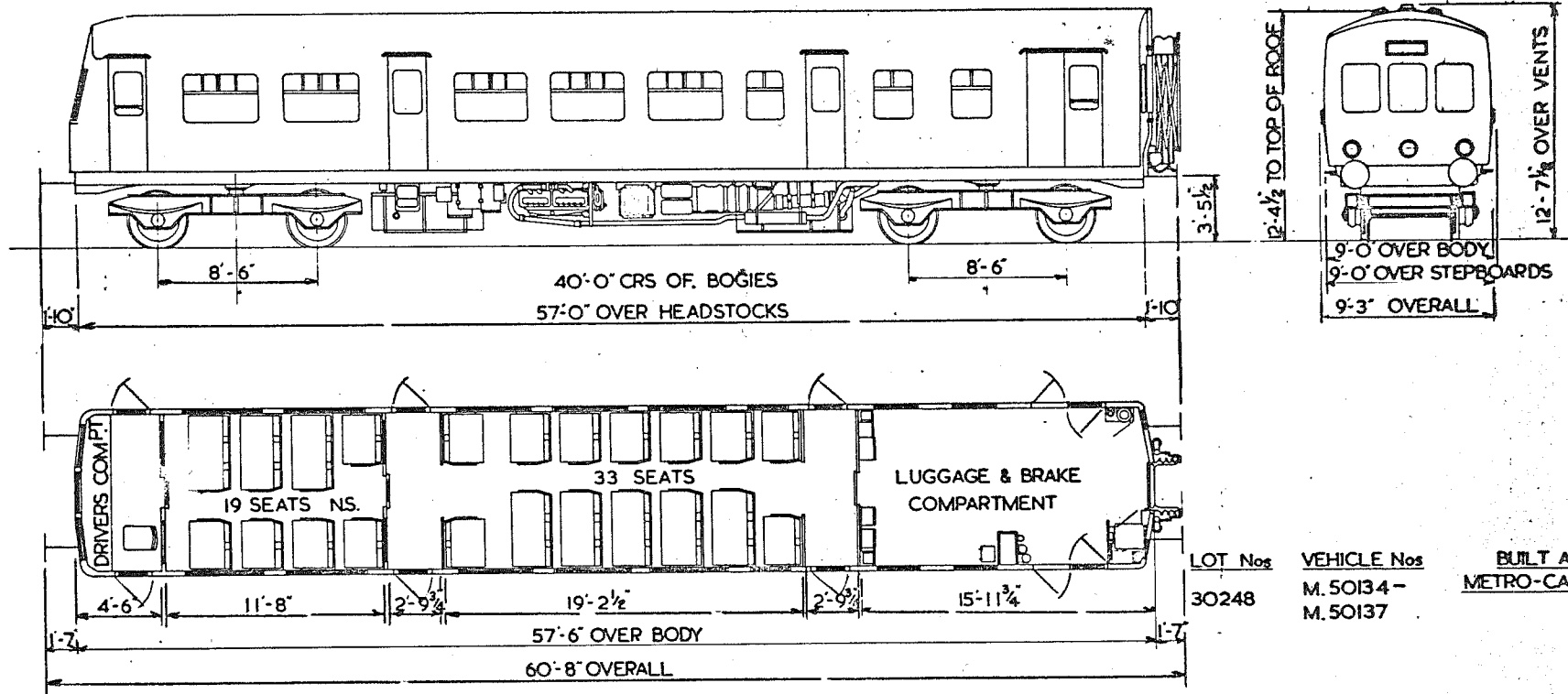

LOT Nos	VEHICLE Nos	BUILT AT	TARE
30248	M.50134 - M.50137	METRO-CAMMELL	33 T

- 2 - SECOND 52 SEATS
- 1 - DRIVERS COMPARTMENT
- 1 - LUGGAGE COMPARTMENT

NS NON SMOKING

2 x 18 H.P. R.R. ENGINES.

GANGWAYED MOTOR OPEN SECOND BRAKE

BR. 521.

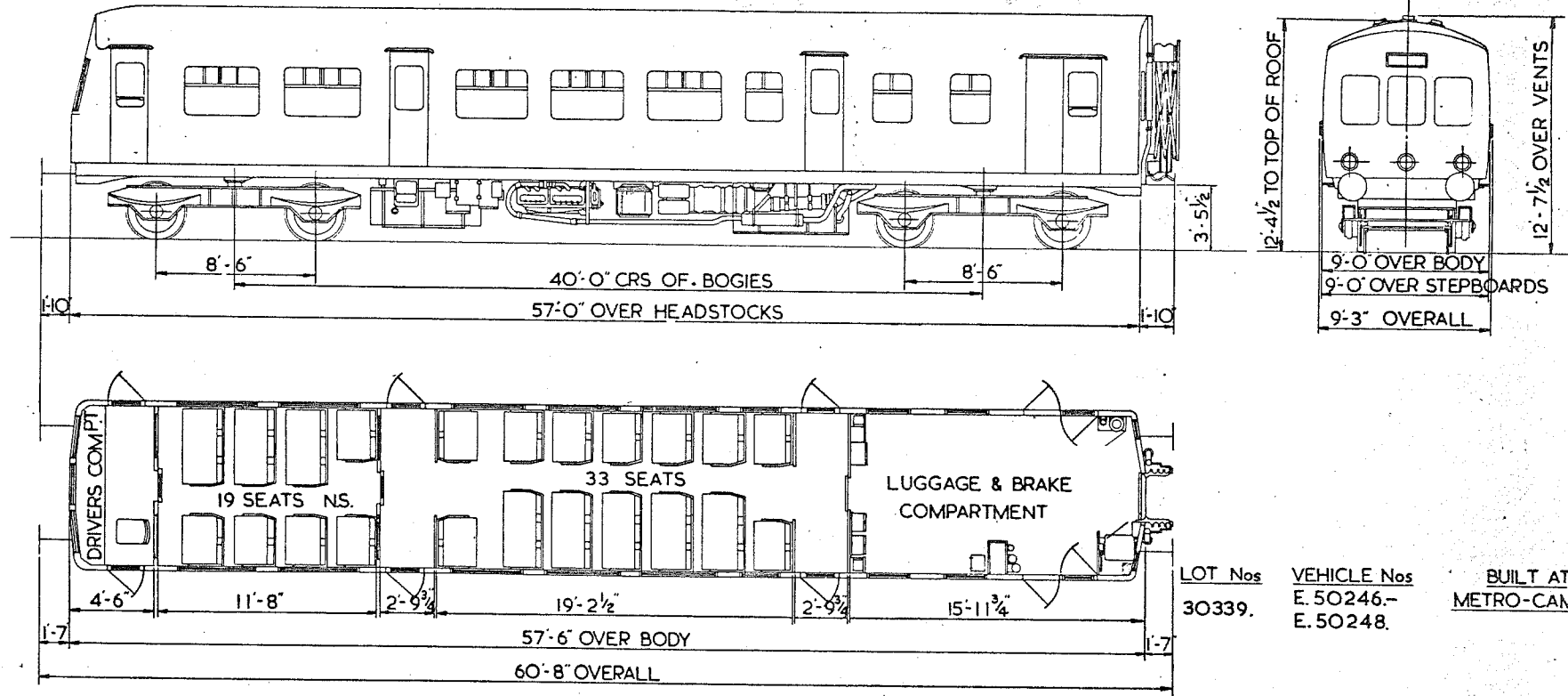

LOT Nos	VEHICLE Nos	BUILT AT	TARE
30339.	E. 50246.- E. 50248.	METRO-CAMMELL	32 T

- 2 - SECOND 52 SEATS
- 1 - DRIVERS COMPARTMENT
- 1 - LUGGAGE COMPARTMENT

NS NON SMOKING

2 x 15 C H.P. B.U.T. ENGINES

GANGWAYED MOTOR OPEN SECOND BRAKE

B.R. 522.

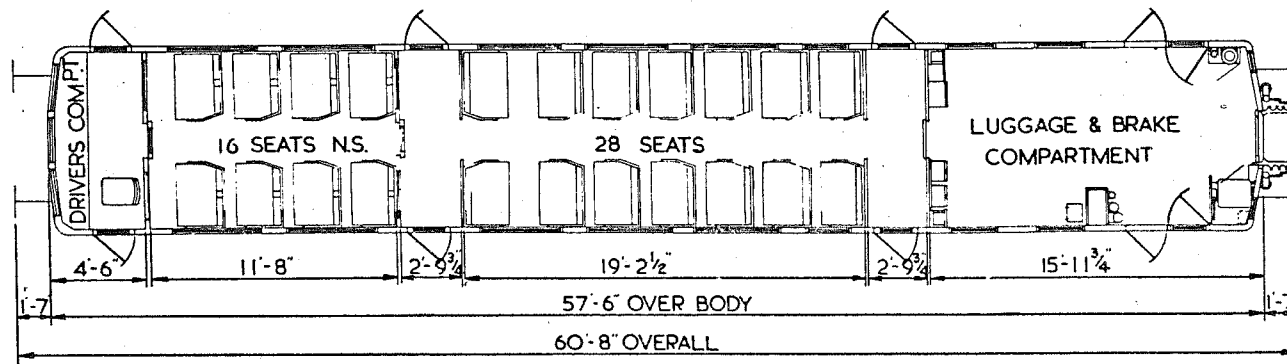
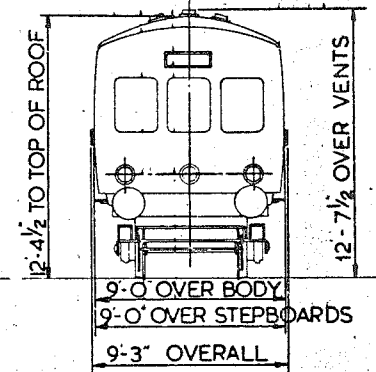
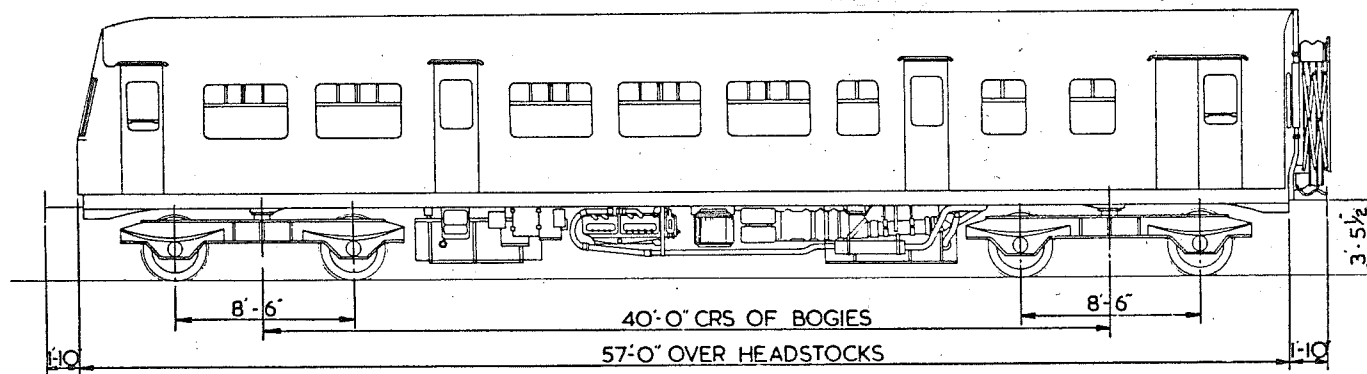

LOT Nos	VEHICLE Nos	BUILT AT	TARE
30252	E50152-E50157	METRO-CAMMELL	32 T
30254	E50164 E50167		

- 2 - SECOND 44 SEATS
- 1 - DRIVERS COMPARTMENT
- 1 - LUGGAGE COMPARTMENT

NS NON SMOKING

2 x 150 H.P. BUT. ENGINES

GANGWAYED MOTOR OPEN SECOND BRAKE

B.R. 523.

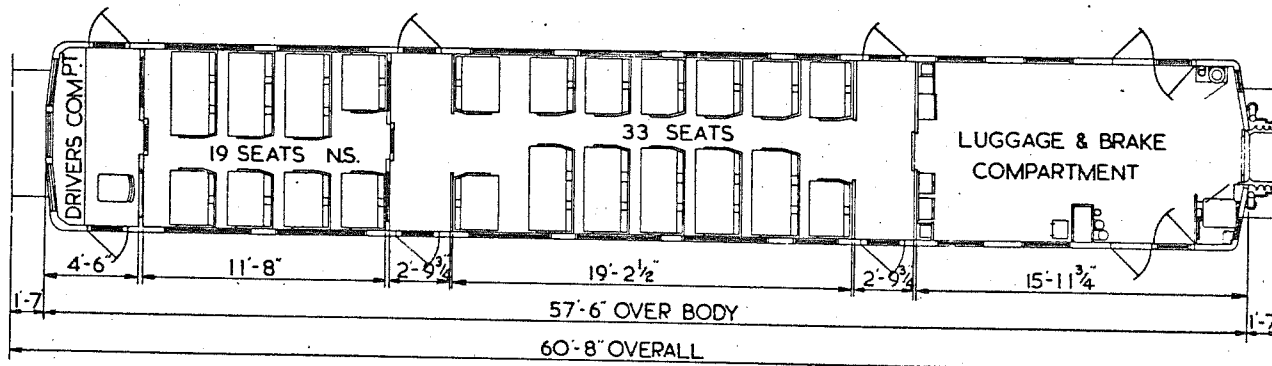
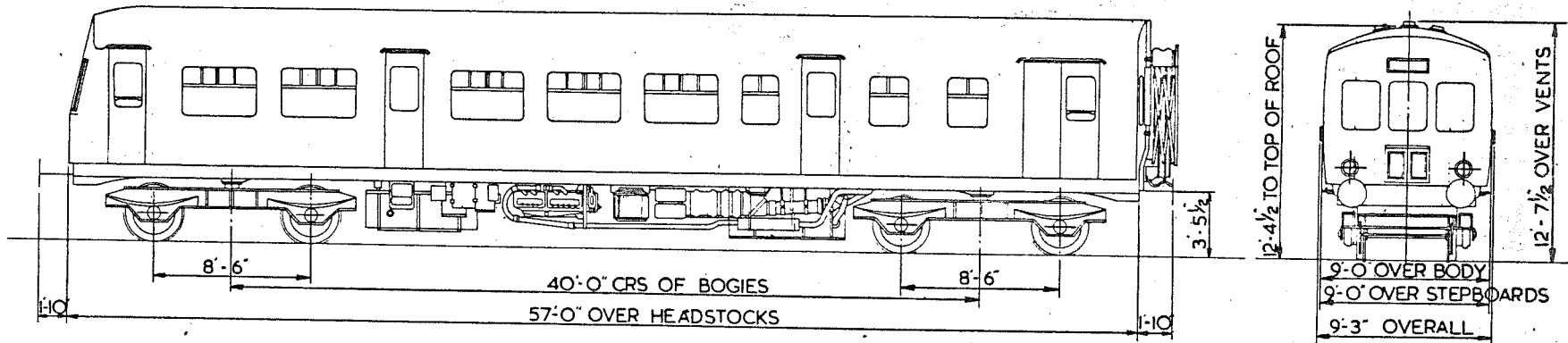

LOT Nos	VEHICLE Nos	BUILT AT	TARE
30259	E5C198-E5O209	METRO-CAMMELL	32 T.
30261	E5O210-E5O233		
30266	E5O250-E5O259		
30270	E5O290-E5O296		
30275	M5O303-M5O320		
30467	M5I174 - M5I203		
	E5I204 - E5I223		
	SC5I224 - SC5I253		
30500	E5I425 - E5I444		
	SC5I445 - SC5I470		
30587	SC5I795 SC5I80I		

- 2 - SECOND 52 SEATS
- 1 - DRIVERS COMPARTMENT
- 1 - LUGGAGE COMPARTMENT

NS NON SMOKING

2 x 150 H.P. B.U.T. ENGINES

GANGWAYED MOTOR OPEN SECOND BRAKE

BR. 524.

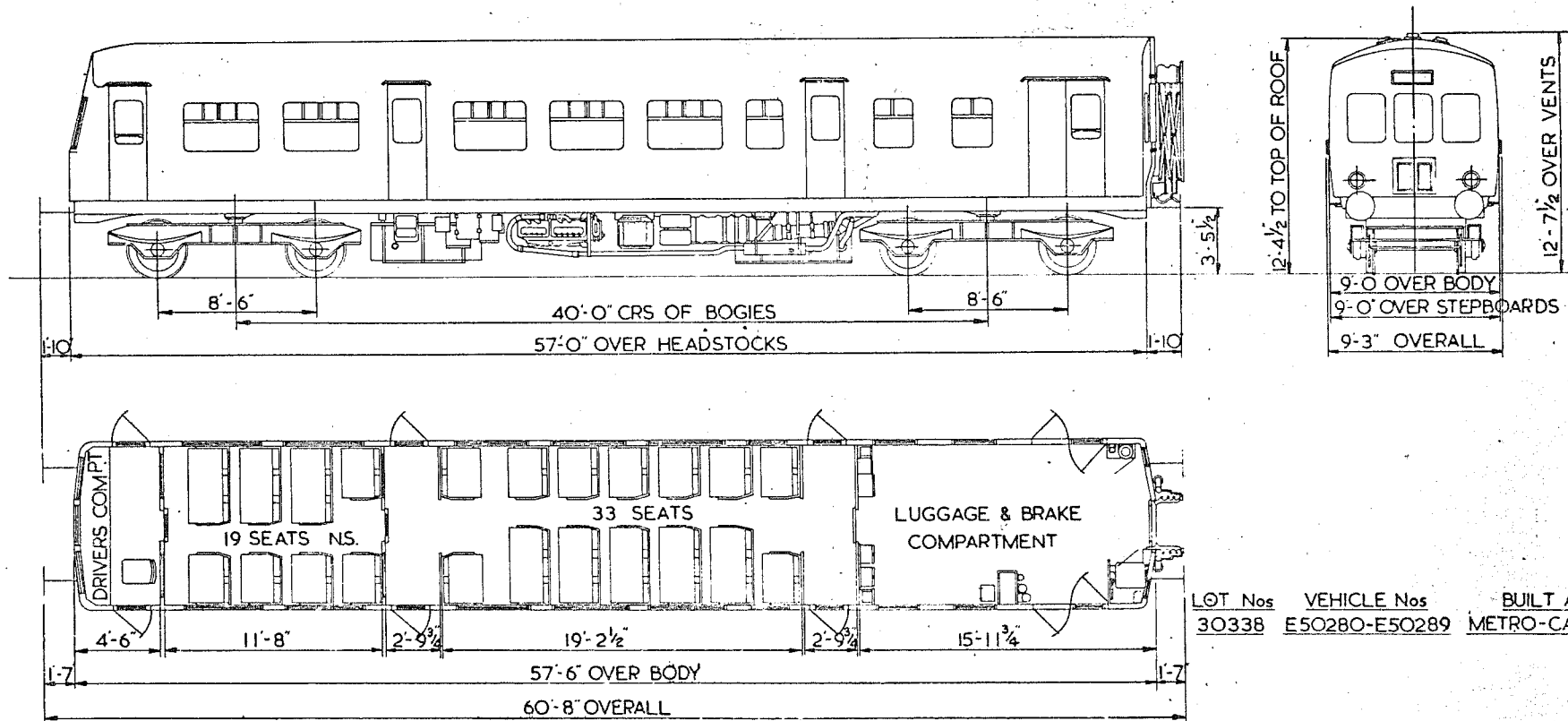

LOT Nos	VEHICLE Nos	BUILT AT	TARE
30338	E50280-E50289	METRO-CAMMELL	33 T

- 2 - SECOND 52 SEATS
- 1 - DRIVERS COMPARTMENT
- 1 - LUGGAGE COMPARTMENT

NS NON SMOKING

2 x 18C H.P. R.R. ENGINES

GANGWAYED MOTOR OPEN SECOND BRAKE

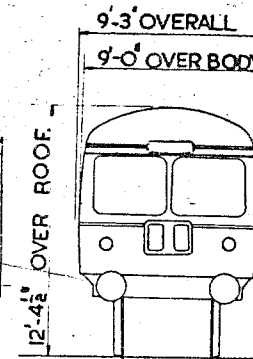
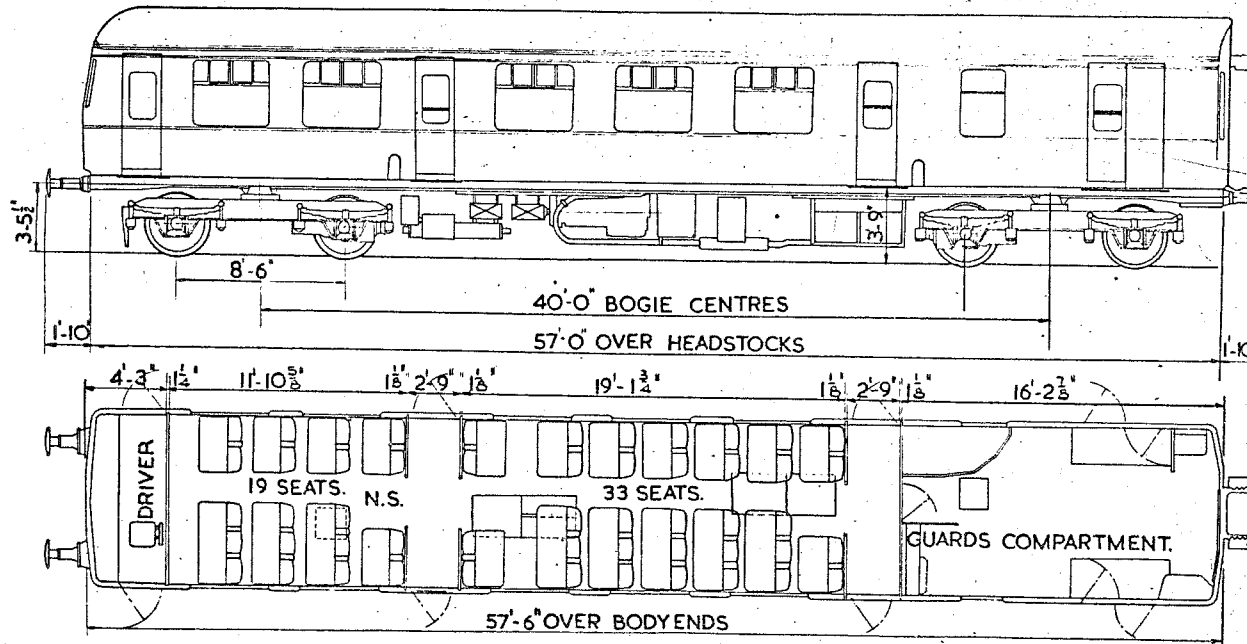

END VIEW FOR
Nos. E50370-E50374
& Nos. M50390-M50394

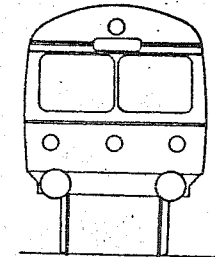

END VIEW FOR
REMAINING CAR Nos.
ON THIS DRAWING.

- 2 SECOND. 52 SEATS.
- 1 DRIVING COMPARTMENT.
- 1 GUARDS COMPARTMENT.

2 X 150 H.P. B.U.T. ENGINES.

<u>LOT No.</u>	<u>VEHICLE Nos.</u>
30280	E 50359 - E 50372
30282	E 50373 - E 50389
30284	M 50390 - M50394

BUILT AT
 CRAVENS

TARE
 29 T

N.S. - NON SMOKING.

B.R. 526.

GANGWAYED DRIVING TRAILER OPEN COMPOSITE LAVATORY.

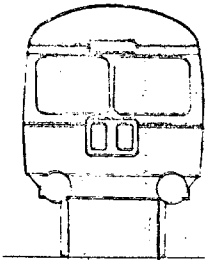

END VIEW FOR
E56125 - E56129
M56145 - M56149

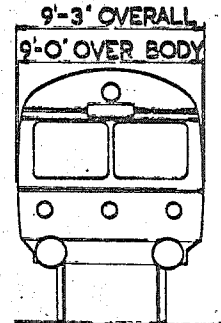
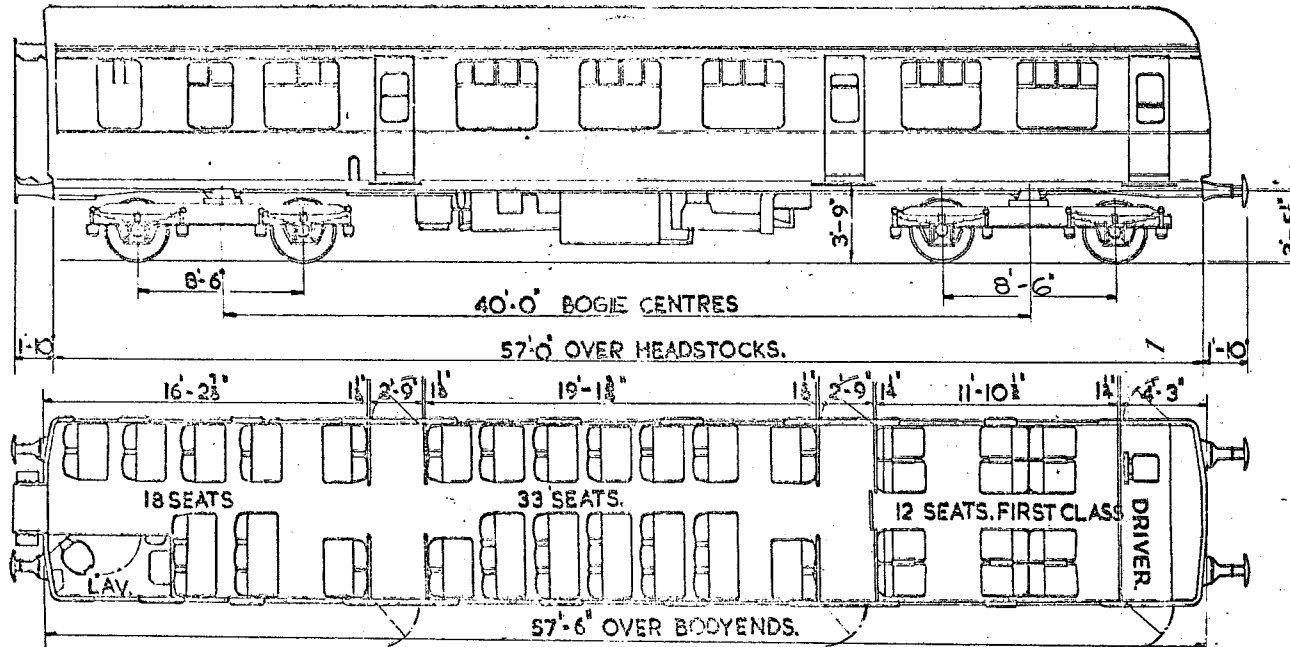

END VIEW FOR
REMAINING CAR No. 6.
ON THIS DRAWING.

- 1 FIRST. 12 SEATS.
- 2 SECOND. 51 SEATS.
- 1 DRIVING COMPARTMENT.
- 1 LAVATORY.

LOT No.	VEHICLE Nos.
30281	E 56114-E56127
30083	E 56128-E56144
30085	M56145-M56149

BUILT AT	TARE.
CRAVENS	23 T
.	.
.	.

GANGWAYED MOTOR SECOND BRAKE

BR. 527

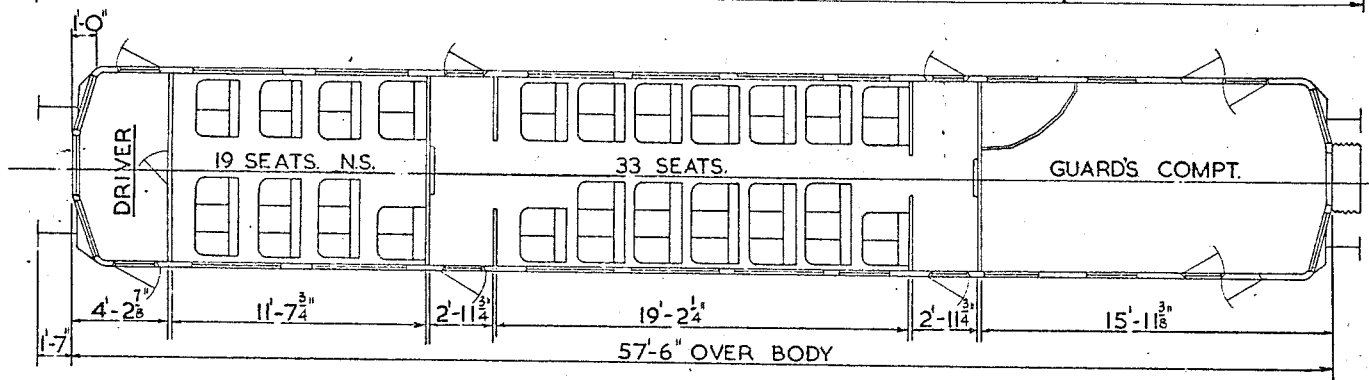
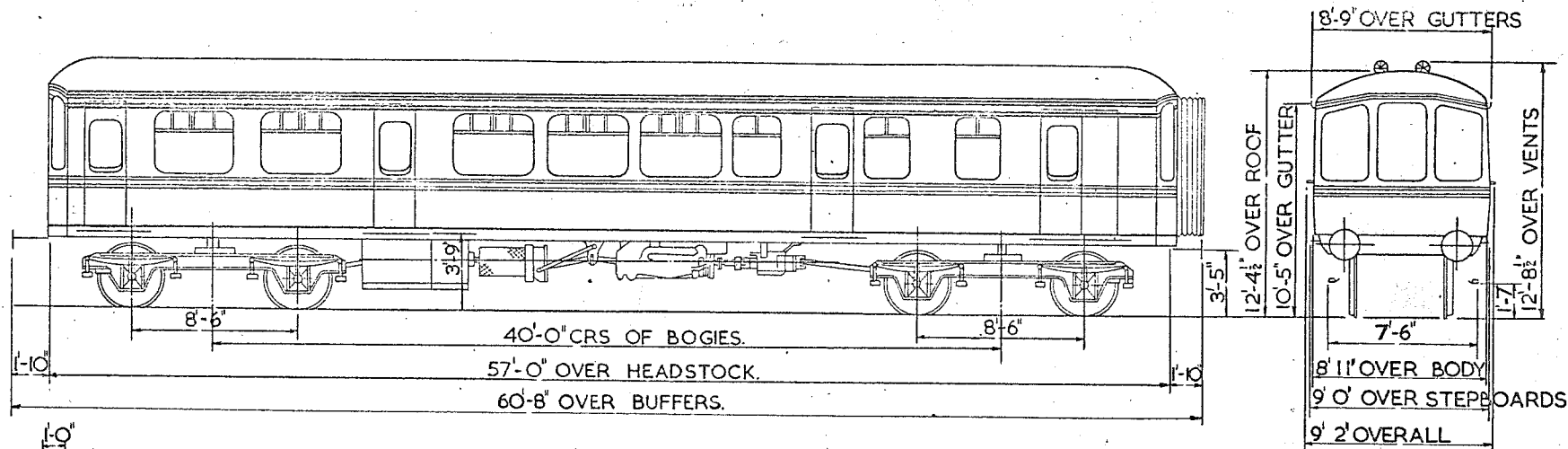

N.S. NON SMOKING.

QTY. LOT. VEHICLE No. BUILT. TARE.
 4 30240 E. 79137-E. 79140 DERBY 27T.

- 1 DRIVING COMPARTMENT. 2 x 150 H.P. A.E.C. ENGINES.
- 1 GUARD & LUGGAGE COMPT.
- 2 COMPARTMENTS. 2ND CLASS. 52 SEATS.

GANGWAYED MOTOR OPEN SECOND BRAKE

B.R. 528

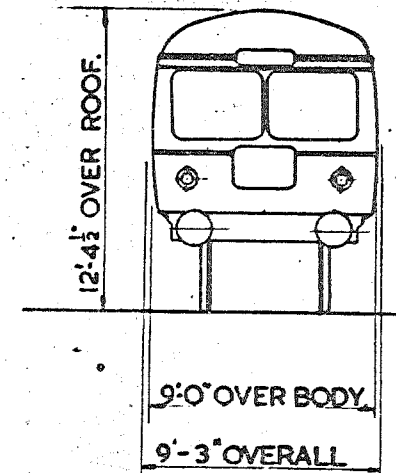
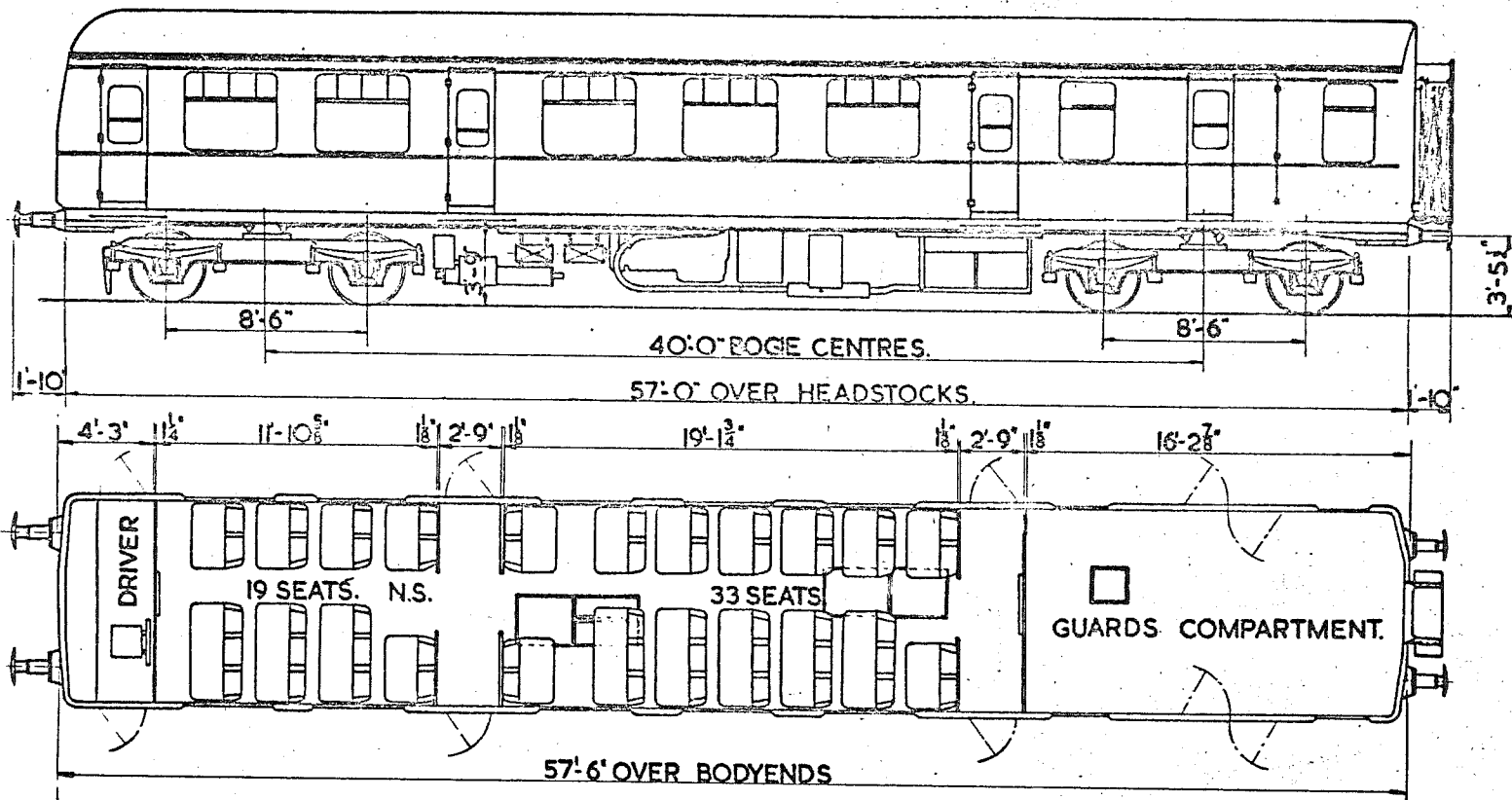

2 SECOND. 52 SEATS.
 1 DRIVING COMPARTMENT.
 1 GUARDS COMPARTMENT.

N.S. -NON SMOKING. 2x 150 H.P. B.U.T. ENGINES.

<u>LOT. No.</u>	<u>VEHICLE Nos.</u>	<u>BUILT AT.</u>	<u>TARE.</u>
30352	M50752-M50784	CRAVENS	30 T

GANGWAYED MOTOR OPEN COMPOSITE LAVATORY.

BR.529.

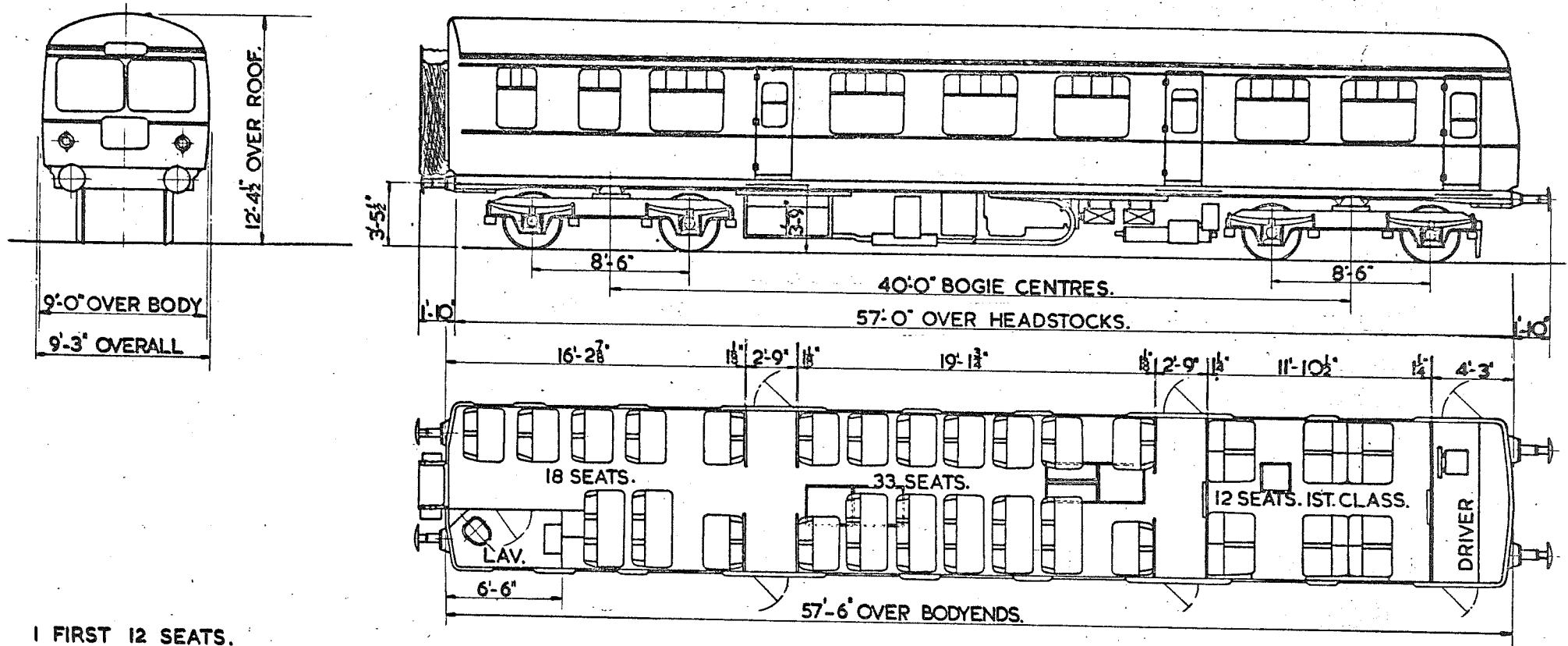

- 1 FIRST 12 SEATS.
- 2 SECOND. 51 SEATS
- 1 DRIVING COMPARTMENT.
- 1 LAVATORY.

2 X 150 H.P. B.U.T. ENGINES.

LOT No	VEHICLE Nos	BUILT AT	TARE
30353	M 507L - M 508I7	CRAVENS	30 T

GANGWAYED TRAILER OPEN COMPOSITE LAVATORY

B.R. 530

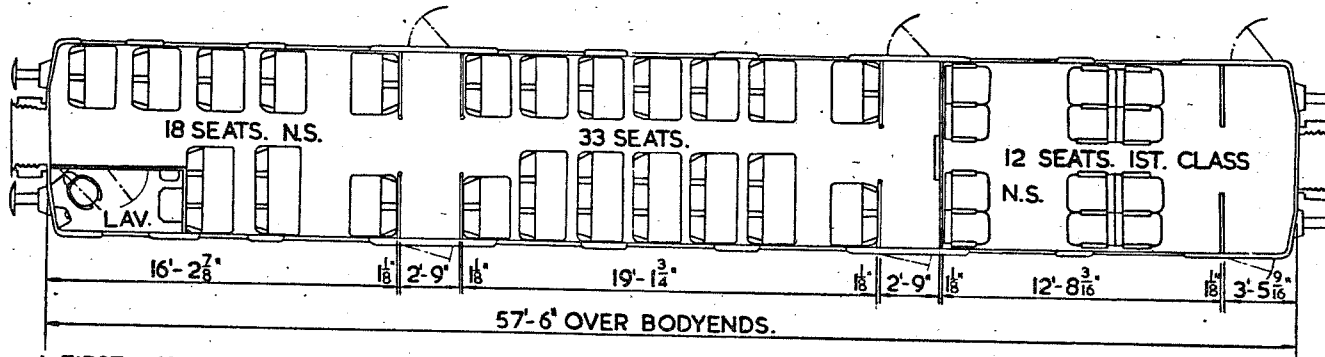
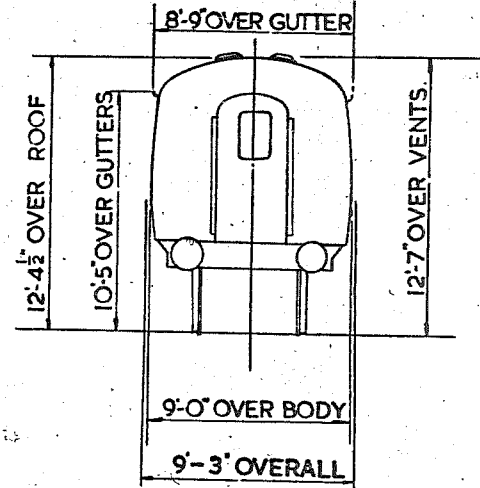
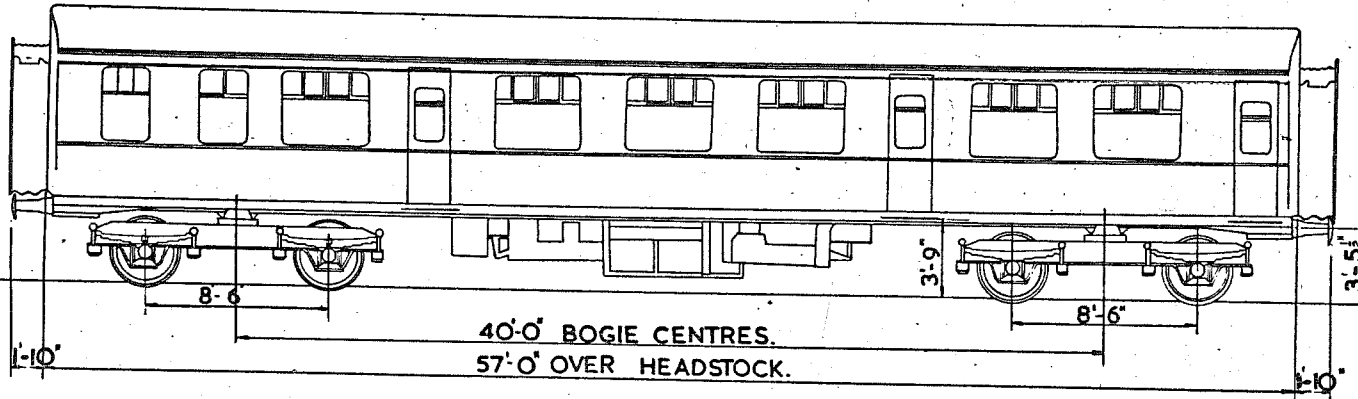

- 1 FIRST 12 SEATS
- 2 SECOND 51 SEATS
- 1 LAVATORY

LOT No
30354

VEHICLE Nos
M 59307 - M 59325

BUILT AT
CRAVENS

TARE
23 T

N S - NON SMOKING

NON GANGWAYED MOTOR PARCEL VAN

BR. 531.

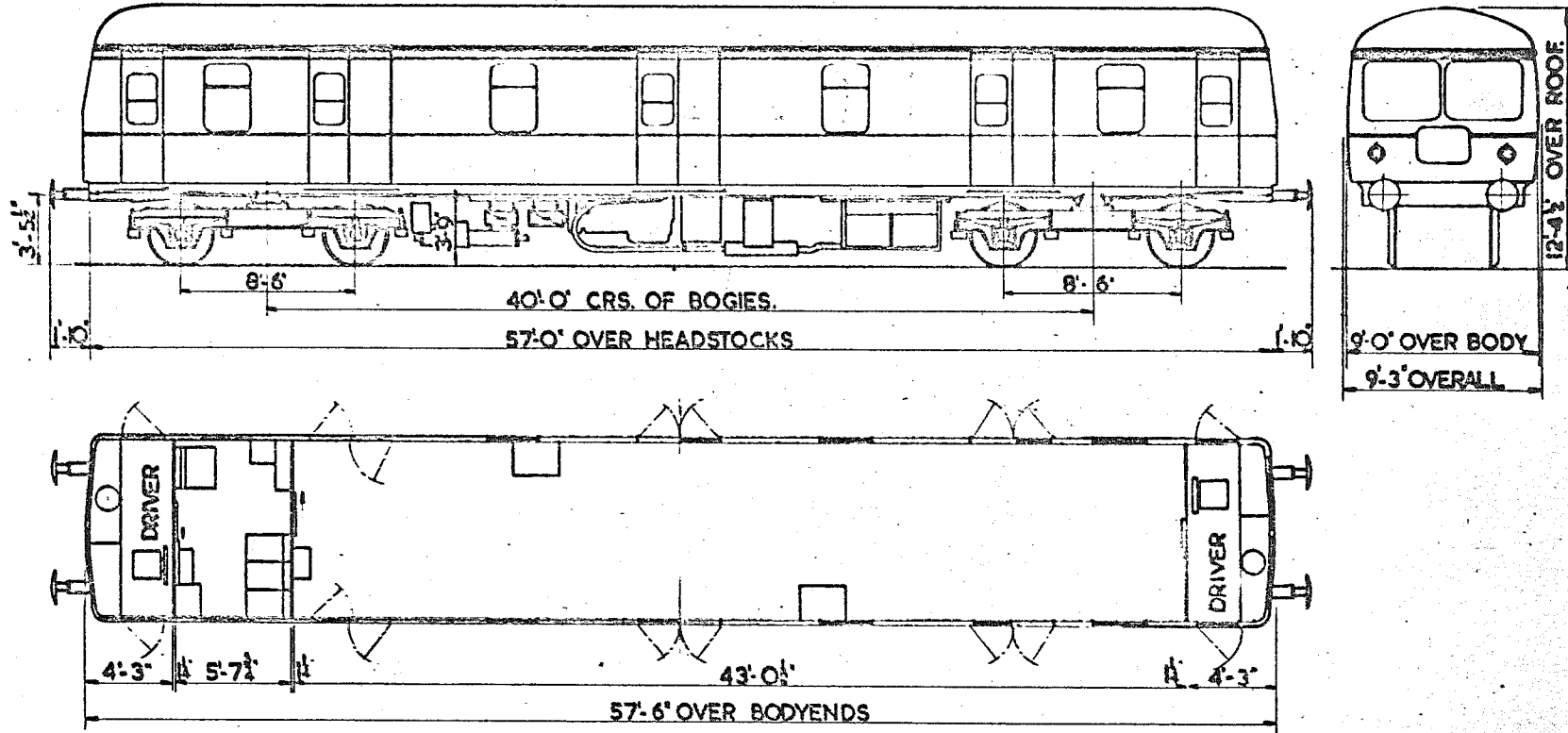

- 2 DRIVING COMPARTMENTS.
- 1 GUARDS COMPARTMENT.
- 1 LUGGAGE COMPARTMENT.
- 2x150 H.P. B.U.T. ENGINES.

LOT No.	VEHICLE Nos.	BUILT AT	TARE
30418	M55997-M55999	CRAVENS	30 T.

GANGWAYED MOTOR OPEN SECOND BRAKE.

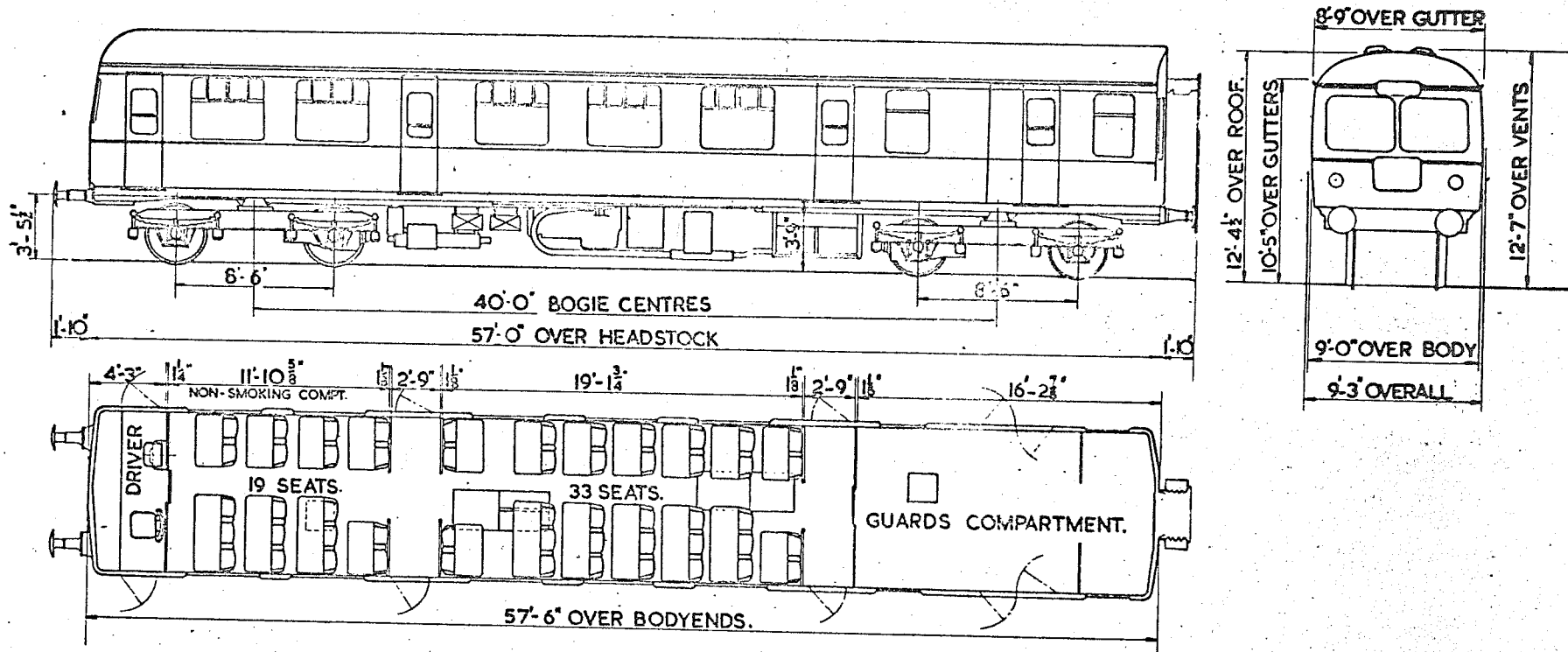

- 2 SECOND. 52 SEATS.
- 1 DRIVING COMPARTMENT.
- 1 GUARDS COMPARTMENT.
- 2 x 150 H.P. B.U.T. ENGINES.

LOT No.	VEHICLE Nos.	BUILT AT	TARE
20469	E51254-E 51301.	CRAVENS.	30T.

GANGWAYED DRIVING TRAILER OPEN COMPOSITE LAVATORY.

B.R. 533

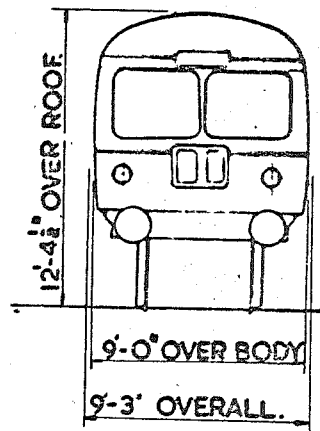
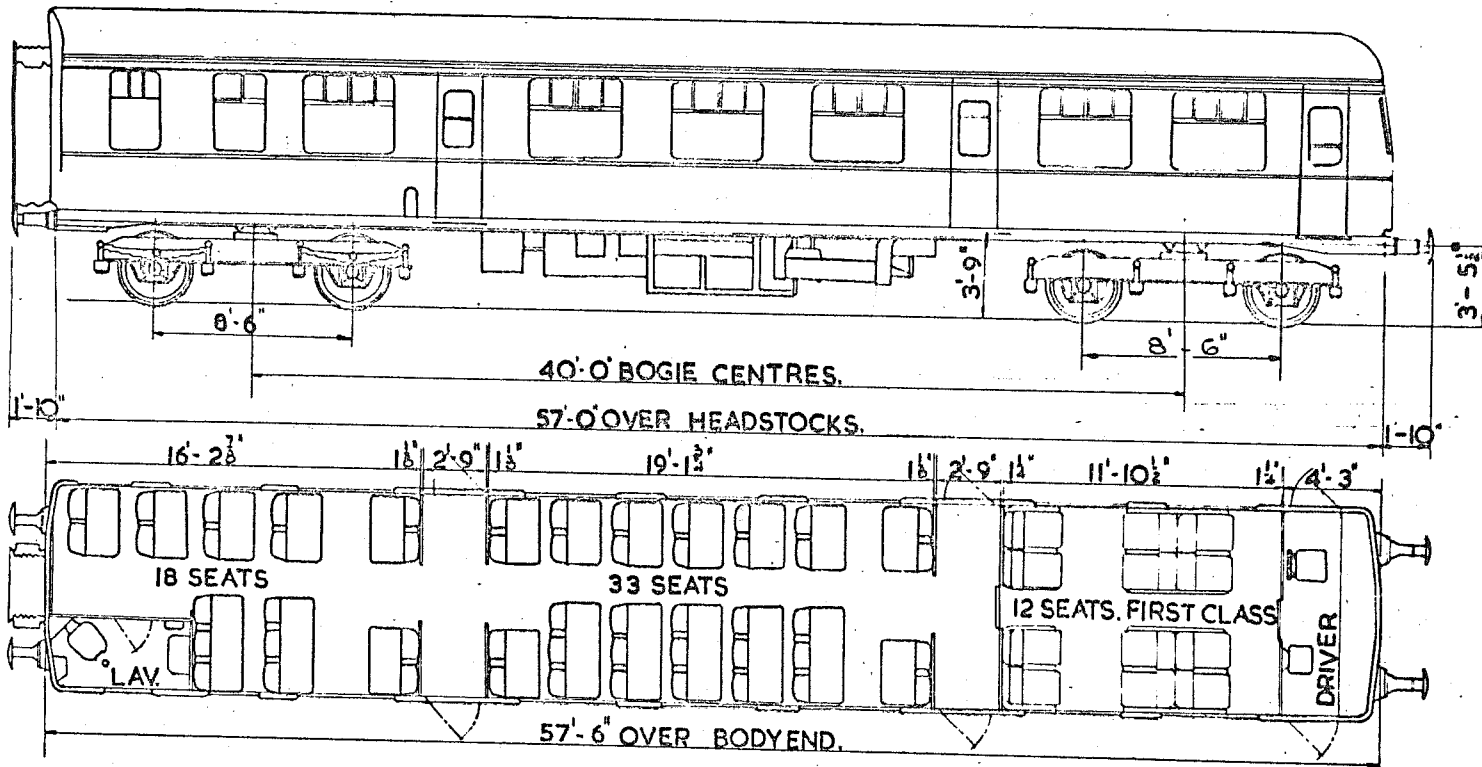

- 1 FIRST 12 SEATS.
- 2 SECOND 51 SEATS.
- 1 DRIVING COMPARTMENT.
- 1 LAVATORY.

<u>LOT No.</u>	<u>VEHICLE No.</u>	<u>BUILT AT</u>	<u>TARE</u>
30470	E56412-E56459	CRAVENS	24 T

NON-GANGWAYED MOTOR OPEN SECOND BRAKE.

B.R. 534

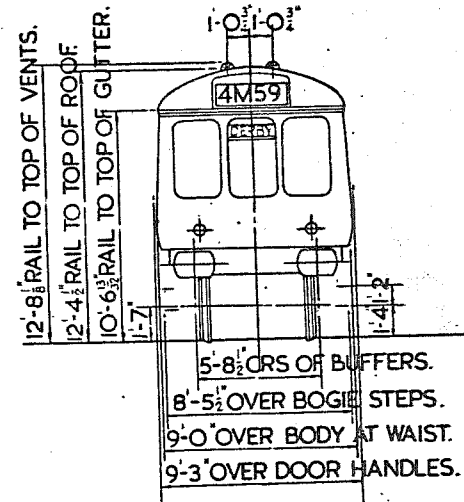
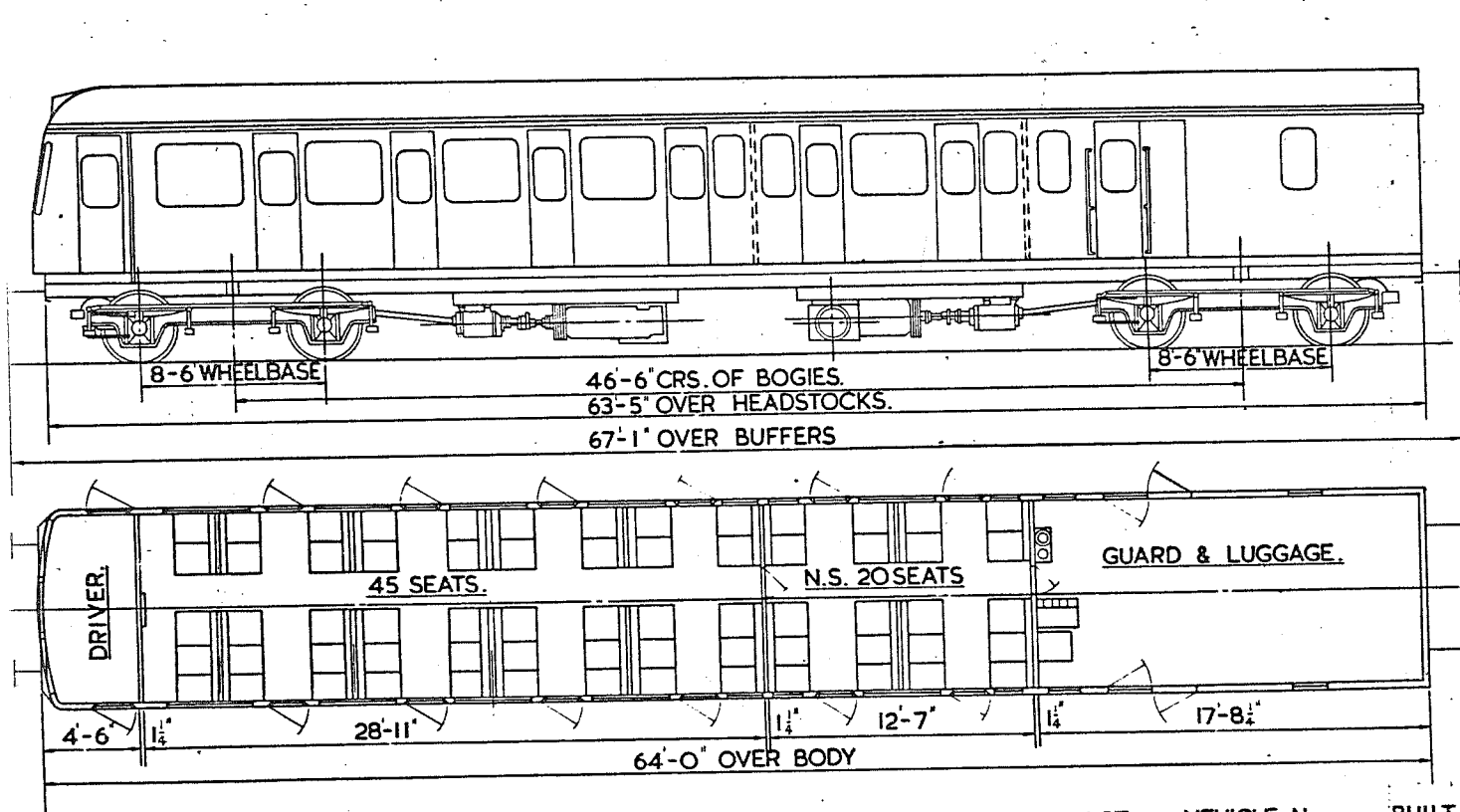

N.S.- NON SMOKING.

NOTE: ELECTRIC TAIL LAMPS NOT FITTED TO THE FOLLOWING VEHICLES:-
W.51320-W.51305 INCLUSIVE, AND
W.51332-W.51370 INCLUSIVE.

- 2 SECOND - 65 SEATS.
- 1 DRIVING COMPARTMENT.
- 1 GUARD & LUGGAGE.

2 X 150 H.P. B.U.T. ENGINES.

QTY.	LOT.	VEHICLE No.	BUILT AT	TARE.
15	30543	W51302-W51316	B ^o HAM RLY. C.&W. Co.	36 T
42	30546	W51332-W51373	PRESSED STEEL	36 T

NON-GANGWAYED MOTOR OPEN SECOND.

B.R. 535

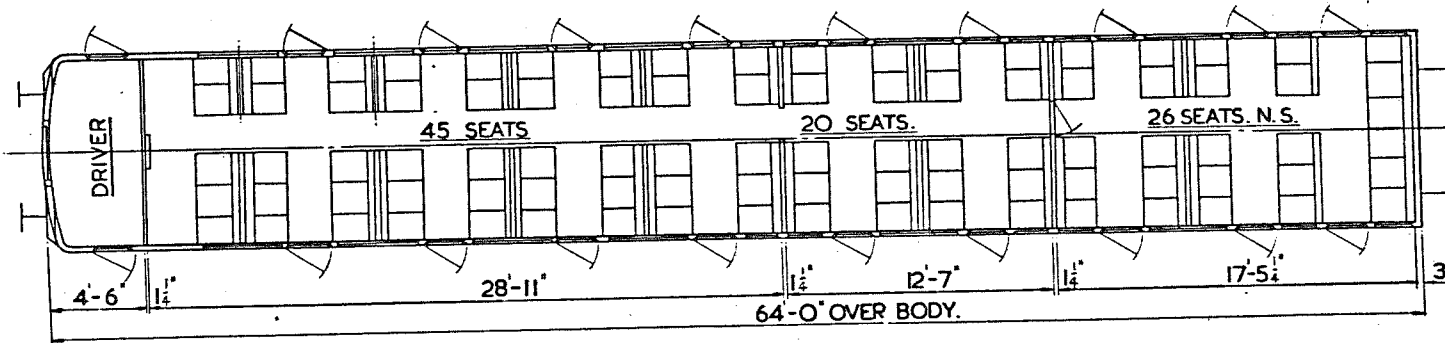
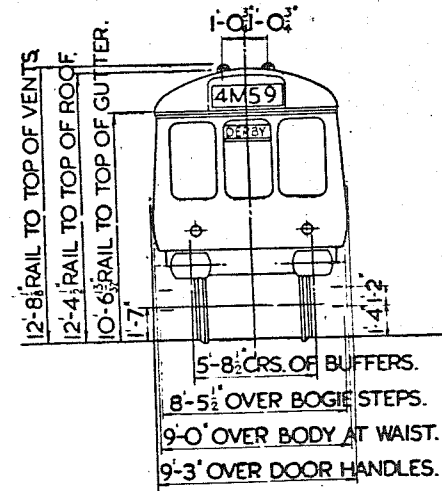
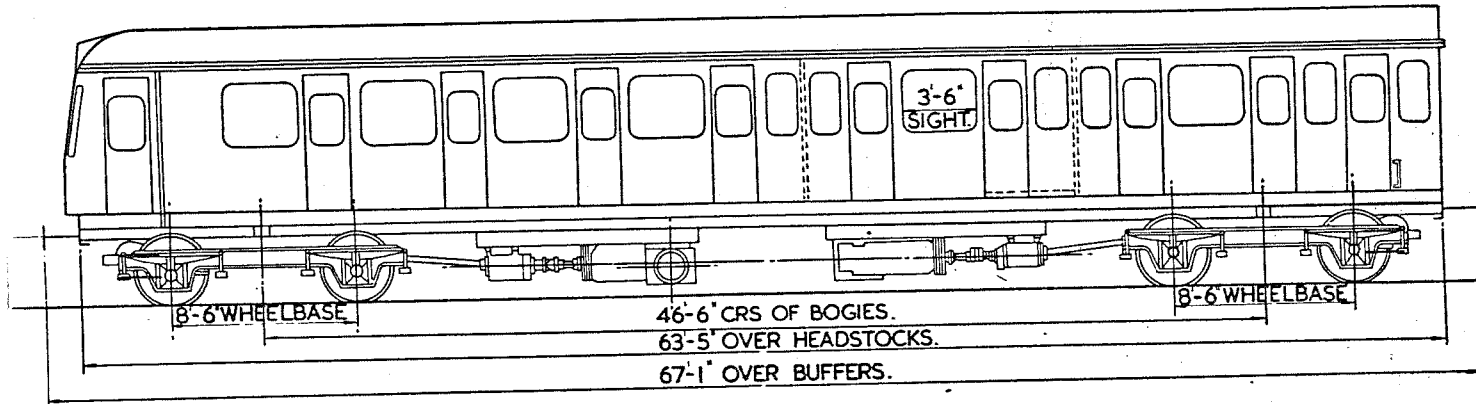

N.S.- NON SMOKING.

NOTE: ELECTRIC TAIL LAMPS NOT FITTED TO THE FOLLOWING VEHICLES:-
W.51317-W51320 INCLUSIVE, AND
W.51374-W51412 INCLUSIVE.

3 SECOND - 91 SEATS
1 DRIVING COMPARTMENT.

2 X 150 H.P. B.U.T. ENGINES.

QTY.	LOT	VEHICLE No	BUILT AT	TARE.
15	30545	W51317-W51331	B'HAM RLY. V. Co.	36 T.
42	30548	W51374-W51415	PRESTED STEEL.	36 T.

GANGWAYED MOTOR OPEN SECOND BRAKE.

B.R. 536

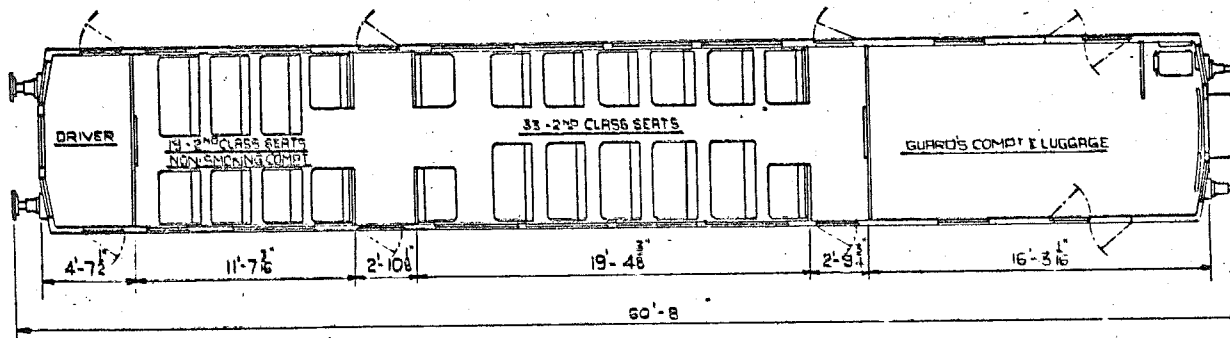
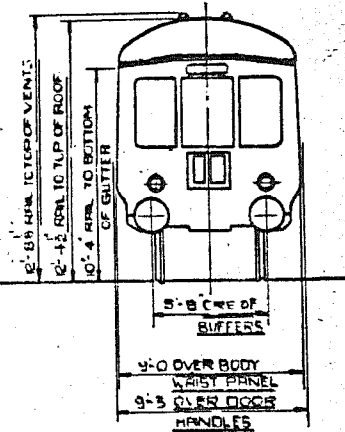
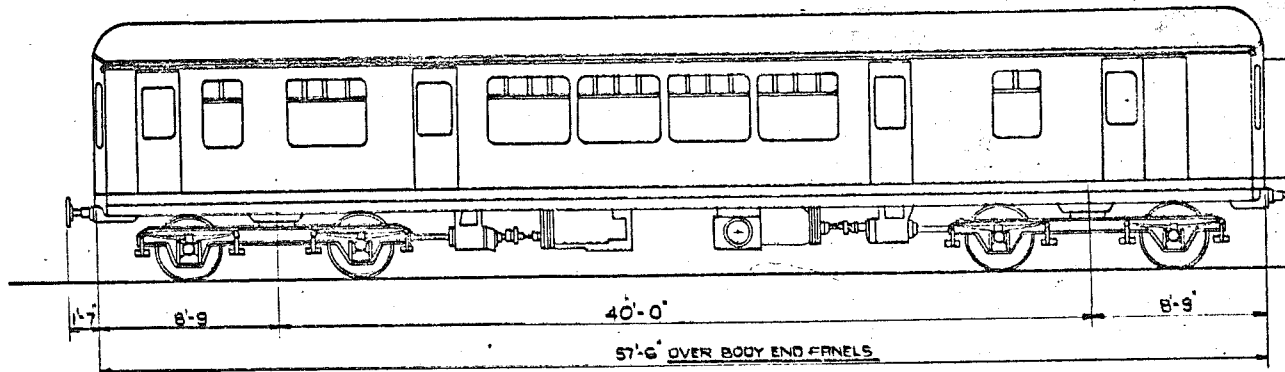

LOT Nos	VEHICLE Nos	BUILT AT	TARE
30278	SC50339-SC50347	GLOUCESTER	30 T
30278	M 50348 -M 50358	"	"
30444	SC51108 -SC51127	"	"

2 SECOND 52 SEATS
 1 DRIVING COMPARTMENT.
 1 GUARDS COMPARTMENT.
 2 X 150 H.P. B.U.T. ENGINES.

GANGWAYED DRIVING TRAILER OPEN COMPOSITE LAVATORY.

B. R. 537

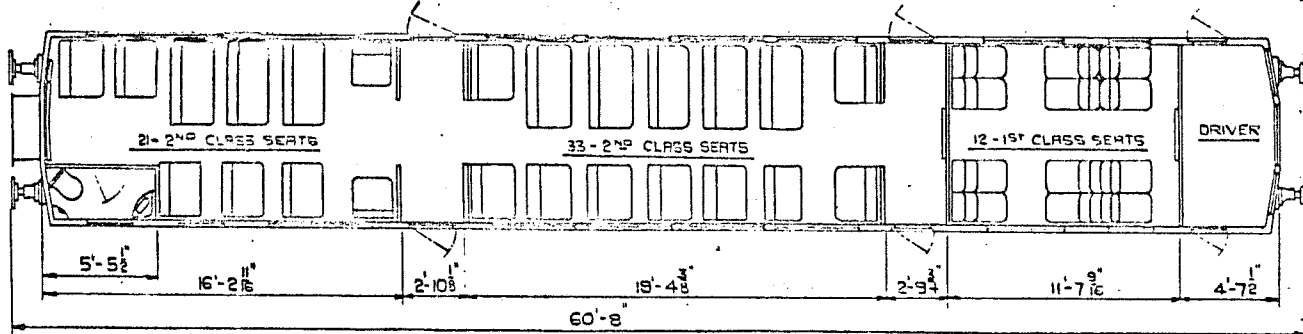
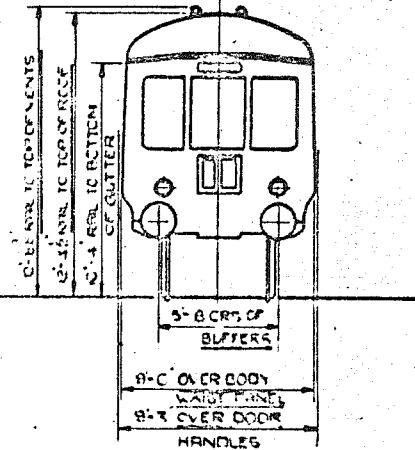
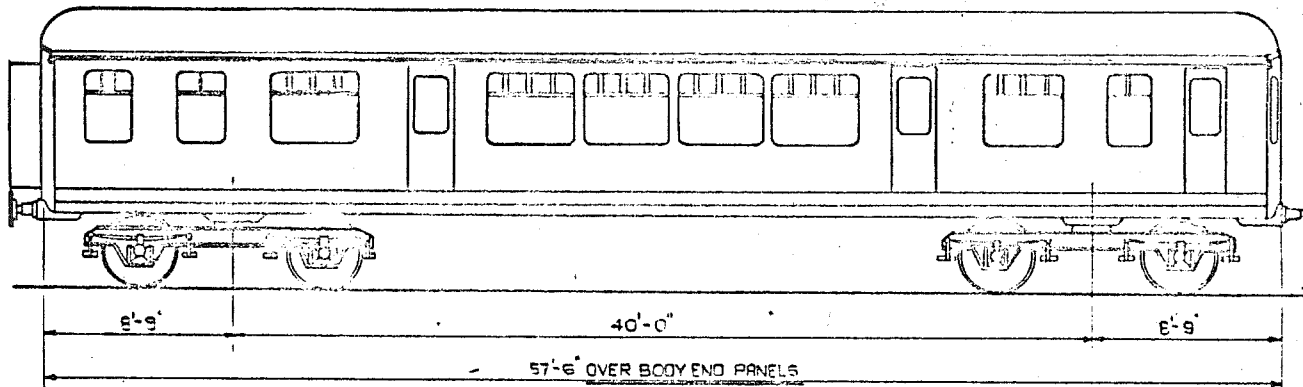

LOT Nos.	VEHICLE Nos.	BUILT AT	TARE
30279	SC 56094-SC56102.	GLOUCESTER.	25 T.
30279	M56103-M56113.		
30445	SC56300-SC56319.		

- 1 FIRST. 12 SEATS.
- 2 SECOND. 54 SEATS.
- 1 DRIVING COMPARTMENT.
- 1 LAVATORY

NON GANGWAYED DRIVING TRAILER OPEN SECOND

B. R. 538

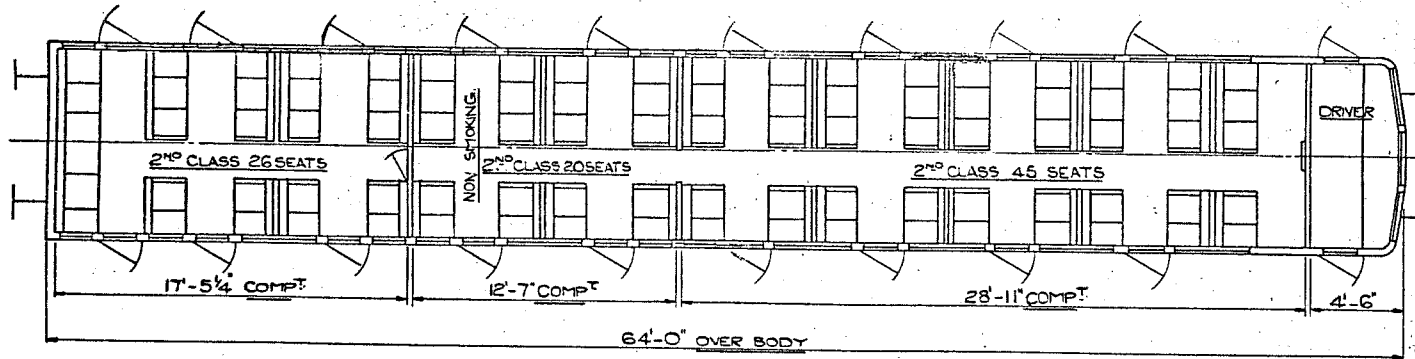
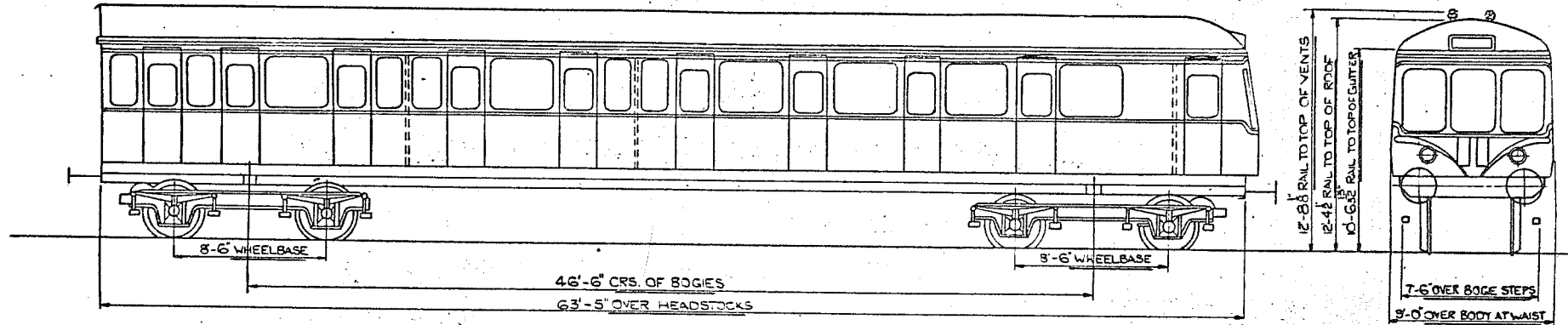

3 SECOND. 91 SEATS.
 1 DRIVING COMPARTMENT.

LOT No.	VEHICLE Nos.	BUILT AT	TARE
30420	W56291 - W56299	GLOUCESTER	27 T

NON GANGWAYED MOTOR OPEN SECOND BRAKE.

B. R. 539

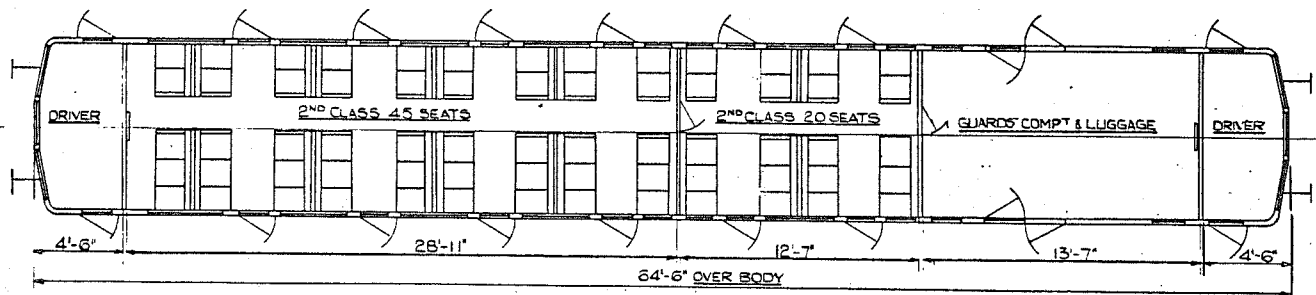
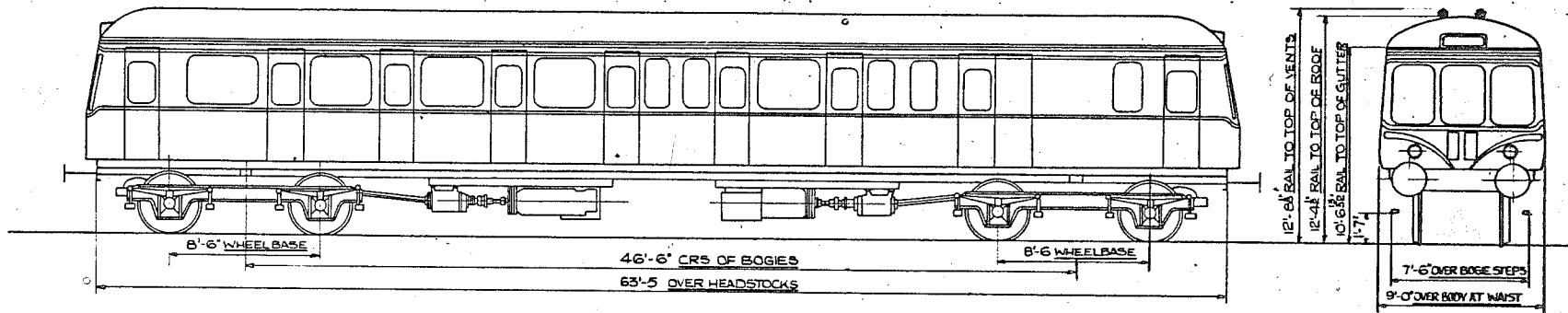

2 SECOND. 65 SEATS.
 2 DRIVING COMPARTMENTS
 1 GUARDS COMPARTMENT

2 X 150 HP. B.U.T. ENGINES.

LOT N
 30419

VEHICLE Nos
 W55000-W55019

BUILT AT
 GLOUCESTER

TARE
 36 T.

GANGWAYED MOTOR OPEN COMPOSITE BRAKE.

B. R. 540

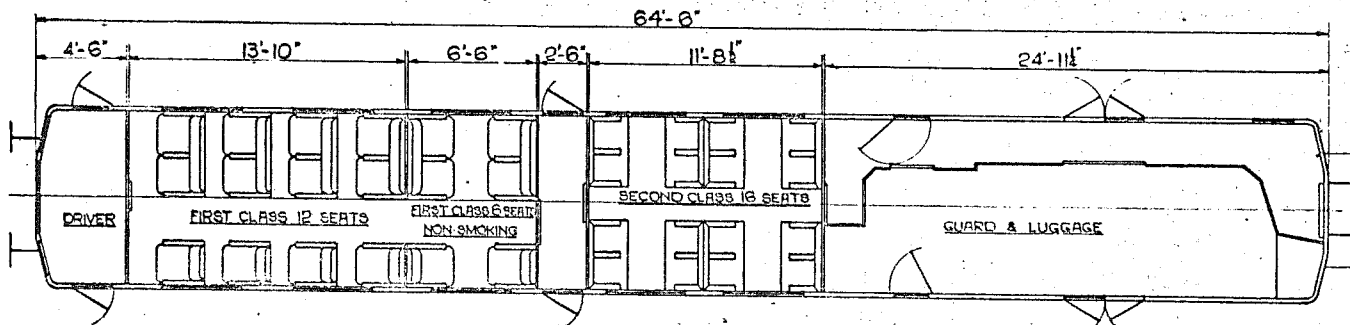
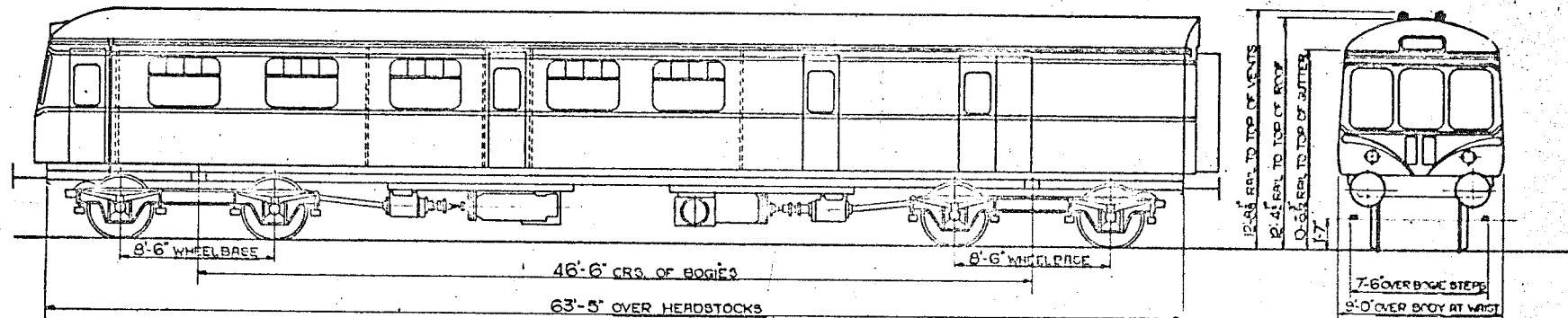

LOT No 30421 VEHICLE Nos W51052-W51079 BUILT AT GLOUCESTER TARE 37 T

- 1 FIRST 18 SEATS
- 1 SECOND 16 SEATS
- 1 DRIVING COMPARTMENT
- 1 GUARD'S COMPARTMENT

2 X 150 HP BUILT ENGINES

GANGWAYED MOTOR OPEN SECOND LAVATORY.

B.R. 541

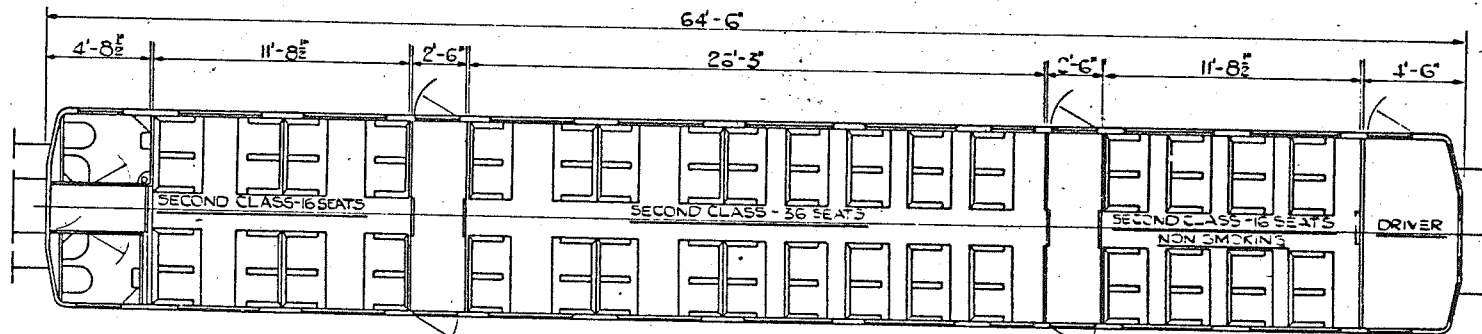
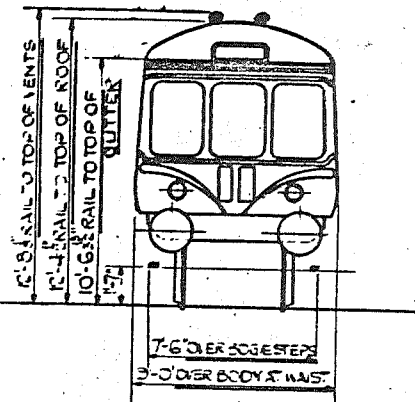
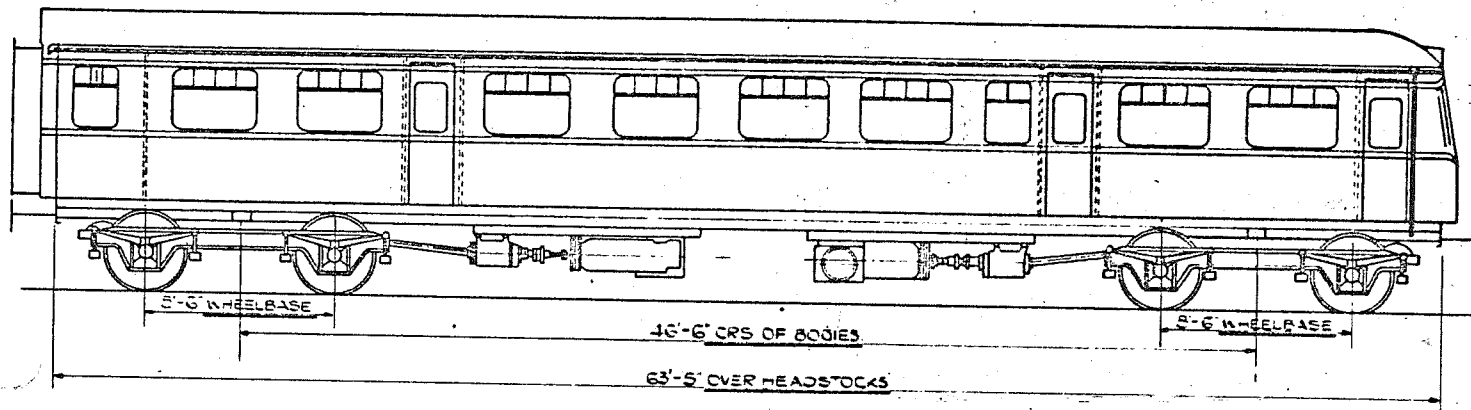

3 SECOND. 68 SEATS.
1 DRIVING COMPARTMENT.
2 LAVATORIES.

2 x 150 H.P. B.U.T. ENGINES

LOT. No.	VEHICLE Nos.	BUILT AT.	TARE
30422	W51080-W51107	GLOUCESTER	38 T

GANGWAYED TRAILER OPEN SECOND LAVATORY BUFFET.

B. R. 542

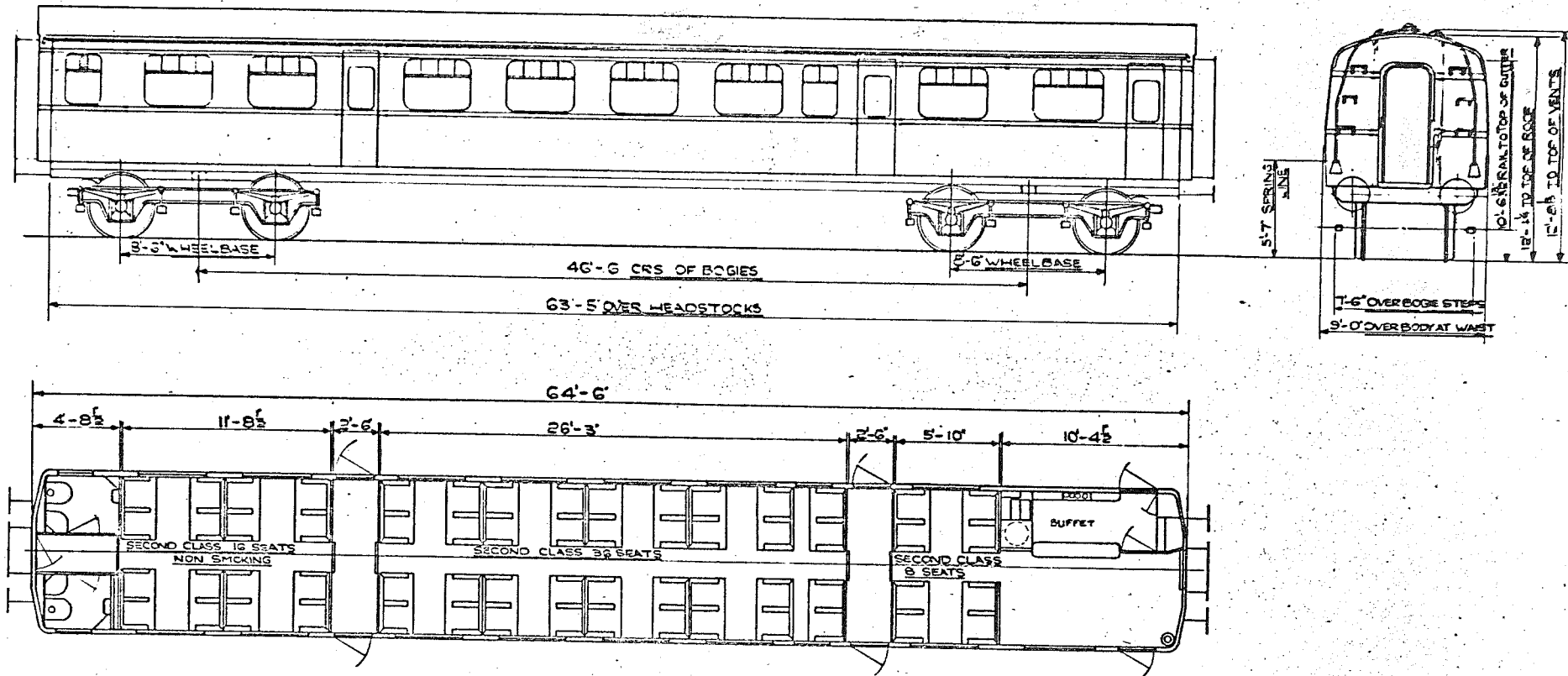

- 3 SECOND 60 SEATS
- 2 LAVATORIES.
- 1 BUFFET.

LOT Nos. VEHICLE Nos. BUILT AT TARE.
 30423 W59413-W59437 GLOUCESTER 31 T

GANGWAYED MOTOR OPEN SECOND BRAKE.

B. R. 543

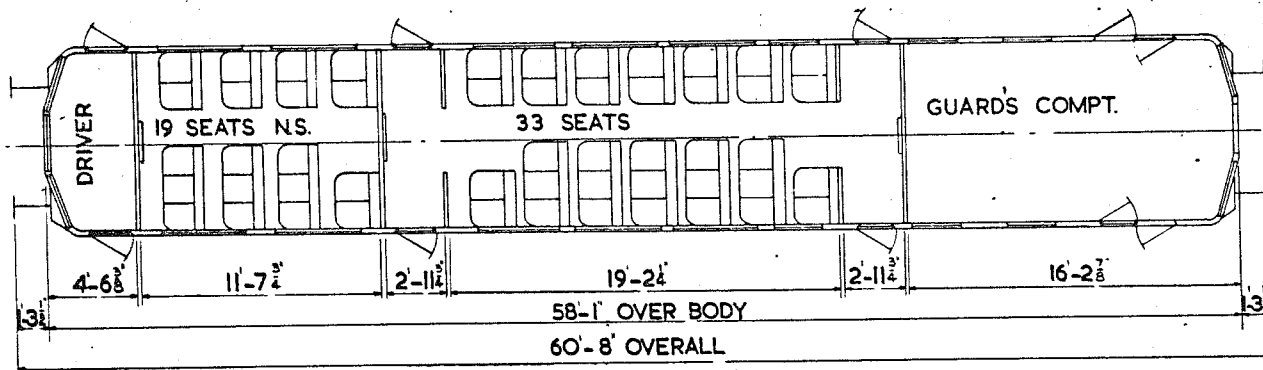
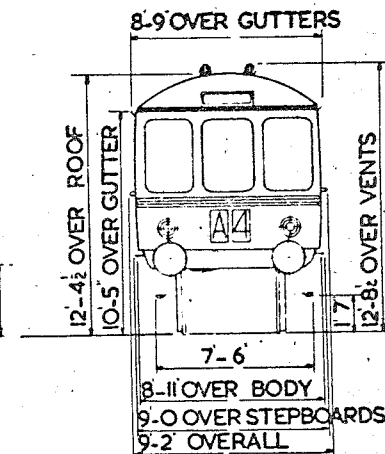
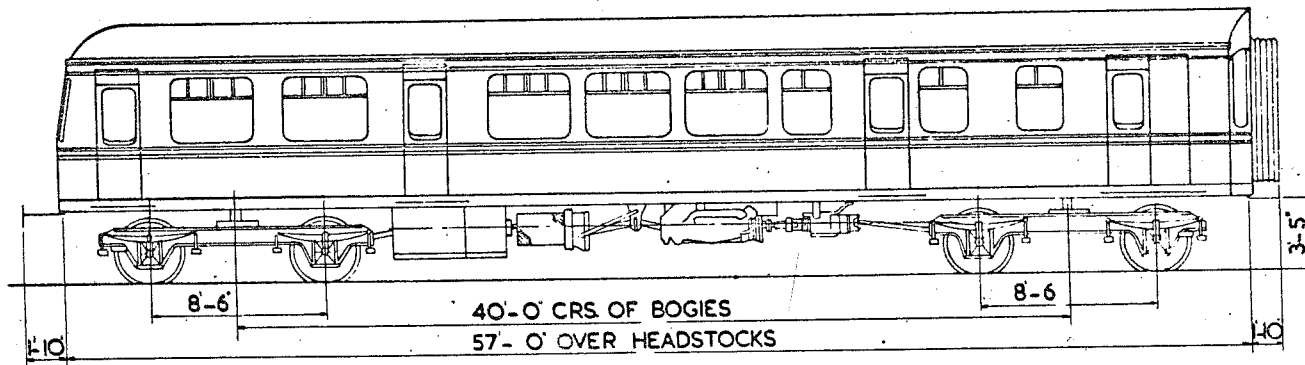

LOT No	VEHICLE Nos.	BUILT AT	TARE
30406	E 50599 - E 50624	DERBY	29 T
30407	M 50625 - M 50629		
30460	M 50924 - M 50935		
30465	M 50938 - M 50987		

2 SECOND 52 SEATS.
 1 DRIVING COMPARTMENT.
 1 GUARDS COMPARTMENT.
 N.S. NON SMOKING.

2 X 150 H.P. B.U.T. ENGINES.

GANGWAYED MOTOR OPEN COMPOSITE LAVATORY.

*London
North*

B. R. 544

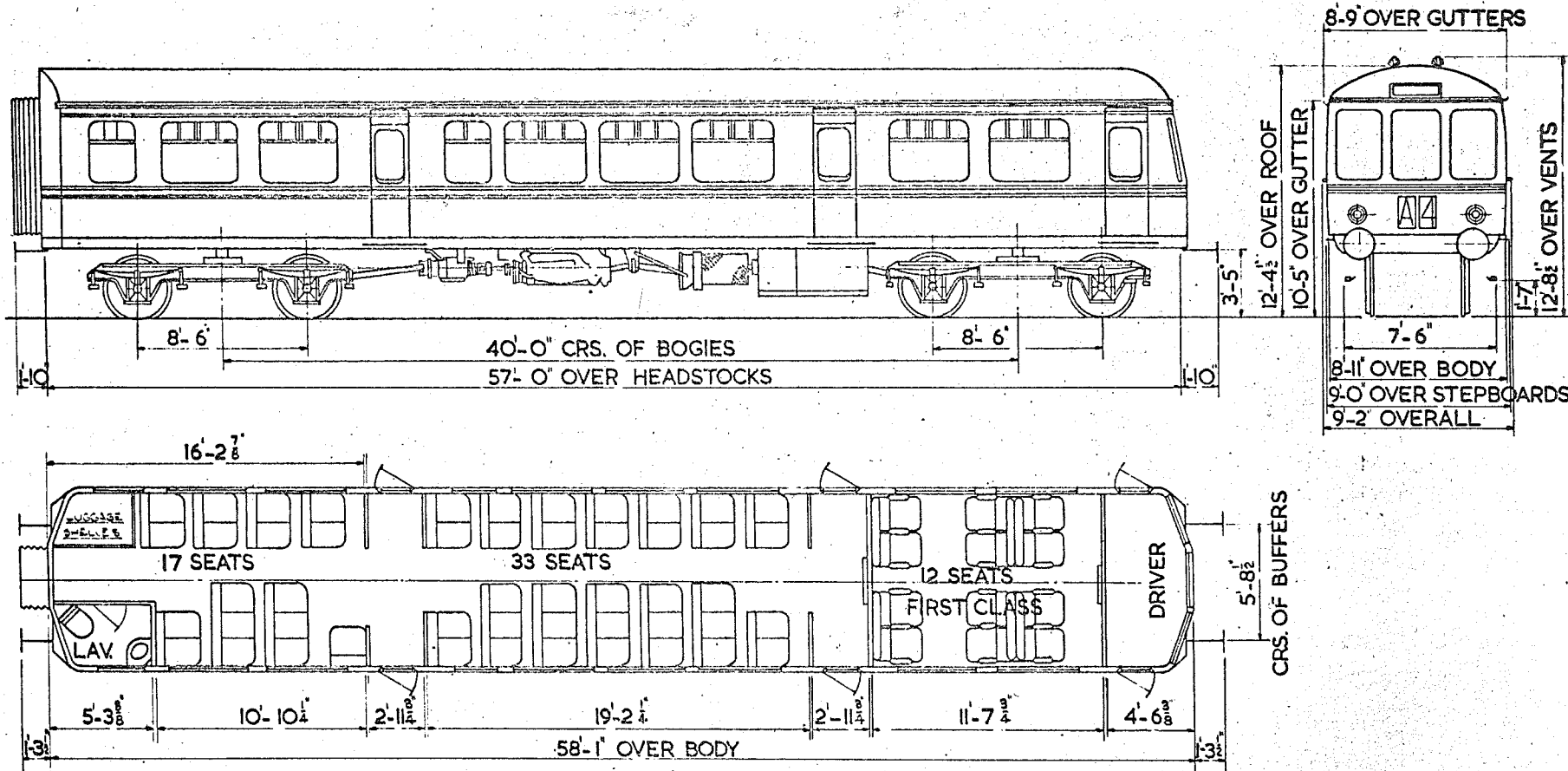

- 1 FIRST. 12 SEATS.
- 2 SECOND. 50 SEATS.
- 1 DRIVING COMPARTMENT.
- 1 LAVATORY

2 x 150 H.P. B.U.T. ENGINES.

LOT. No.
408

VEHICLE Nos. BUILT AT.
E50630-E50646 DERBY

TARE.
28 T

GANGWAYED TRAILER OPEN SECOND LAVATORY

B. R. 545

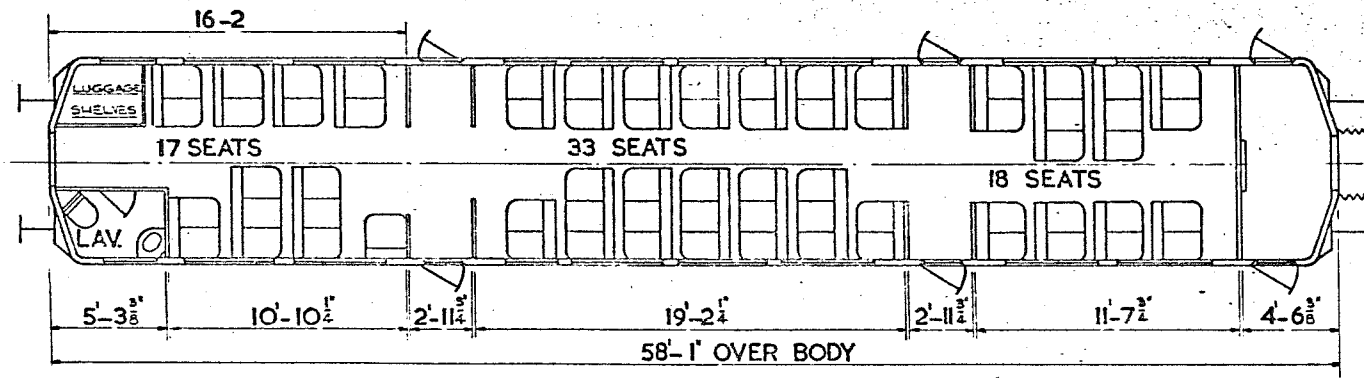
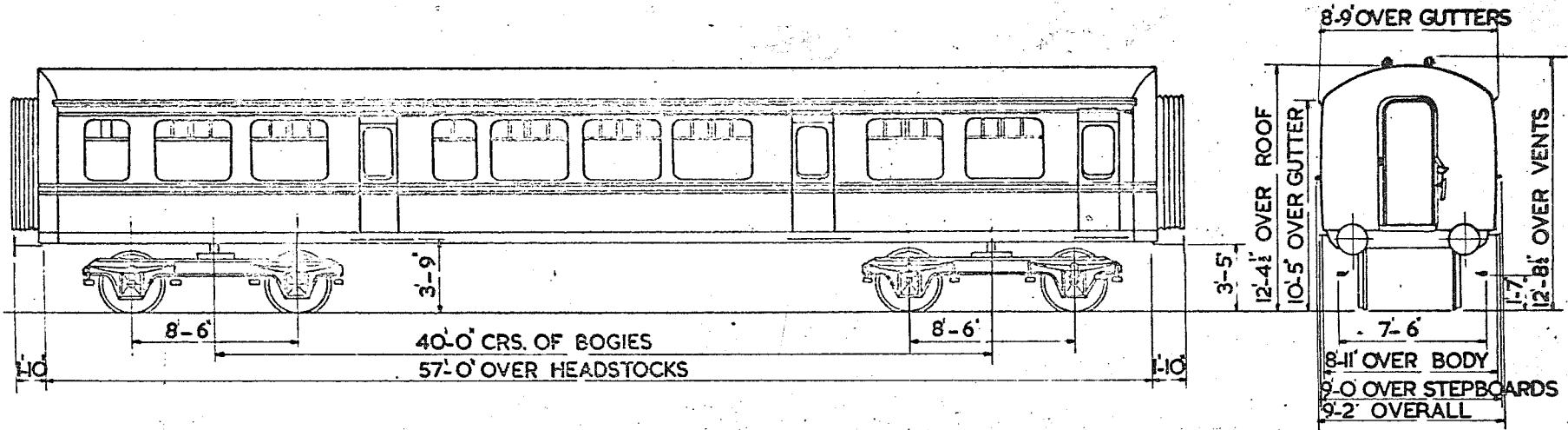

LOT Nos.	VEHICLE Nos.	BUILT AT	TARE
30493	E59386 - E59390	DERBY	23T

3 SECOND 68 SEATS
LAVATORY

GANGWAYED TRAILER OPEN SECOND BRAKE LAVATORY.

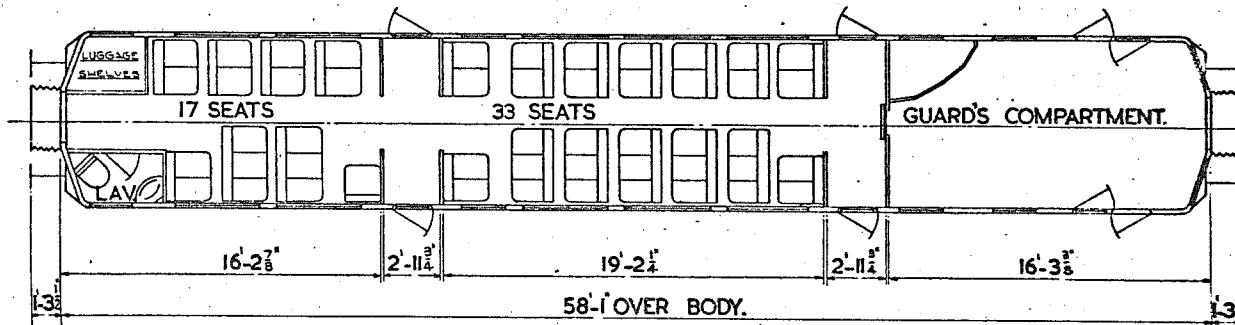
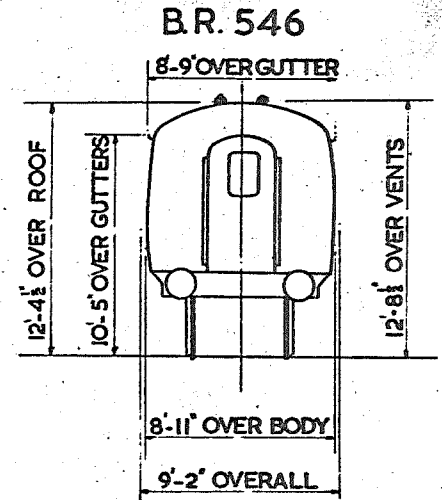
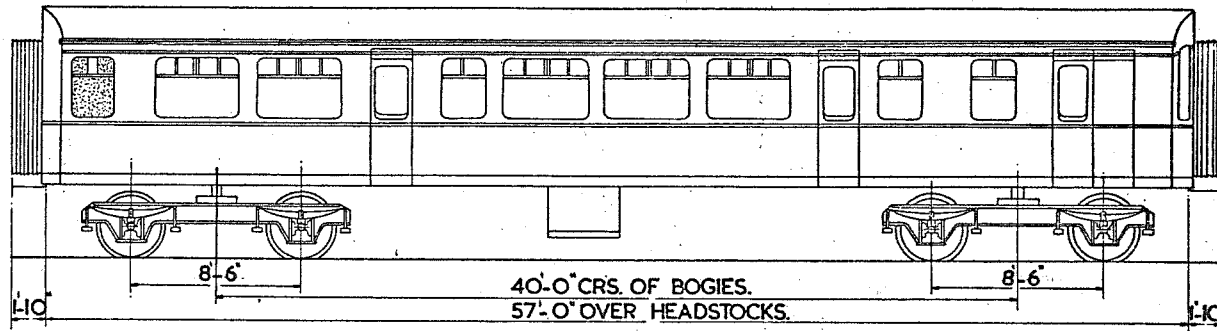

2 SECOND. 50 SEATS.
1 LAVATORY.
1 GUARDS COMPARTMENT.

LOT. No.
30412

VEHICLE Nos.
E59245-E59250

BUILT AT
DERBY

TARE
23 T

GANGWATED TRAILER OPEN SECOND LAVATORY.

B.R. 547

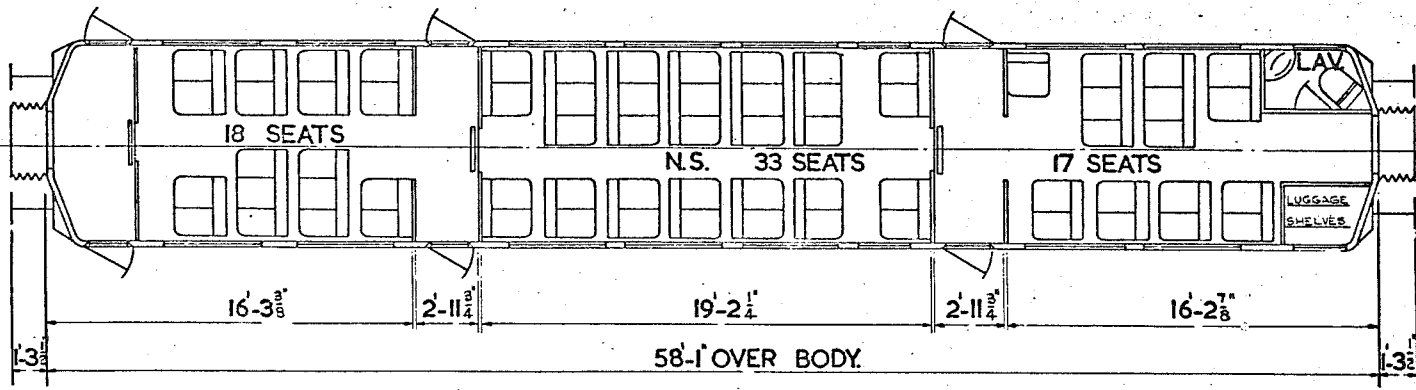
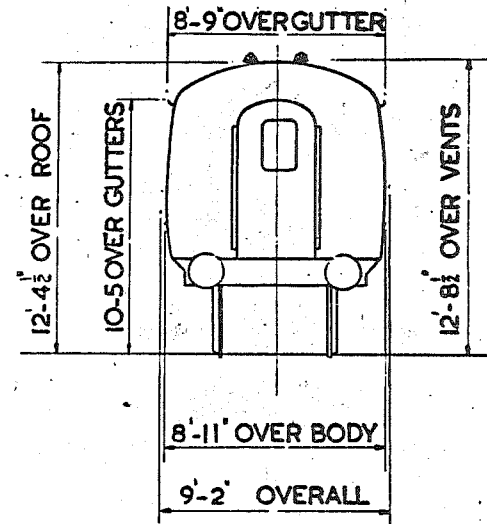
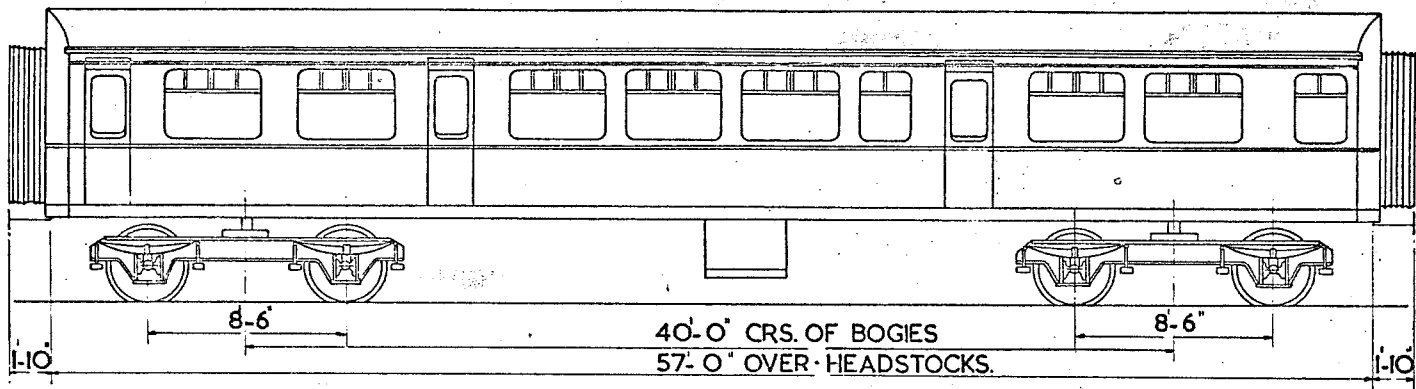

3 SECOND. 68 SEATS.
1 LAVATORY.
N.S. - NON SMOKING.

LOT No. 30411
VEHICLE Nos. E59380-E59385

BUILT AT DERBY
TARE 22T.

B.R. 548

GANGWAYED MOTOR OPEN SECOND BRAKE.

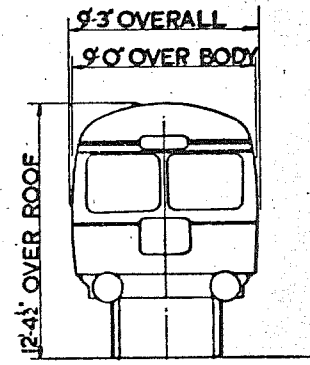
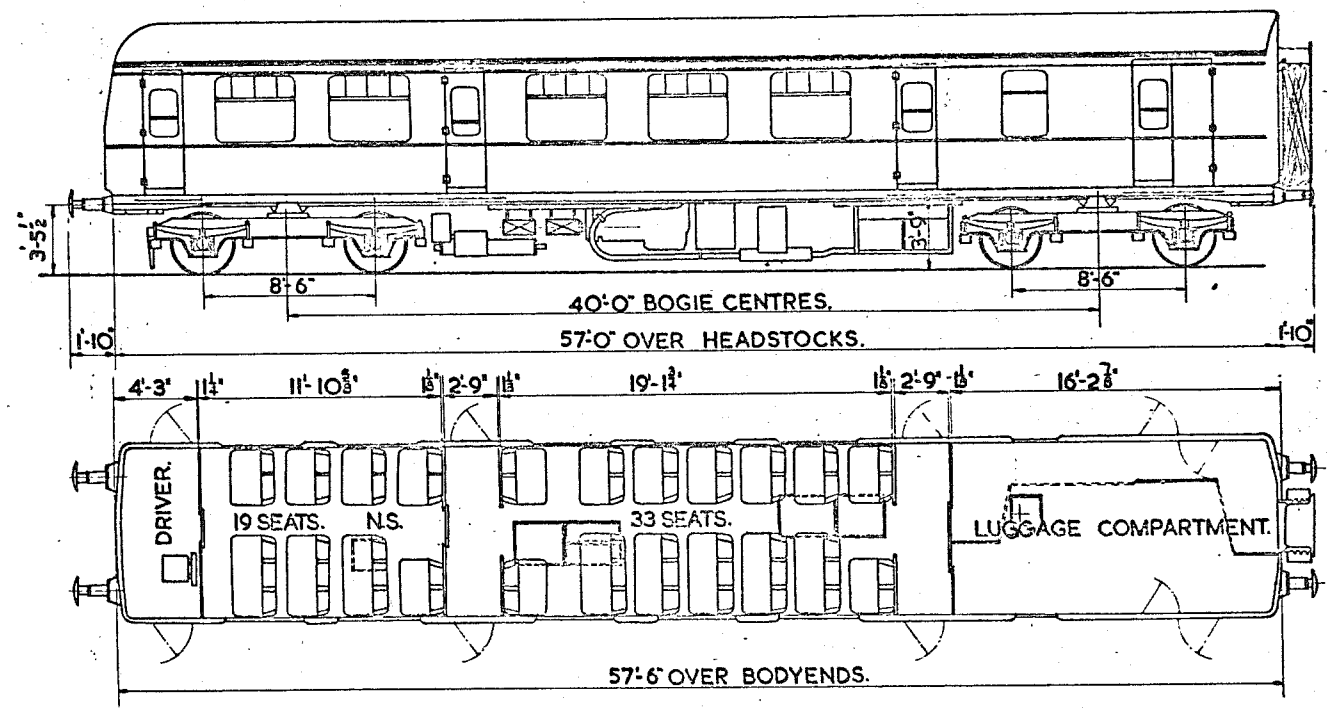

- 2 SECOND. 52 SEATS
- 1 DRIVING COMPARTMENT.
- 1 LUGGAGE COMPARTMENT.
- 2 X 15 H.P. B.U.T. ENGINES.

NS. NON-SMOKING.

LOT Nos	VEHICLE Nos	BUILT AT	TARE
30503	E51471 - E51472	CRAVENS	30T
30503	SC51473 - SC51494	"	"
30505	E 50249	"	"

BR 549

GANGWAYED TRAILER COMPOSITE LAVATORY.

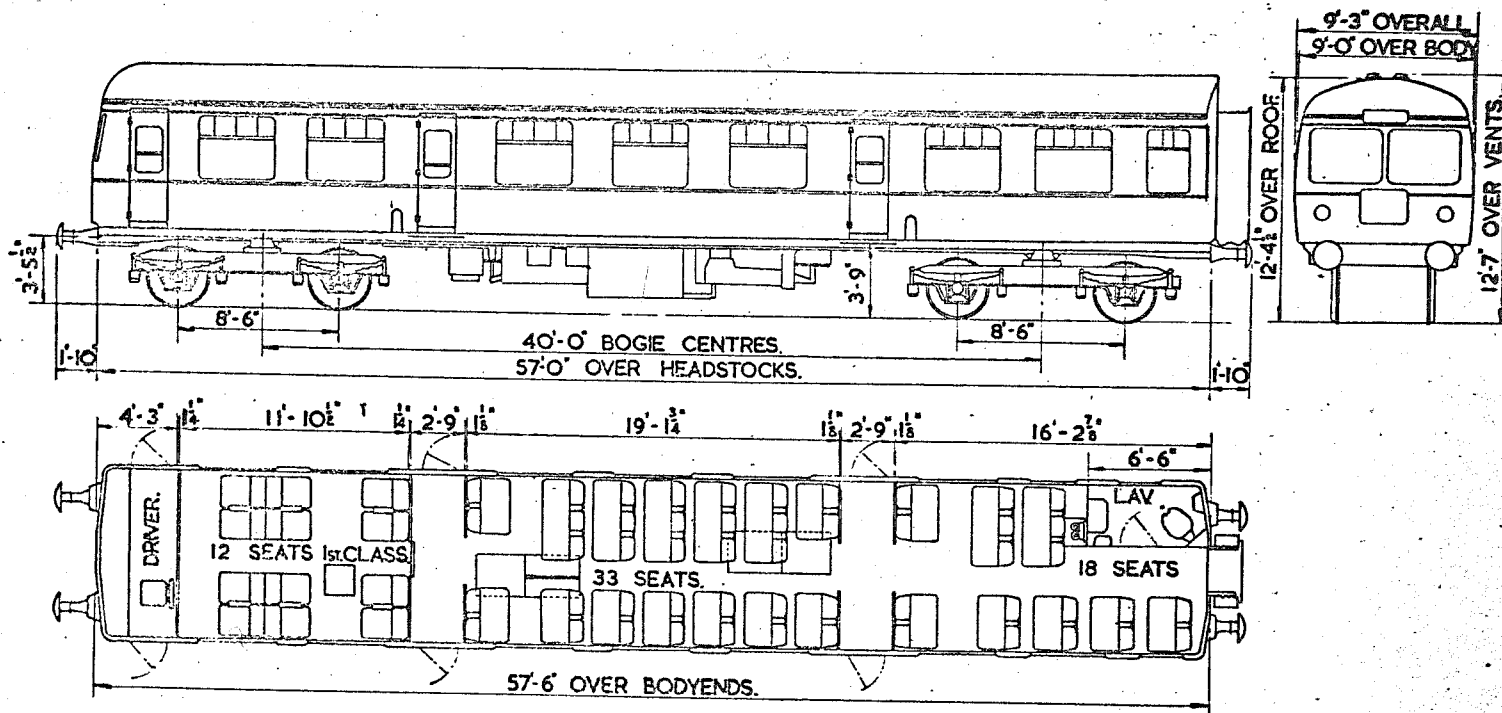

- 1 FIRST 12 SEATS.
- 2 SECOND 51 SEATS.
- 1 DRIVING COMPARTMENT.
- 1 LAVATORY.

LOT No.	VEHICLE Nos.	BUILT AT	TARE
30504	E 56460-E56461	CRAVENS	23 T.
30504	SC56462-SC56483	.	.

NON GANGWAYED MOTOR OPEN SECOND BRAKE.

B.R.553.

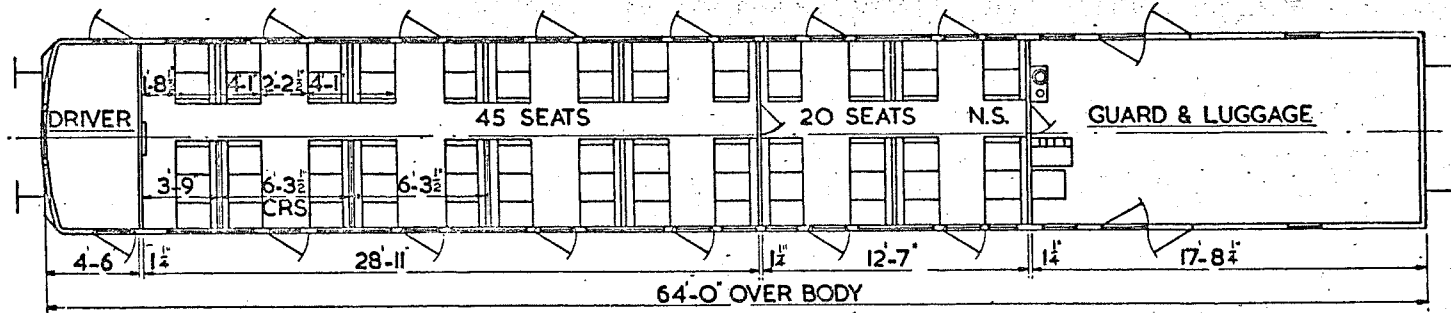
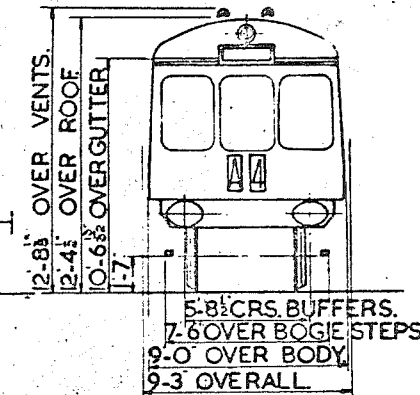
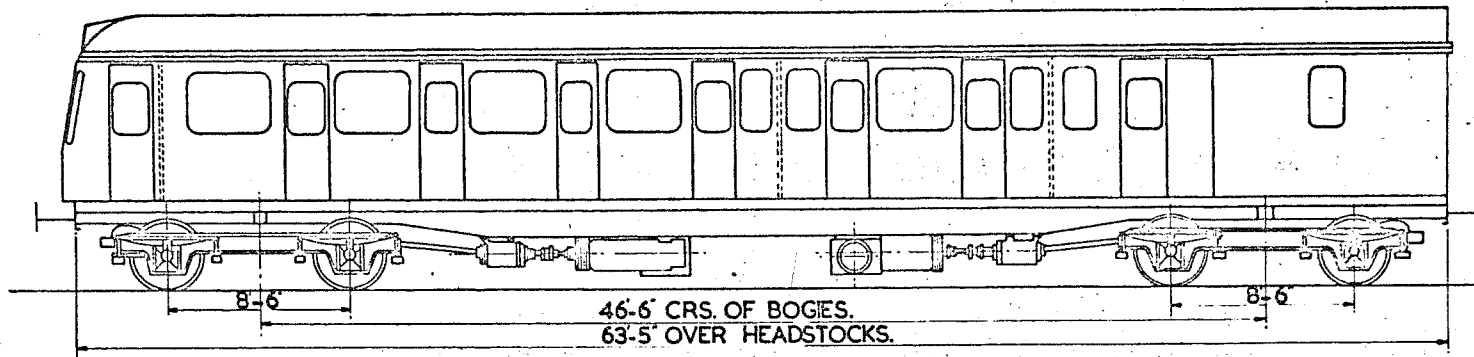

N.S. - NON SMOKING.
S. - SMOKING.

2 X 150 H.P. B.U.T. ENGINES.

2 SECOND 65 SEATS.
1 DRIVING COMPARTMENT.
1 GUARDS COMPARTMENT.
N.S. NON SMOKING.

LOT No.	VEH. No.	BUILT AT	TARE
30211	W50050 - W50091	DERBY	36T
30363	W50818 - W50870	.	.
30446	W51128 - W51140	.	.

NON GANGWAYED MOTOR OPEN SECOND.

B.R. 554.

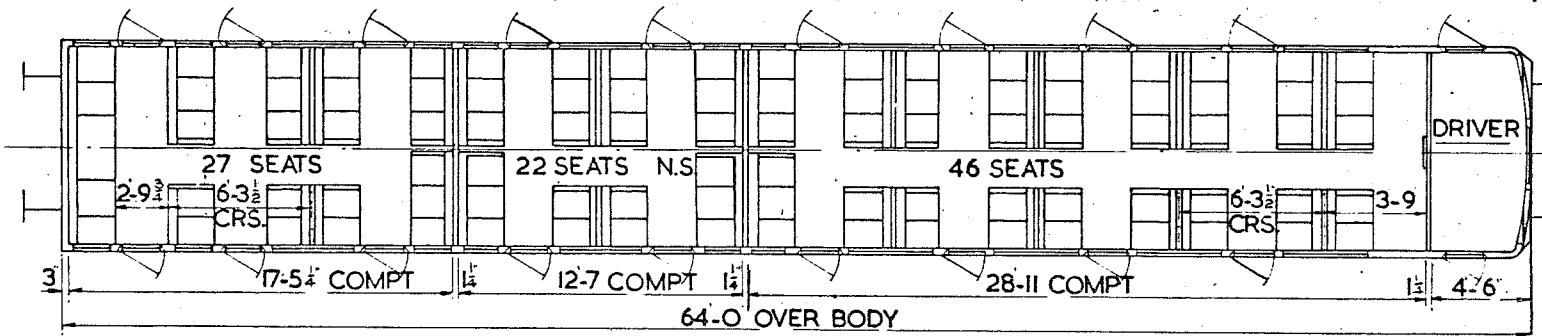
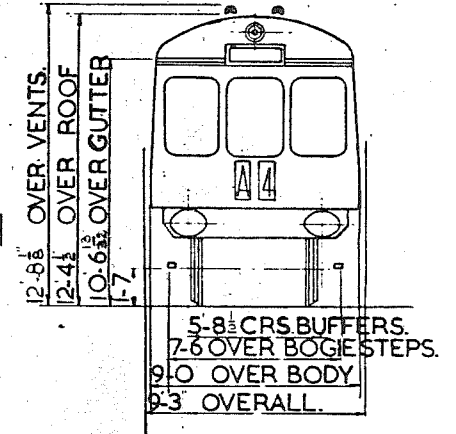
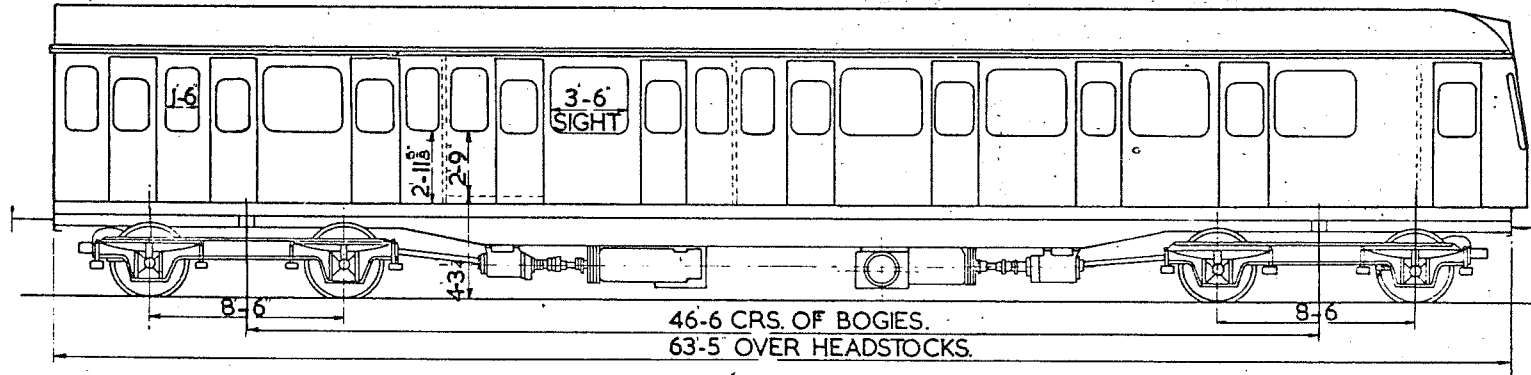

N.S. - NON SMOKING

3 SECOND 95 SECOND
1 DRIVING COMPARTMENT

2 X 150 H.P. B.U.T. ENGINES

LOT No.	VEH. No.
30213	W50092-W50133
30364	W50871-W50923
30447	W51141-W51153

BUILT AT	TARE
DERBY	36 TONS

NON GANGWAYED TRAILER COMPOSITE.

B.R. 555

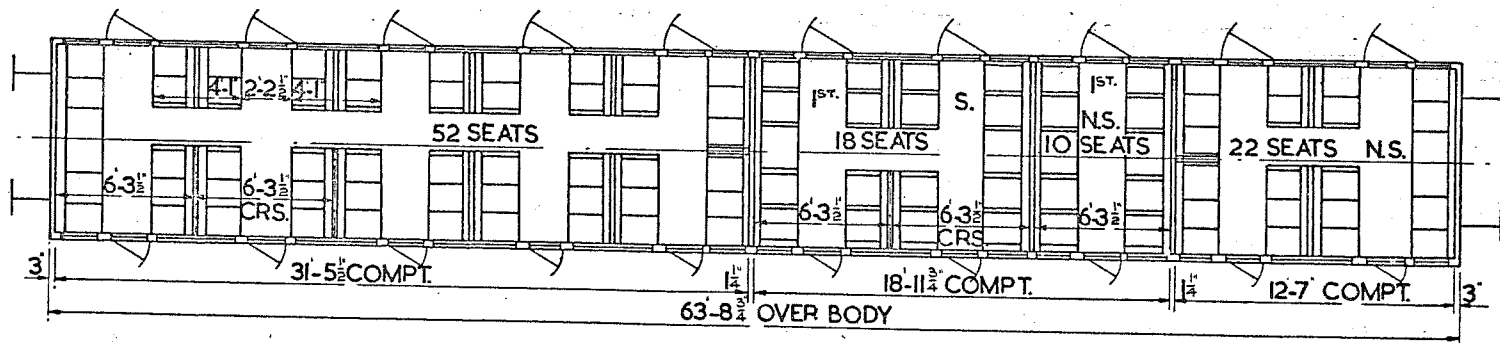
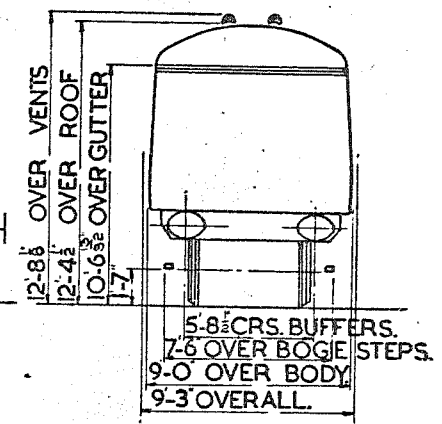
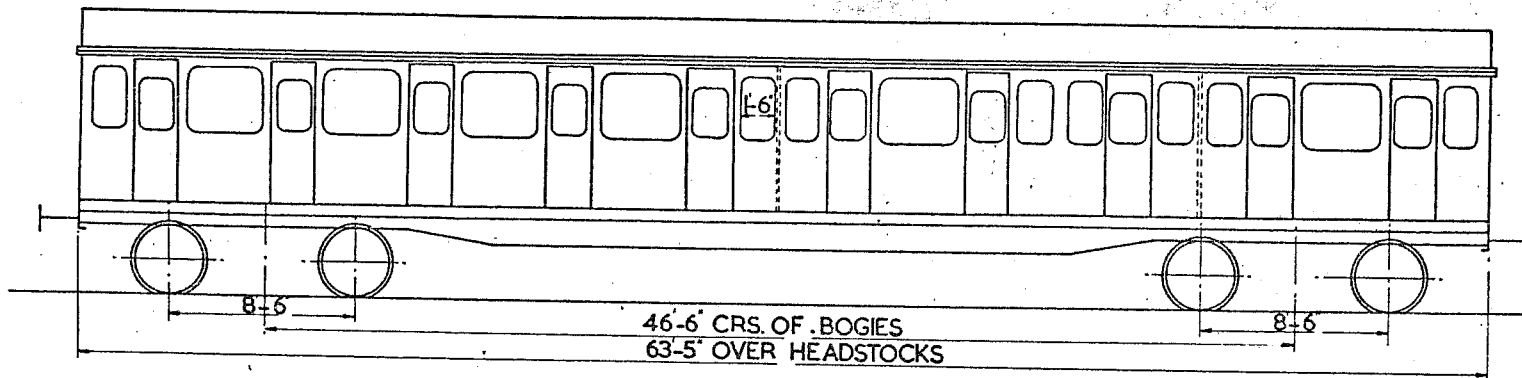

N.S. - NON SMOKING

2 FIRST 28 SEATS
2 SECOND 74 SEATS

LOT No.
30212
30365
30448

VEH. No.
W59000-W59031
W59326 -W59376
W59438 -W59448

BUILT AT
DERBY

TARE
28T IOC

GANGWAYED MOTOR OPEN SECOND BRAKE.

BR 556.

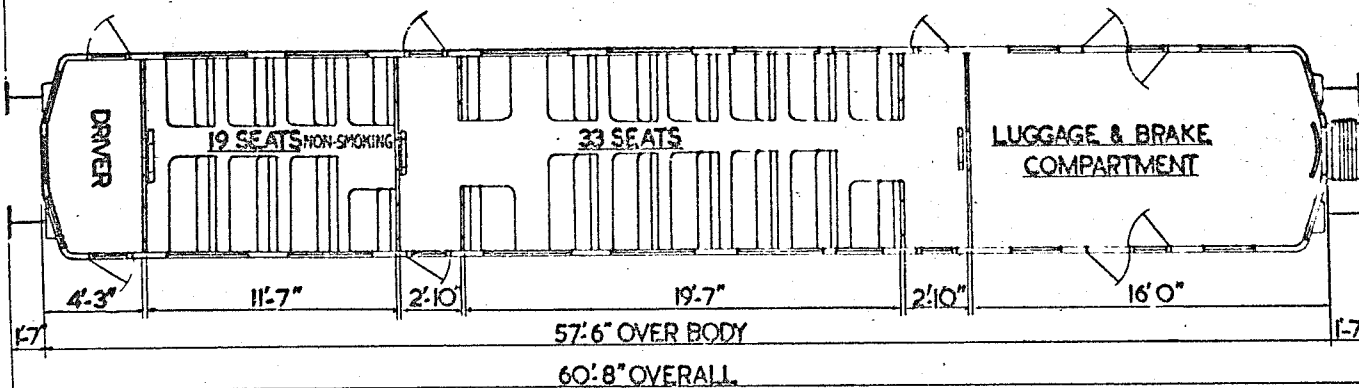
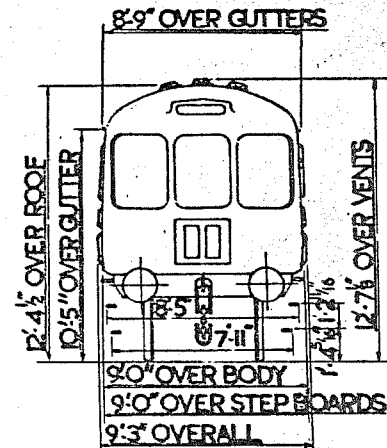
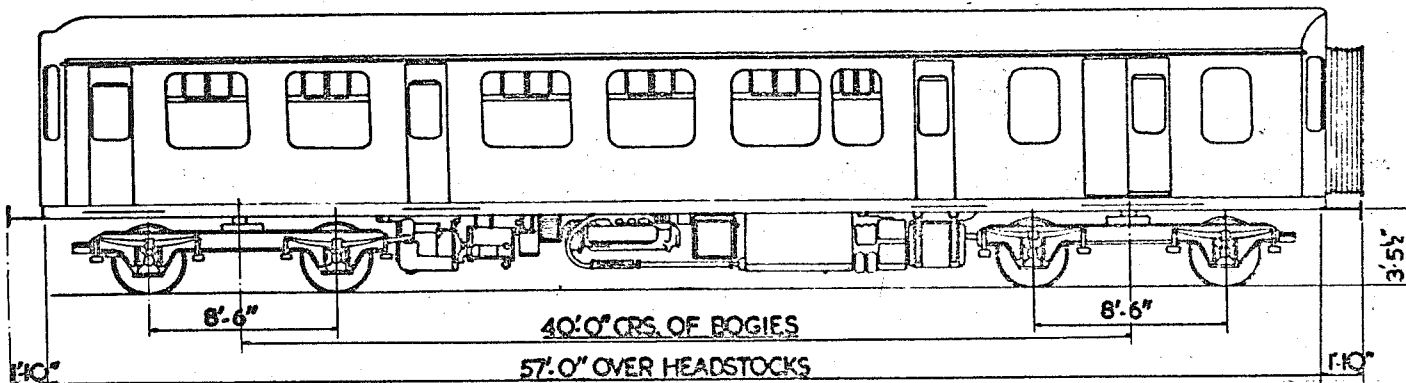

2 SECOND. 52 SEATS.
 1 DRIVING COMPARTMENT.
 1 LUGGAGE & BRAKE COMPARTMENT

2x150 H.P.B.U.T. ENGINES.

LOT No.
 30290
 30293
 30296

VEHICLE Nos.
 M50420-M50423.
 M50428-M50479.
 M50532-M50541.

BUILT AT
 BIRMINGHAM RLY C.&W. Co.

TARE
 31 T.

GANGWAYED MOTOR OPEN SECOND BRAKE.

B.R. 557

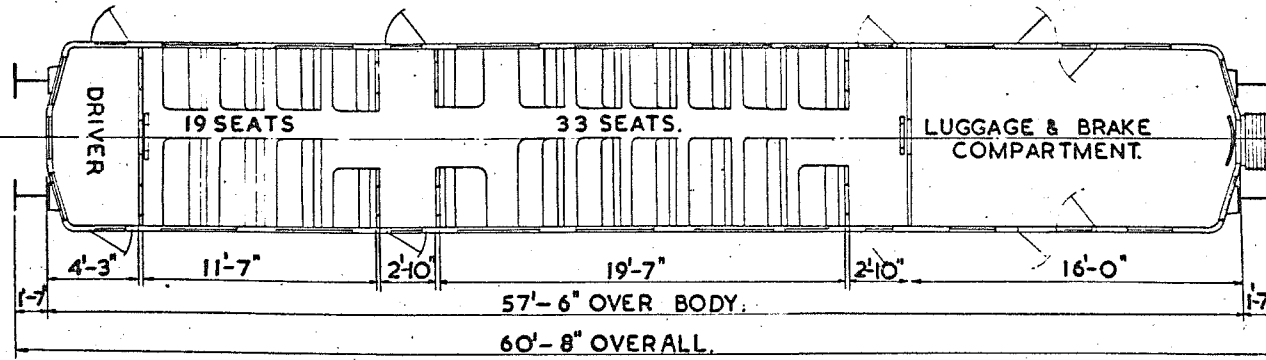
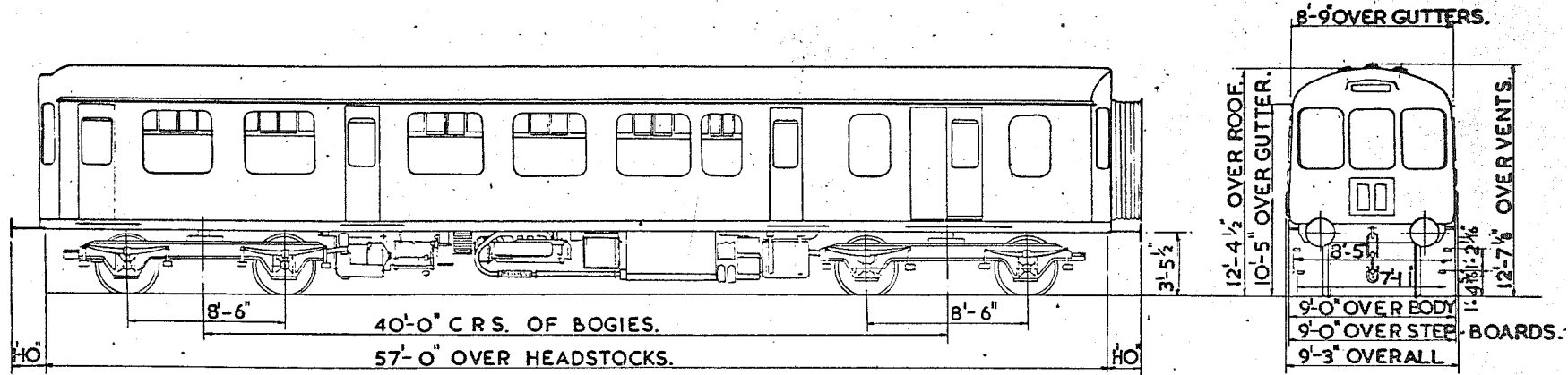

2 SECOND. 52 SEATS.
 1 DRIVING COMPARTMENT.
 1 LUGGAGE & BRAKE COMPARTMENT.

2x150 H.P. B.U.T. ENGINES.

LOT No.
 30404.

VEHICLE Nos.
 O594-E 50598

BUILT AT
 BIRMINGHAM RLY. C&W. Co.

TARE
 31 T.

GANGWAYED MOTOR OPEN COMPOSITE LAVATORY.

B.R. 558.

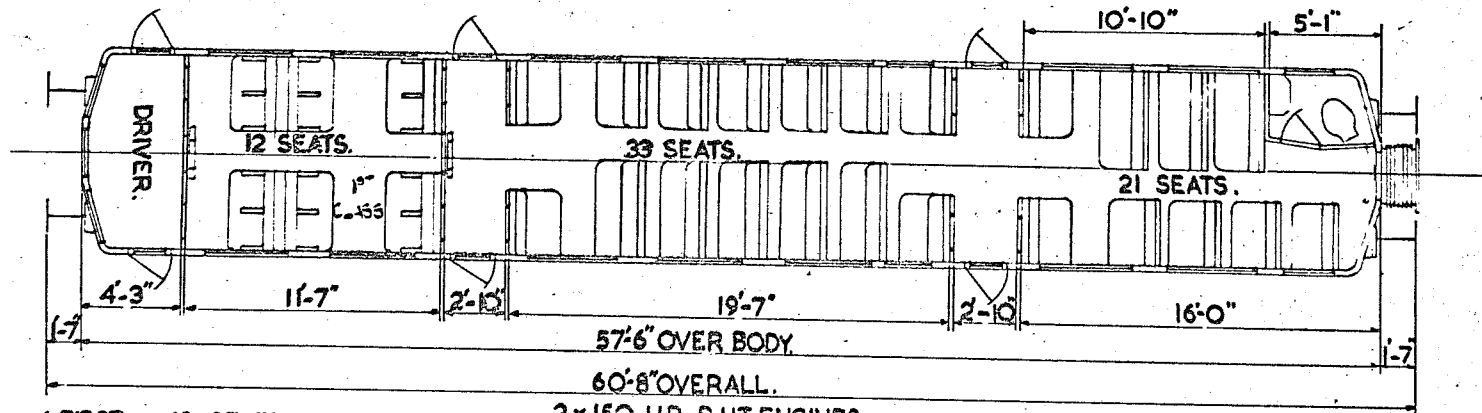
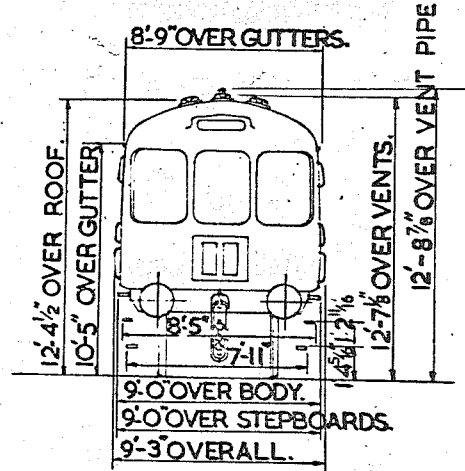
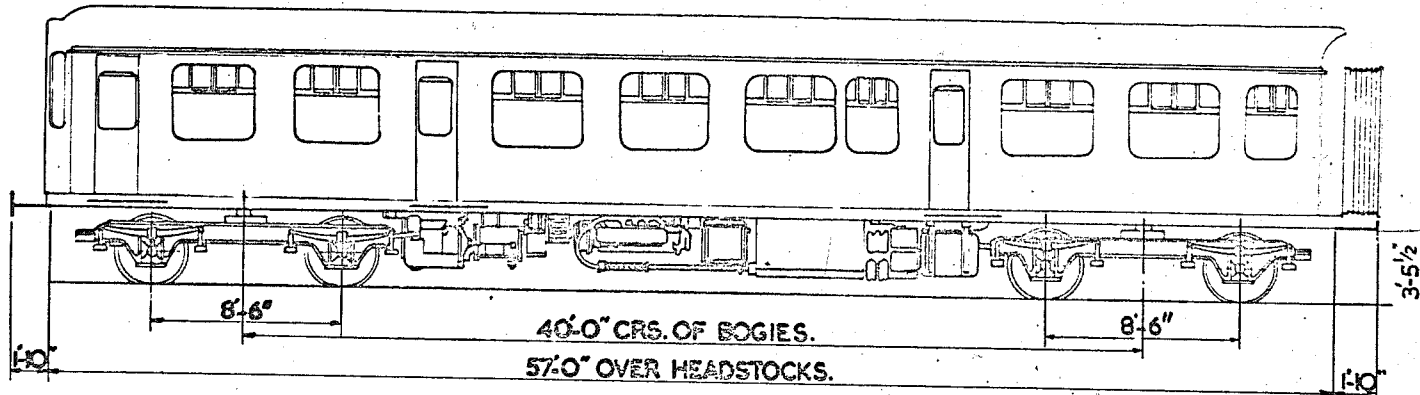

- 1 FIRST. 12 SEATS.
- 2 SECOND. 54 SEATS.
- 1 DRIVING COMPARTMENT.
- 1 LAVATORY.

2 x 150 H.P. B.U.T. ENGINES.

LOT No.
30291
30294

VEHICLE Nos.
M 5024-M 50427
M 50480-M 50531

BUILT AT
BIRMINGHAM RLY. C&W. Co.

TARE
31 T.

GANGWAYED MOTOR OPEN COMPOSITE LAVATORY.

B.R. 559

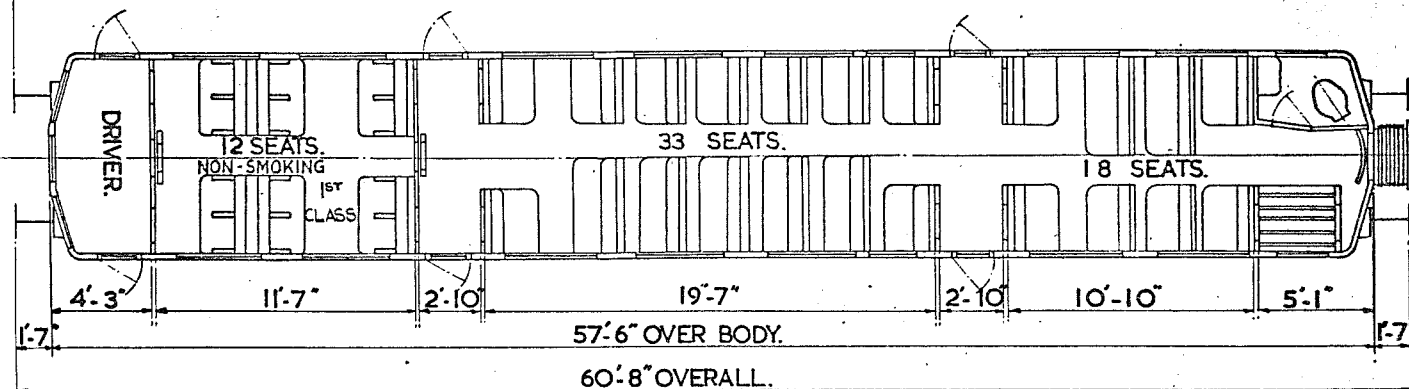
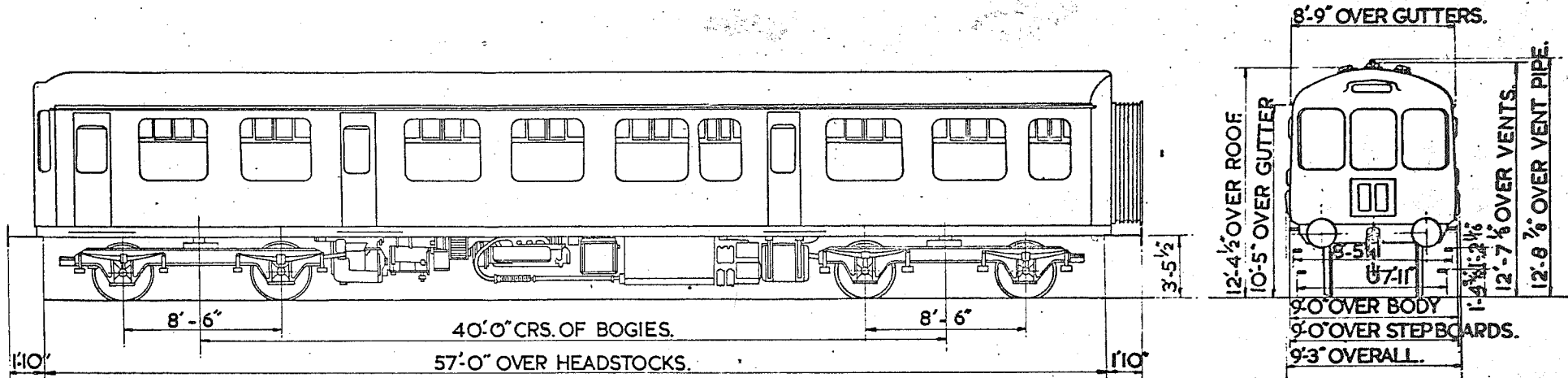

- 1 FIRST 12 SEATS.
- 2 SECOND 51 SEATS.
- 1 DRIVING COMPARTMENT.
- 1 LAVATORY

2x150 H.P. B.U.T. ENGINES.

LOT No.
30298
30301

VEHICLE Nos.
E 50563 - E 50583
L 50589 - E 50593

BUILT AT
BIRMINGHAM RLY. C&W Co.

TARE
31 T

TRAILER SECOND
WITH BUFFET
CROSS COUNTRY DIESEL TRAIN

B.R. 561

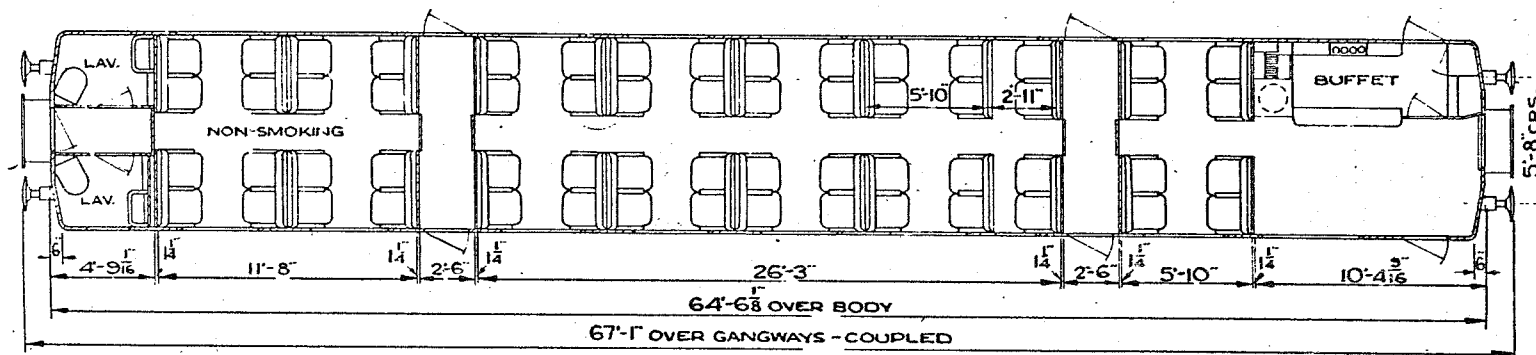
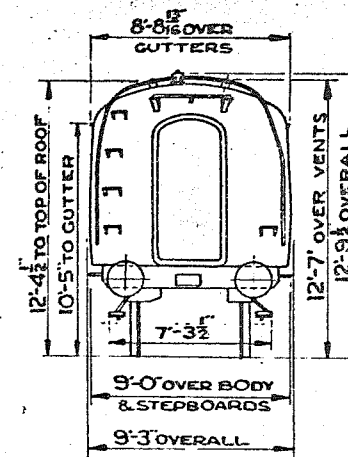
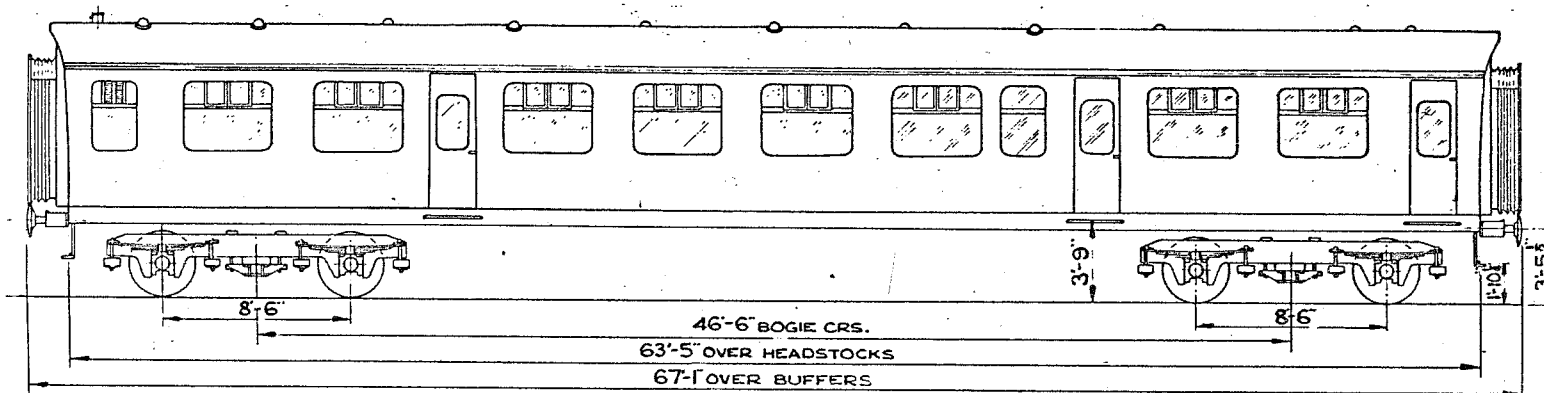

QTY.	LOT.	TARE TONS.CWTS.	BUILT AT
47	30336	30 - 12	SWINDON

SECOND CLASS - 60 SEATS.
 2 LAVATORIES. 1 BUFFET.



TRAILER FIRST BUFFET
INTER-CITIES DIESEL TRAINS

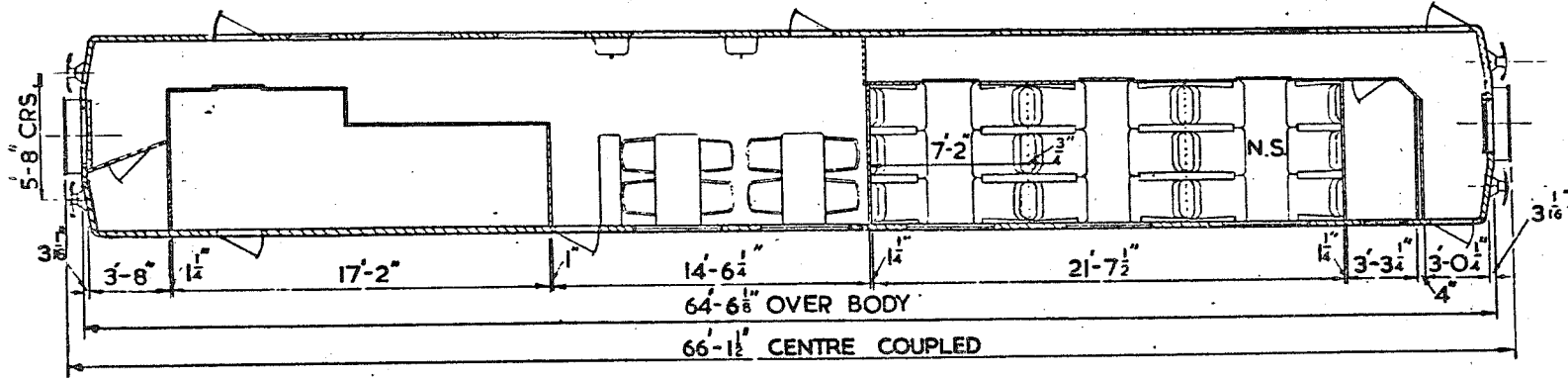
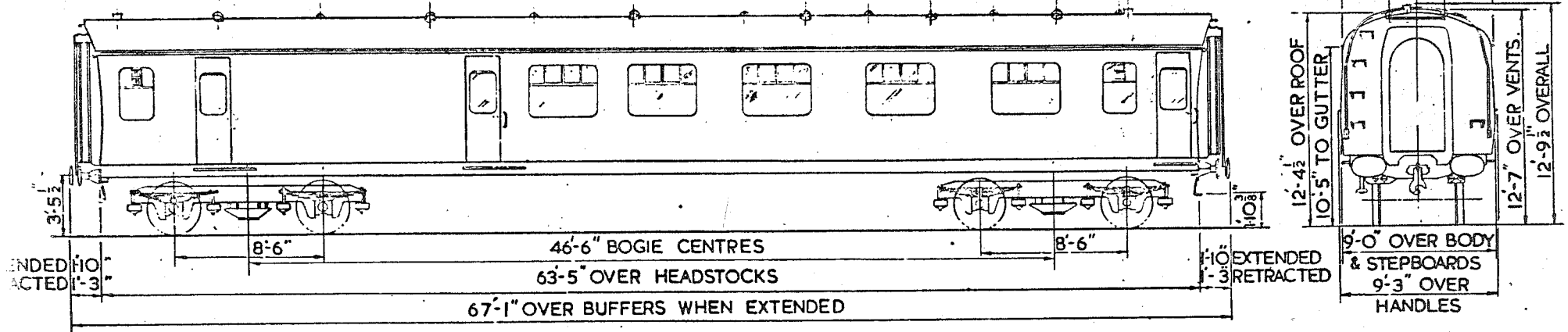

FIRST CLASS. 18 SEATS	QTY.	VEHICLE	LOT NO	BUILT AT	TARE
1 PASSENGERS' LAVATORY	8	E.59774 - E.59781	30606	SWINDON	34 TONS WTS.
1 STAFF LAVATORY					



GANGWAYED MOTOR OPEN COMPOSITE LAVATORY

B.R. 563

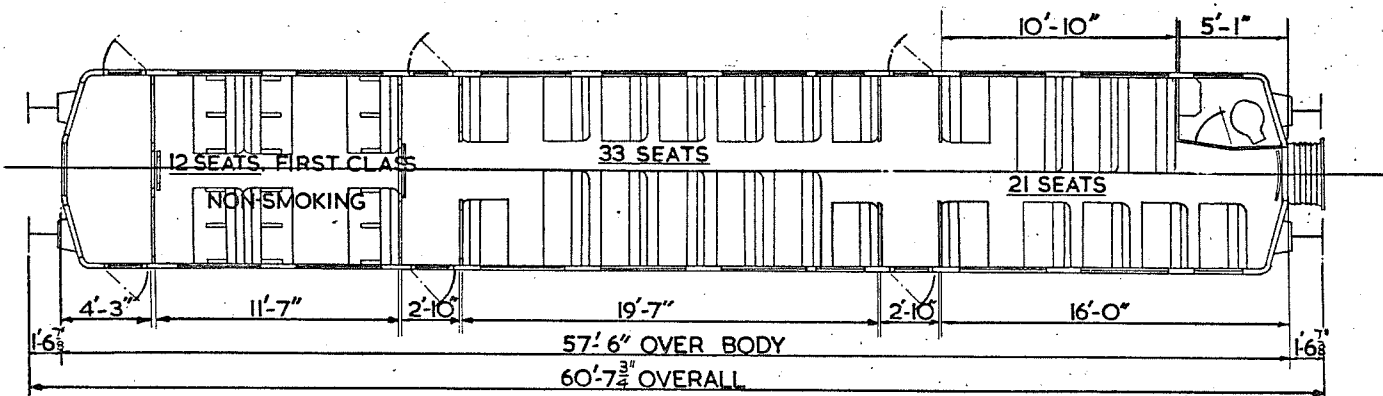
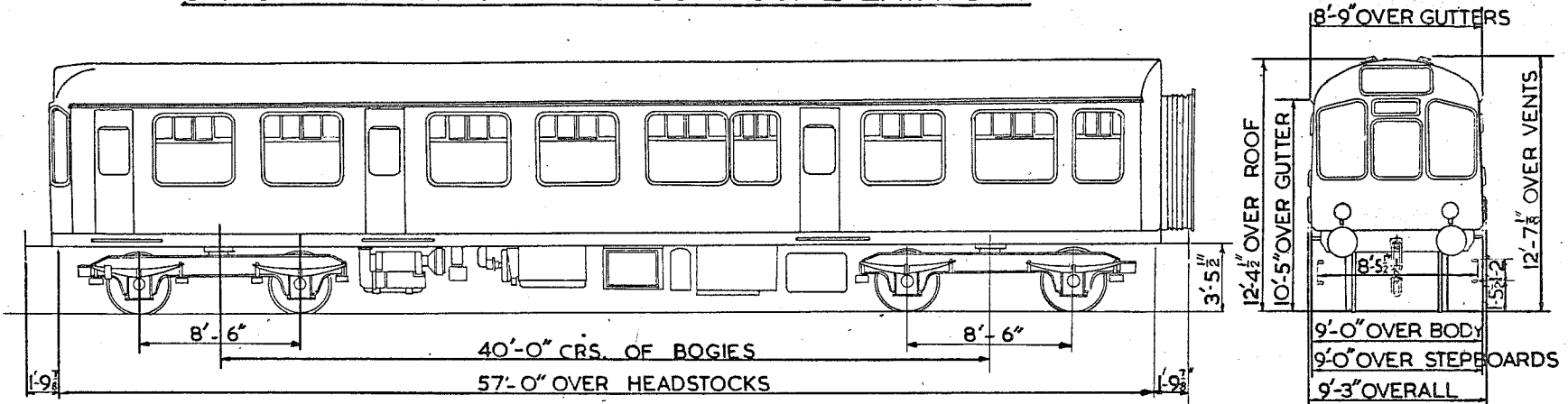

- 1 FIRST 12 SEATS
- 2 SECOND 54 SEATS
- 1 DRIVING COMPARTMENT
- 1 LAVATORY

2 X 180 H.P ROLLS ROYCE ENGINES

LOT No.
3-193

VEHICLE No.S.
E51829 - E51848

BUILT AT
BIRM'HM. RLY. C & W. Co.

TARE

SPECIAL SALOON

B.R. 565

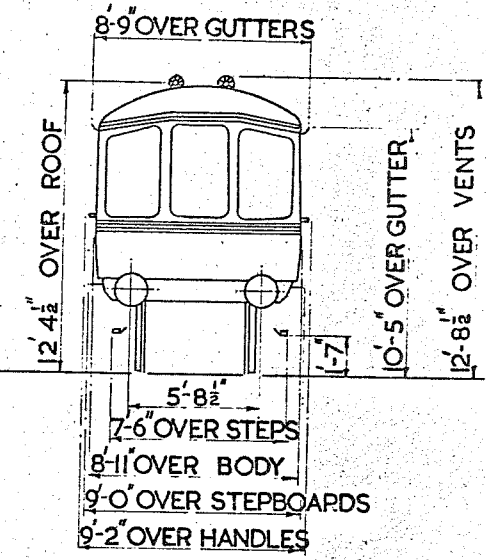
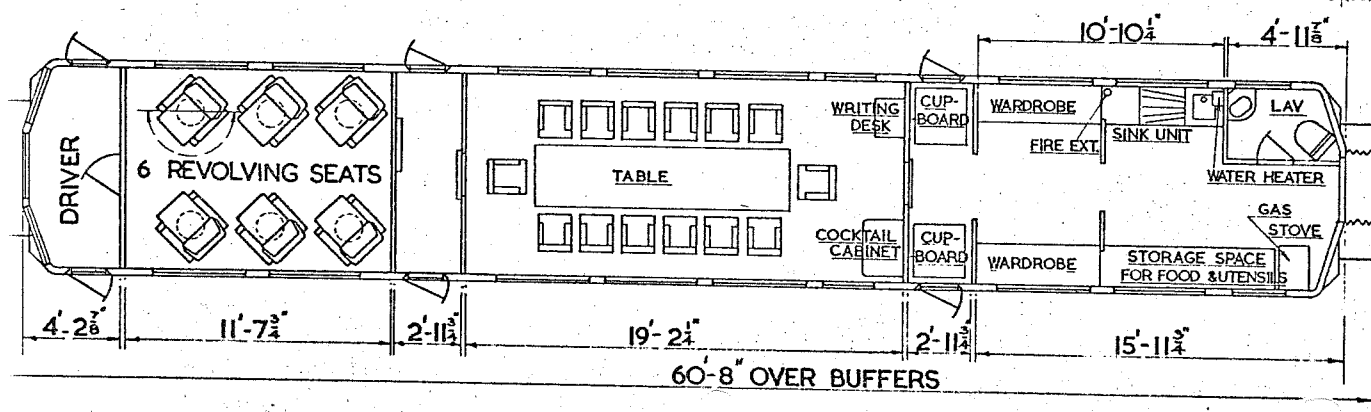
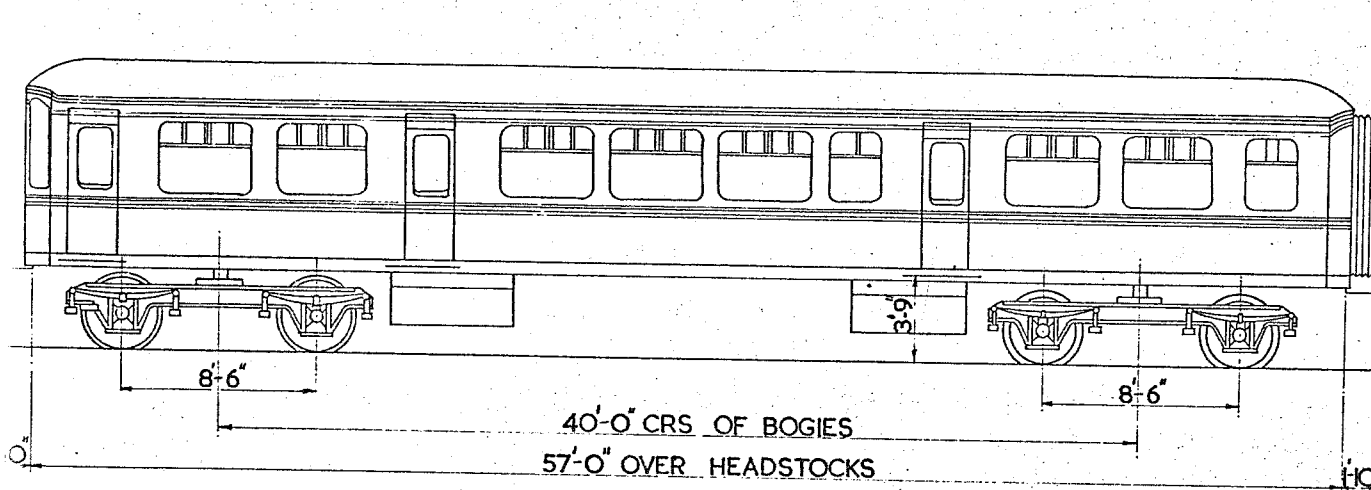

VEHICLE No M.79649
 CONVERTED 1957 FROM LOT 30241
 DRIVING TRAILER OPEN COMPOSITE.

TARE. 23 TONS.

MOTOR BRAKE SECOND I-C.D.T. B-S

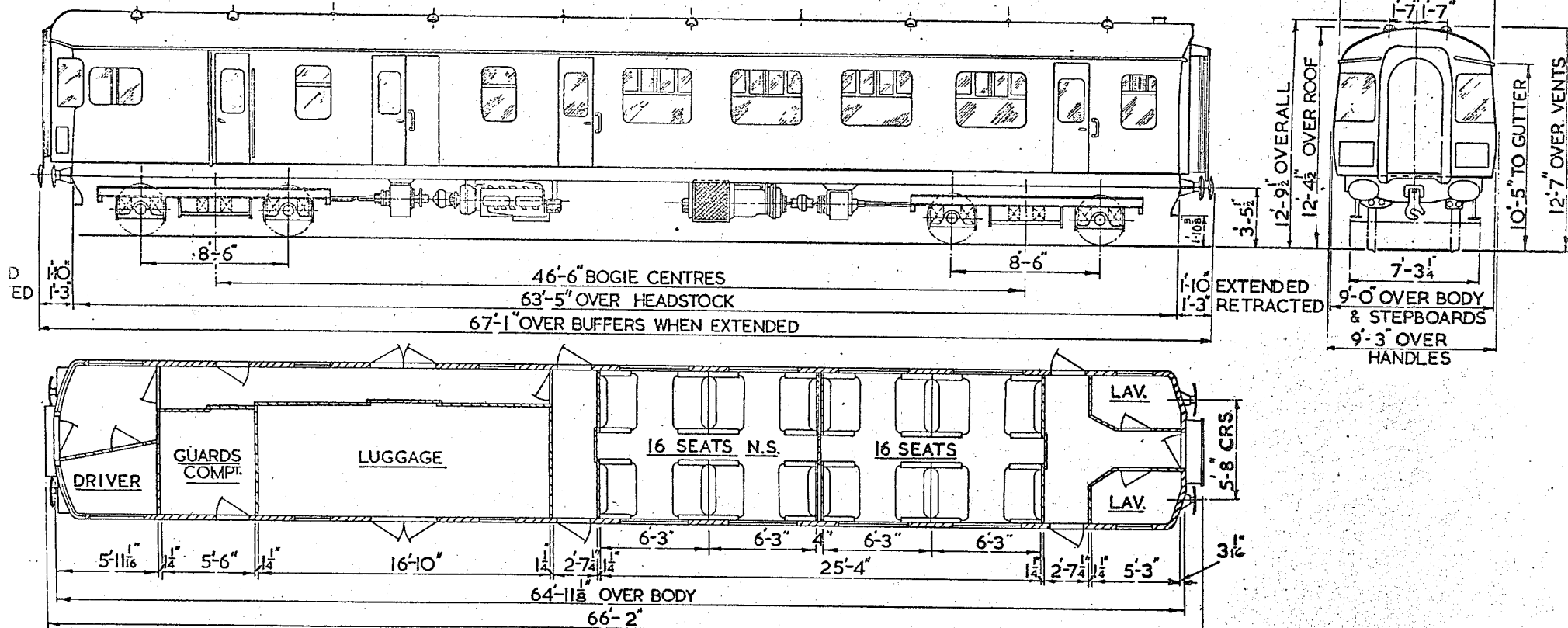

SECOND CLASS 32 SEATS	QTY.	VEH. NO	LOT	BUILT AT	TARE	ENGINES
2 LAVATORIES	10	W 52086 TO	30703	SWINDON	41 TONS 14 CWTS.	2 x 230 B.H.P.
1 GUARDS COMP.		W 52096				
1 LUGGAGE COMP.						



TRAILER COMPOSITE I-C.D.T. B-S.

B.R. 567

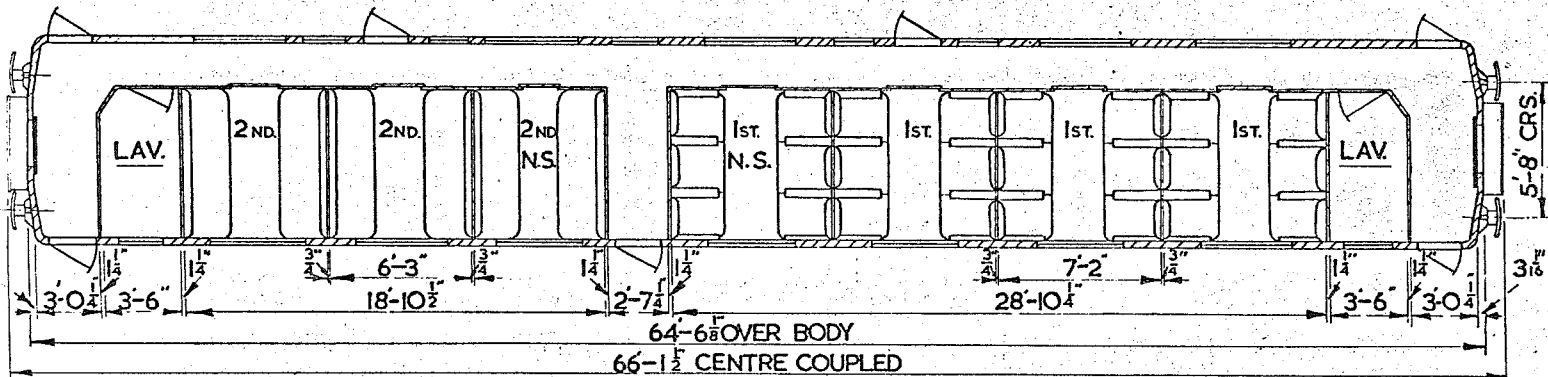
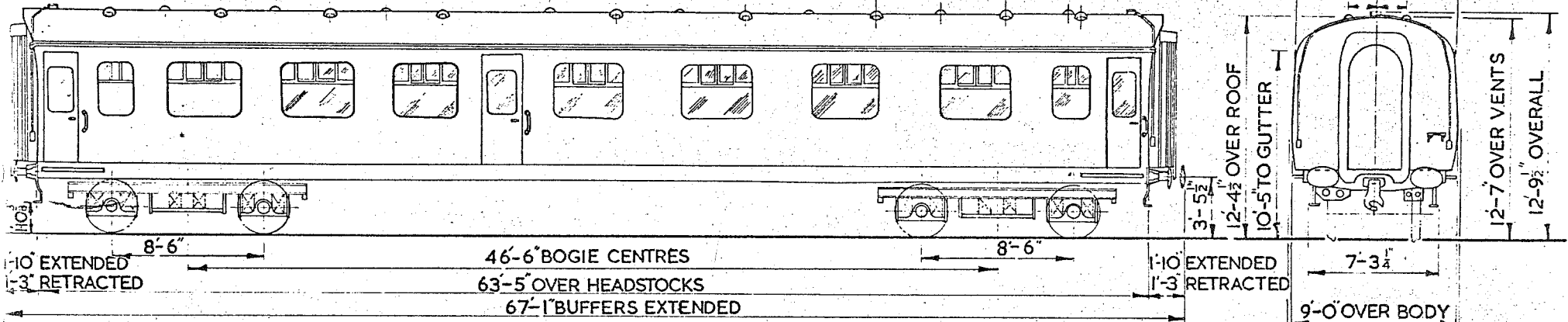

	QTY.	VEH.N ^o	LOT	BUILT AT	TARE
FIRST CLASS 24 SEATS					
SECOND CLASS 24 SEATS	10	W 59213 TO	30705	SWINDON	32 TON
2 LAVATORIES		W 5127			3 CWTs.



TRAILER SECOND I.C.D.T. B-S

BR.568

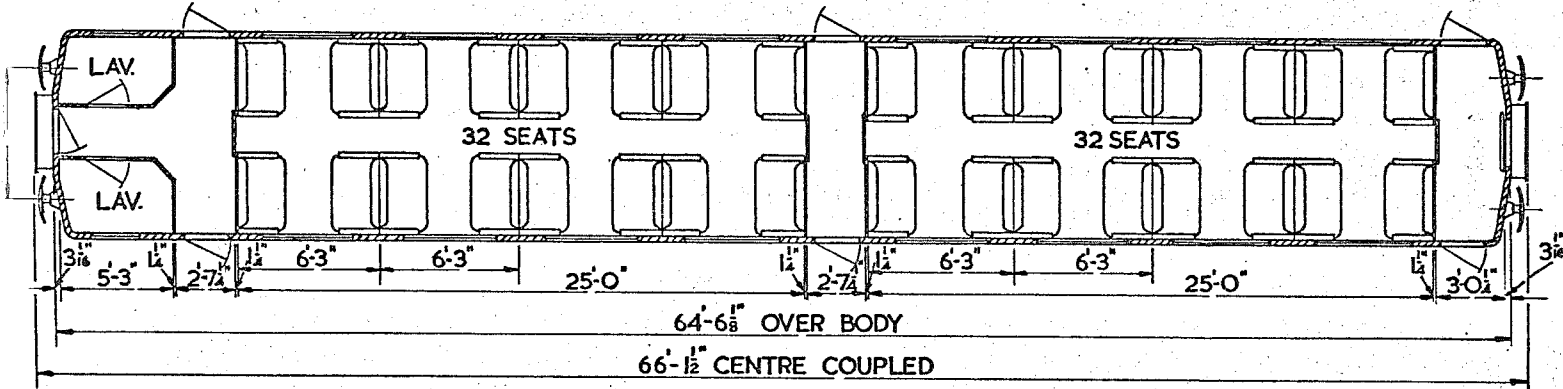
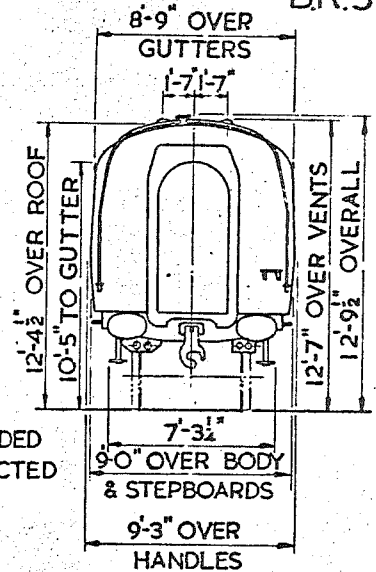
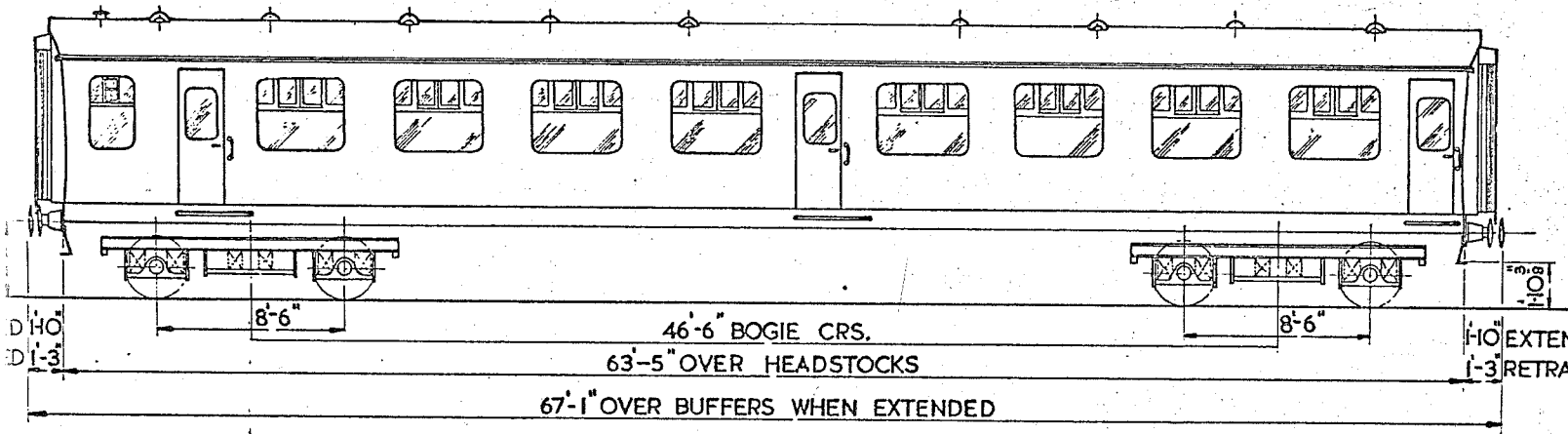

CLASS	64 SEATS	QTY.	VEH. NOS.	LOT	BUILT AT	TARE
ORIES		5	W59235 TO W59239	3 06	SWINDON	31 TONS 9CWTs



TRAILER SECOND BUFFET I-C.D.T. B-S

BR.569

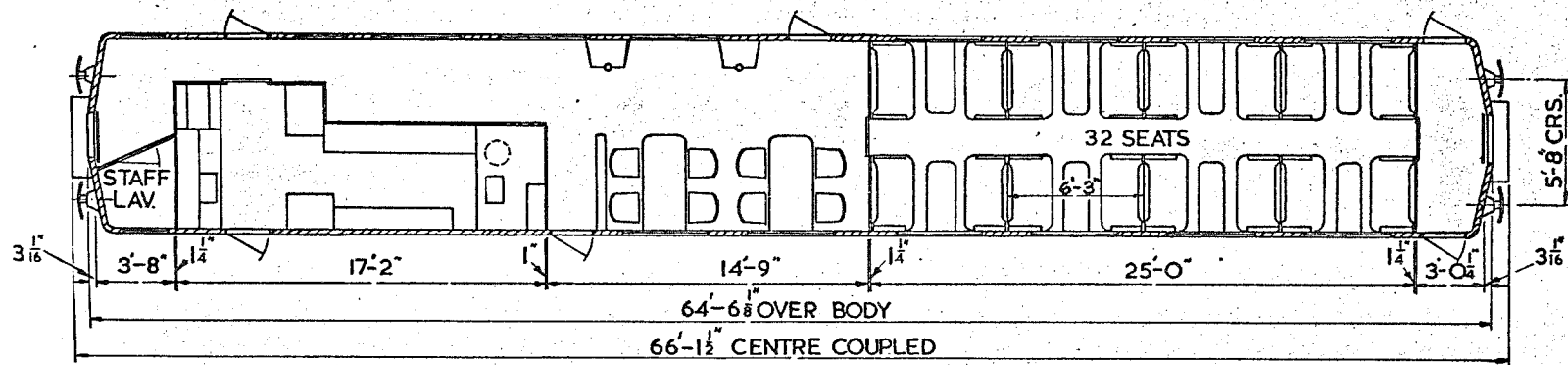
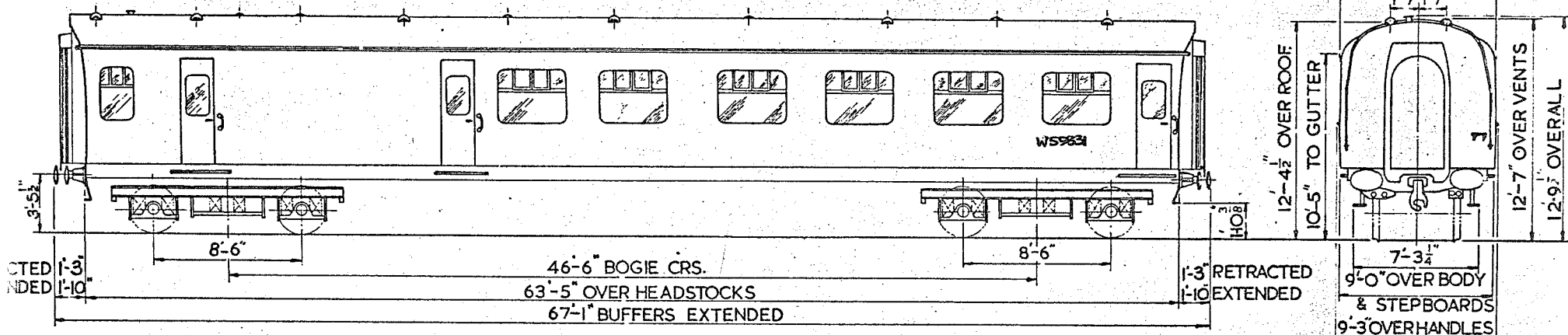

SECOND CLASS 32 SEATS
1 STAFF LAVATORY

QTY.
5

VEH. N^o W59828 W59832
LOT N^o 30707

BUILT AT
SWINDON

TARE
33 TONS 5 CWTs.



TRAILER SECOND

CROSS COUNTRY DIESEL TRAIN.

B.R. 572

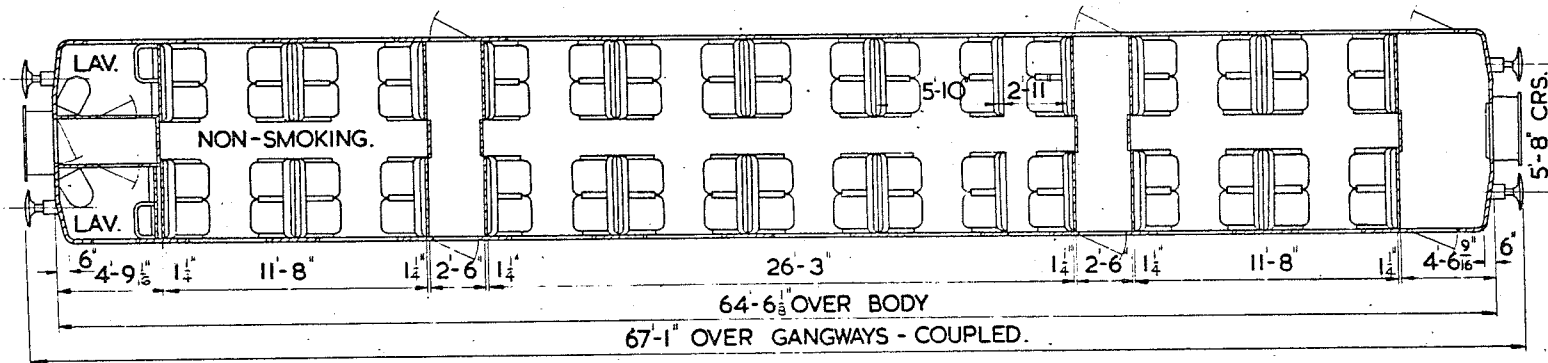
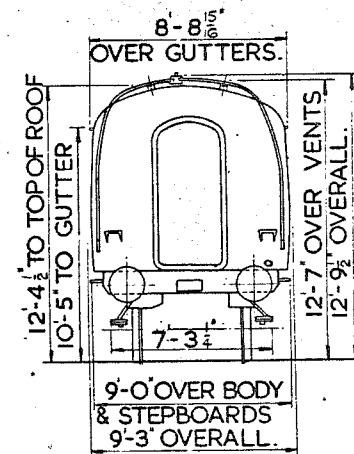
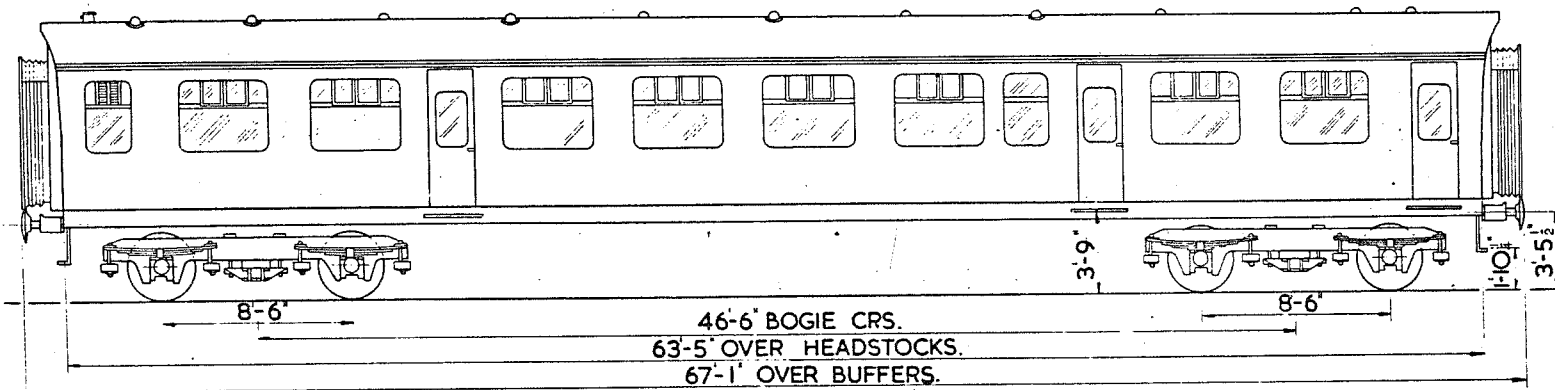

QTY.	LOT.	TONS.	CWTS.	BUILT AT
10	30517	30	3	SWINDON



SECOND CLASS - 68 SEATS.
2 LAVATORIES.

TRAILER SECOND
INTER CITIES DIESEL TRAINS

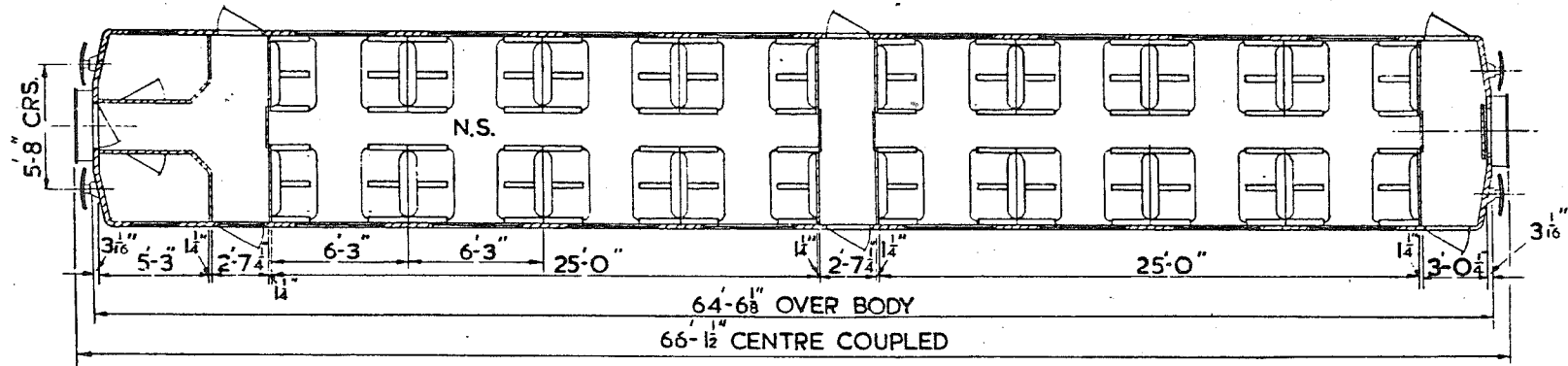
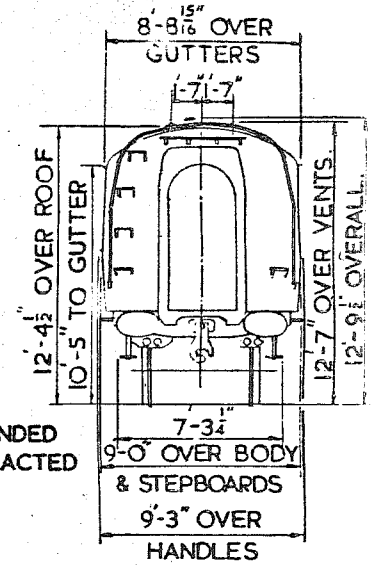
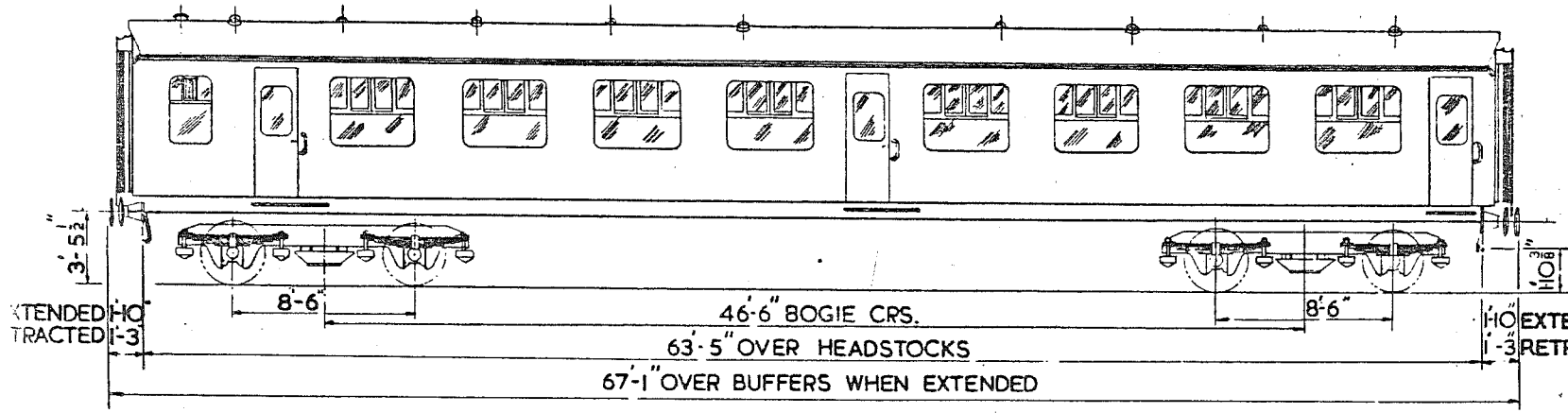

SECOND CLASS 64 SEATS LAVATORIES	QTY. 9	VEH. NOS. E.59765 to E.59773	LOT 30605	BUILT AT SWINDON	TARE 32 TONS
-------------------------------------	-----------	---------------------------------	--------------	---------------------	-----------------

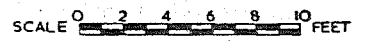

MOTOR SECOND 1-C.D.T. B-S

BR.574

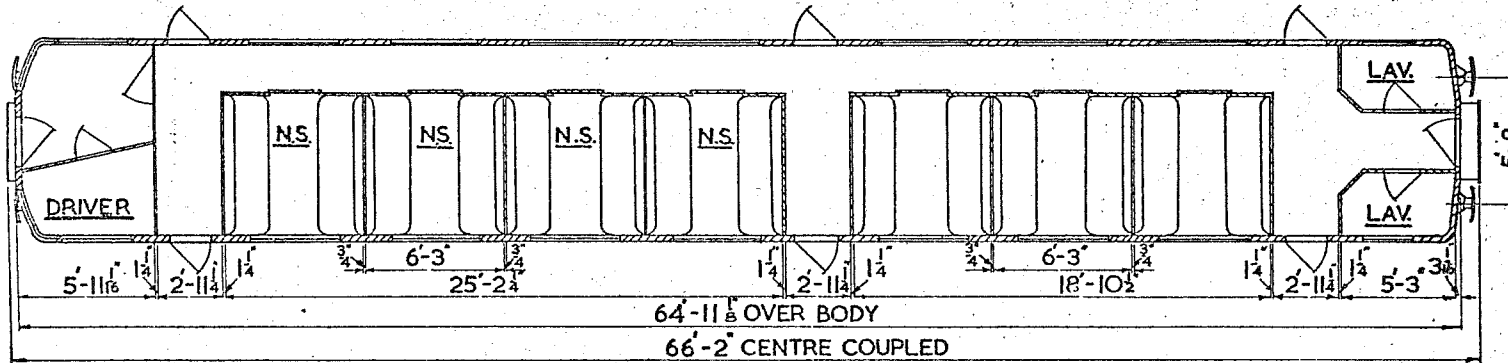
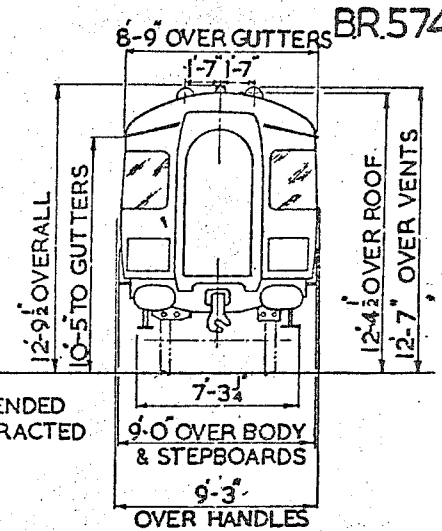
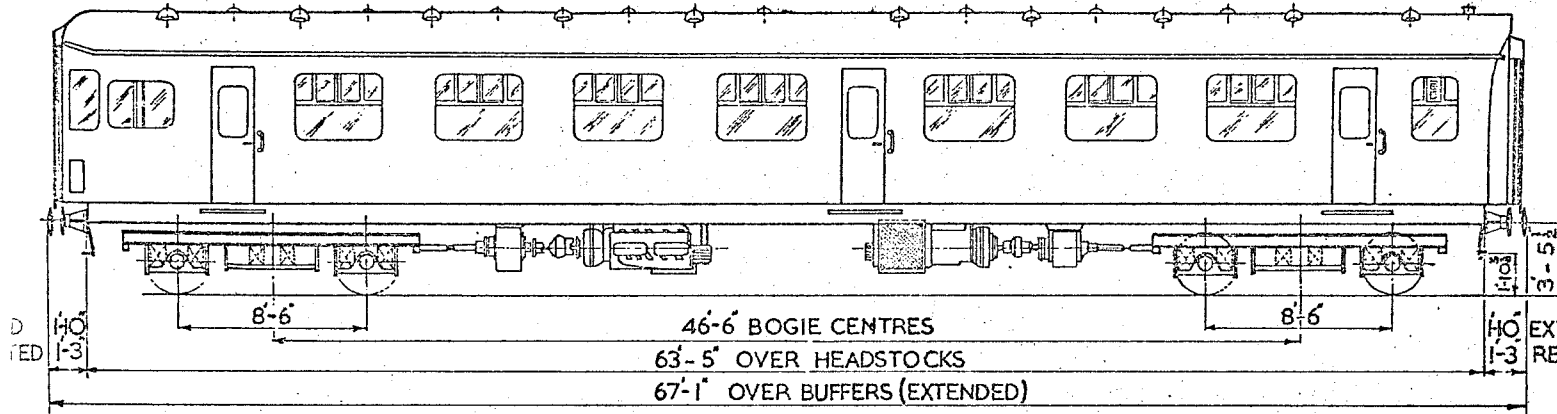

56 SECOND CLASS SEATS
TWIN LAVATORIES

QTY.
10

VEH.No.
W52096-70
W52105

LOT No.
30704

BUILT AT
SWINDON

TARE
41 TON 9 CWT

ENGINES
2 x 230 B.H.P.



MOTOR OPEN COMPOSITE.
(INTER-CITIES DIESEL TRAINS)

B.R. 577

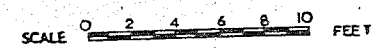
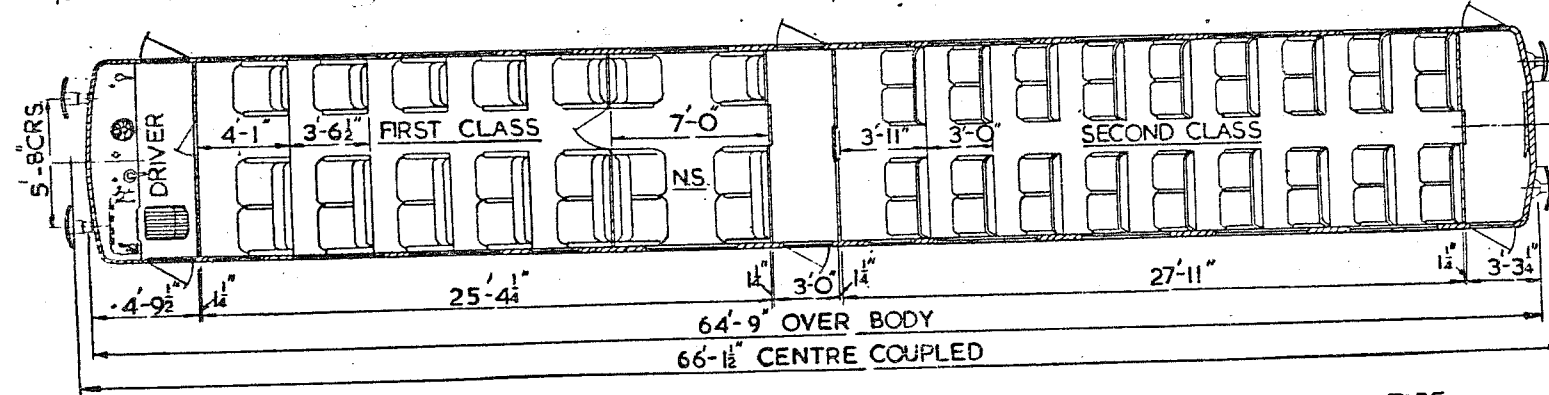
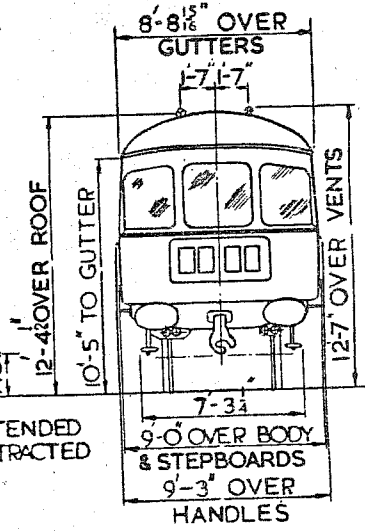
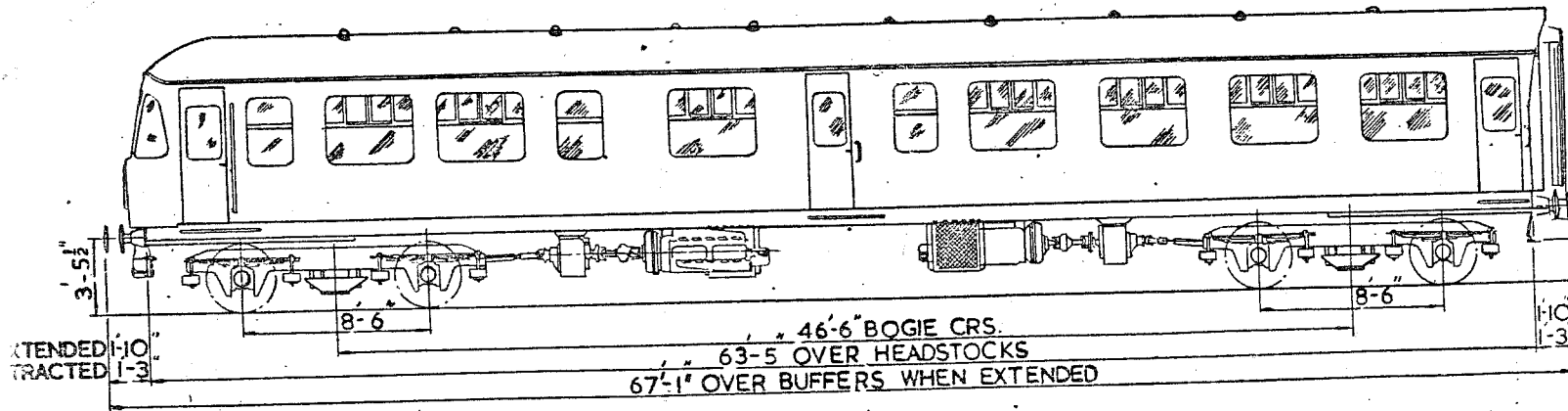

FIRST CLASS 21 SEATS
 SECOND CLASS 36 SEATS

QTY.
 17

VEH.N^{os}
 5195 to E. 51967

LOT
 30603

BUILT AT
 SWINDON

TARE
 40 TONS 0 CWTS.

ENGINES
 2x230 HP BUT

MOTOR SECOND BRAKE.
INTER CITIES DIESEL TRAIN.

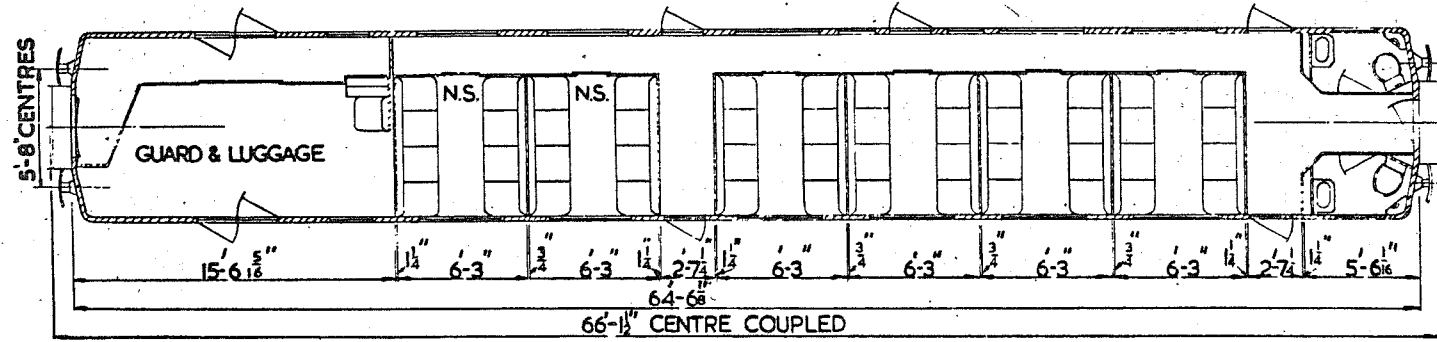
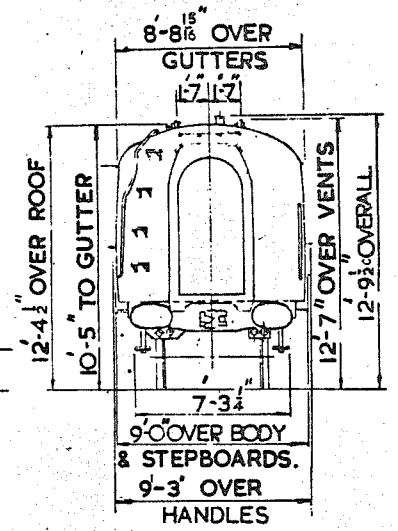
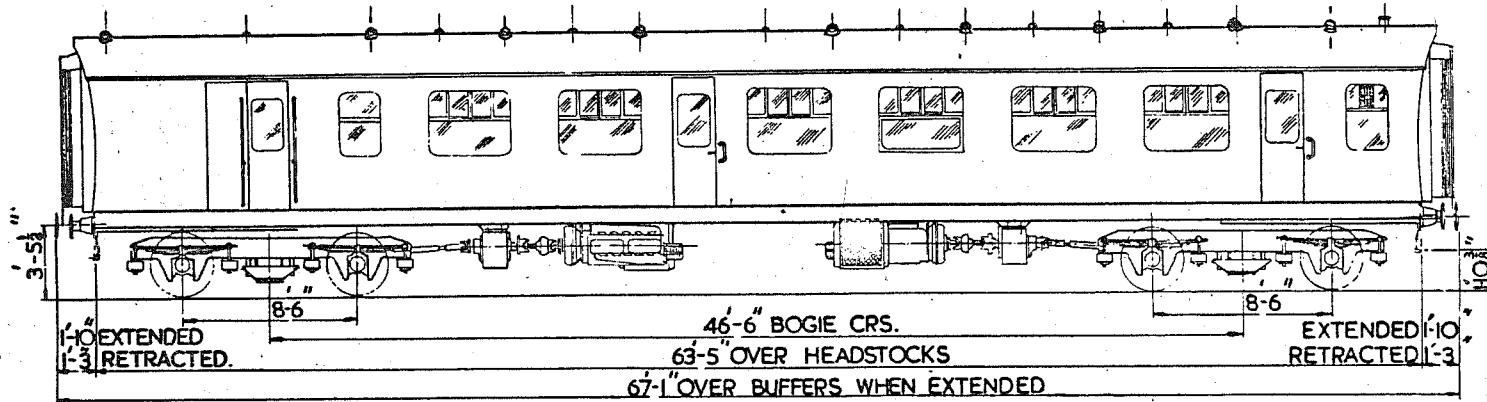

SECOND CLASS 48 SEATS
1 GUARD & LUGGAGE COMP 1
2 LAVATORIES

QTY
17

VEH N°
E5968 - E5984

LOT
30604

BUILT AT
SWINDON

TARE
41 TONS 0 CWTs

ENGINES
2x230 HP BUT

GANGWAYED MOTOR OPEN COMPOSITE LAVATORY.

B.R. 580.

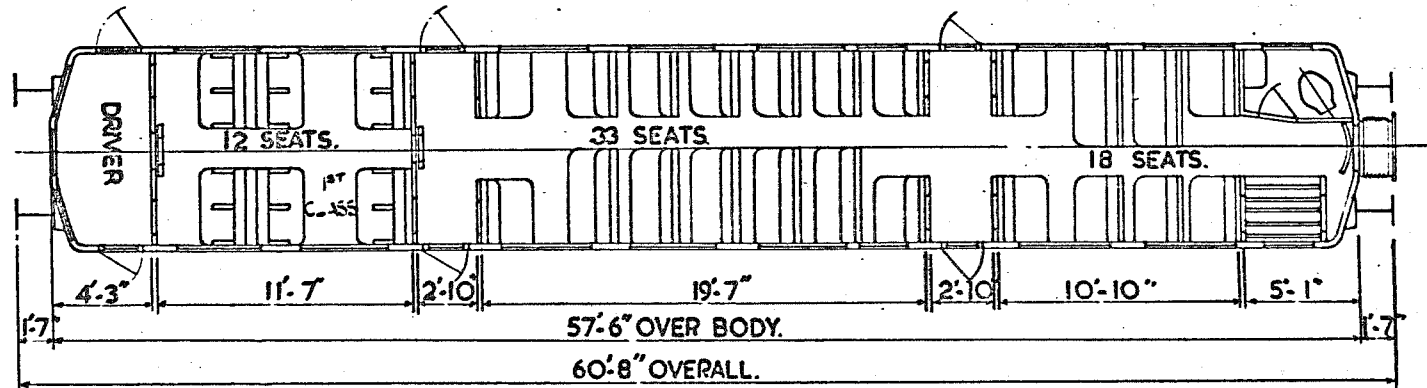
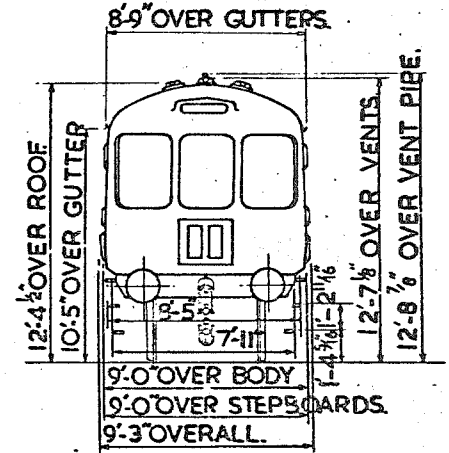
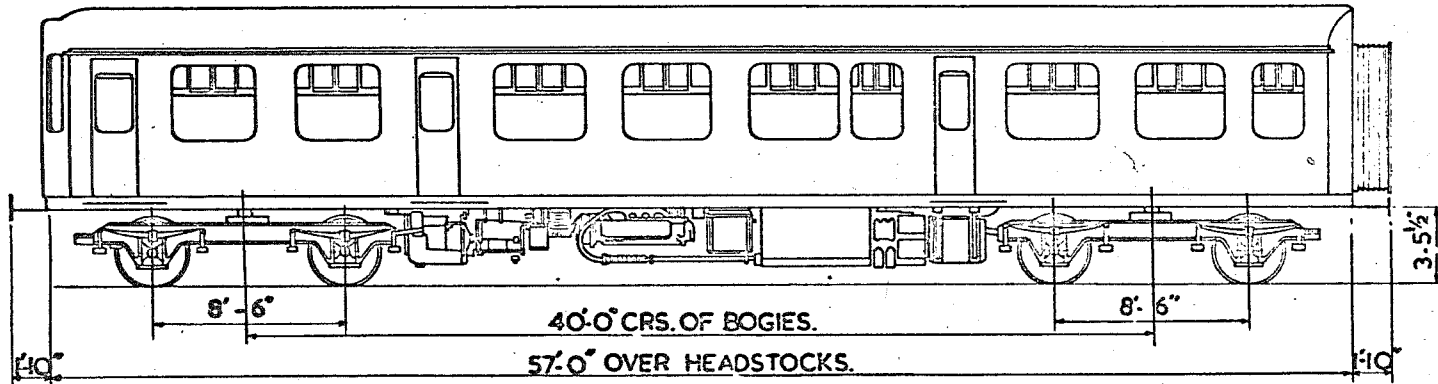

- 1 FIRST. 12 SEATS.
- 2 SECOND. 51 SEATS.
- 1 DRIVING COMPARTMENT.
- 1 LAVATORY

2x150 H.P. B.U.T. ENGINES.

LOT No.
30298
30301

VEHICLE Nos.
E 50542 - E 50562
O 50584 - E 50588

BUILT AT
BIRMINGHAM RLY. C.&W.Co.

TARE
31 T.

GANGWAYED DRIVING TRAILER OPEN COMPOSITE LAVATORY.

B.R. 581.

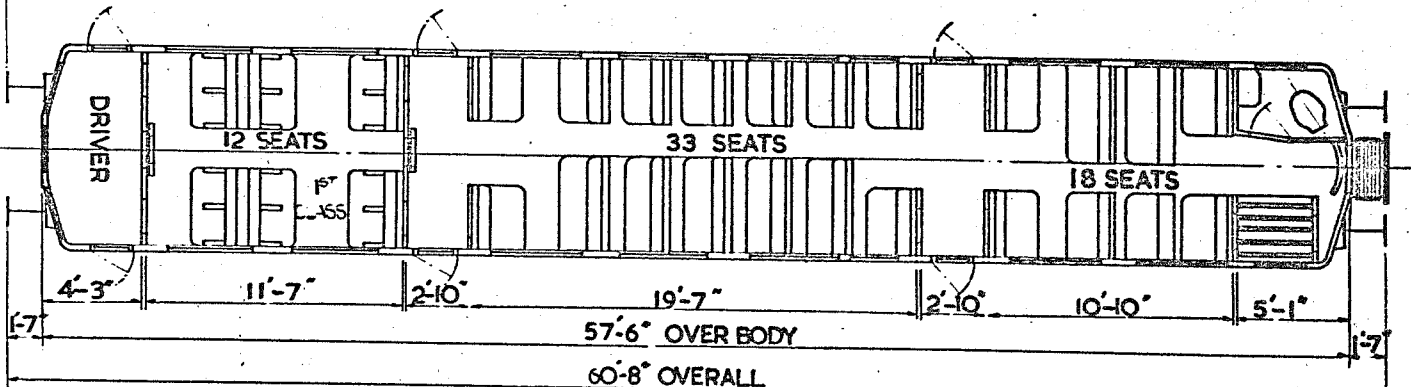
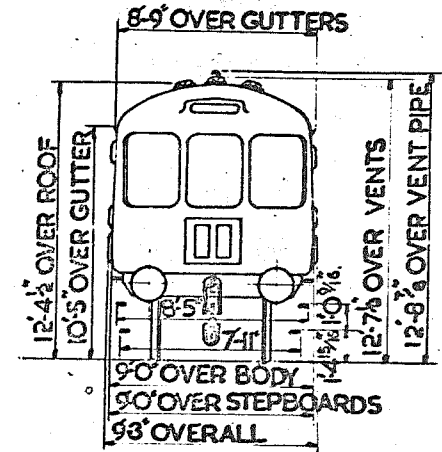
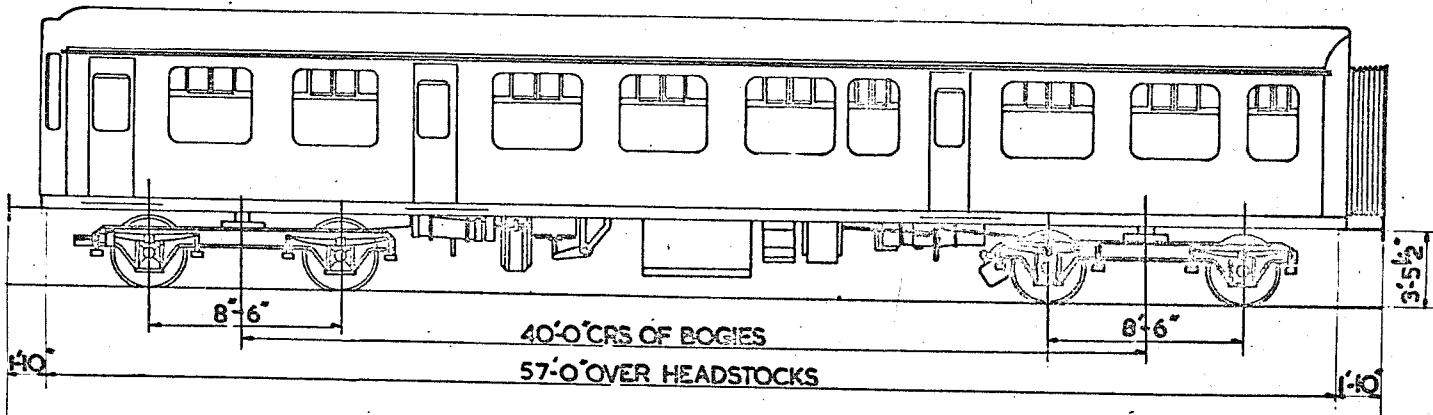

- 1 FIRST. 12 SEATS.
- 2 SECOND. 51 SEATS.
- 1 DRIVING COMPARTMENT.
- 1 LAVATORY.

LOT No.
30405

VEHICLE Nos.
E 56185 - E56189

BUILT AT
BIRMINGHAM RLY. C.&W. Co.

TARE
24 T.

GANGWAYED TRAILER OPEN COMPOSITE LAVATORY.

B.R. 582.

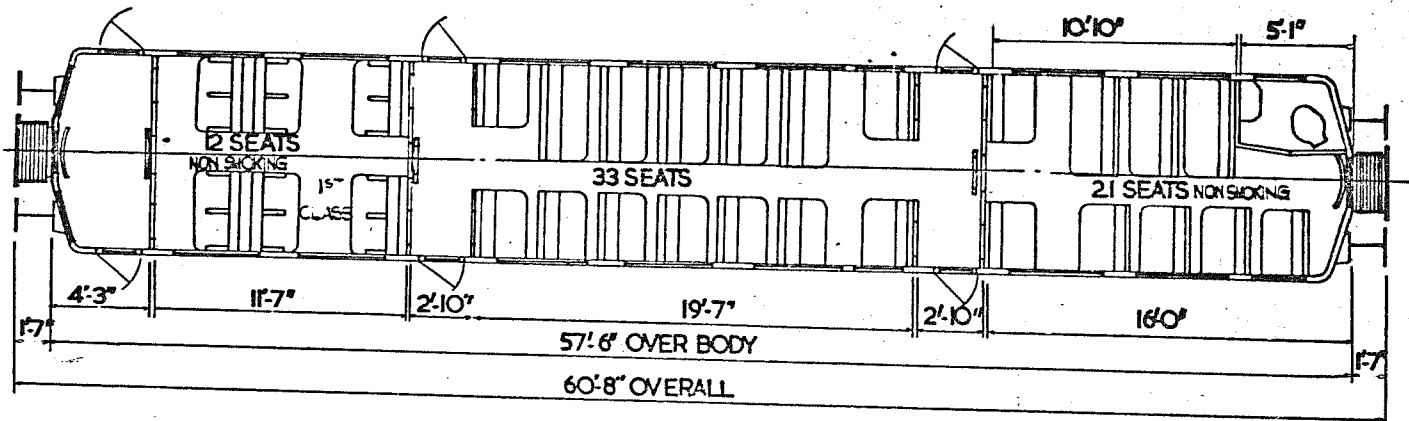
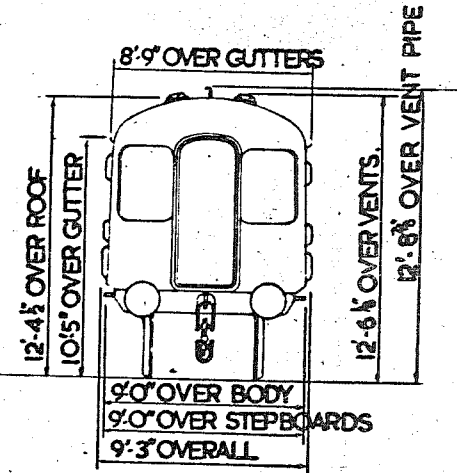
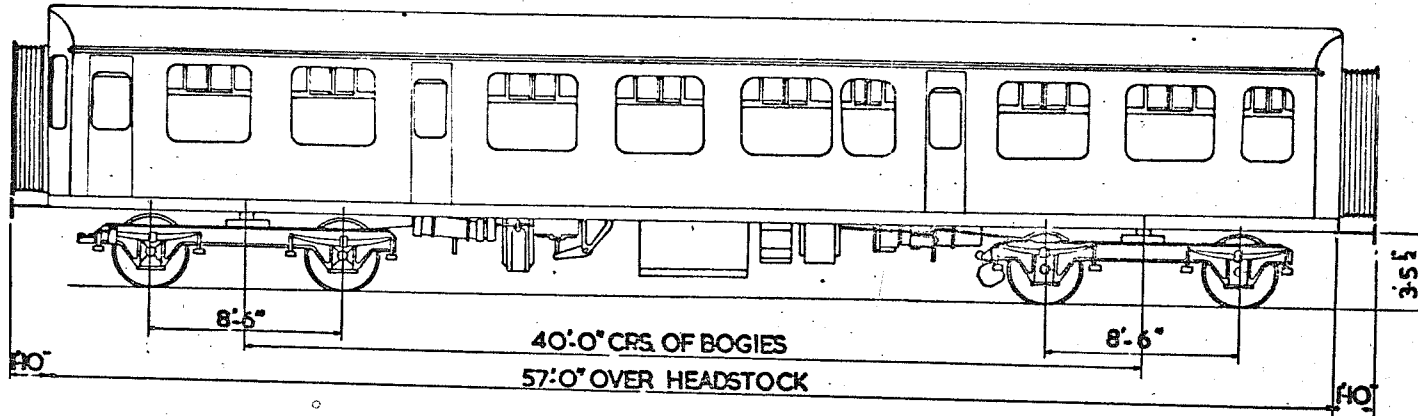

1 FIRST. 12 SEATS.
2 SECOND. 54 SEATS.
1 LAVATORY.

LOT No.
30292.
30295.

VEHICLE Nos.
M 59132-M 59135.
M 59136-M 59187.

BUILT AT
BIRMINGHAM RLY. C.&W. Co.

TARE
24 T.

GANGWAYED TRAILER OPEN SECOND LAVATORY.

B.R. 583.

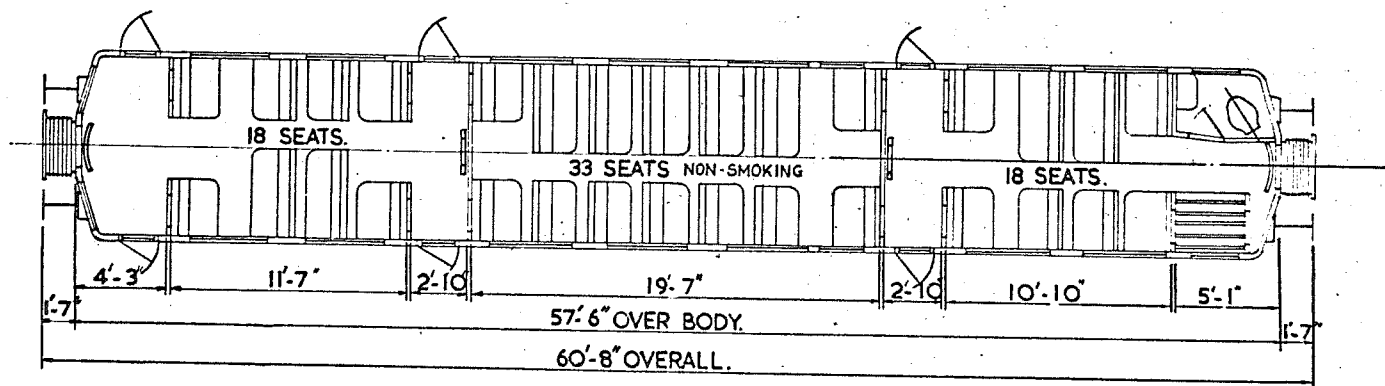
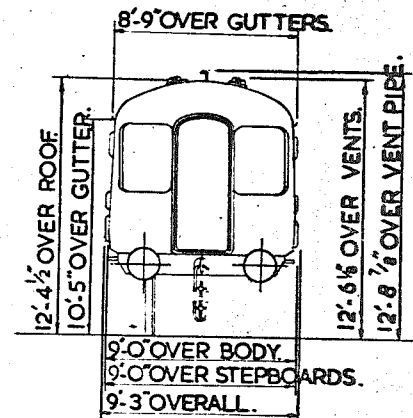
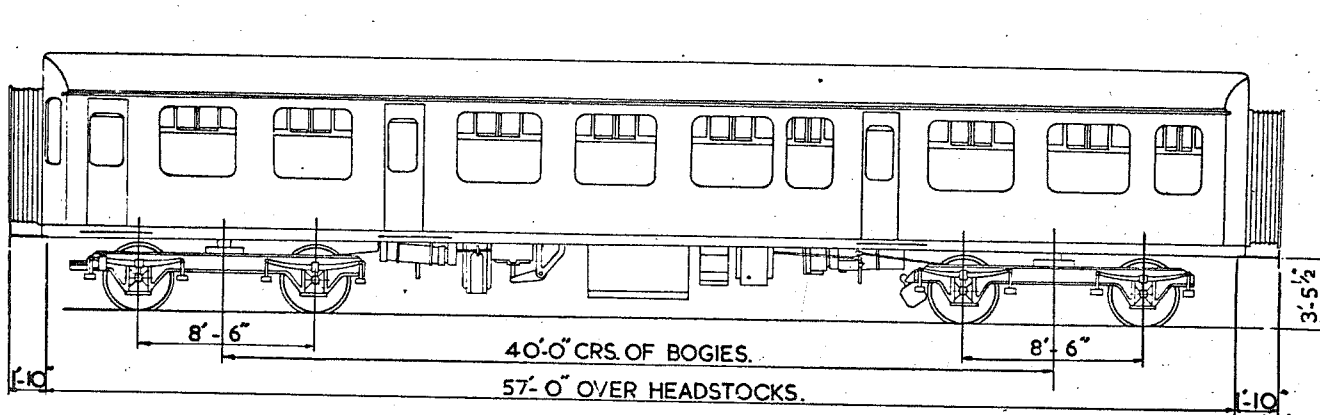

3 SECOND. 69 SEATS.
1 LAVATORY.

LOT No
30299
30302

VEHICLE Nos.
E 5009-E 59208.
E 5000-E 59234.

BUILT AT
BIRMINGHAM RLY. C&W. Co.

TARE
24 T.

GANGWAYED TRAILER OPEN SECOND BRAKE LAVATORY.

B.R. 584.

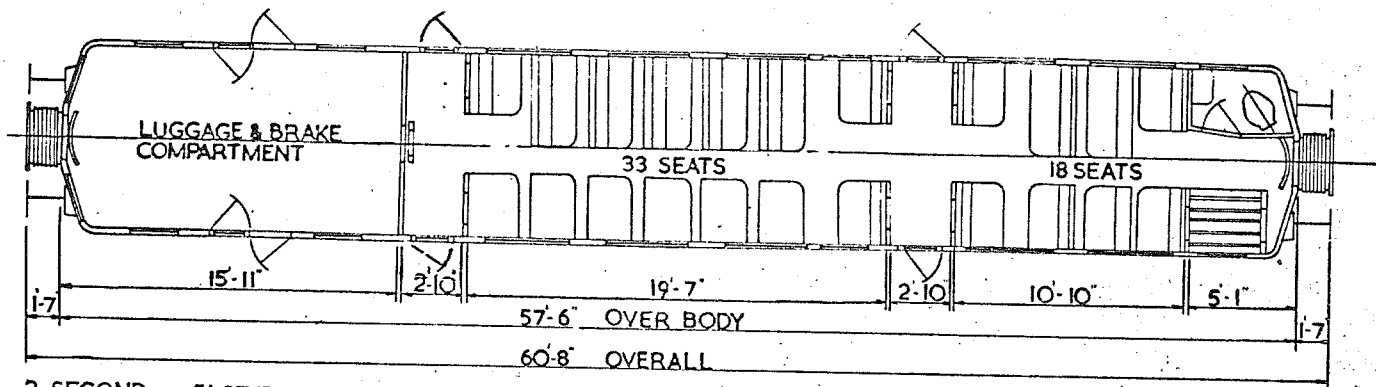
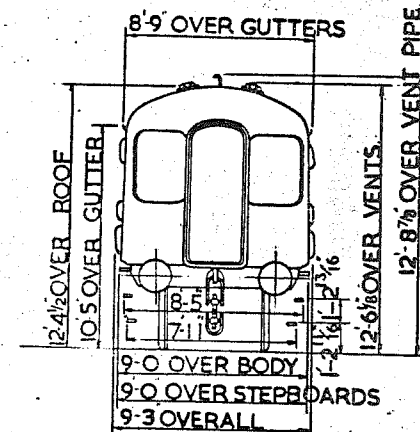
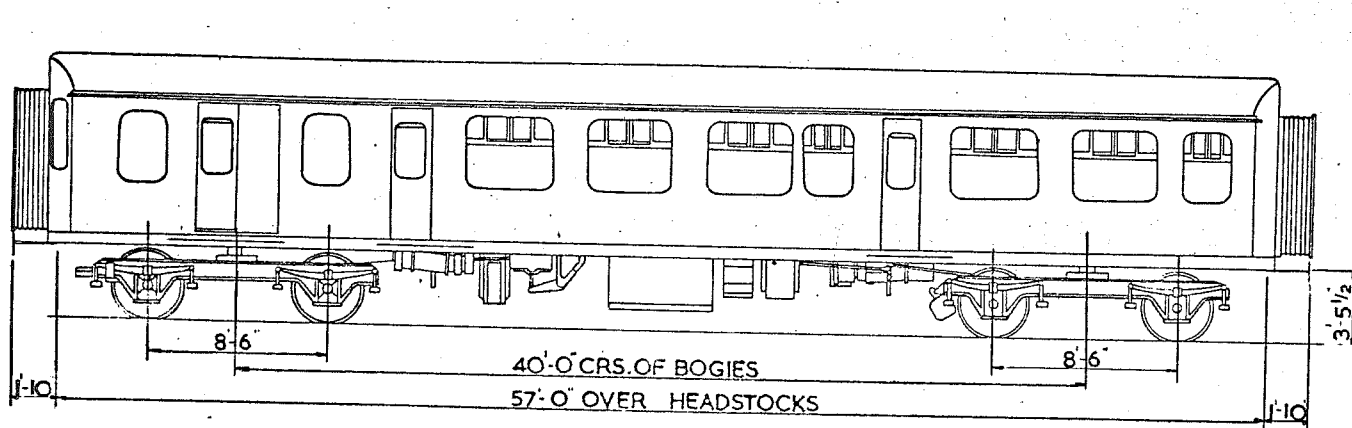

2 SECOND 51 SEATS.
1 GUARDS COMPARTMENT
1 LAVATORY.

LOT No.
30300
30303

VEHICLE Nos.
E 59209 - E 59229
E 59240 - E 59244

BUILT AT
BIRMINGHAM RLY. C.&W. Co.

TARE
25 T.

GANGWAYED DRIVING TRAILER OPEN COMPOSITE LAVATORY.

B.R. 585.

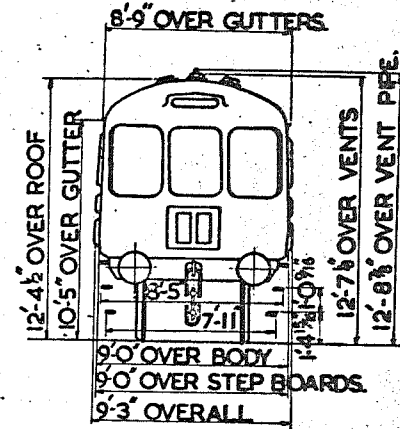
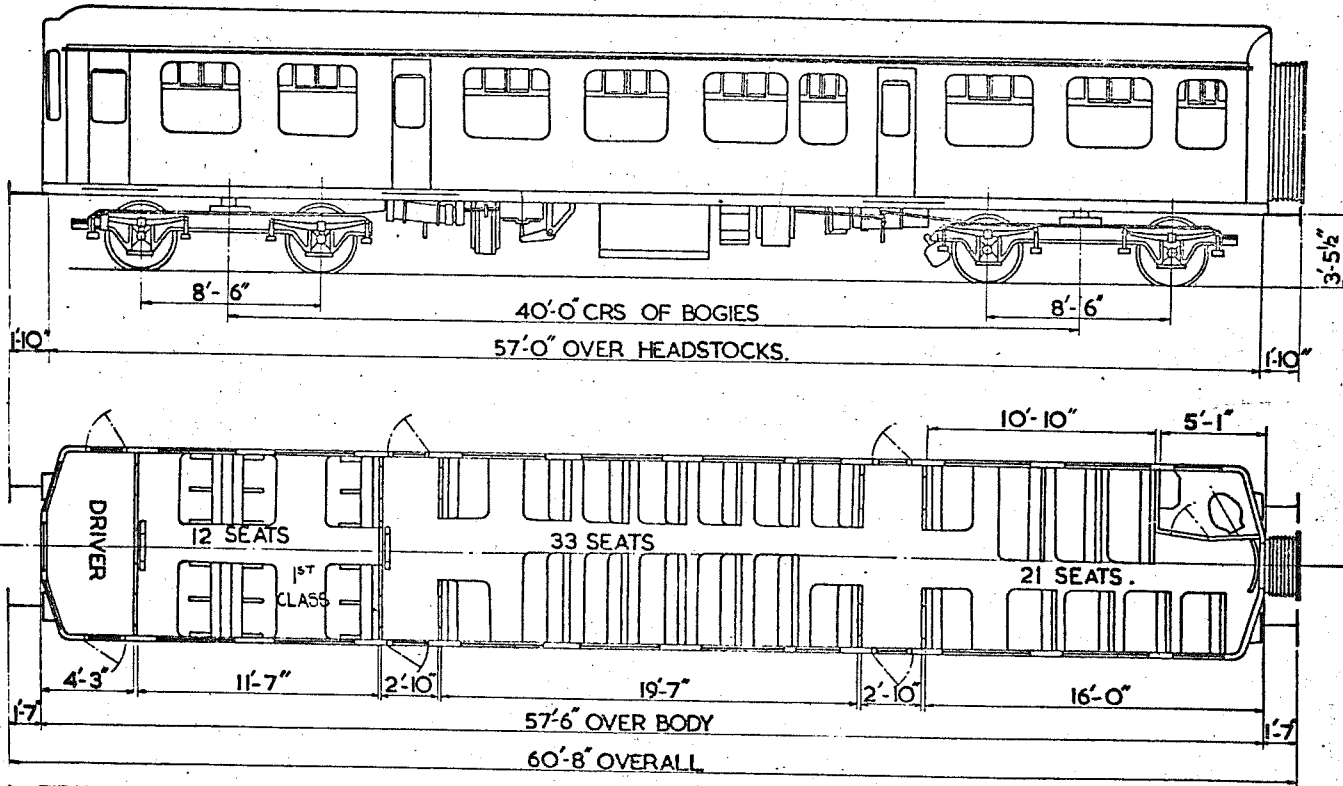

- 1 FIRST 12 SEATS.
- 2 SECOND 54 SEATS.
- 1 DRIVING COMPARTMENT.

LOT No.
30297

VEHICLE Nos.
156175 - M56184

BUILT AT
BIRMINGHAM RLY. C&W. Co.

TARE
24 T.

MOTOR SECOND
CROSS COUNTRY DIESEL TRAIN

BR. 586

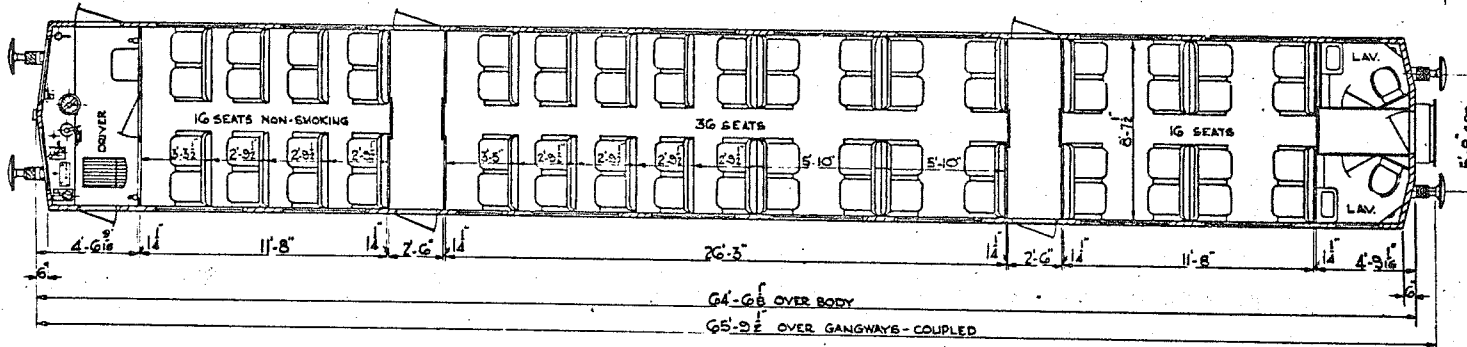
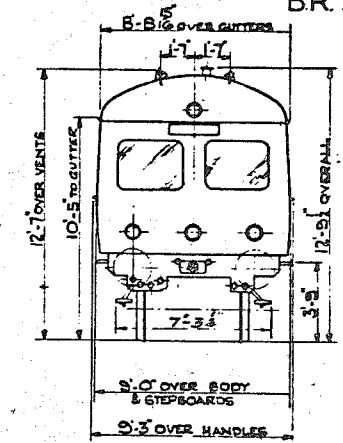
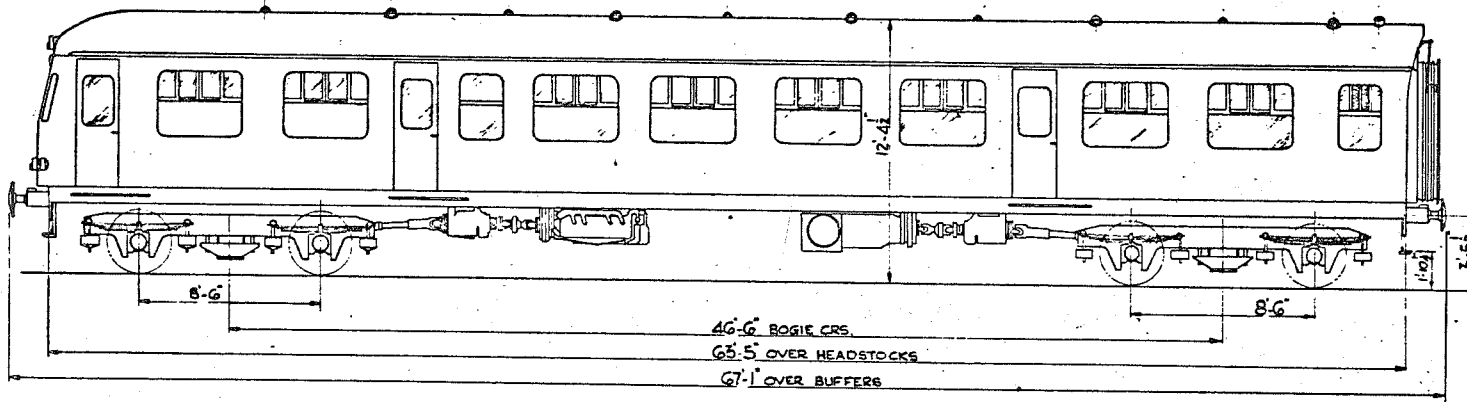

QTY.	LOT	TARE TONS. CWTs.	BUILT AT
49	30334	36 - 10	SWINDON

SECOND CLASS:- 68 SEATS
2 LAVATORIES 1 DRIVING COMP.



MOTOR BRAKE COMPOSITE
CROSS COUNTRY DIESEL TRAIN

B.R. 587

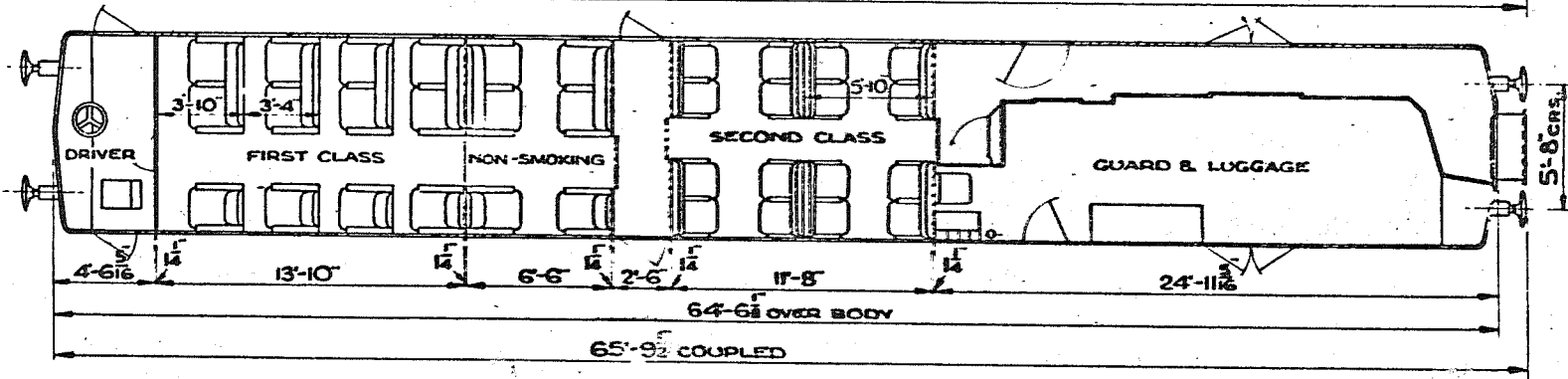
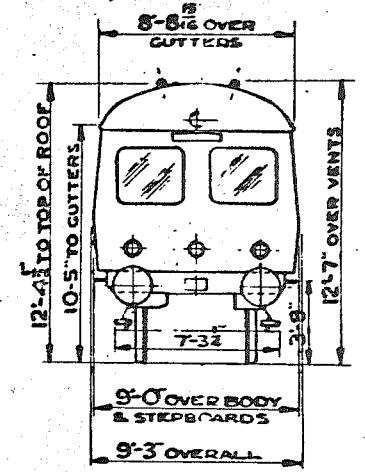
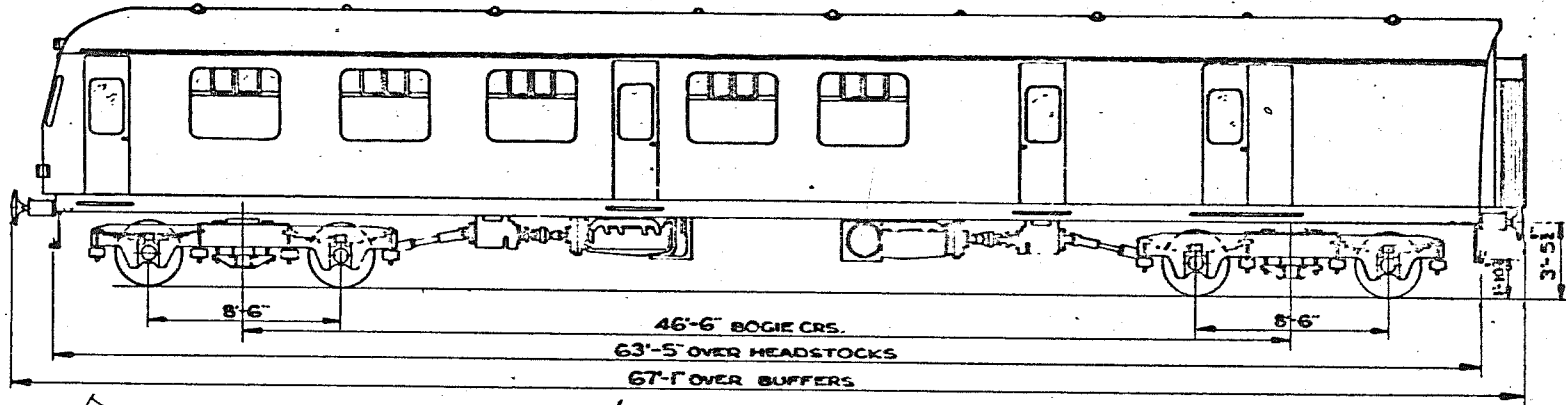

QTY.	LOT.	TARE TONS.	CWTS.	BUILT AT
49	30335	36	-	SWINDON

2 FIRST-18 SEATS. 1 SECOND 3 SEATS. 2 x 150 H.P. T. ENGINES.
 1 DRIVING COMPT. 1 GUARD & LUGGAGE COMPT.



NON GANGWAYED MOTOR SEMI - OPEN SECOND BRAKE

B.R. 588

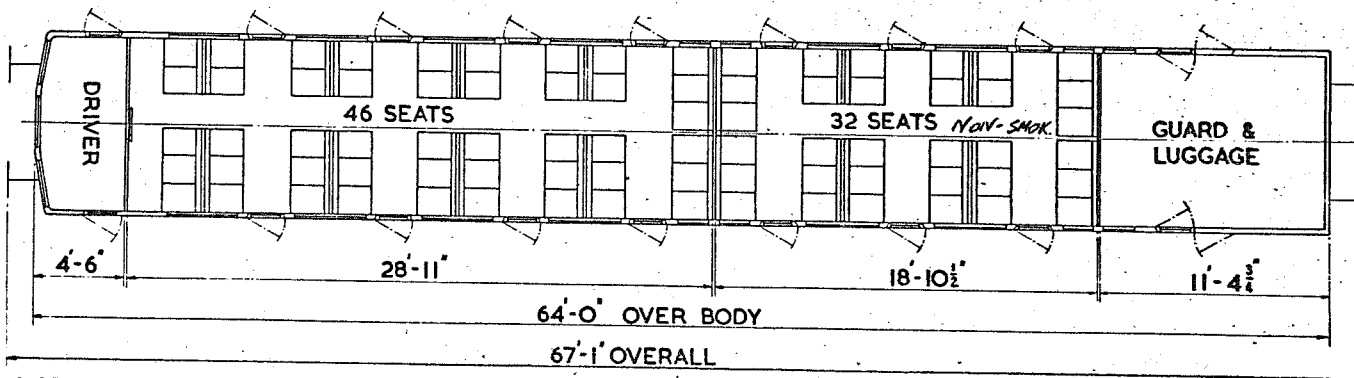
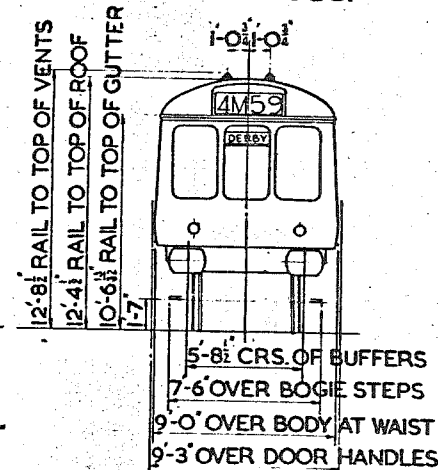
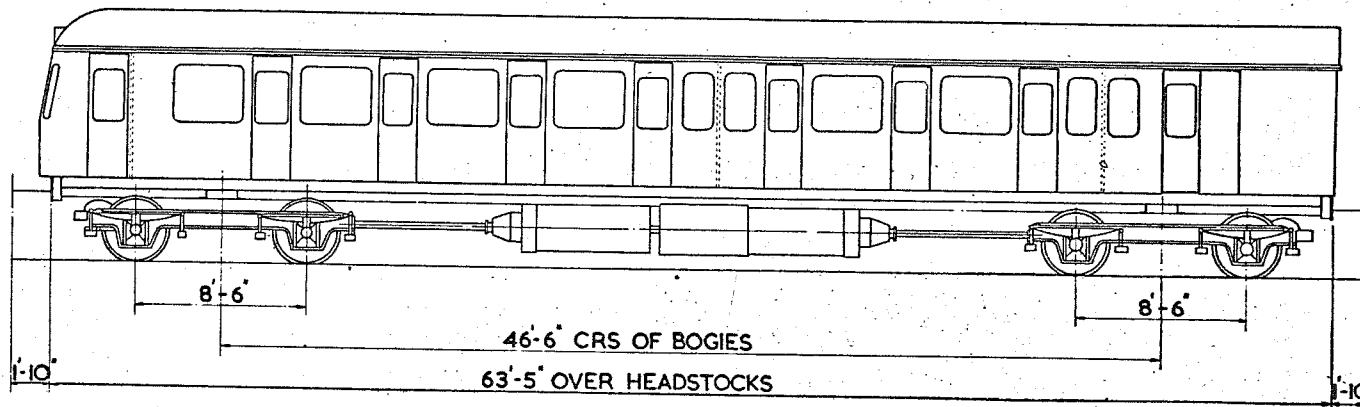

2 SECOND. 78 SEATS
1 DRIVING COMPARTMENT
1 GUARD & LUGGAGE

2 8 H.P., R.R. ENGINES

LOT No
30521

HICLE Nos
M 51591 - M51650

BUILT AT
DERBY

TARE
40 T.

NON GANGWAYED OPEN TRAILER LAVATORY SECOND.

B.R. 589.

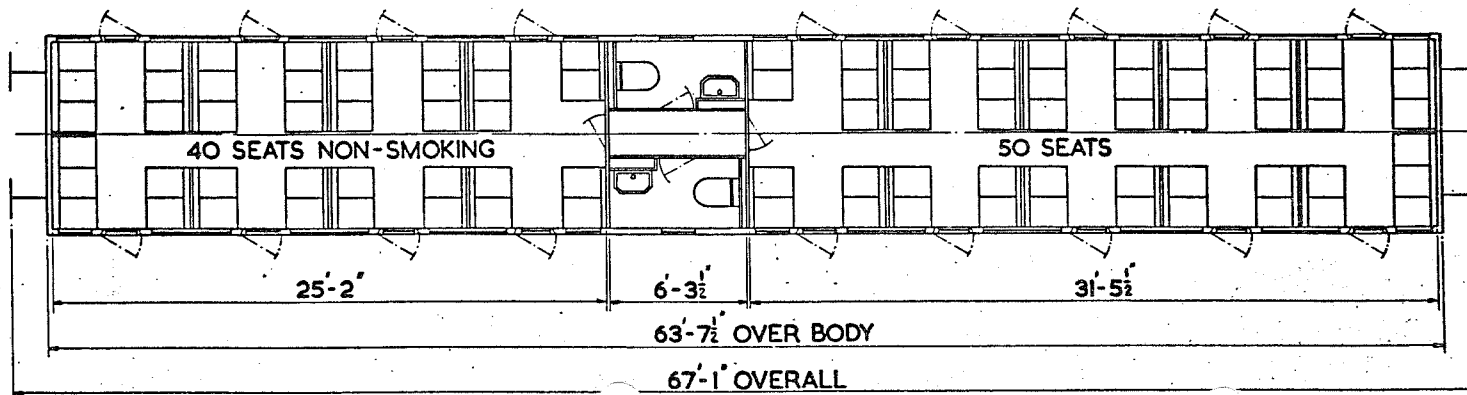
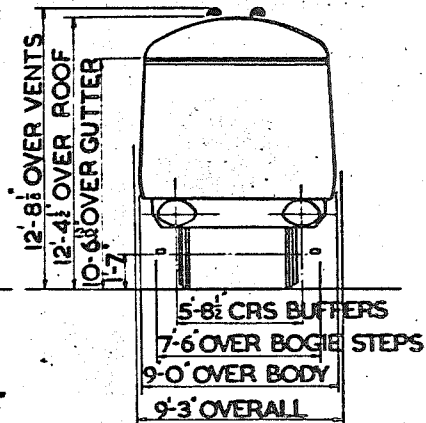
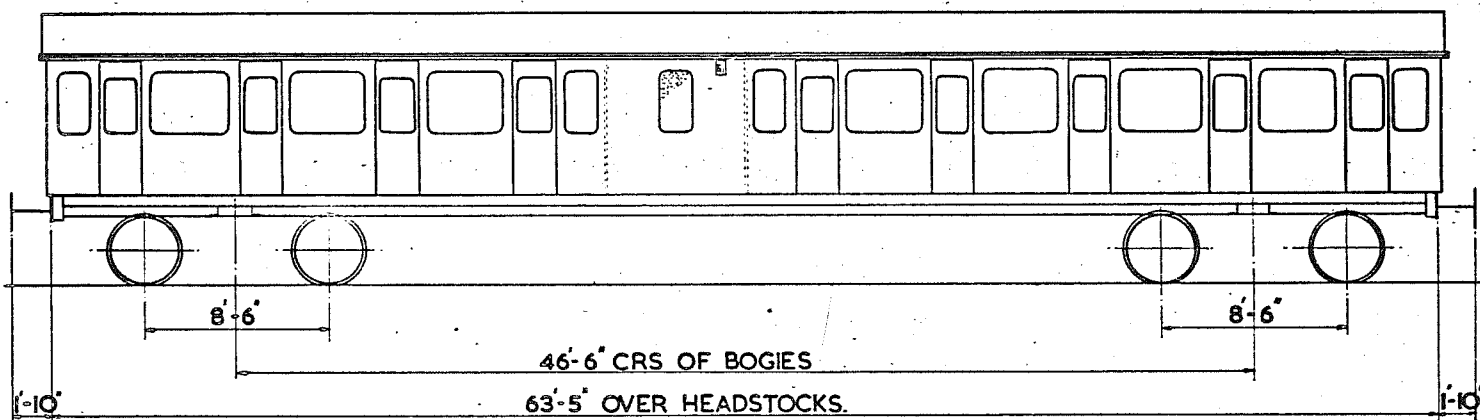

2 SECOND. 90 SEATS
 2 LAVATORIES

LOT No
 30522

VEHICLE No
 M59589 - M59618

BUILT AT
 DERBY

TARE
 30 T

NON GANGWAYED SEMI-OPEN TRAILER SECOND

B.R. 590

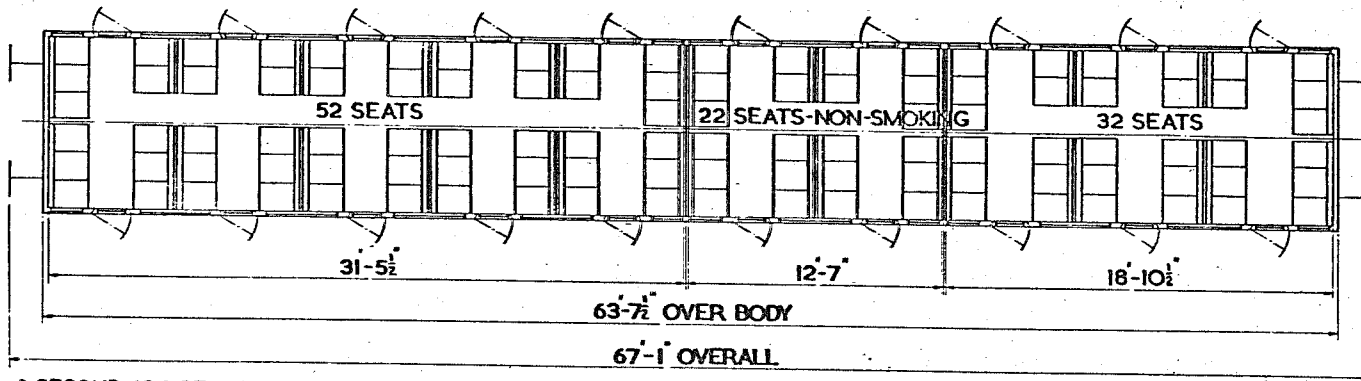
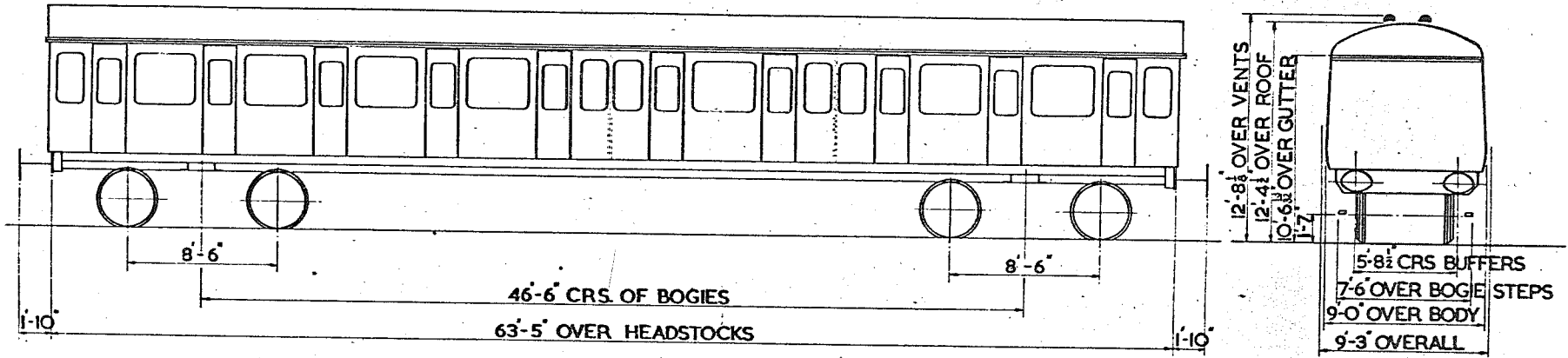

3 SECOND 106 SEATS

LOT No	VEHICLE Nos
30523	M59619 - M59648
30531	M59649 - M59663
30596	M59713 - M59718
30599	M59725 - M59744

BUILT AT	TARE
DERBY	29 T
DERBY	29 T
DERBY	29 T
DERBY	29 T

GANGWAYED MOTOR OPEN SECOND BRAKE

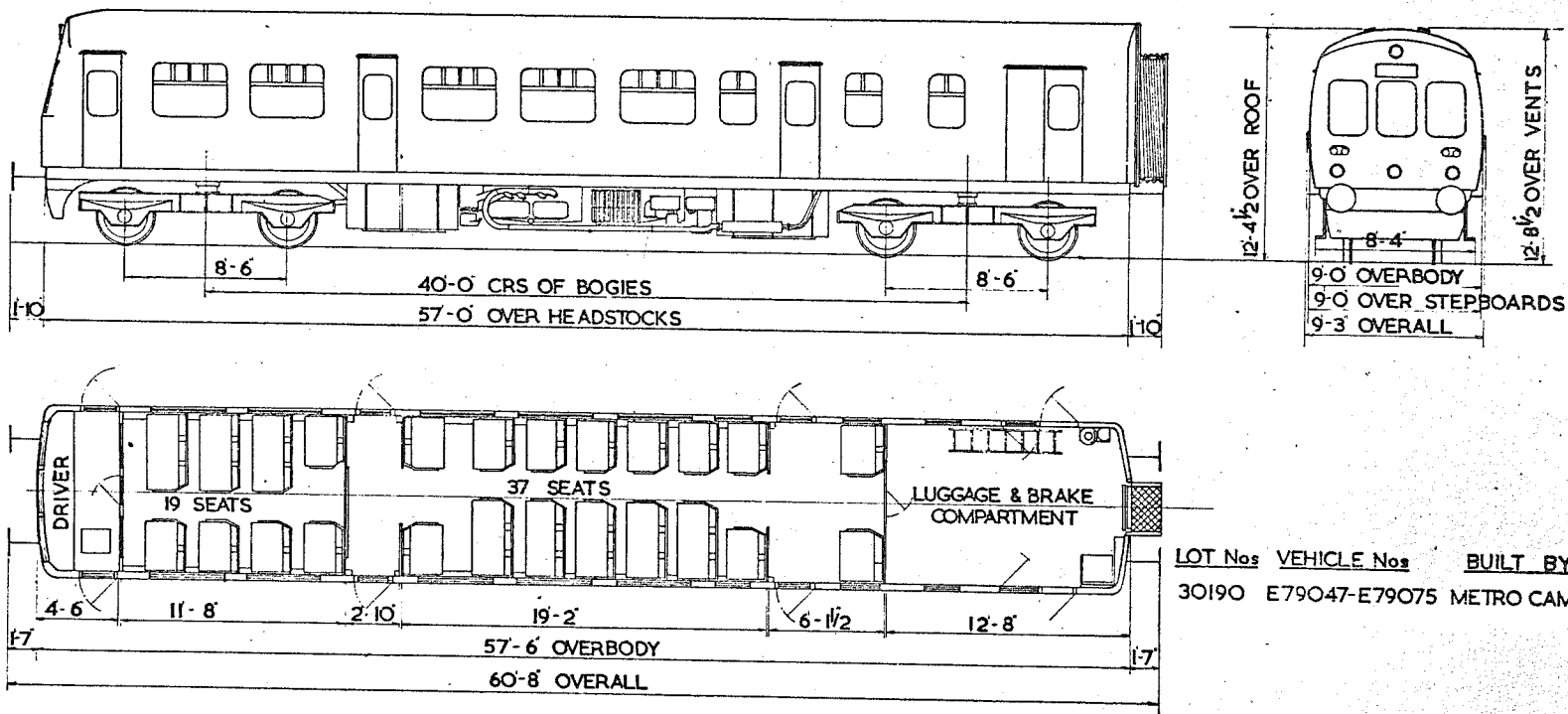

LOT Nos	VEHICLE Nos	BUILT BY	TARE
30190	E79047-E79075	METRO CAMMELL	3 1/2 T

- 2 - SECOND 56 SEATS.
- 1 - DRIVERS COMPARTMENT.
- 1 - LUGGAGE COMPARTMENT.

2 x 150 HP. BUT. ENGINES

GANGWAYED MOTOR OPEN SECOND BRAKE

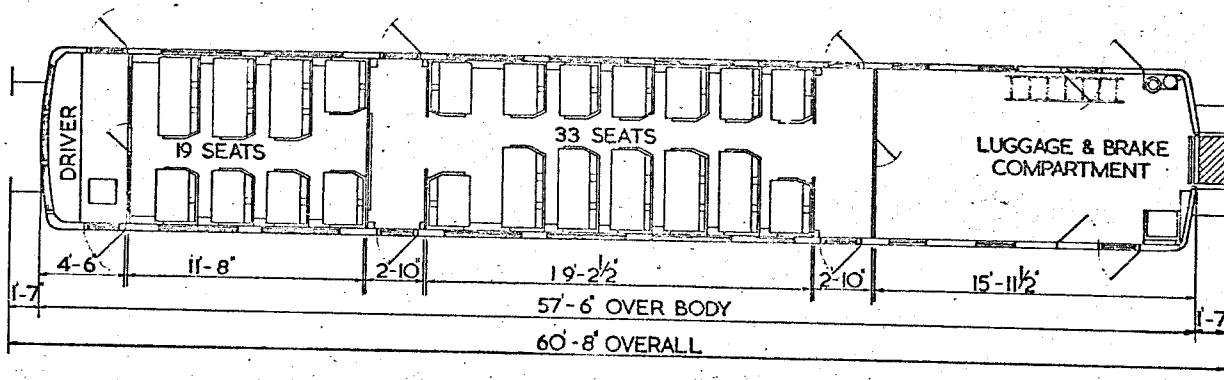
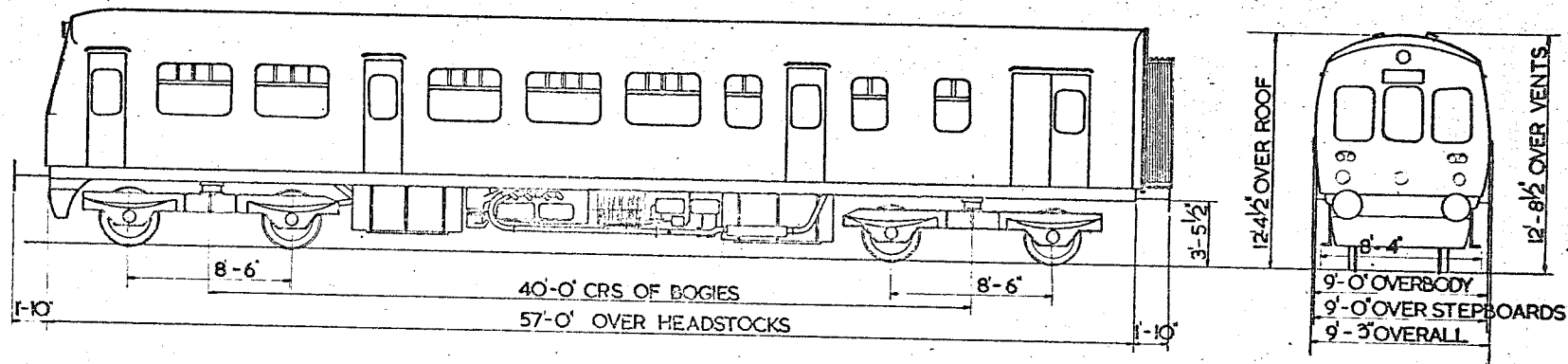

LOT Nos	VEHICLE Nos	BUILT AT	TARE
30190	M79076 - M79082	METRO CAMMELL	3 1/2 T

- 2-SECOND 52 SEATS
- 1-DRIVERS COMPARTMENT
- 1-LUGGAGE COMPARTMENT

2 x 150 HP RUIT ENGINES

GANGWAYED DRIVING TRAILER OPEN SECOND LAVATORY

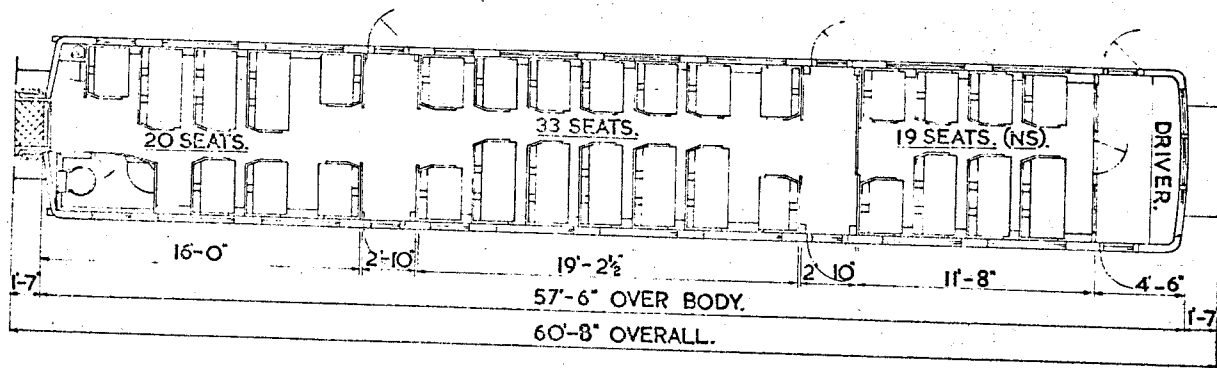
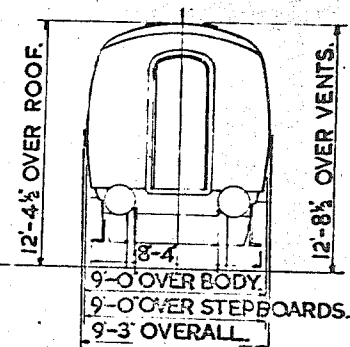
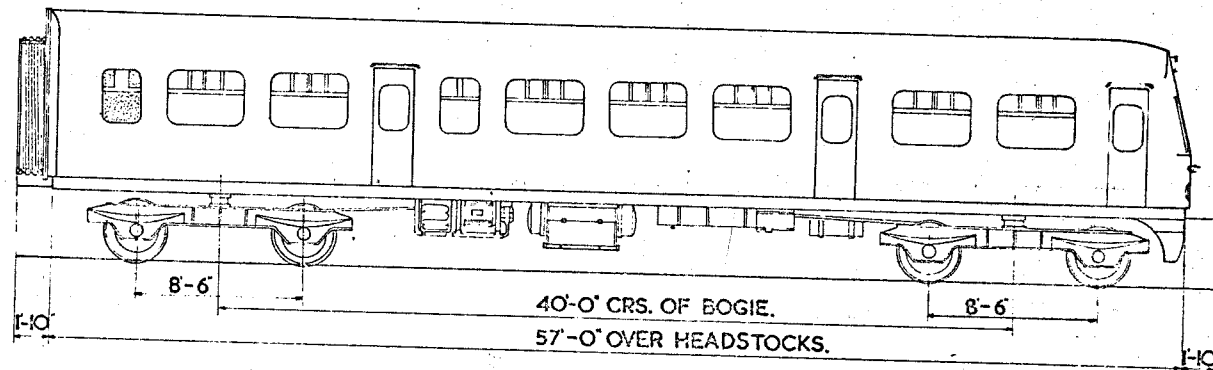

LOT Nos	VEHICLE Nos	BUILT BY	TARE
30191	E79263-E79291	METRO CAMELL	25T

3-SECOND 72 SEATS
 1-DRIVER'S COMPARTMENT
 1-LAVATORY

NS.-NON-SMOKING

Original © BRB Residuary Ltd

Original diagrams courtesy of Clive Mortimore. This PDF copy by J.D. Faulkner, 2010
 (visit <http://www.barrowmoremrg.co.uk>)

GANGWAYED DRIVING TRAILER OPEN COMPOSITE LAVATORY

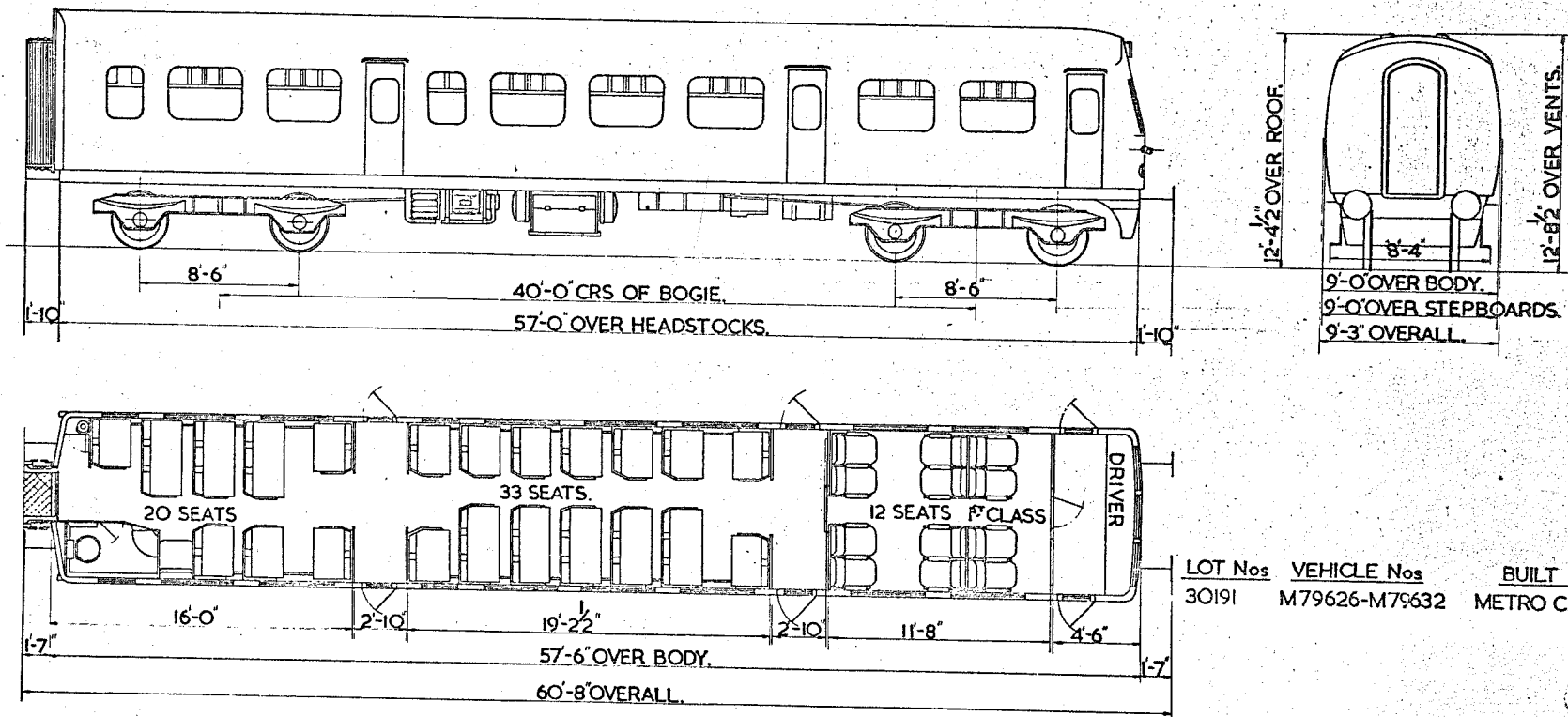

LOT Nos	VEHICLE Nos	BUILT BY	TARE
30191	M79626-M79632	METRO CAMELL	25T

- 1 - FIRST 12 SEATS
- 2 - SECOND 53 SEATS
- 1 - DRIVERS COMPARTMENT

NON GANGWAYED MOTOR OPEN SECOND BRAKE.

B.R. 595

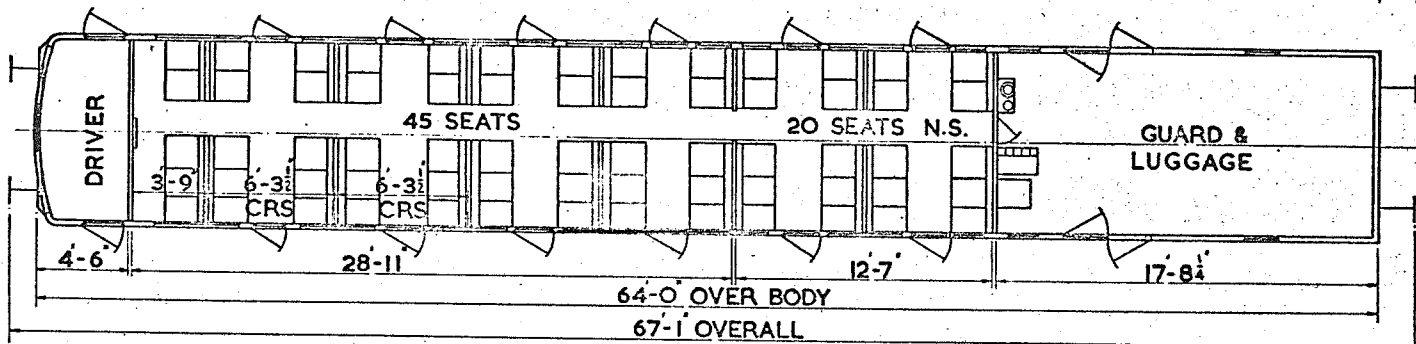
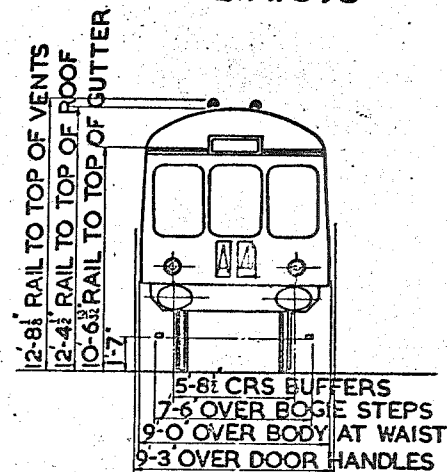
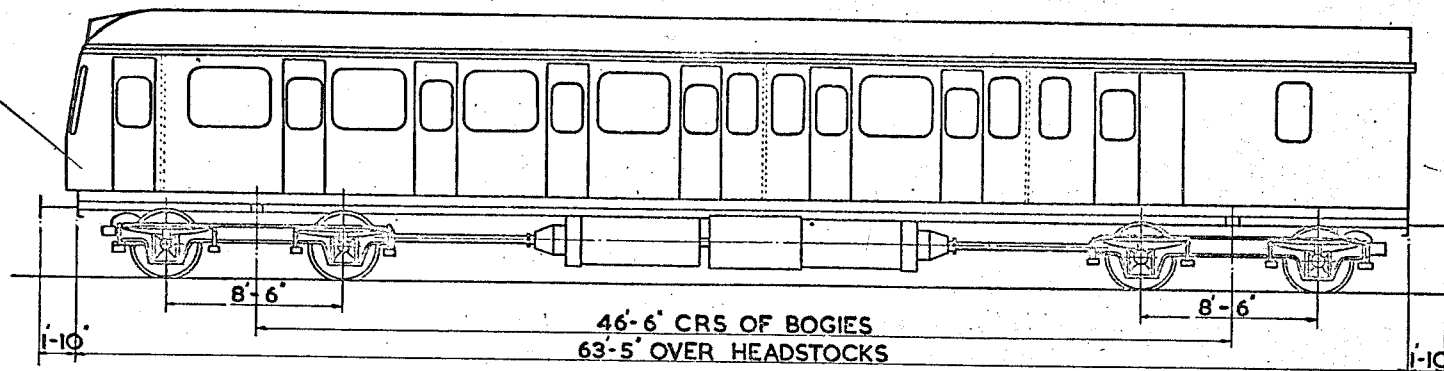

2 SECOND. 65 SEATS
 1 DRIVER
 1 GUARD & LUGGAGE
 N.S. - NON - SMOKING

2 x 238 H.P. R.R. ENGINES

LOT No
 30464

VEHICLE Nos.
 E51154 - E51173

BUILT AT
 DERBY

TARE
 39 T.

NON GANGWAYED SEMI-OPEN MOTOR SECOND.

B.R. 596.

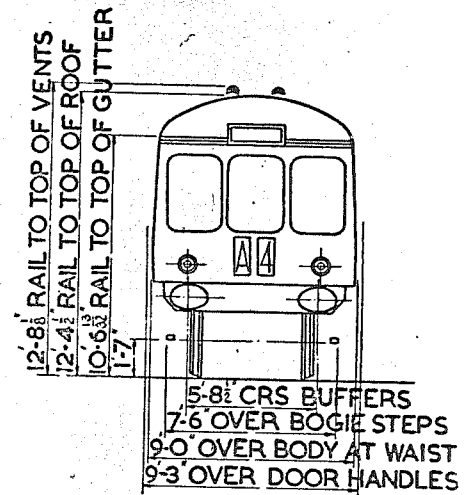
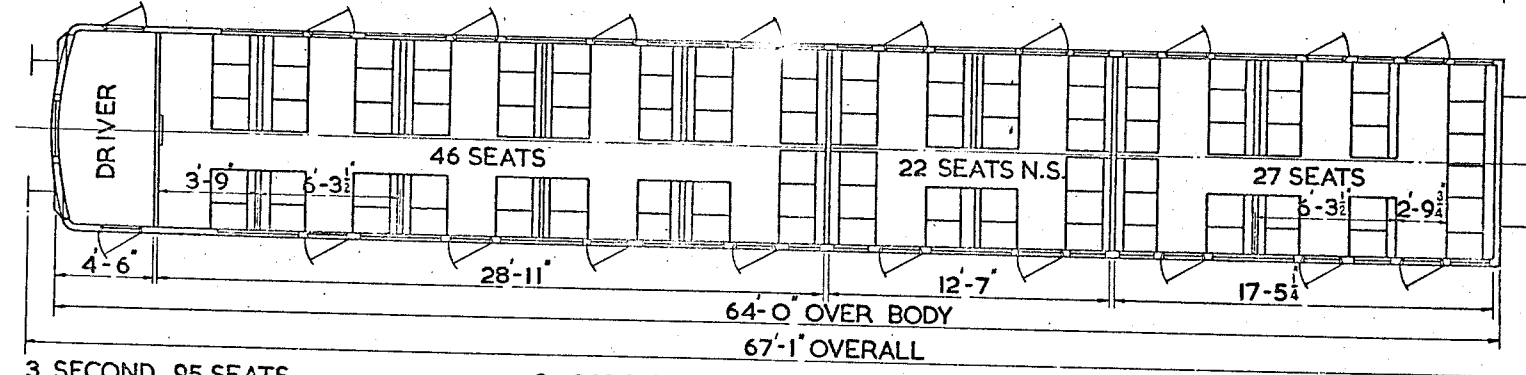
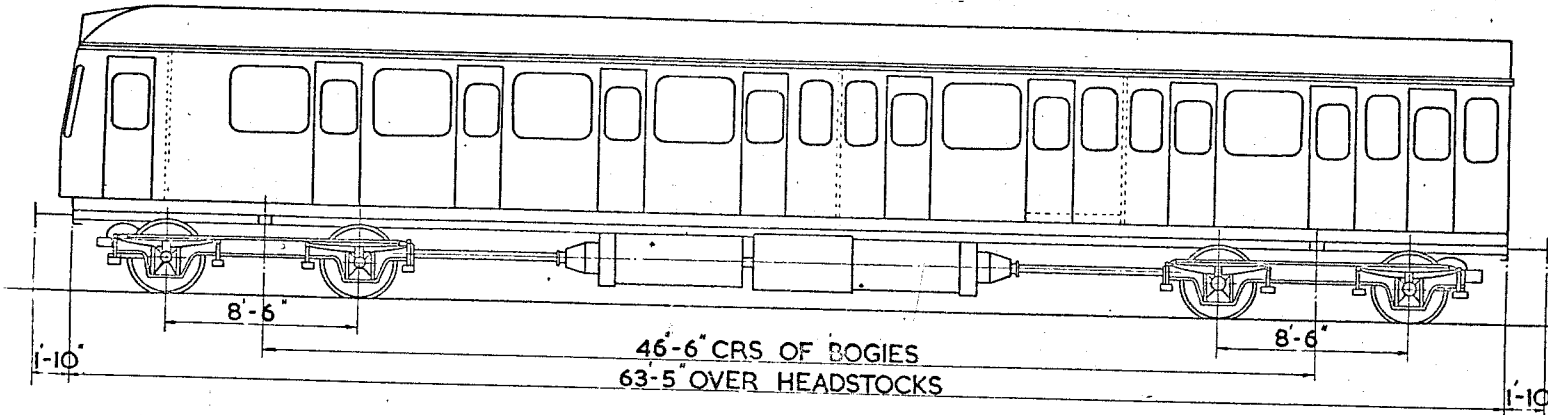

3 SECOND. 95 SEATS
 1 DRIVER
 N.S. - NON-SMOKING

2 238 H.P., R.R. ENGINES

LOT No.
 30462

VEHICLE Nos.
 E50988 - E51007

BUILT AT
 DERBY

TARE
 39 T.

NON GANGWAYED TRAILER SECOND.

B.R. 597

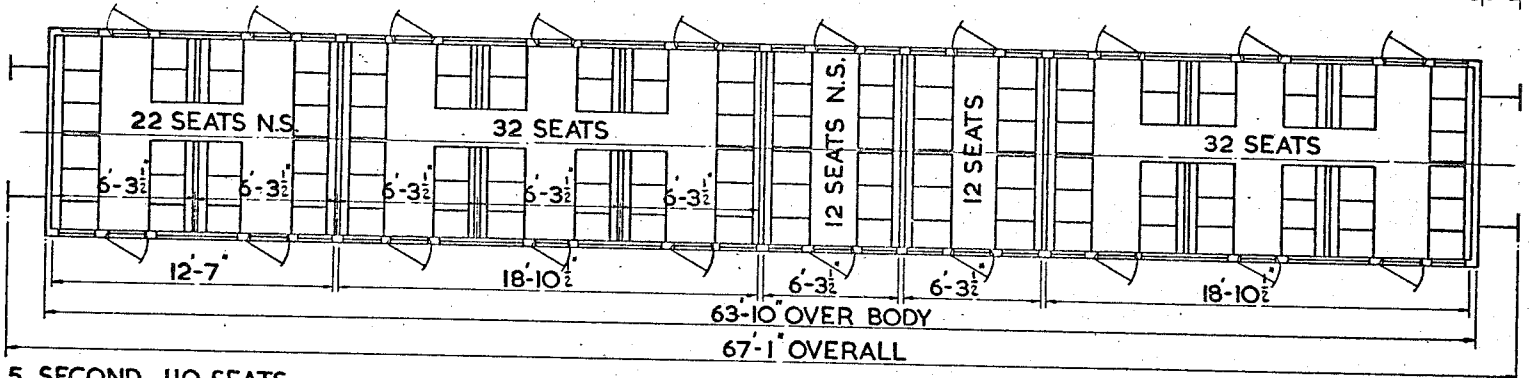
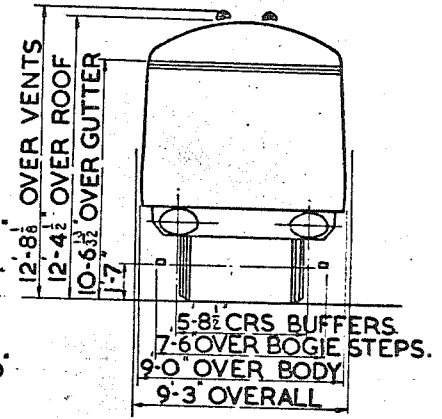
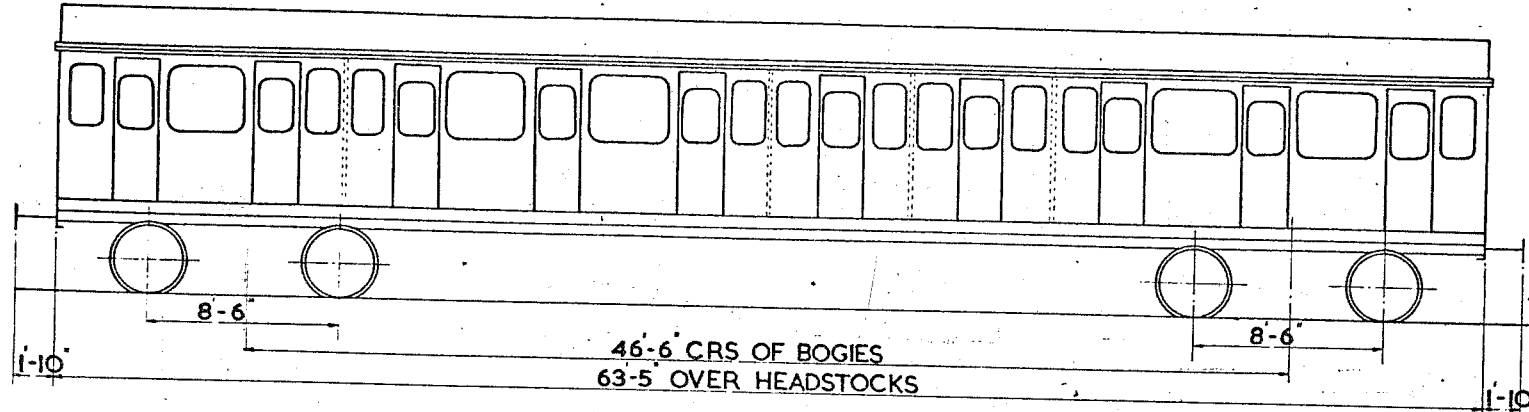

5 SECOND. 110 SEATS
N.S. - NON-SMOKING

LOT No.
30463

VEHICLE Nos.
E59449 - E59468

BUILT AT
DERBY

TARE
29 T.

NON GANGWAYED MOTOR SEMI-OPEN SECOND BRAKE.

B.R. 598.

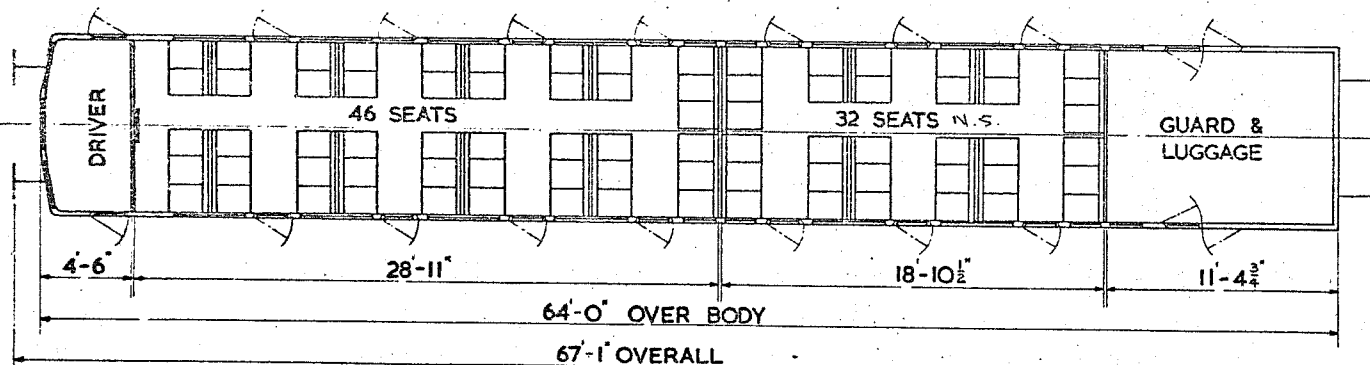
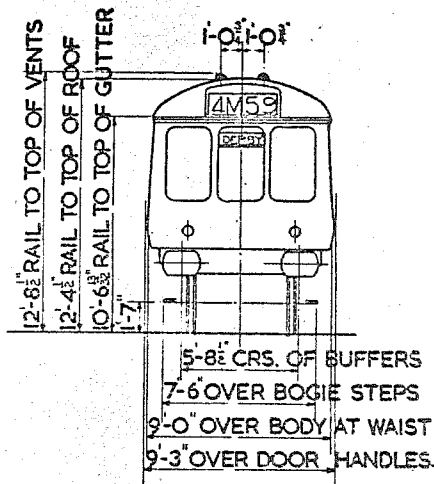
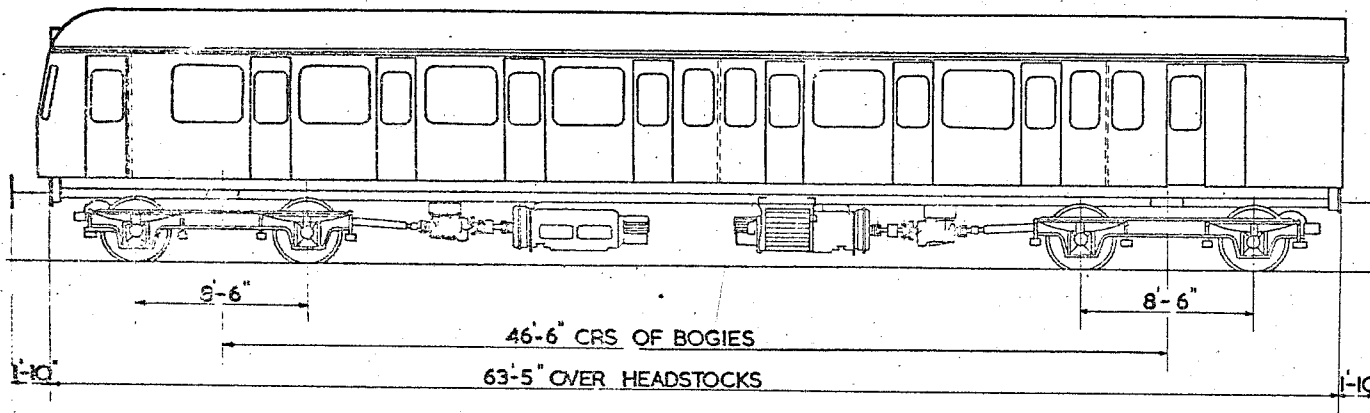

N.S. NON SMOKING
LOTS 30530 & 30598 ONLY.

2 SECOND 78 SEATS
1 DRIVING COMPARTMENT
1 GUARD & LUGGAGE

2-230 H.P. B.U.T. ENGINES.

LOT No	VEHICLE Nos
30530	51651 - M51680
30595	M51849 - M51860
30598	M51861 - M51900

BUILT AT
DERBY

TARE
38 T.

NON GANGWAYED OPEN TRAILER LAVATORY COMPOSITE.

B.R. 599.

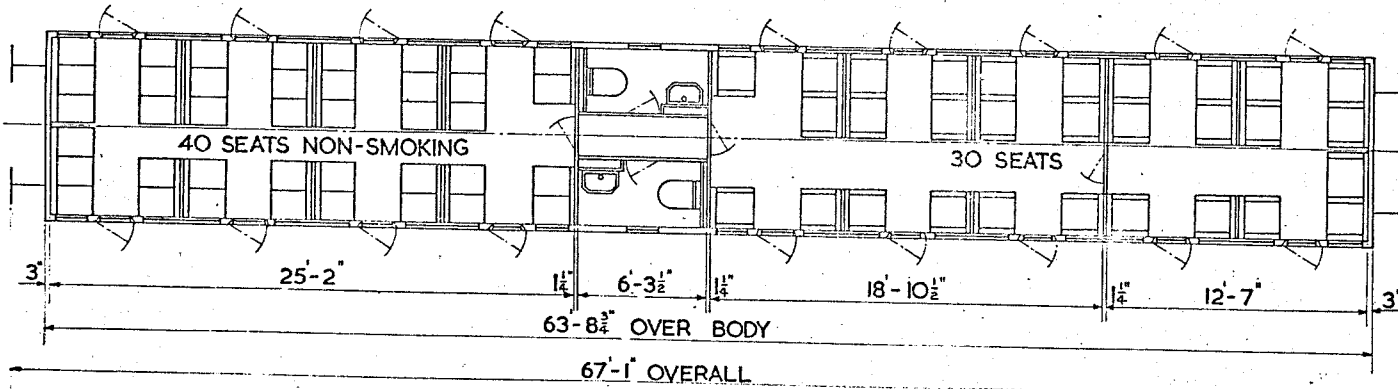
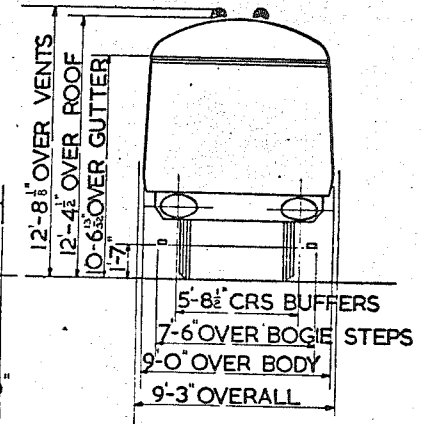
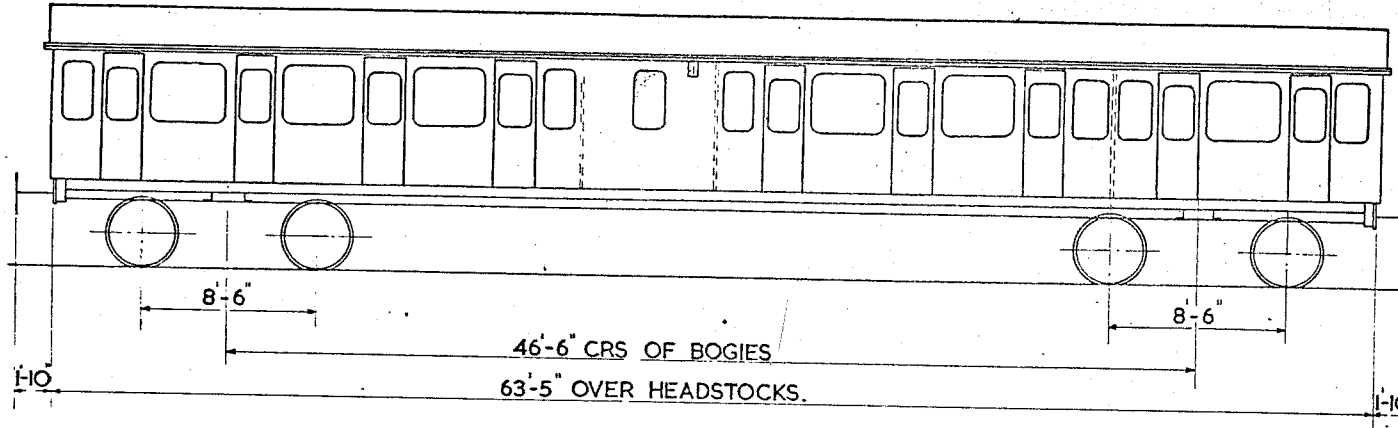

- 2 FIRST - 30 SEATS.
- 1 SECOND - 40 SEATS.
- 2 LAVATORIES.

LOT No	VEHICLE No
30532	M 664 - M59678
30597	M 59719 - M59724

BUILT AT	TARE
DERBY	30 T
"	"
"	"

NON-GANGWAYED TRAILER SECOND

B.R. 600

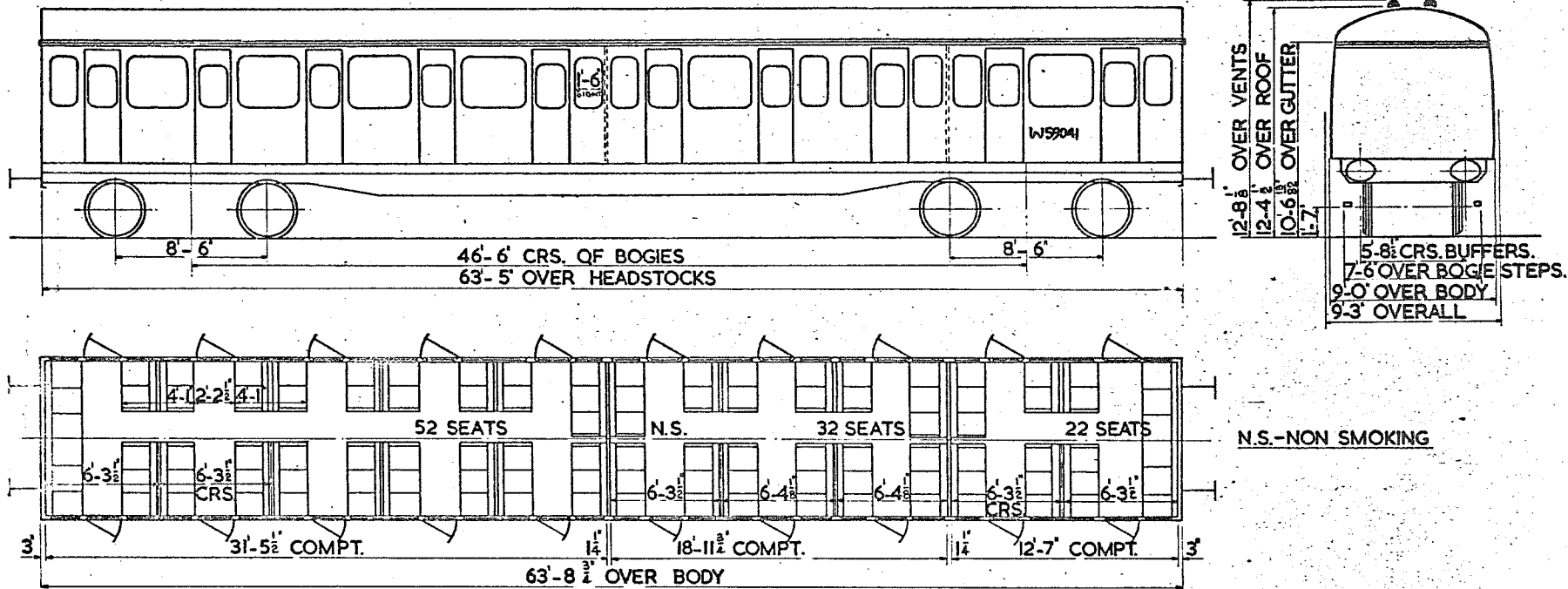

3 SECOND 106 SEATS

LOT No.
30385

VEH. No.
W59032-W59041

BUILT AT
DERBY

TARE
29 T.

NON-GANGWAYED OPEN TRAILER LAVATORY COMPOSITE.

B.R. 601

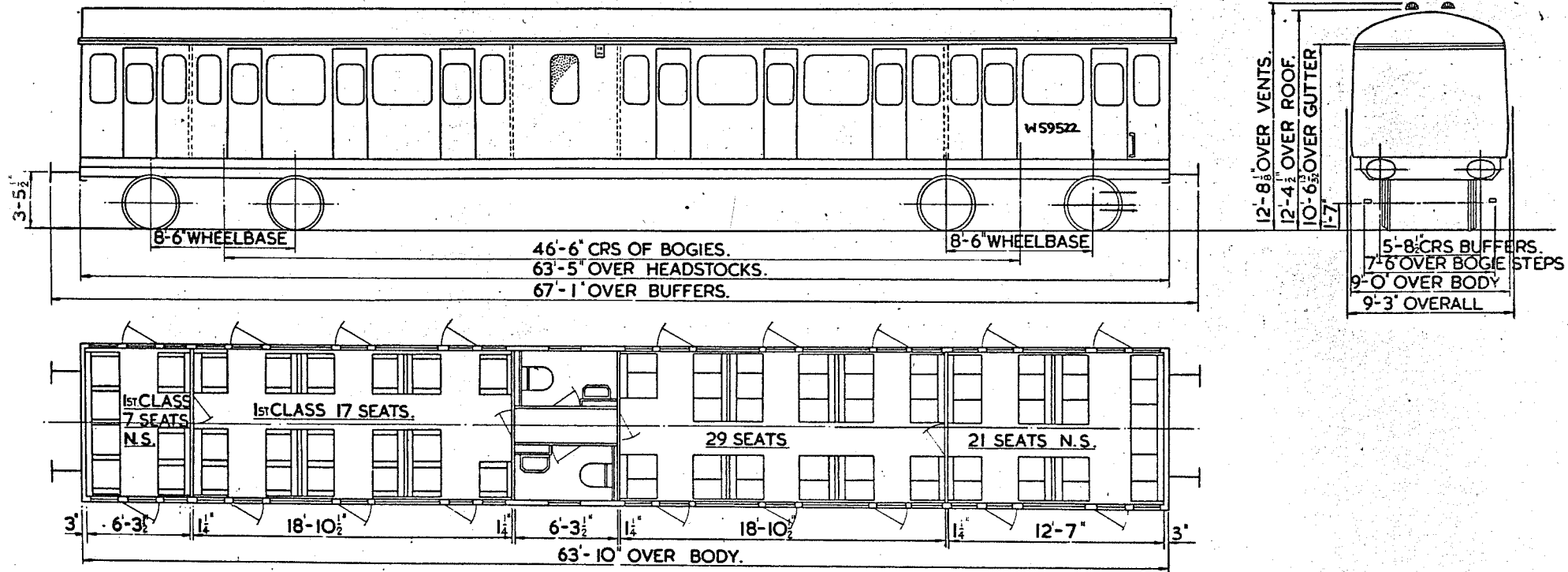

2 FIRST - 24 SEATS.
2 SECONDS - 50 SEATS.
2 LAVATORIES.

N.S.- NON SMOKING.

QTY	LOT	VEHICLE No.	BUILT AT.	TARE.
15	30544	W59469-W59483	B' HAM RLY	30T.
39	30547	W59484-W59522	C.&W. Co.	PRESSED STEEL 30T

B.R. 602

GANGWAYED MOTOR OPEN SECOND BRAKE.

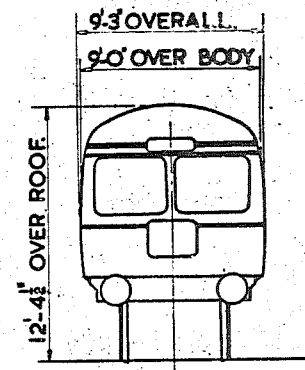
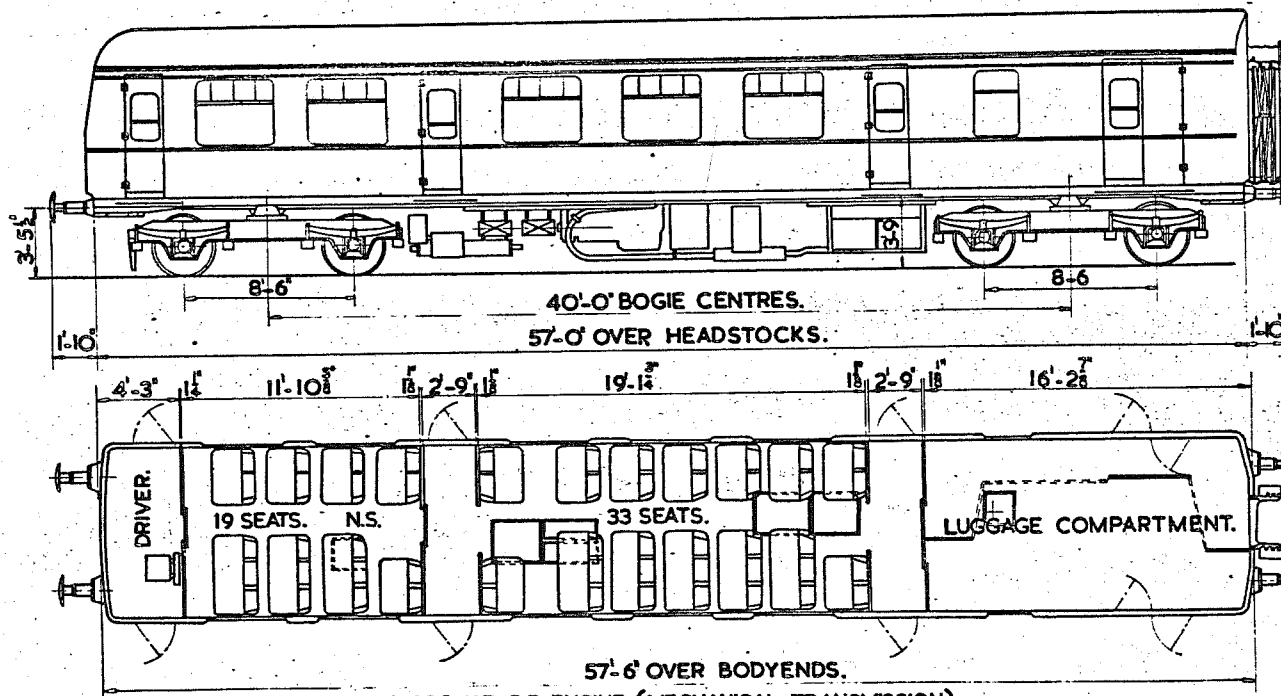

- 2 SECOND 52 SEATS.
- 1 DRIVING COMPARTMENT.
- 1 GUARDS COMPARTMENT.

1x238 H.P. R.R. ENGINE (MECHANICAL TRANSMISSION).

LOT No.
30533

VEHICLE Nos.
M51681-M51705

BUILT AT
CRAVENS

TARE
30 T.

GANGWAYED MOTOR OPEN COMPOSITE LAVATORY

B.R. 603.

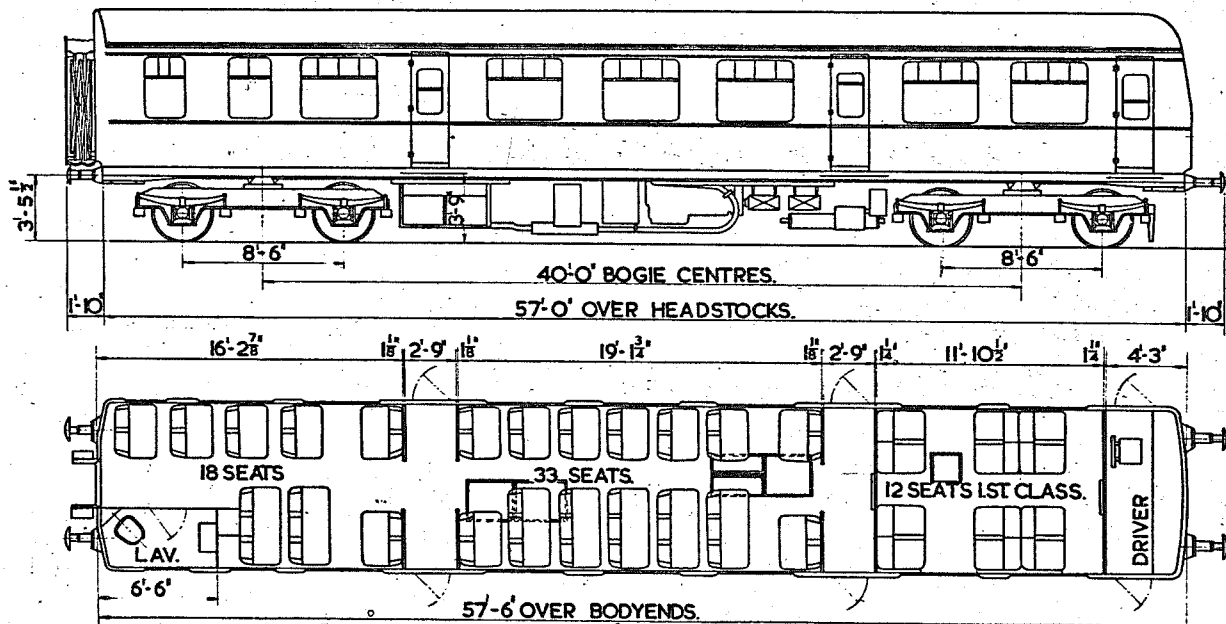
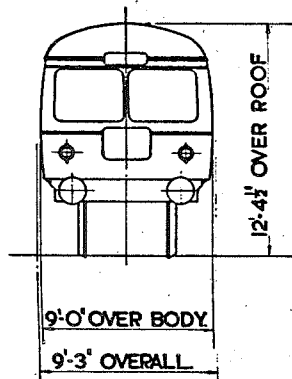

- 1 FIRST 12 SEATS.
- 2 SECOND 51 SEATS.
- 1 DRIVING COMPARTMENT
- 1 LAVATORY.

1x238 H.P. R.R. ENGINE (MECHANICAL TRANSMISSION).

LOT No
30534

VEHICLE Nos.
M 51706-M51730

BUILT AT
CRAVENS

TARE
30 T.

GANGWAYED MOTOR OPEN SECOND BRAKE

B.R. 604.

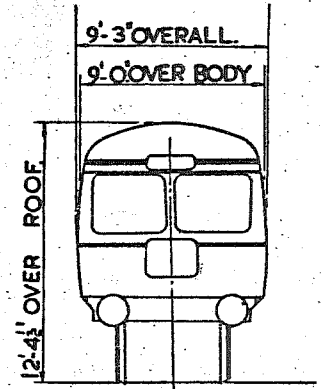
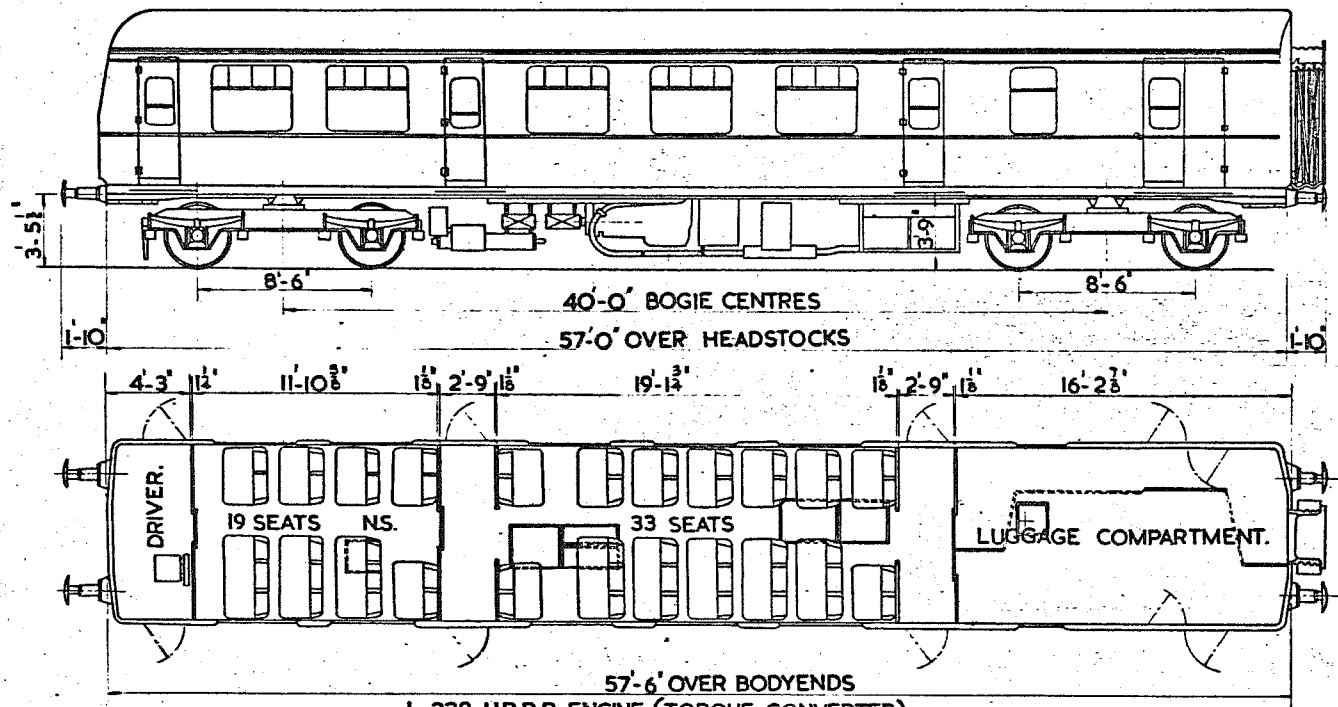

- I SECOND 52 SEATS.
- I DRIVING COMPARTMENT.
- I GUARDS COMPARTMENT.

1 x 238 H.P. R.R. ENGINE (TORQUE CONVERTER)

LOT No.
30535

VEHICLE Nos.
M51731-M51755

BUILT AT
CRAVENS.

TARE
30 T.

GANGWAYED MOTOR OPEN COMPOSITE LAVATORY

B.R. 605.

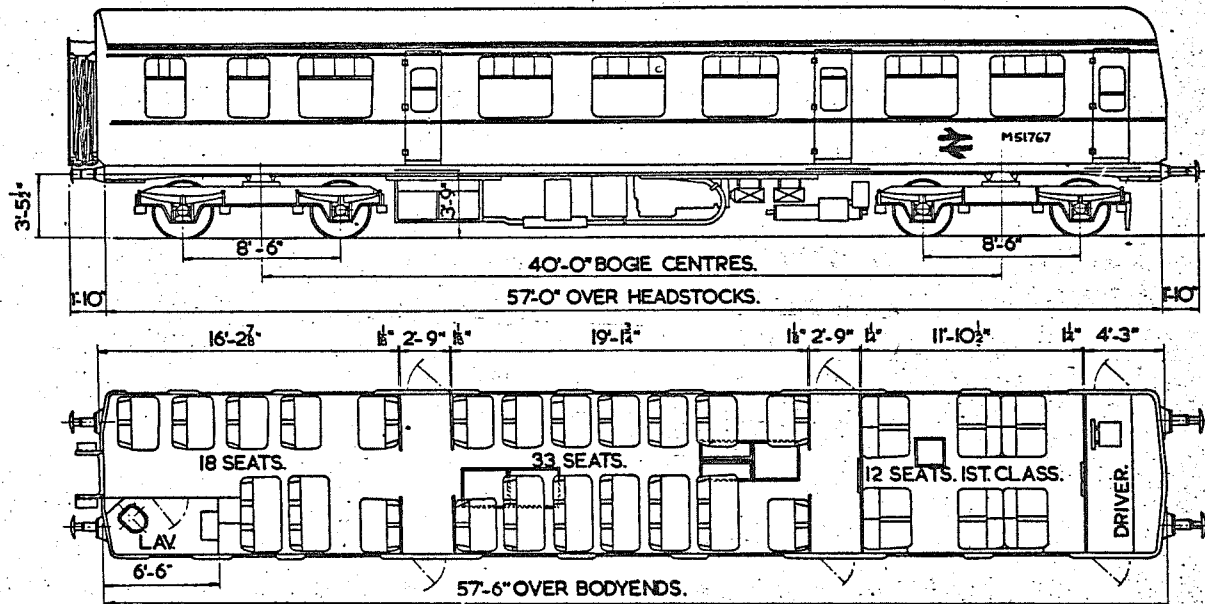
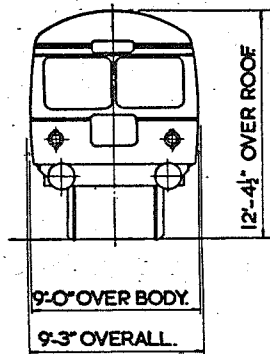

- 1 FIRST 12 SEATS.
 - 2 SECOND 51 SEATS.
 - 1 DRIVING COMPARTMENT.
 - 1 LAVATORY.
- 1 x 238 H.P. R.R. ENGINE (TORQUE CONVERTER)

LOT No.
30536

VEHICLE Nos.
M 51756 - M51780

BUILT AT
CRAVENS.

TARE
30 T.

GANGWAYED MOTOR OPEN SECOND BRAKE

B.R. 606.

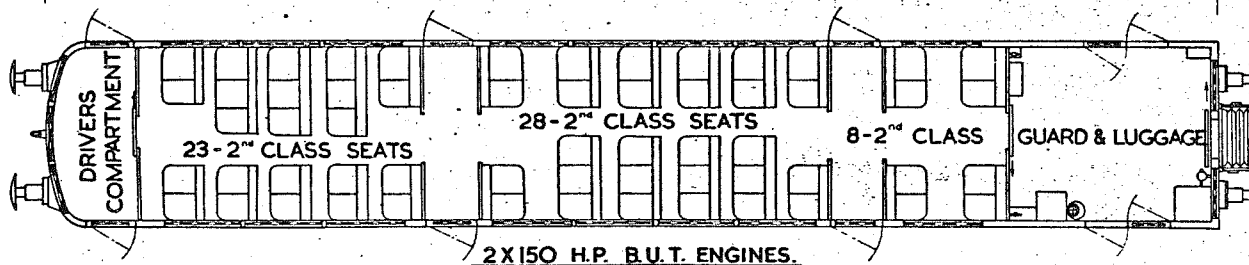
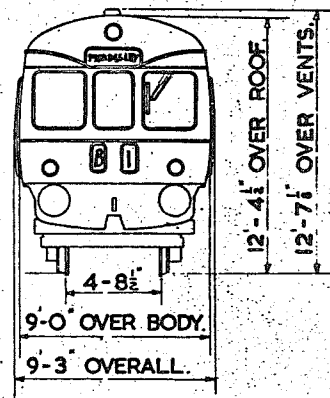
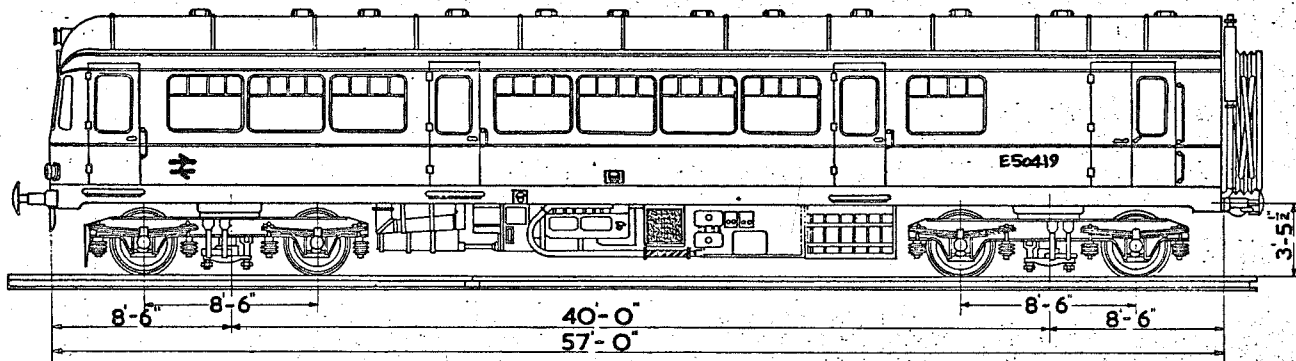

3 SECOND 59 SEATS.
1 DRIVING COMPARTMENT.
1 GUARD & LUGGAGE.

LOT No.
30288

VEHICLE Nos.
E50415 - E50419

BUILT AT
WICKHAM & CO. LTD.

TARE
27 T.

GANGWAYED DRIVING TRAILER OPEN COMPOSITE LAVATORY

B.R. 607.

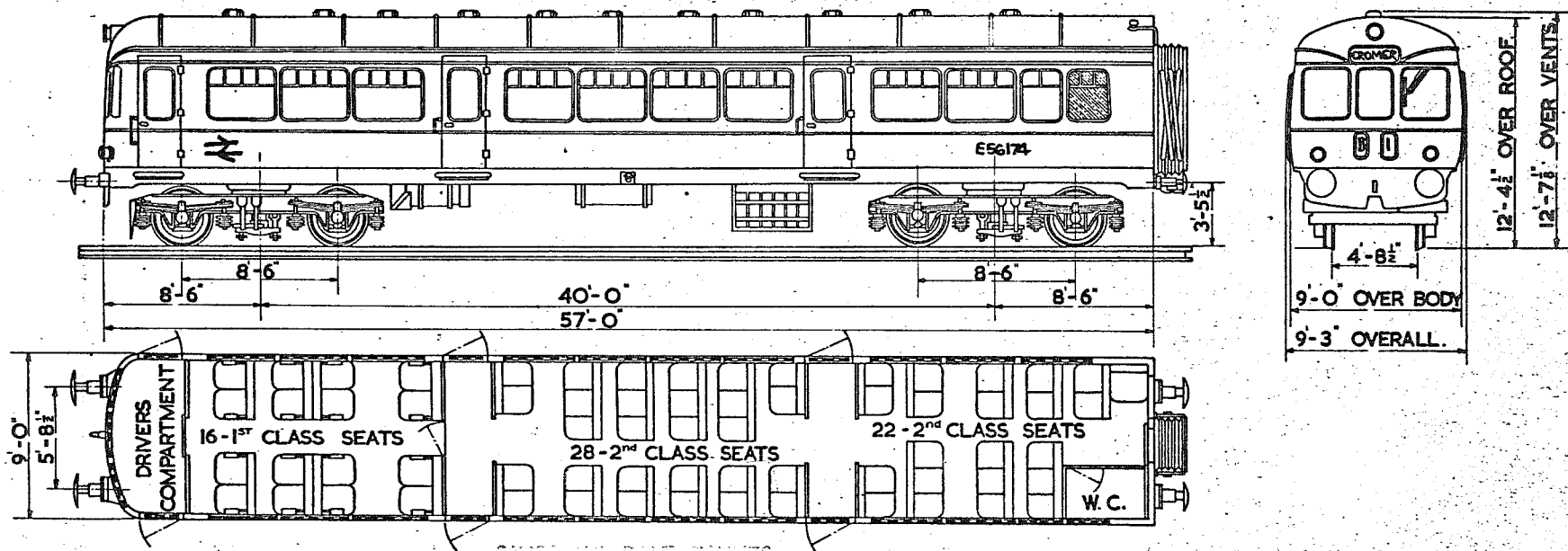

- 1 FIRST 16 SEATS.
- 2 SECOND 50 SEATS.
- 1 DRIVING COMPARTMENT.
- 1 LAVATORY.

LOT No
30289

VEHICLE Nos.
E56170 - E56174

BUILT AT
WICKHAM & CO. LTD.

TARE
22 1/2 T

(Now Withdrawn)

GANGWAYED MOTOR OPEN COMPOSITE LAVATORY.

B.R. 609

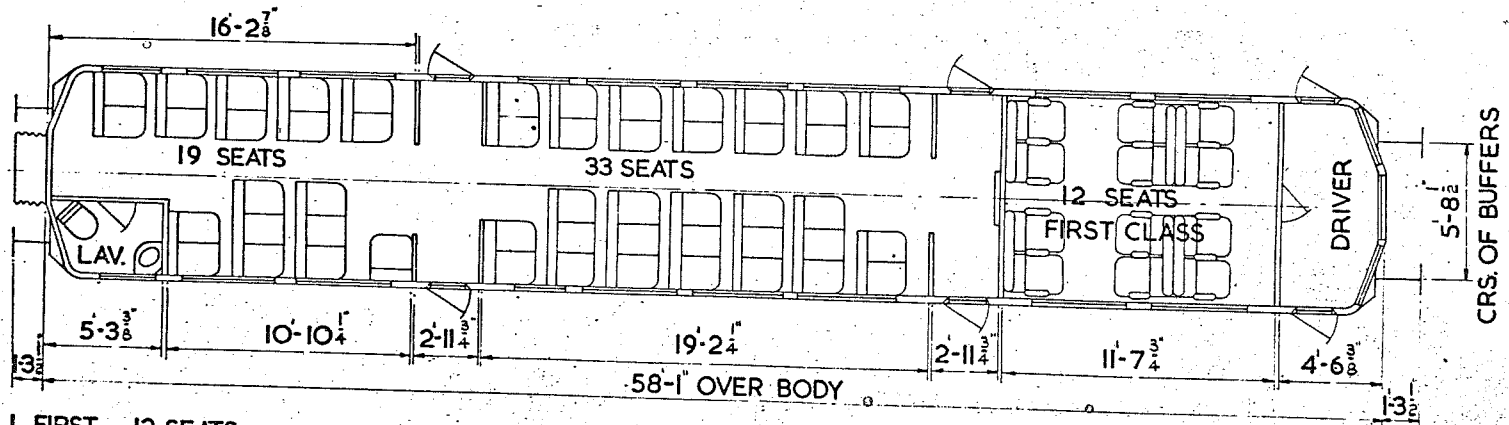
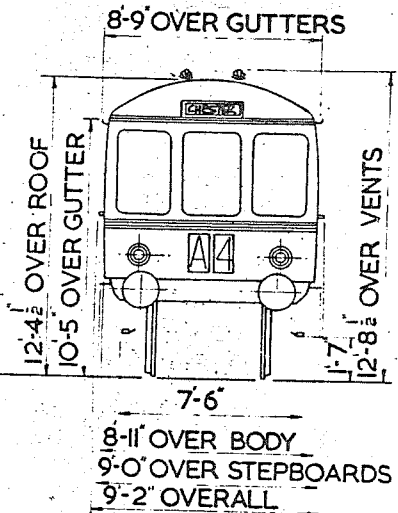
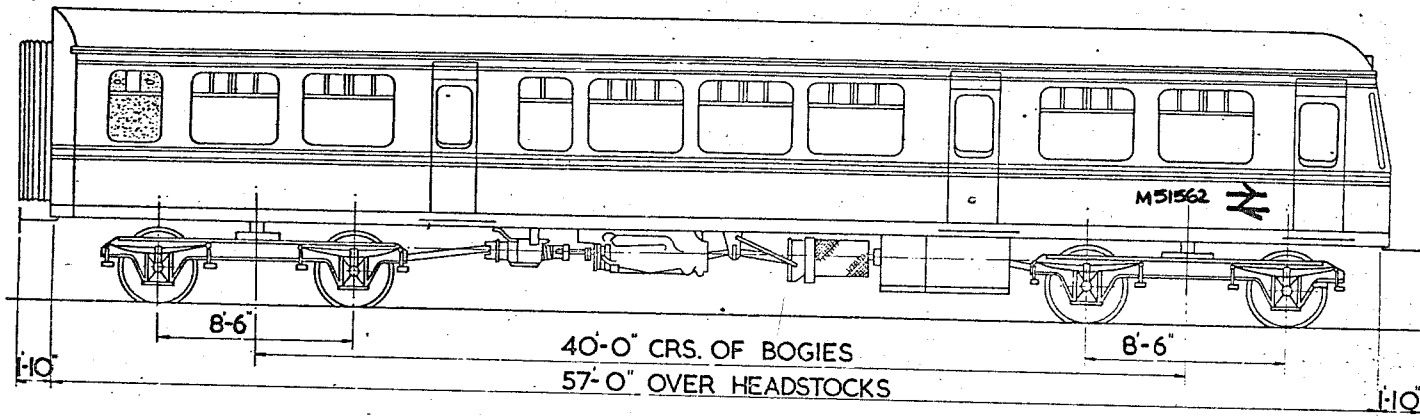

- 1 FIRST. 12 SEATS.
- 2 SECOND. 52 SEATS.
- 1 DRIVING COMPARTMENT.
- 1 LAVATORY.

2 x 150 H.P. B.U.T. ENGINES.

LOT No.	VEHICLE Nos.	BUILT AT.	TARE.
30	M51561-M51572	DERBY	28 T.

DIESEL RAILBUS

BR.610.

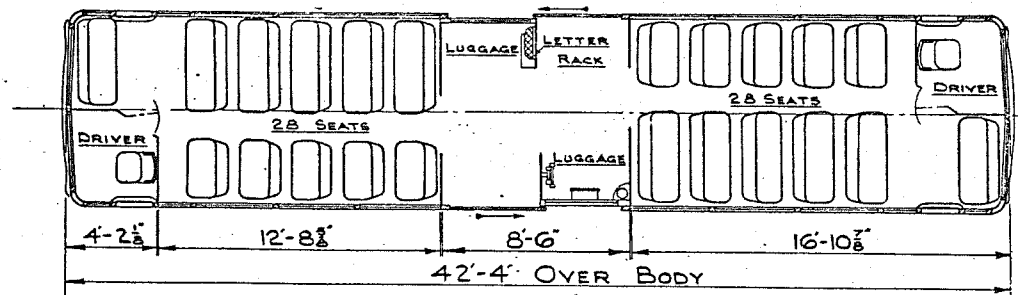
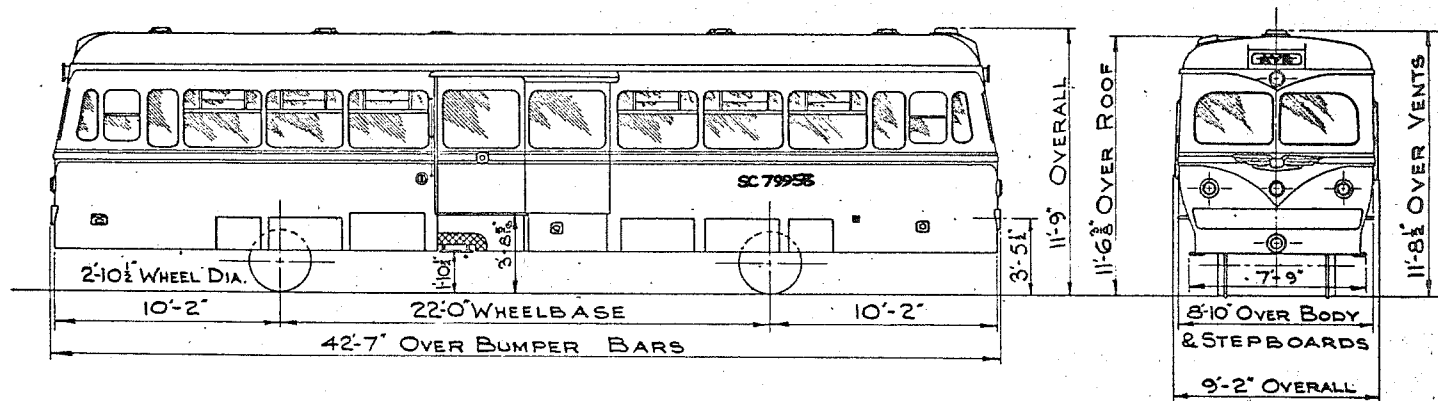

QTY	LOT	TARE TONS	CWTS	BUILT BY
2	30483	13	10	BRISTOL COMMERCIAL VEHICLES LTD. & EASTERN COACH WORKS LTD.

VEHICLE No . SC.79958 - SC.79959.

2 SECONDS 56 SEATS



DIESEL RAILBUS

BR. 611

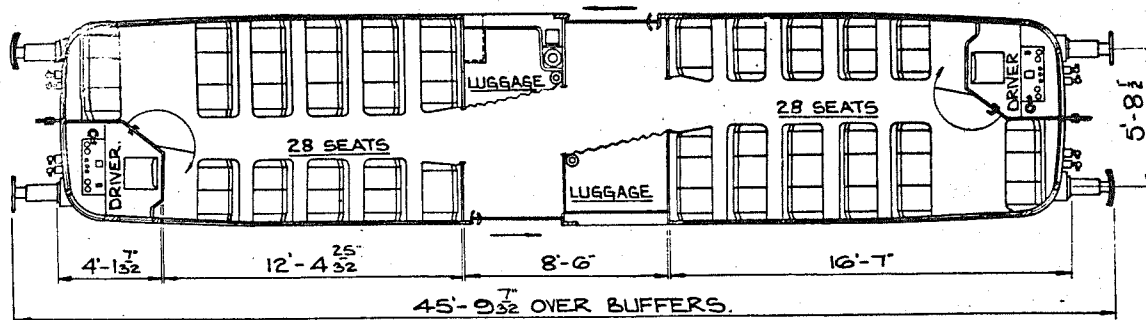
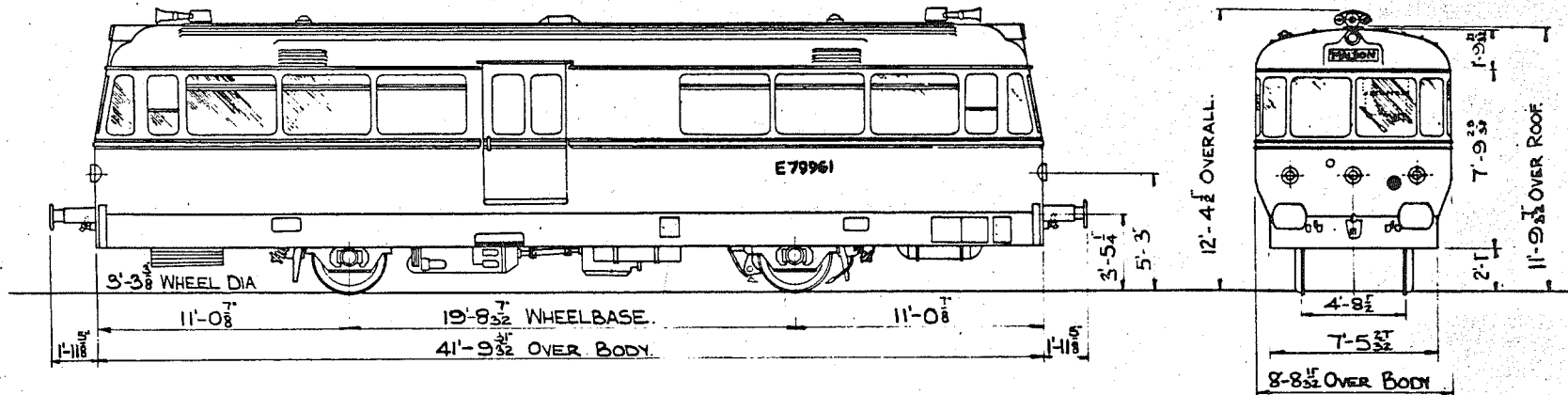

QTY.	LOT.	TARE TONS	BUILT BY
5	30482	15	W.M. DONAUWÖRTH WEST GERMANY

VEHICLE NOS E.79960 - E.79964

2 SECONDS 56 SEAT 3



DIESEL RAILBUS

BR. 612.

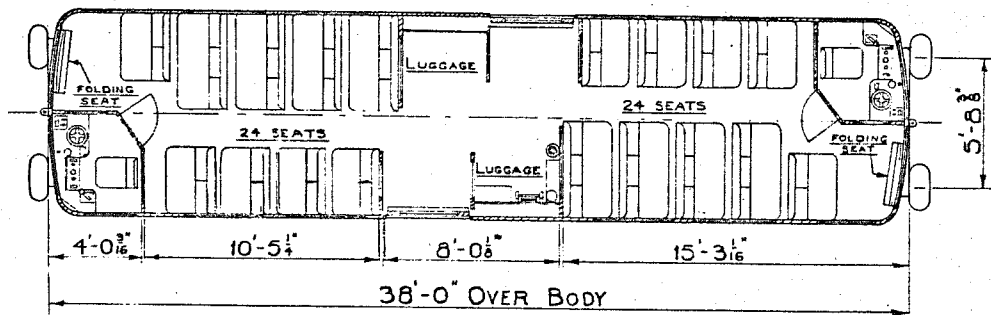
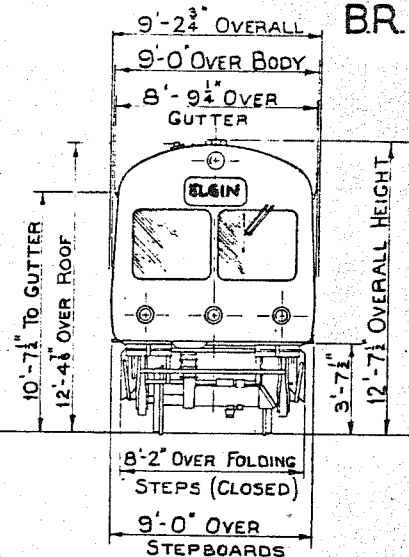
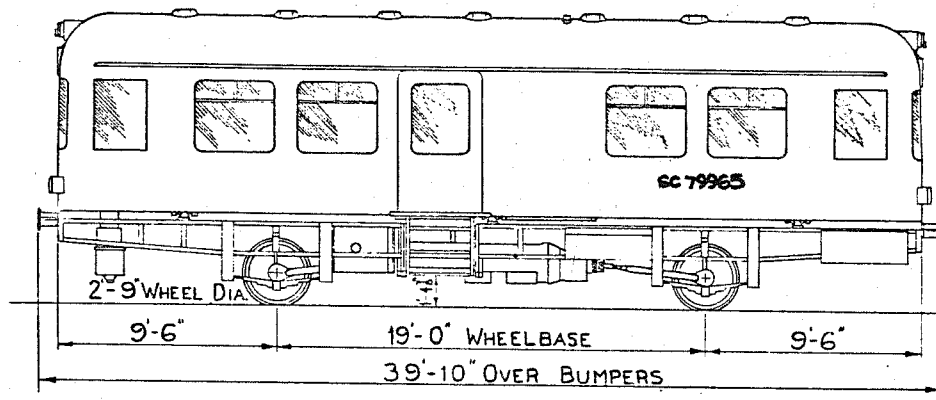

QTY	LOT	TARE TONS	CWTS	BUILT BY
5	30481	11	- 10	D. WICKHAM & CO LTD WARE, HERTS.

VEHICLE NOS. Sc79965 - Sc79969.

2 SECONDS 4 SEATS (INCLUDING FOLDING SE. 3)



DIESEL RAILBUS

B.R. 613.

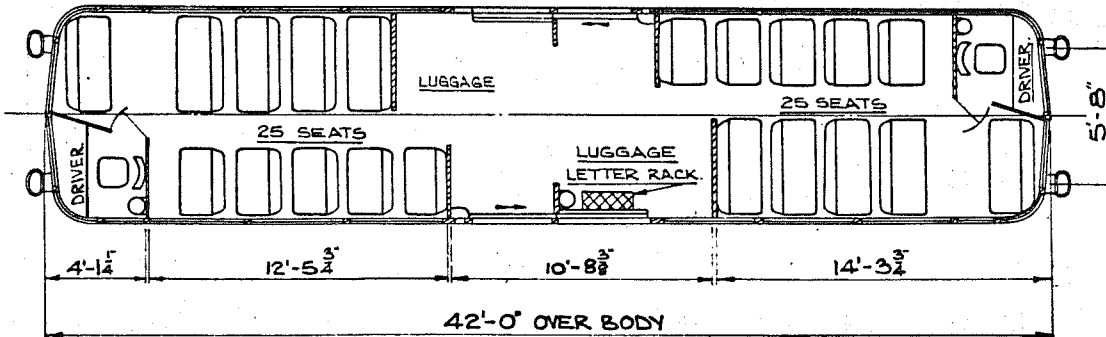
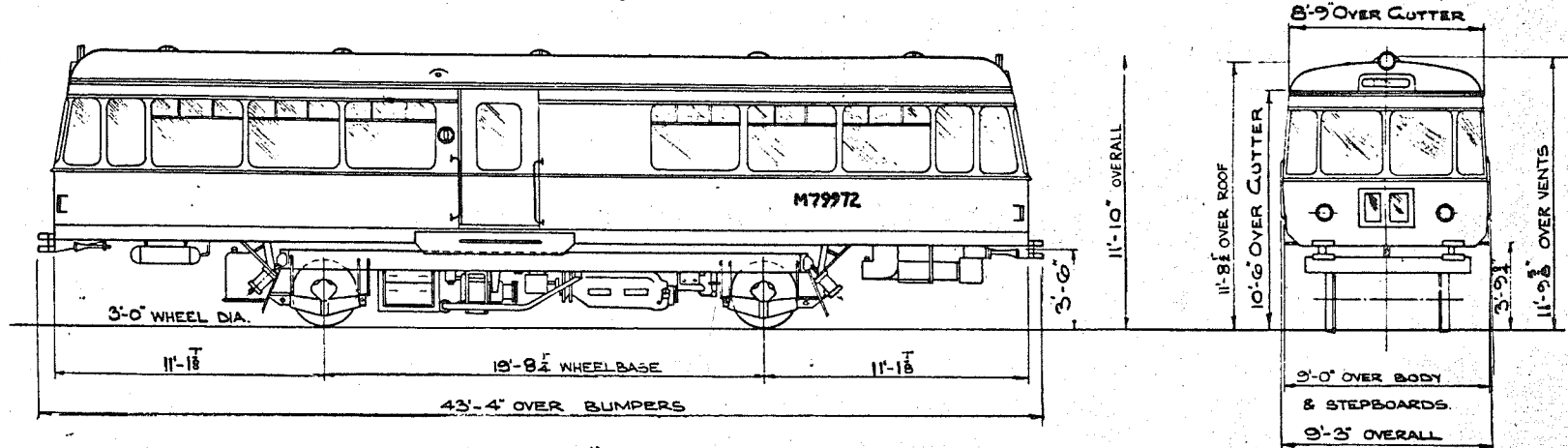

QTY.	LOT	TARE TONS	CWTS	BUILT BY
5	30480	15 - 0		PARK ROYAL VEHICLES LTD.

VEHICLE Nos M.79971 - M79973
 Sc.79970 & Sc.79974

2 SECONDS 50 SEAT



DIESEL RAILBUS

B.R. 614.

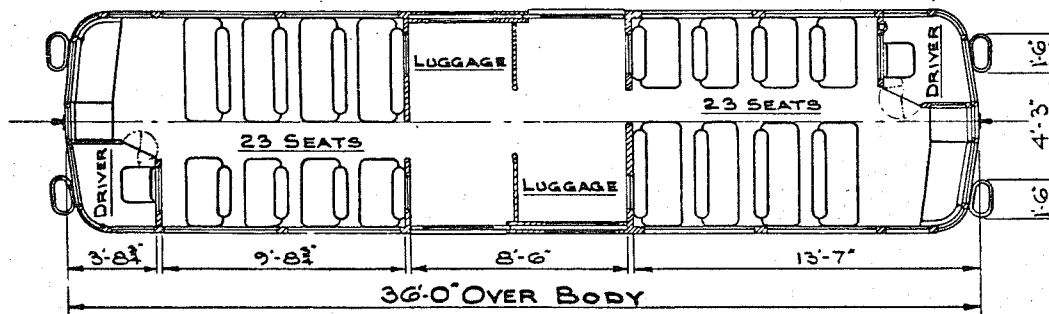
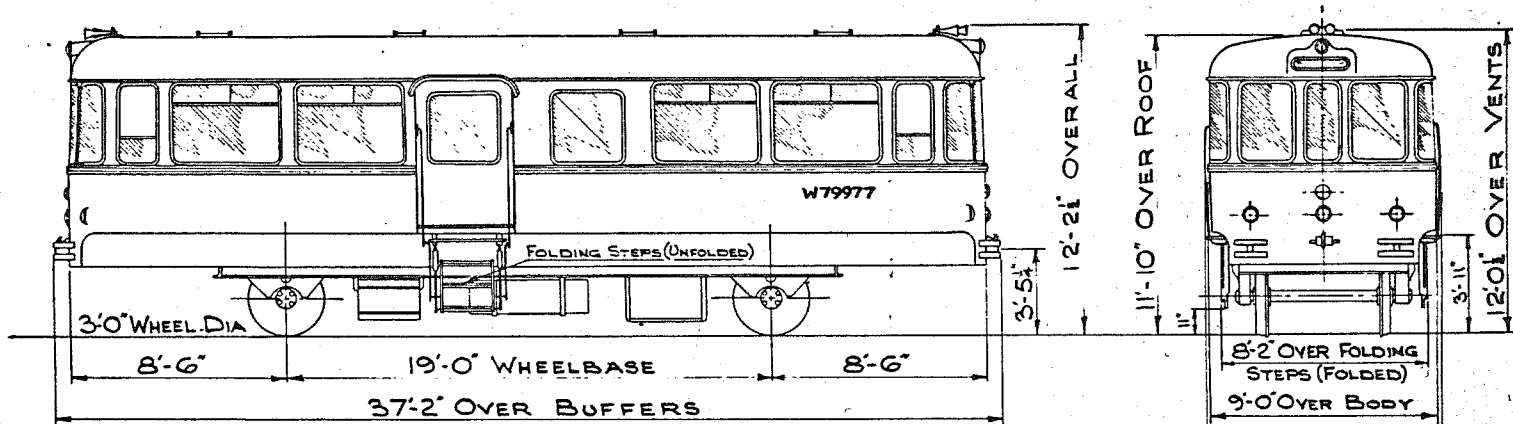

QTY	LOT	TARE TONS	CWTS	BUILT BY
5	30479	11	- 0	AC.CARS LTD

VEHICLE NOS. Sc79979.
 W79975 - W79978.

2 SECONDS.46 SE. MS.



GANGWAYED MOTOR OPEN SECOND BRAKE

B R. 615.

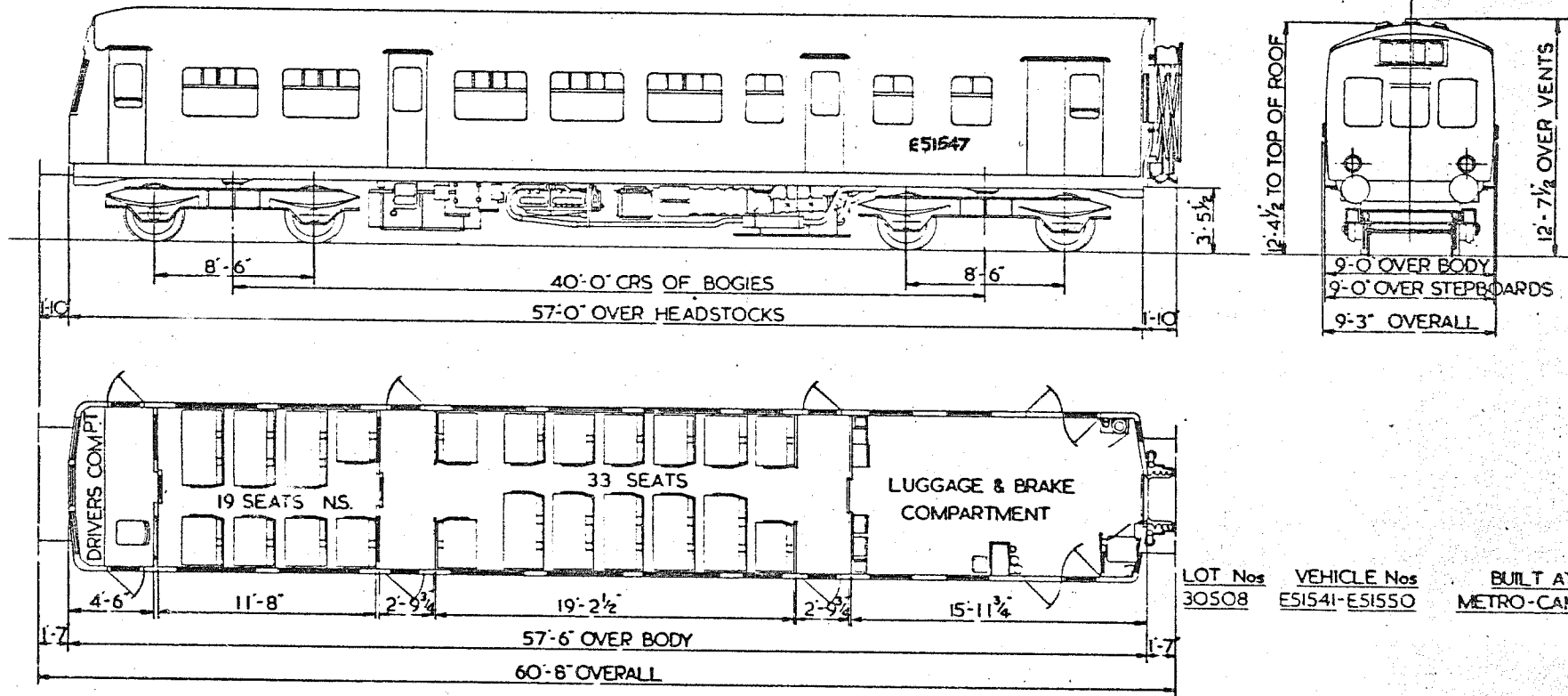

LOT Nos	VEHICLE Nos	BUILT AT	TARE
30508	E51541-E51550	METRO-CAMMELL	33 T

- 2 - SECOND 52 SEATS
- 1 - DRIVERS COMPARTMENT
- 1 - LUGGAGE COMPARTMENT

NS NON SMOKING

2 x 180 HP R.R. ENGINES

GANGWAYED MOTOR OPEN COMPOSITE LAVATORY

BR.616.

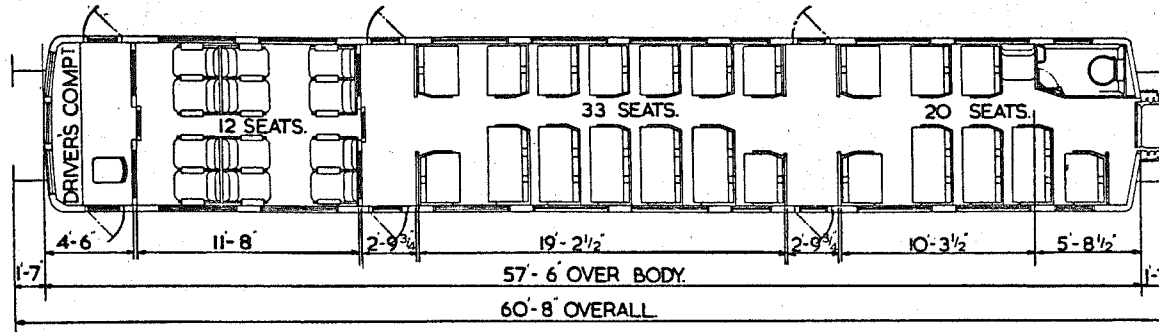
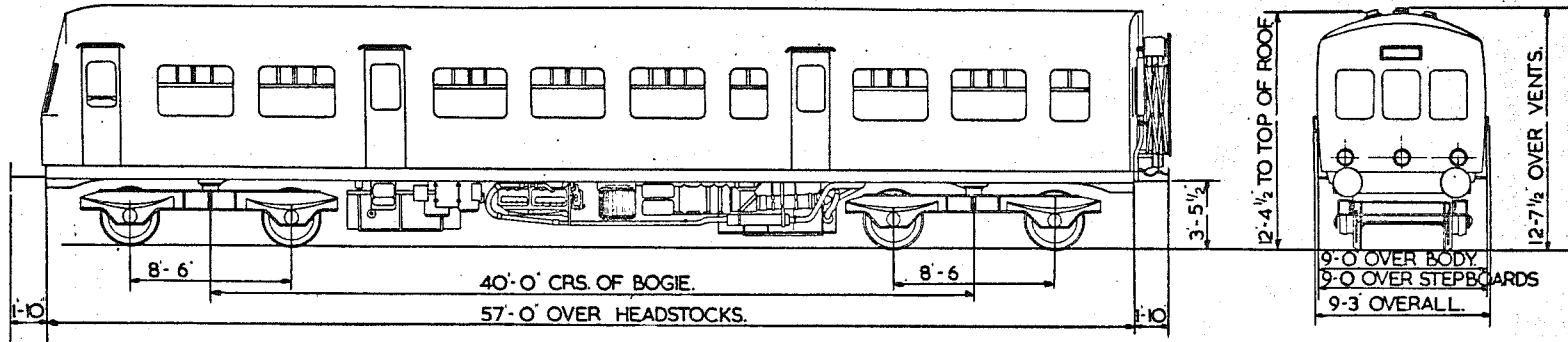

LOT N ^{os}	VEHICLE N ^{os}	BUILT BY	TARE
30268	E50270-E50279	METRO-CAMMELL	33 T

- 1 - FIRST. 12 SEATS.
- 2 - SECOND. 53 SEATS.
- 1 - DRIVERS COMPARTMENT.
- 1 - LAVATORY.

2 X 180 HP R.R. ENGINES

GANGWAYED MOTOR OPEN COMPOSITE LAVATORY

B.R. 617.

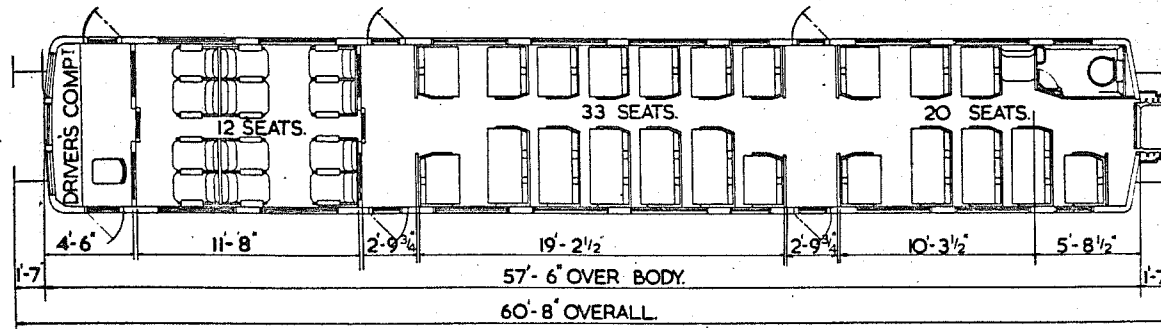
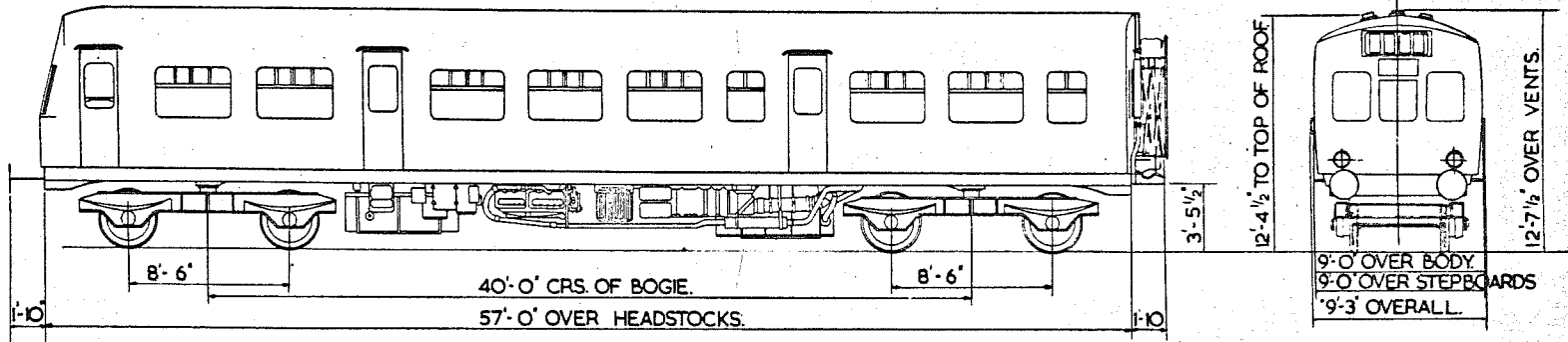

LOT N ^{os}	VEHICLE N ^{os}	BUILT BY	TARE
30509	E5151-E51560	METRO-CAMMELL	33T

- 1 - FIRST. 12 SEATS.
- 2 - SECOND. 53 SEATS.
- 1 - DRIVERS COMPARTMENT.
- 1 - LAVATORY.

2 X 180 HP R.R. ENGINES

GANGWAYED MOTOR OPEN COMPOSITE LAVATORY

BR. 618.

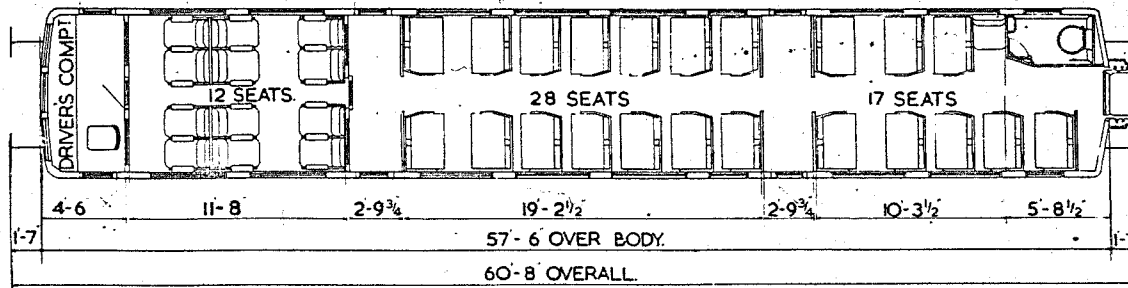
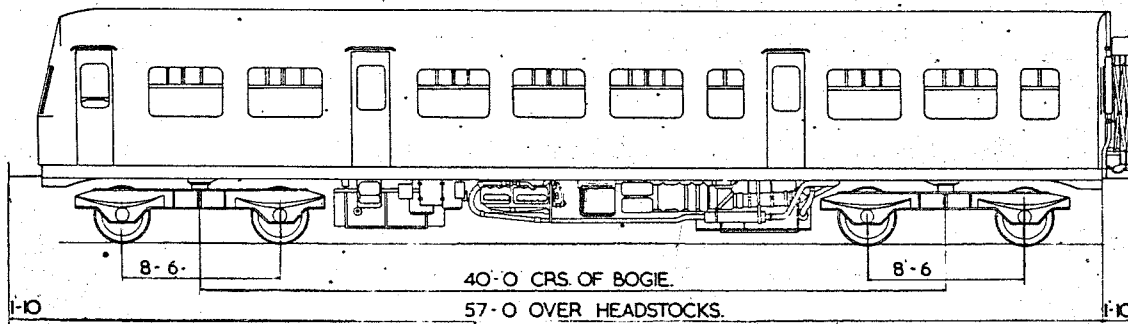

LOT N ^{os}	VEHICLE N ^{os}	BUILT BY	TARE
30249	E50138-E50151	METRO-CAMMELL	32T

- 1 - FIRST. 12 SEATS.
- 2 - SECOND. 45 SEATS.
- 1 - DRIVERS COMPARTMENT.
- 1 - LAVATORY.

2 X 1 HP BUT. ENGINES

GANGWAYED MOTOR OPEN COMPOSITE LAVATORY

B R. 619.

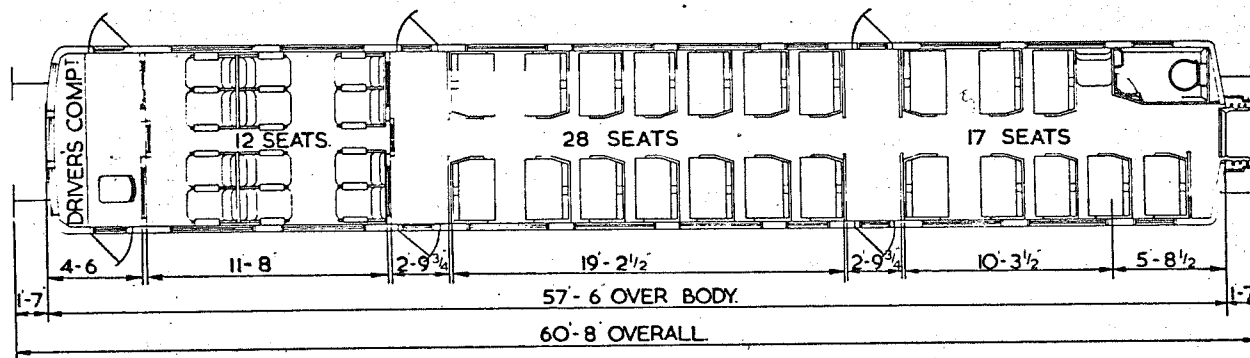
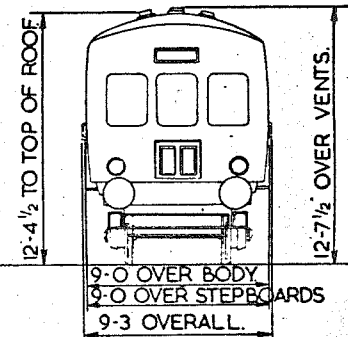
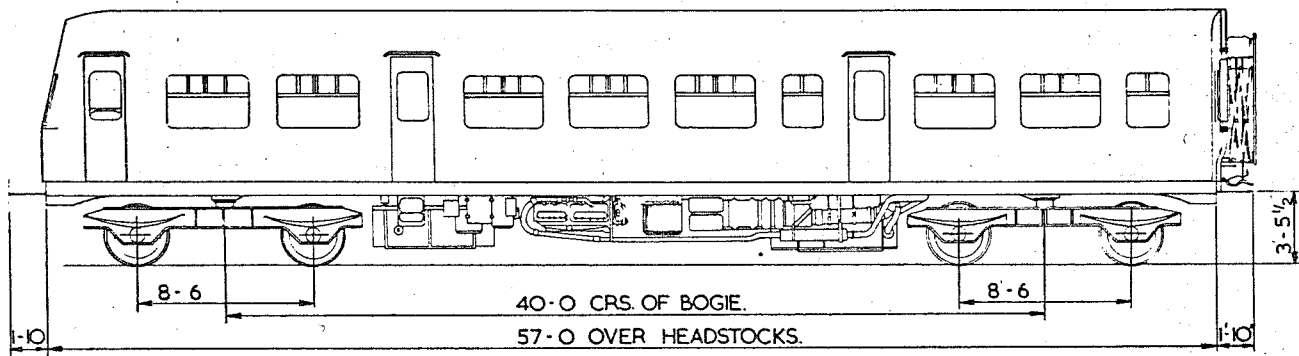

LOT N ^{os}	VEHICLE N ^{os}	BUILT BY	TARE
30263	E50234-E50245	METRO-CAMMELL	32T

- 1 - FIRST. 12 SEATS.
- 2 - SECOND. 45 SEATS.
- 1 - DRIVERS COMPARTMENT.
- 1 - LAVATORY.

2 X 150 HP B.U.T. ENGINES

GANGWAYED MOTOR OPEN COMPOSITE LAVATORY

B.R. 620.

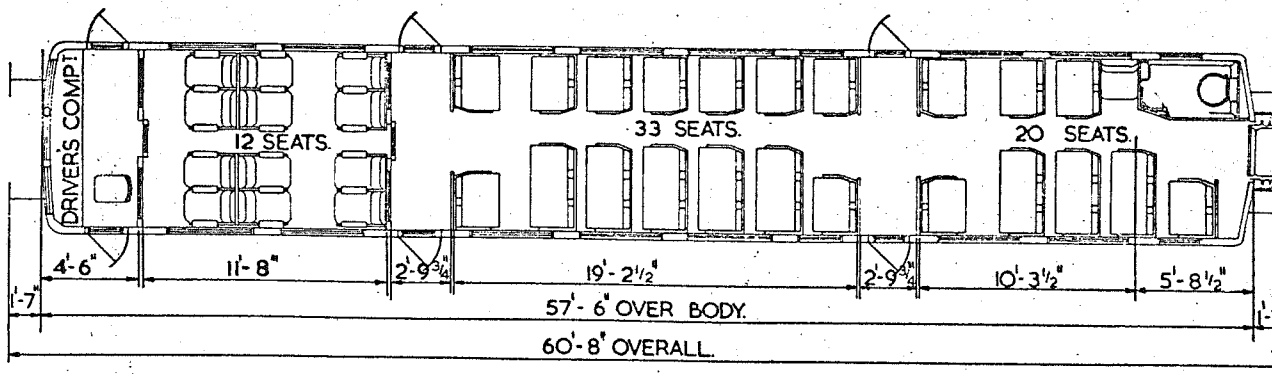
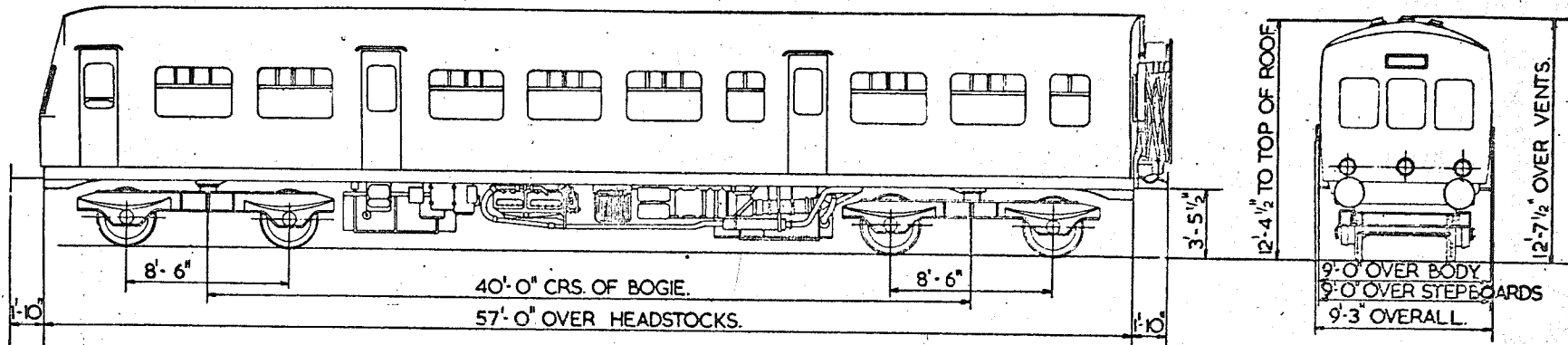

LOT N ^{os}	VEHICLE N ^{os}	BUILT BY	TARE
30253	ES0158 - ES0163	METRO-CAMMELL	32T
30255	ES0168 ES0171		
30256	ES0172 ES0197		

- 1 - FIRST. 12 SEATS.
- 2 - SECOND. 53 SEATS.
- 1 - DRIVERS COMPARTMENT.
- 1 - LAVATORY.

GANGWAYED MOTOR OPEN COMPOSITE LAVATORY

BR. 621.

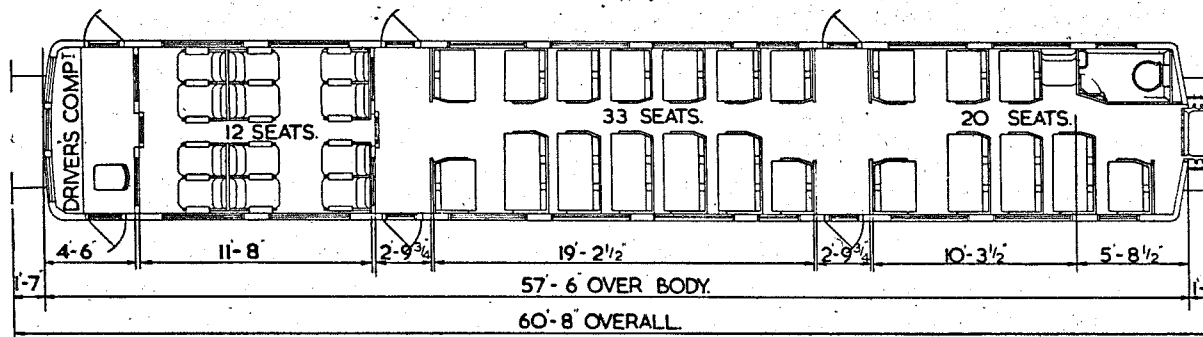
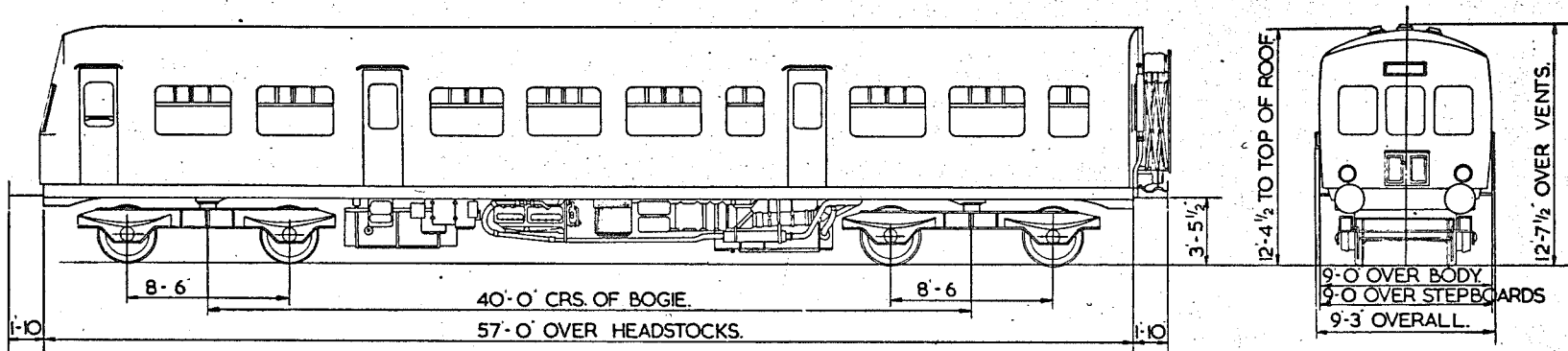

LOT Nos	VEHICLE Nos	BUILT BY	TARE
30267	E50260-E50269	METRO-CAMMELL	32T
30271	E50745 - E50751		
30276	M50321 M50338		
30501	E51495 E51514 SC51515 SC51540		
30588	SC51802 SC51808		

- 1 - FIRST. 12 SEATS.
- 2 - SECOND. 53 SEATS.
- 1 - DRIVERS COMPARTMENT.
- 1 - LAVATORY.

2 X 150 HP. B.U.T. ENGINES

GANGWAYED TRAILER OPEN SECOND LAVATORY.

B.R. 622

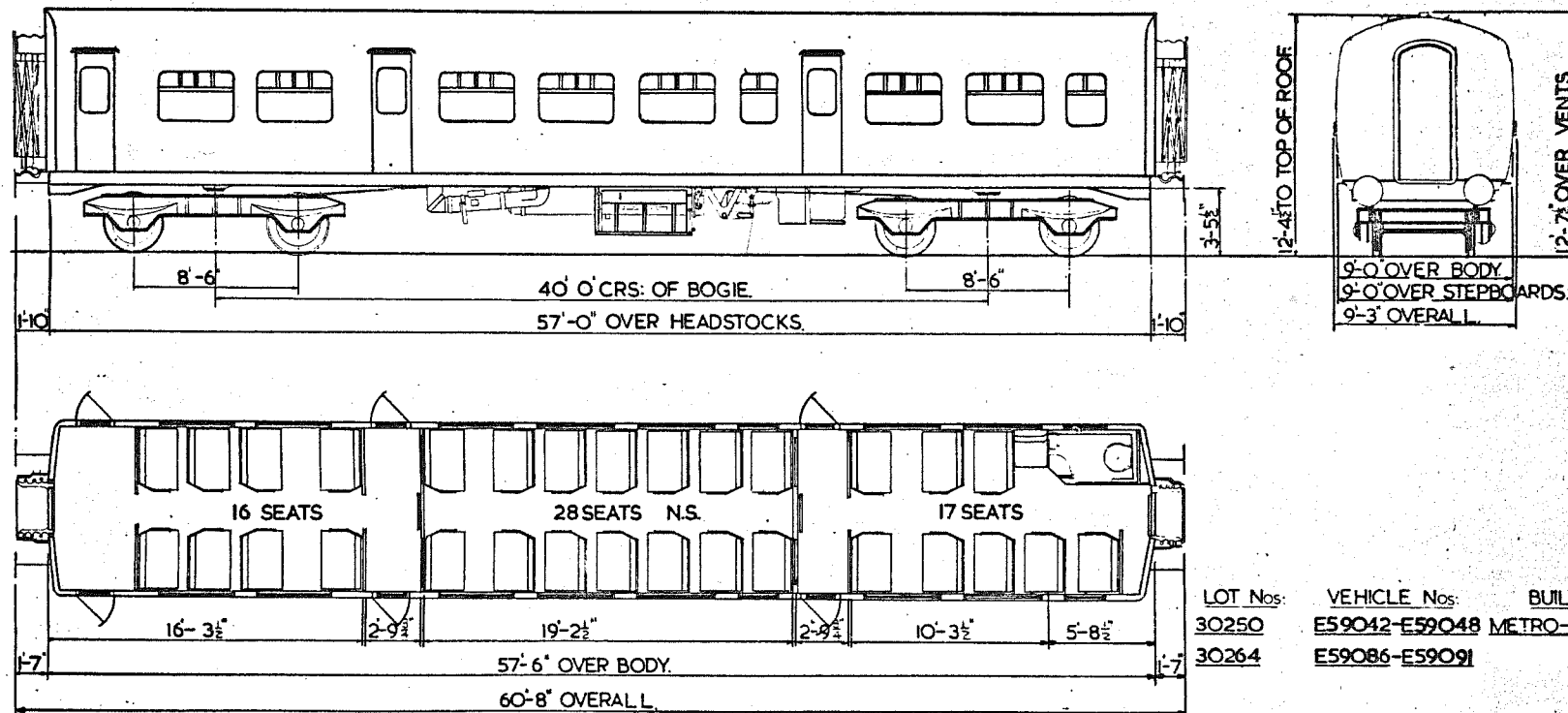

LOT Nos:	VEHICLE Nos:	BUILT BY:	TARE:
30250	E59042-E59048	METRO-CAMMELL	25T
30264	E59086-E59091		

3-SECOND 61 SEATS
 1-LAVATORY.

NS-NON SMOKING.

GANGWAYED TRAILER OPEN SECOND LAVATORY

B.R. 623

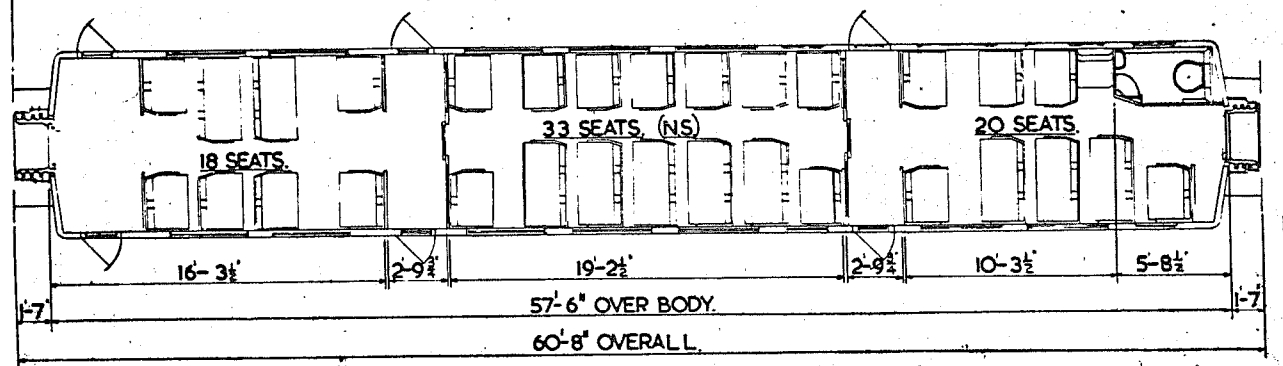
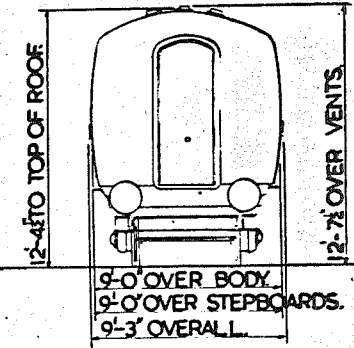
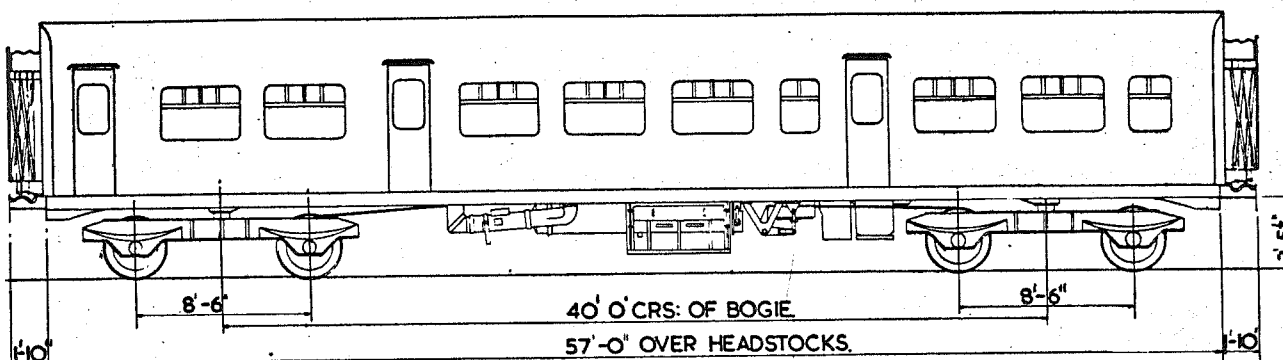

LOT Nos:	VEHICLE Nos:	BUILT BY:	TARE:
30257	E59060-	METRO-CAMMELL	25T
	E59072		
30269	E59100-		
	E59109		
30273	E59302-		
	E59306		
30510	E59569-		
	E59572		

3-SECOND 71 SEATS.
1-LAVATORY.

NS-NON SMOKING.

GANGWAYED TRAILER OPEN COMPOSITE LAVATORY

B.R. 624

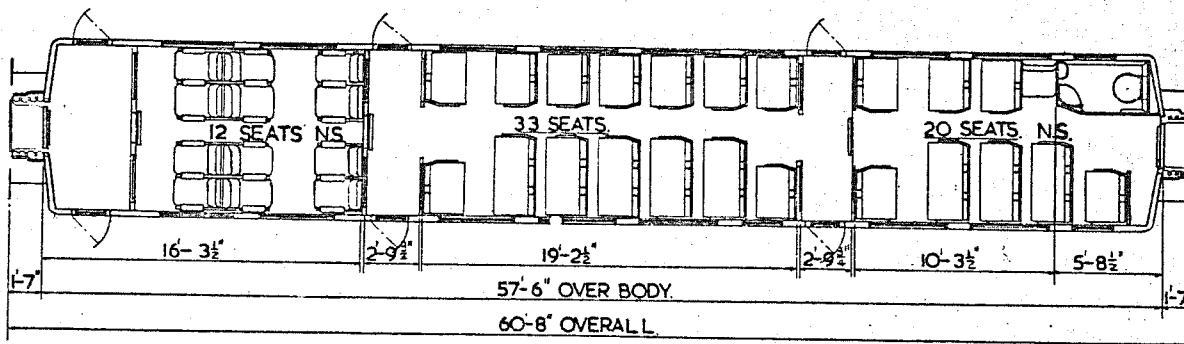
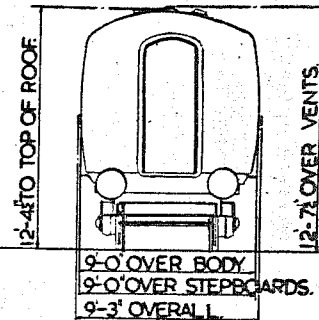
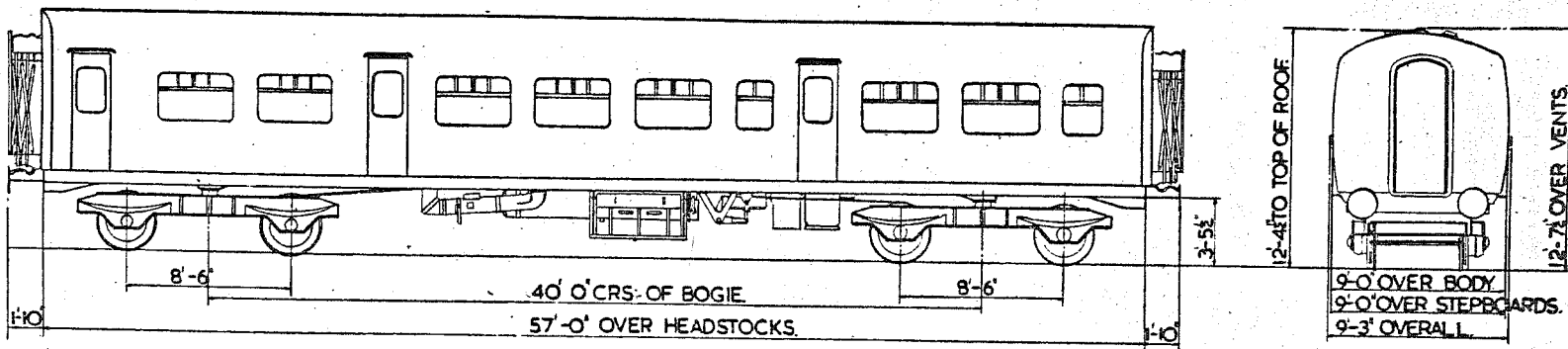

LOT Nos:	VEHICLE Nos:	BUILT BY:	TARE
30277	M.59114-M.59131	METRO-CAMMELL	25T
30502	E.59523-E.59542		
	SC.59543-SC.59568		
30589	SC.59686-SC.59692		

1-FIRST 12 SEATS
2-SECOND 53 SEATS
1-LAVATORY

NS-NON SMOKING

GANGWAYED TRAILER OPEN SECOND BUFFET LAVATORY

B.R. 625

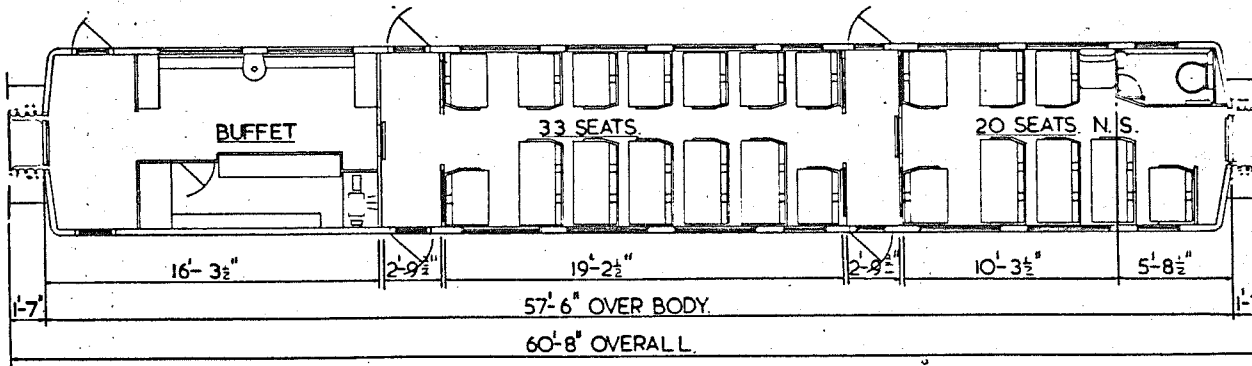
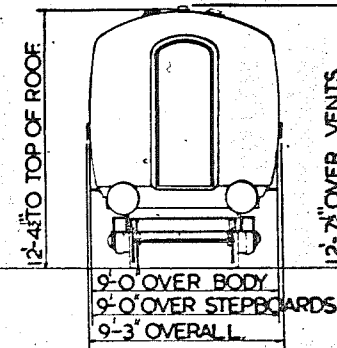
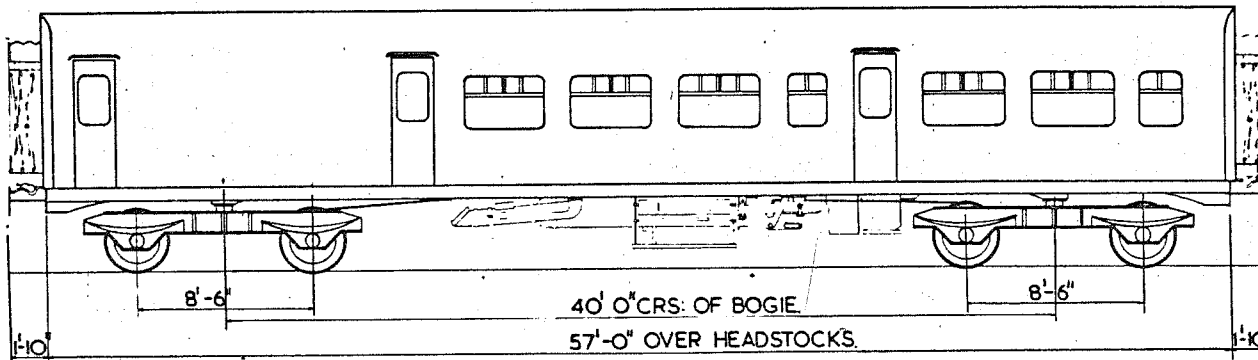

LOT Nos	VEHICLE Nos	BUILT BY	TARE
30615	E.59573 - E.59578	METRO-CAMMELL	25T

2-SECOND 53 SEATS
 1-LAVATORY
 1-BUFFET
 NS-NON SMOKING.

GANGWAYED TRAILER OPEN SECOND BRAKE

B.R. 626

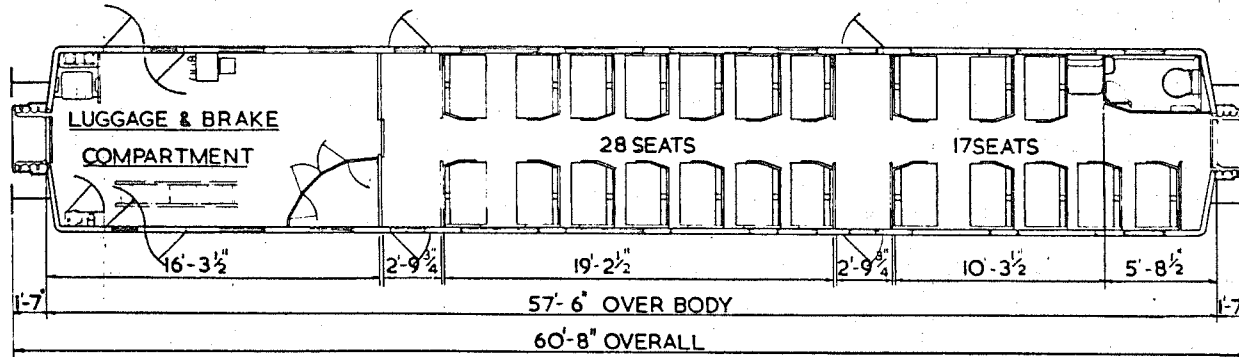
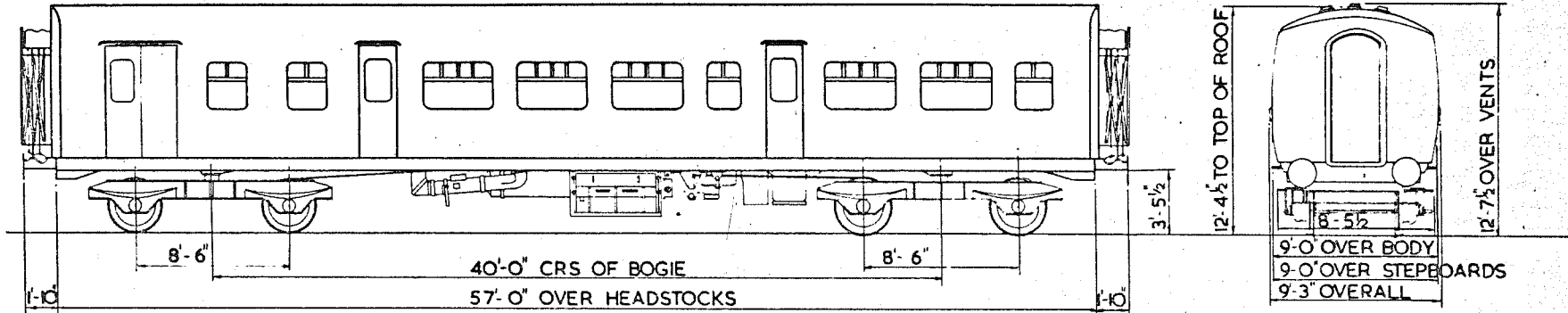

LOT Nos	VEHICLE Nos	BUILT BY	TARE
30251	E59049-E59055	METRO-CAMMELL	25 T
30265	E59092-E59097		

- 2 - SECOND 45 SEATS
- 1 - LUGGAGE COMPARTMENT
- 1 - LAVATORY

GANGWAYED TRAILER OPEN SECOND BRAKE

B.R. 627

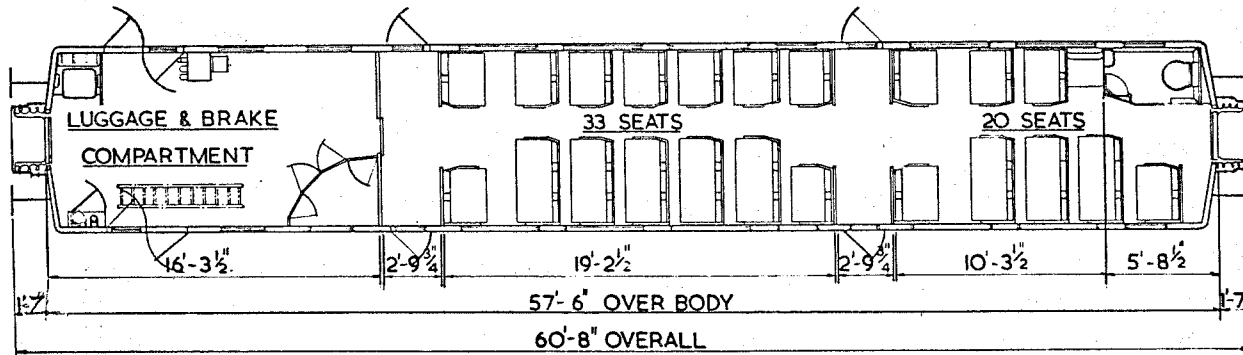
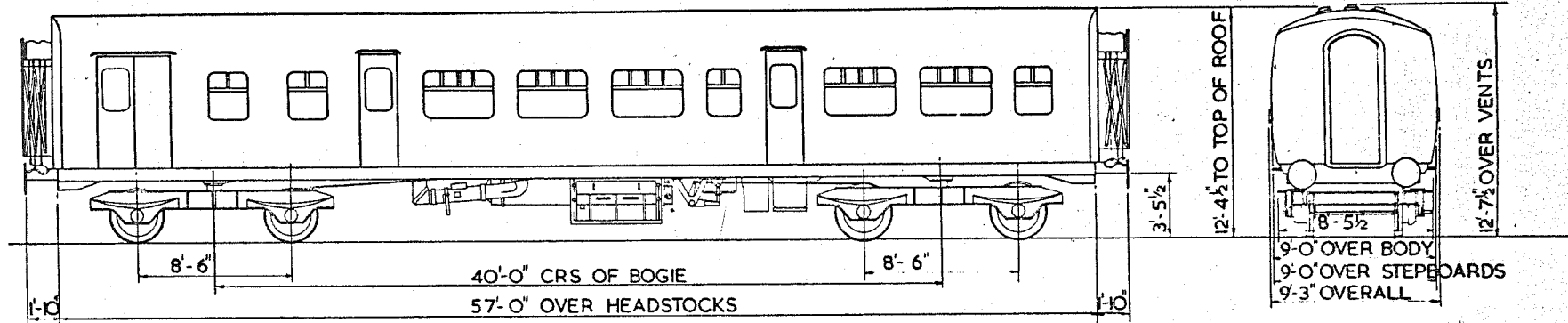

LOT Nos	VEHICLE Nos	BUILT BY	TARE
30258	E59073 - E59085	METRO-CAMMELL	25 T.
30274	E59112 E59113		

- 2 - SECOND 53 SEATS
 - 1 - LUGGAGE COMPARTMENT
 - 1 - LAVATORY
- Original © BRB Residuary Ltd

GANGWAYED DRIVING TRAILER OPEN COMPOSITE LAVATORY.

B. R. 628

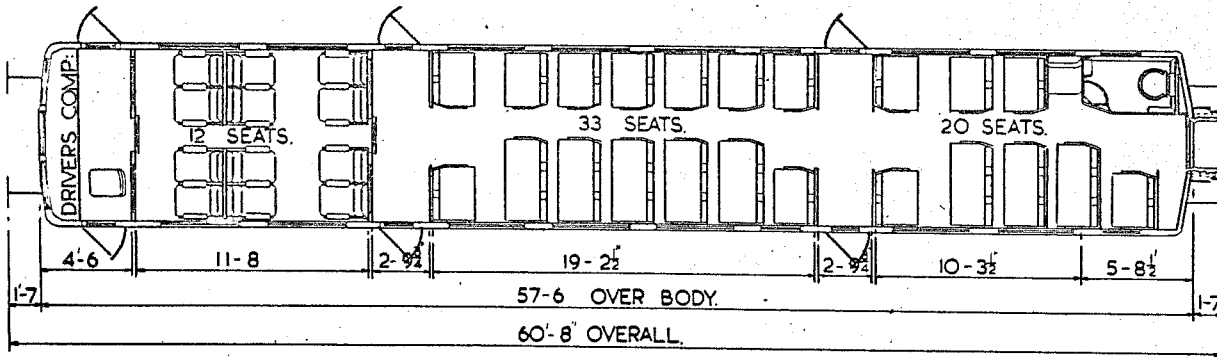
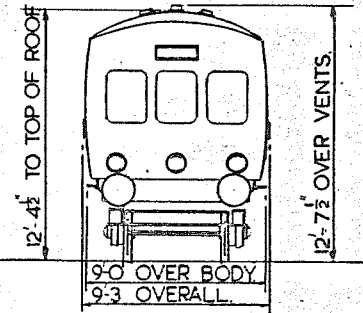
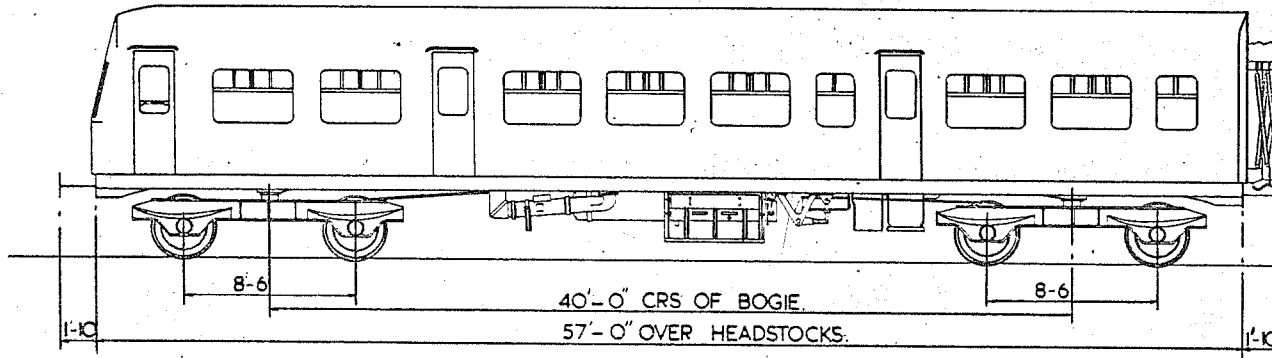

LOT Nos	VEHICLE Nos	BUILT BY	TARE
30337	M56090-M56093	METRO CAMMELL	25 T

- 1 FIRST 12 SEATS.
- 2 SECOND 33 SEATS.
- 1 DRIVERS COMPARTMENT.
- 1 LAVATORY.

GANGWAYED DRIVING TRAILER OPEN COMPOSITE LAVATORY

B.R. 629

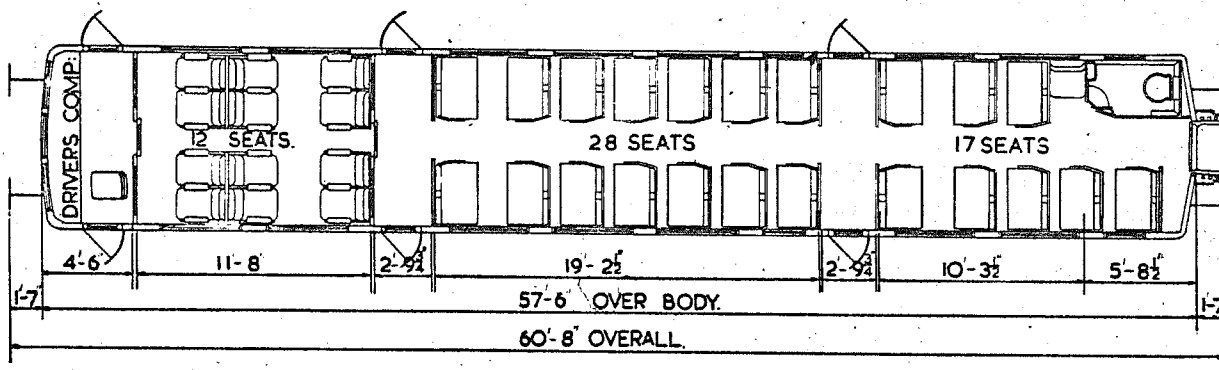
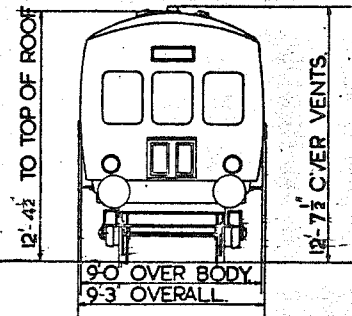
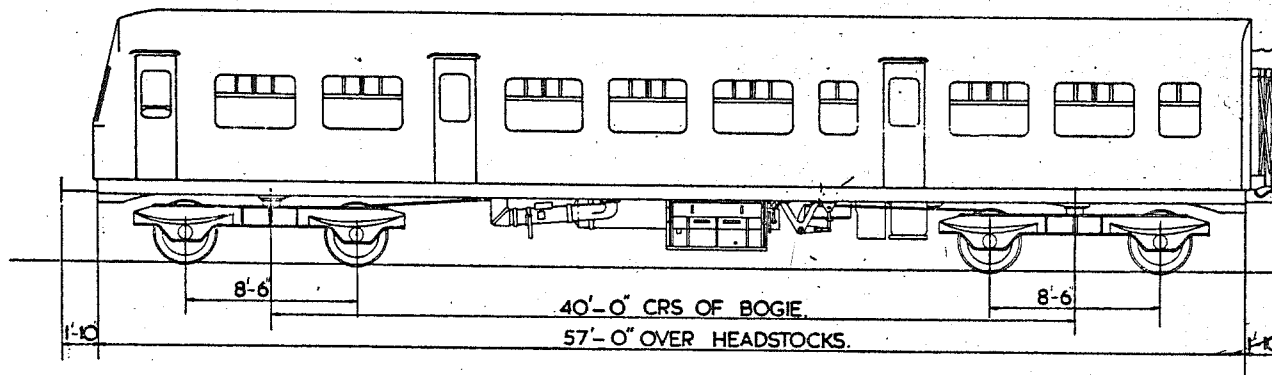

LOT Nos	VEHICLE Nos	BUILT BY	TARE
30340	E56218-E56220	METRO CAMMELL	25 T

- 1 FIRST 12 SEATS.
- 2 SECOND 45 SEATS.
- 1 DRIVER'S COMPARTMENT.
- 1 LAVATORY.

GANGWAYED DRIVING TRAILER OPEN COMPOSITE LAVATORY.

B.R. 630

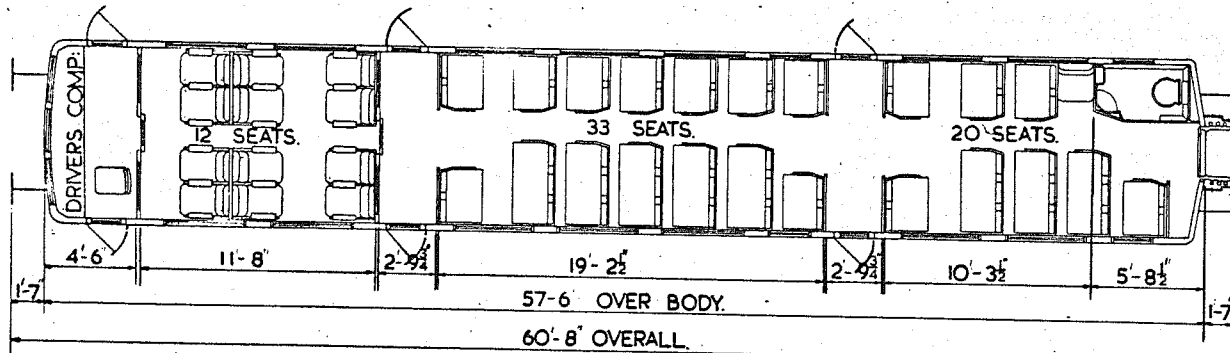
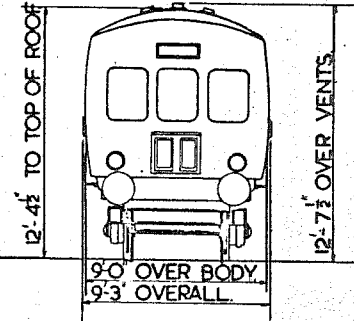
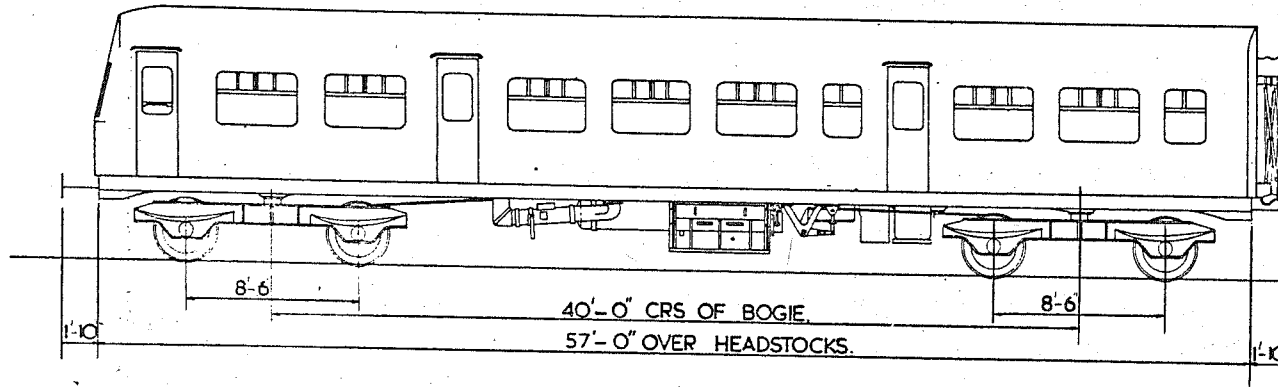

LOT Nos	VEHICLE Nos	BUILT BY	TARE
30260	E56050-E56061	METRO	25 T
30262	E56062-E56085	CAMMELL	
30272	E56086-E56089		
	M56332-M56361		
30468	E56362-E56381		
	SC56382-SC56411		

- 1 FIRST 12 SEATS.
- 2 SECOND 53 SEATS.
- 1 DRIVERS COMPARTMENT.
- 1 LAVATORY.

GANGWAYED DRIVING TRAILER LAVATORY COMPOSITE.

B.R. 631.

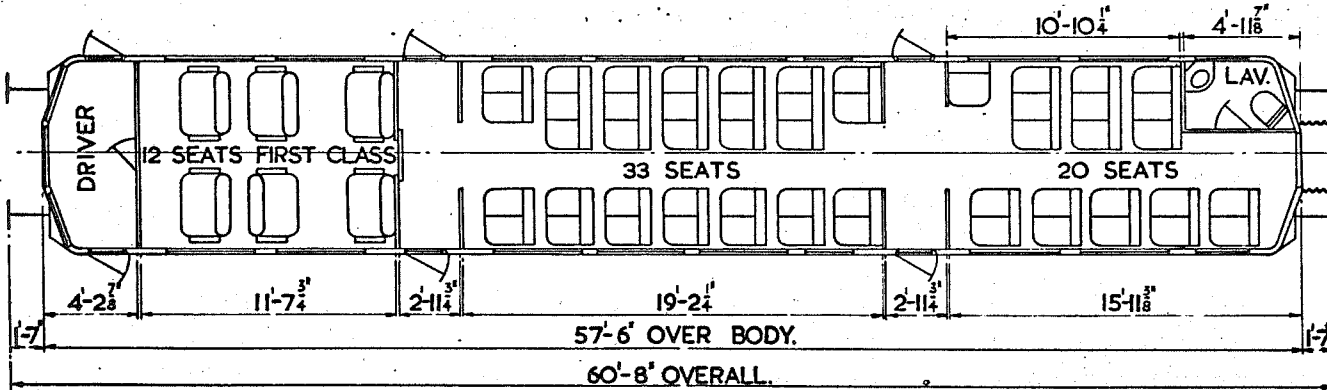
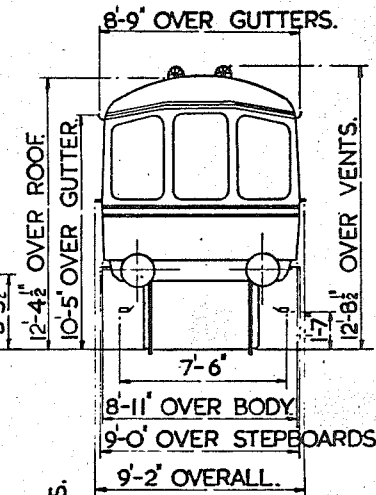
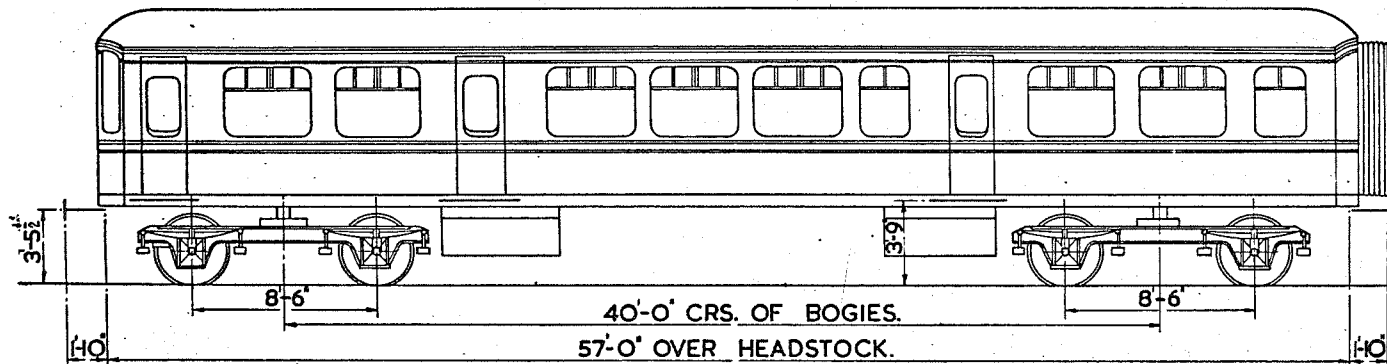

5'-8 1/2"
CRS. OF BUFFERS.

QTY.	LOT.	VEHICLE NOS.	BUILT AT	TARE
4	30241	E79658-E79661	DERBY	21T.

- 1 FIRST - 12 SEATS.
- 2 SECOND - 53 SEATS.
- 1 DRIVING COMPARTMENT.
- 1 LAVATORY.

GANGWAYED MOTOR OPEN SECOND BRAKE

B.R. 632.

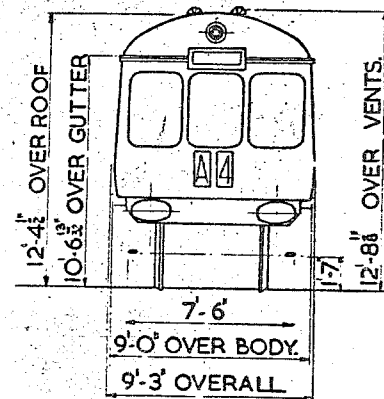
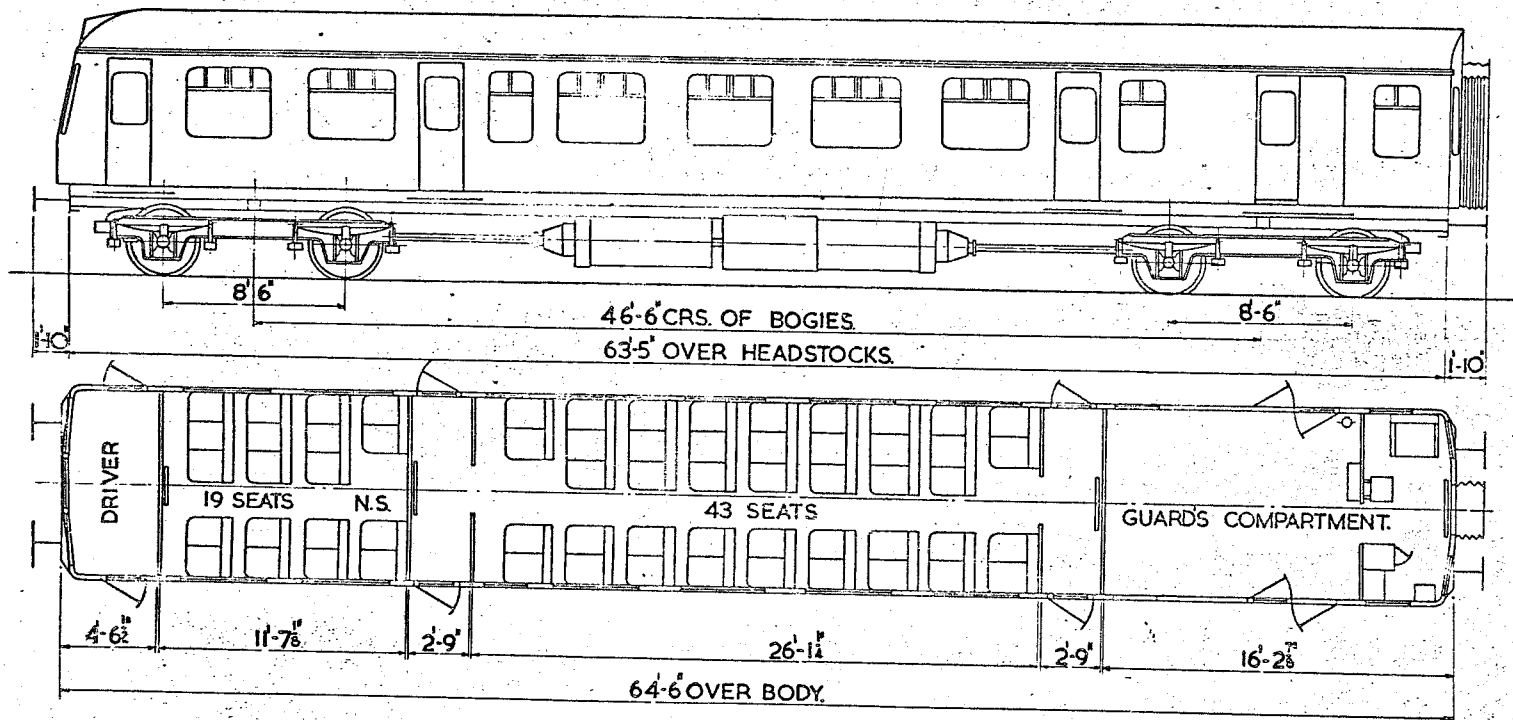

N.S. NON SMOKING

2 SECOND. 62 SEATS.
 1. GUARD & LUGGAGE.
 1 DRIVING.

2X 23E RR. ENGINES

LOT. No. VE. E. No.
 30341. E. 50000.

BUILT AT TARE.
 DERBY 41T.3C.

GANGWAYED MOTOR OPEN SECOND BRAKE

B.R. 633

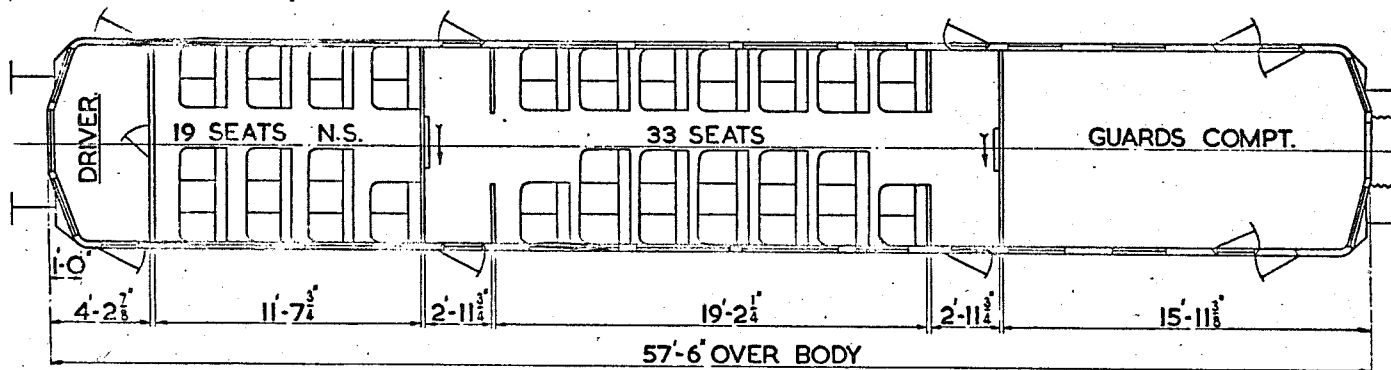
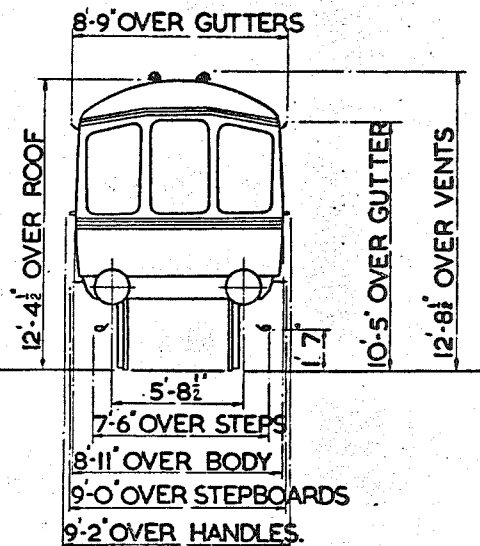
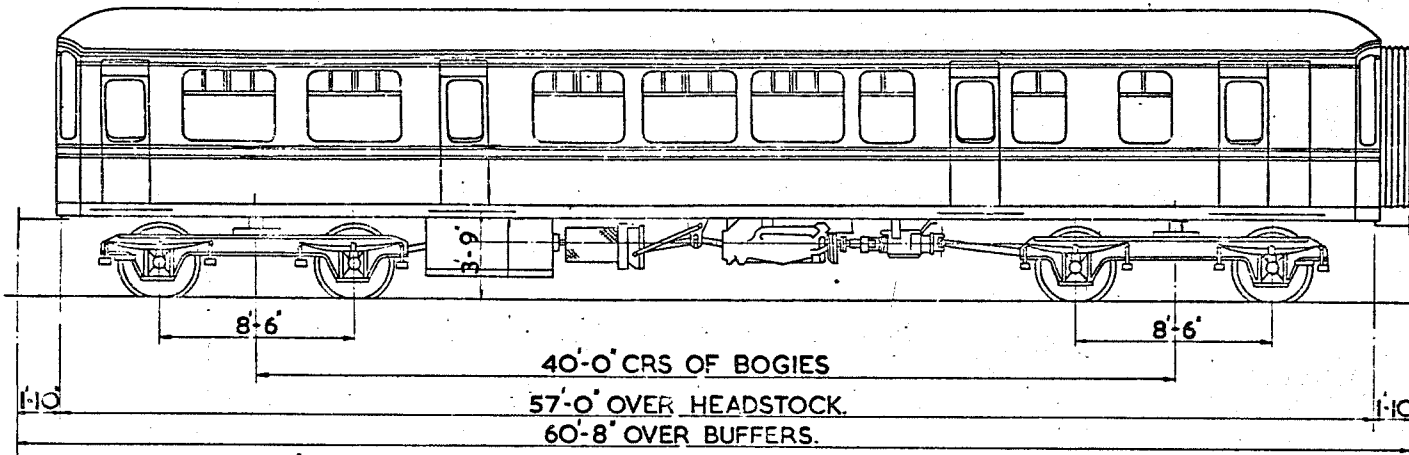

N.S. - NON SMOKING

QTY.	LOT.	TARE	BUILT AT	VEHICLE NO
7	30201	27 T.	DERBY	M 79143-79149
9	30235	27 T.	DERBY	M 79118 - 79126
10	30240	27 T.	DERBY	M 79127- 79136
2	30246	27 T.	DERBY	M 79141- 79142
13	30321	27 T.	DERBY	M 79169- 79181
5	30324	27 T.	DERBY	M 79184-79188

2 SECONDS - 52 SEATS

2 X 150 H.P. ENGINES

1 DRIVING COMPT.

1 GUARD & LUGGAGE COMPT.

Original © BRB Residuary Ltd

Original diagrams courtesy of Clive Mortimore. This PDF copy by J.D. Faulkner, 2010

(visit <http://www.barrowmoremr.com>)

GANGWAYED MOTOR OPEN SECOND BRAKE

B.R. 634

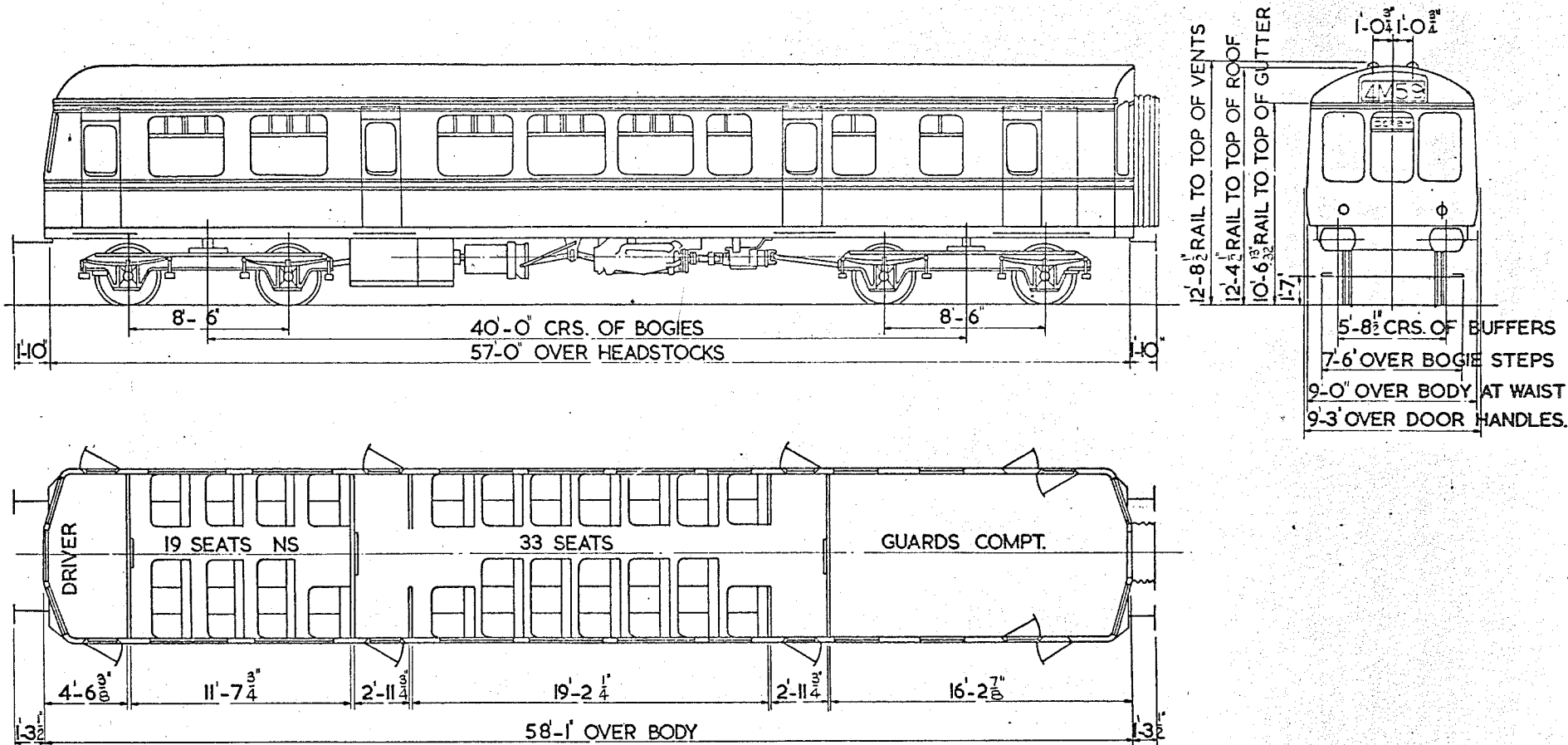

2 SECOND 52 SEATS
 1 DRIVING COMPARTMENT
 1 GUARD & LUGGAGE

2 x 150 ^{HP} BUT. ENGINES

LOT No.

VEHICLE No.

BUILT AT

TARE

30498

M5141-M51424

DERBY

29 T

30601

M51901-M51950

DERBY

29 T

GANGWAYED MOTOR OPEN SECOND BRAKE

B.R. 635.

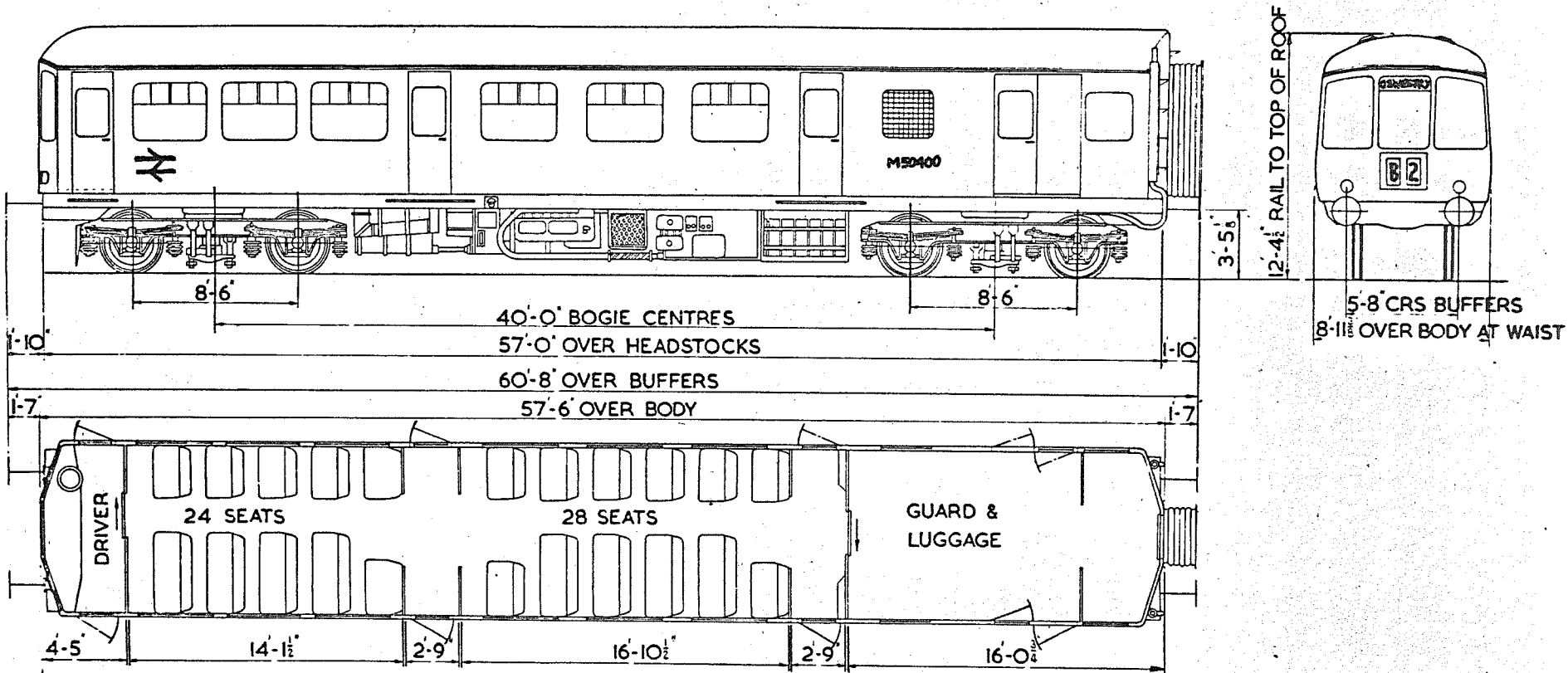

2 SECOND 52 SEATS
 1 DRIVING COMPARTMENT
 1 GUARD & LUGGAGE

2 X 150 H.P. B.U.T. ENGINES

QTY	LOT No.	VEHICLE Nos.	BUILT AT	TARE
20	3C 6	M50395-M50414	B.U.T.	33 1/2 T.

GANGWAYED MOTOR OPEN COMPOSITE BRAKE.

B.R. 636

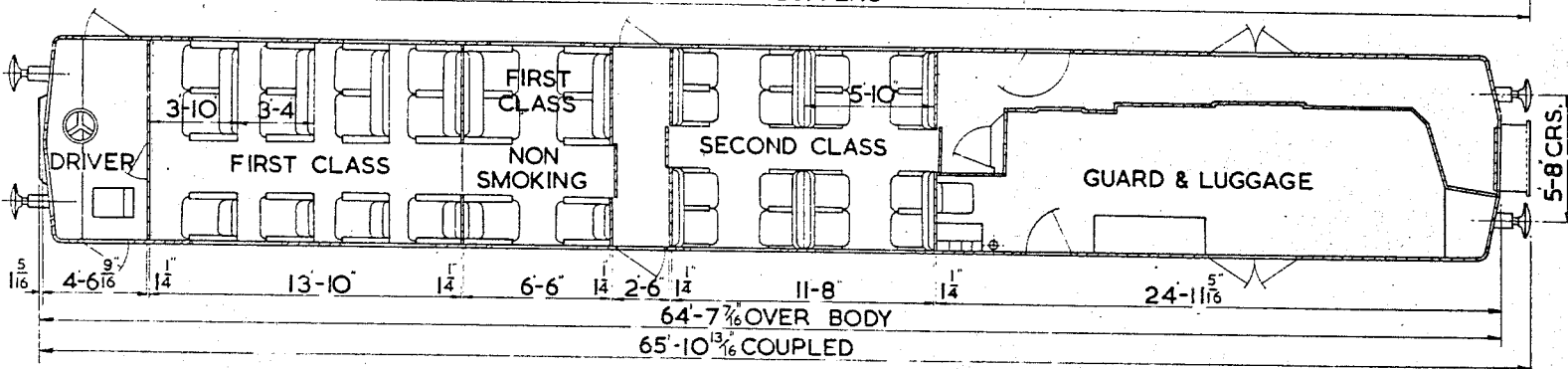
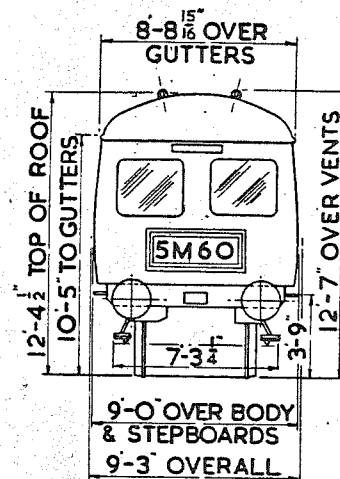
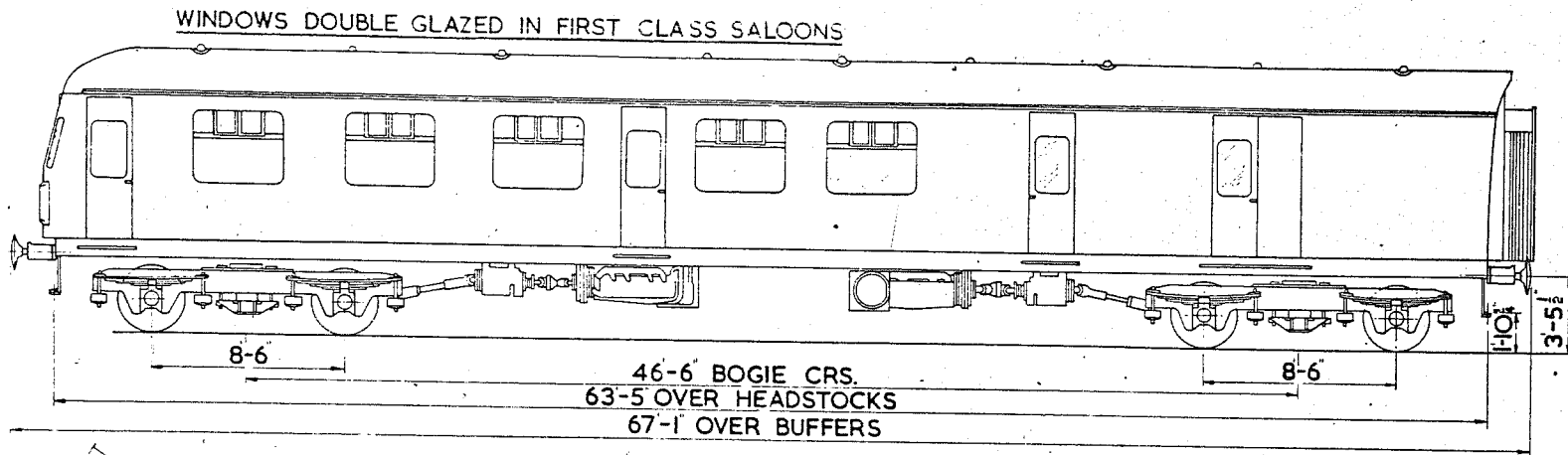

QTY.	LOT.	TARE TONS.CWTS.	BUILT AT.
9	30515	36 - 19	SWINDON

- 2 FIRST 18 SEATS
- 1 SECOND 16 SEATS
- 1 DRIVING COMPT.
- 1 GUARD & LUGGAGE COMPT.

2x150 H.P. B.U.T. ENGINES.



B.R. 637

GANGWAYED MOTOR OPEN SECOND.

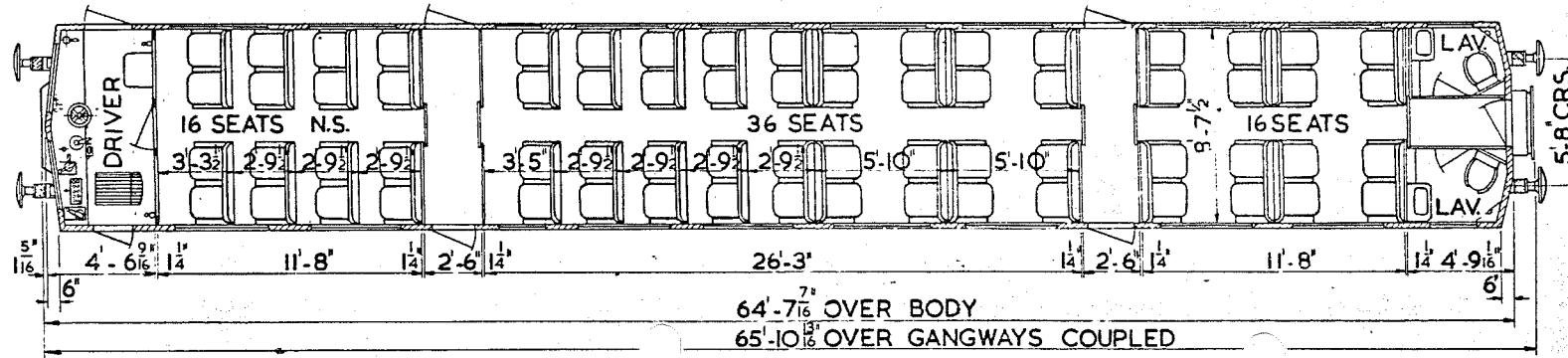
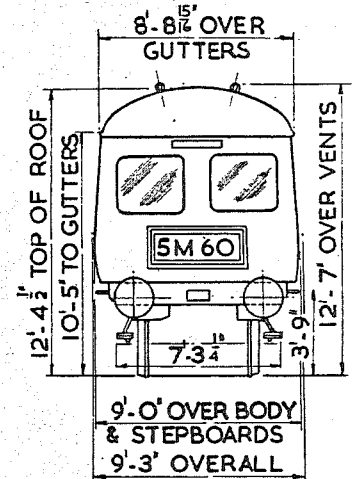
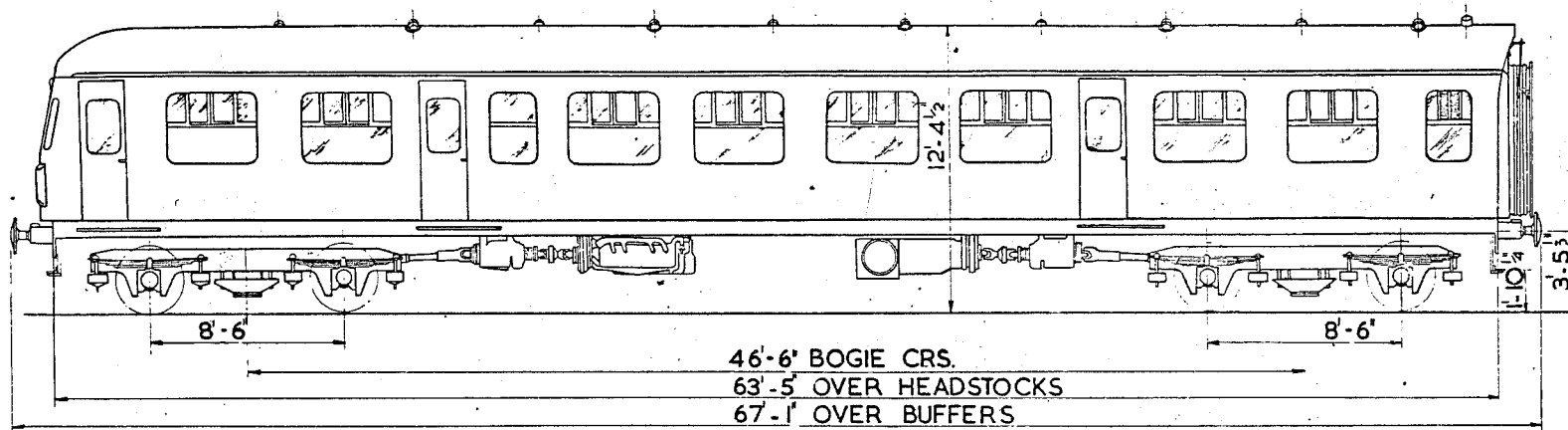

		TARE		BUILT AT
QTY.	LOT.	TONS.	CWTS.	
9	30516	37	- 1	SWINDON

NS. NON SMOKING



SECOND CLASS 68 SEATS

MOTOR'S 1 DRIVING COMPT

Original © BRB Residuary Ltd

Original diagrams courtesy of Clive Mortimore. This PDF copy by J.D. Faulkner, 2010

(visit <http://www.barrowmoremr.com>)

GANGWAYED MOTOR OPEN LAVATORY COMPOSITE

B.R 638

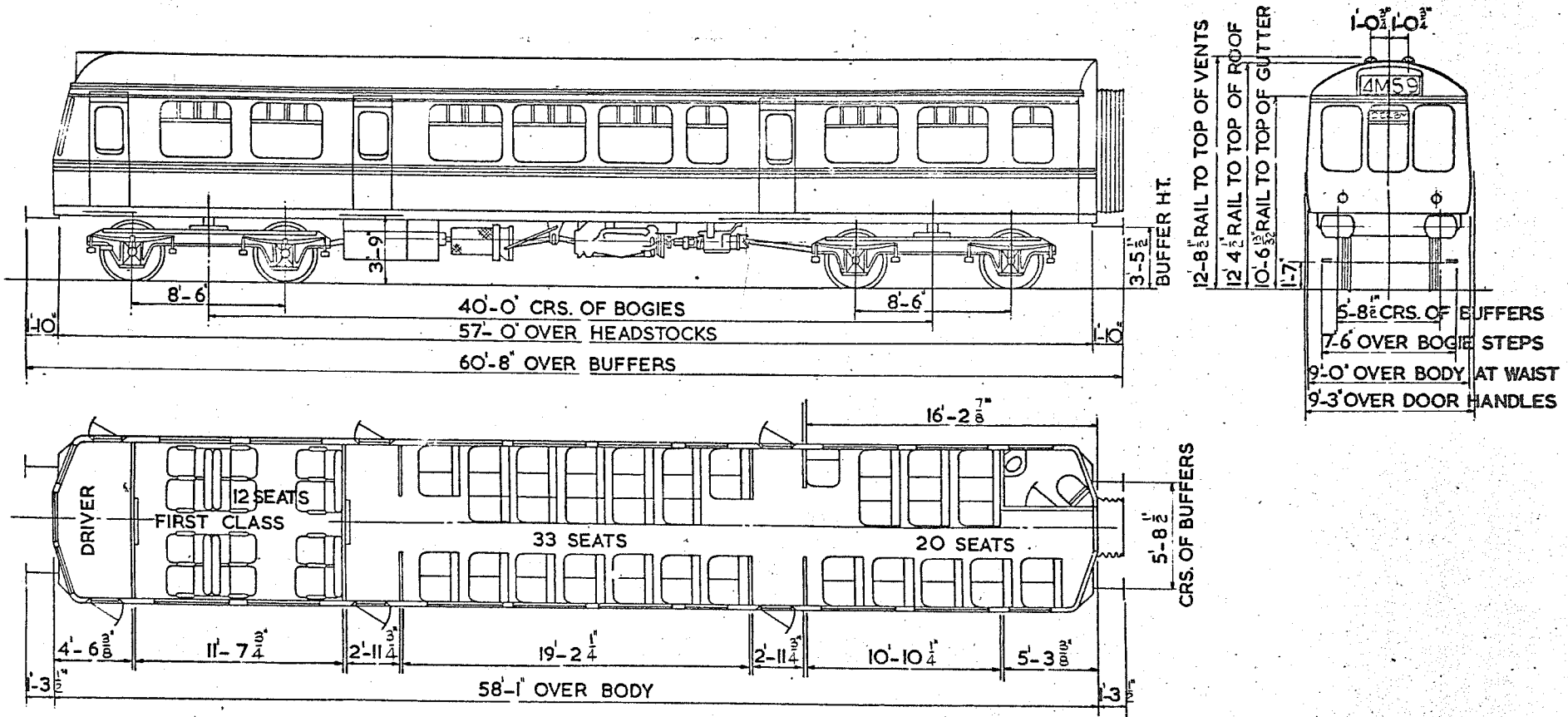

1 FIRST 12 SEATS

2 x 150 H.P. B.U.T. ENGINES

LOT No.

VEHICLE No.

BUILT AT

TARE

2 SECOND 53 SEATS

30660

M52037-M52035

DERBY

28 T

1 LAVATORY COMPT.

1 DRIVING COMPT.

Original © BRB Residuary Ltd

Original diagrams courtesy of Clive Mortimore. This PDF copy by J.D. Faulkner, 2010

(visit <http://www.barrowmoremr.com>)

157%

GANGWAYED MOTOR OPEN SECOND BRAKE

B.R. 639

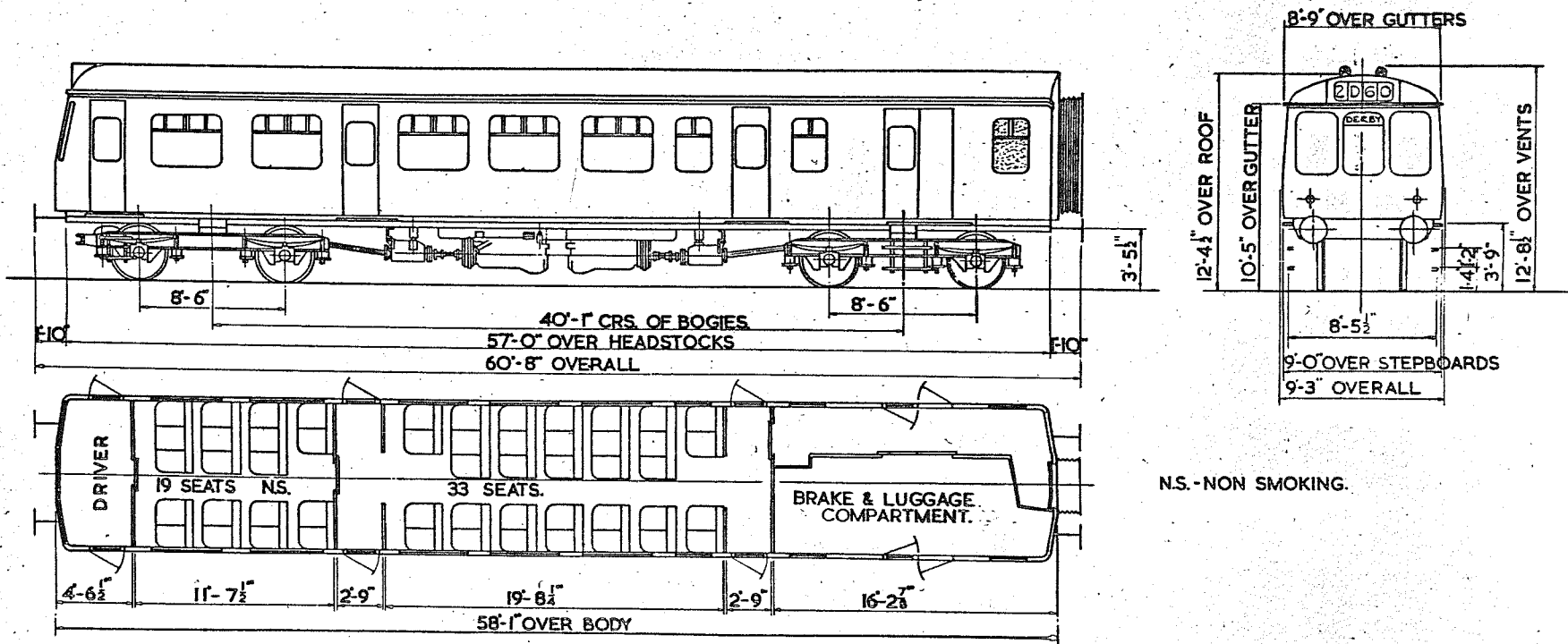

N.S. - NON SMOKING.

2 SECONDS 52 SEATS.
 1 DRIVING COMPARTMENT
 1 GUARD & LUGGAGE COMPARTMENT.

2 X 150 H.P. B.U.T. ENGINES

QTY. 1 VEHICLE NoS.
 26 3000 Sc.51985-Sc.52010

BUILT AT TARE
 DERBY 34 1/2 TONS

GANGWAYED DRIVING TRAILER LAVATORY COMPOSITE.

B.R. 640

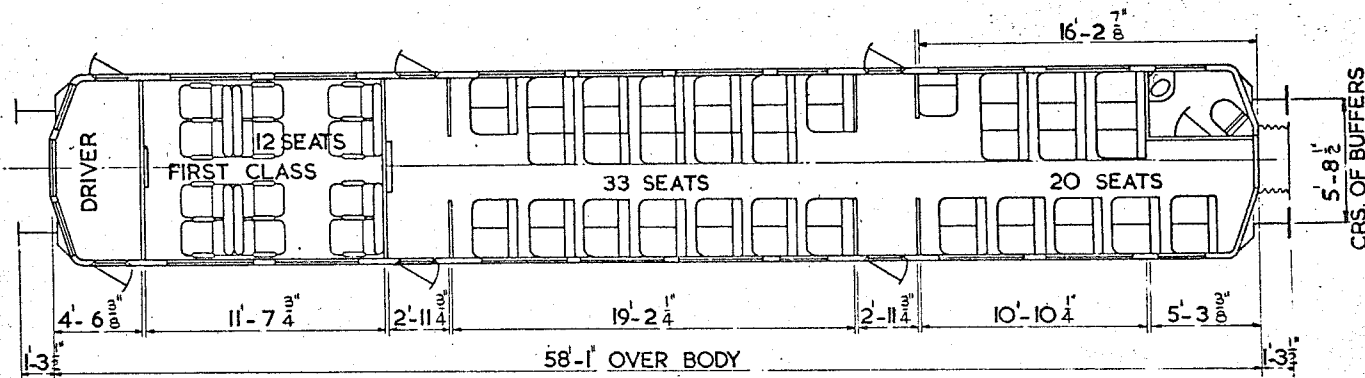
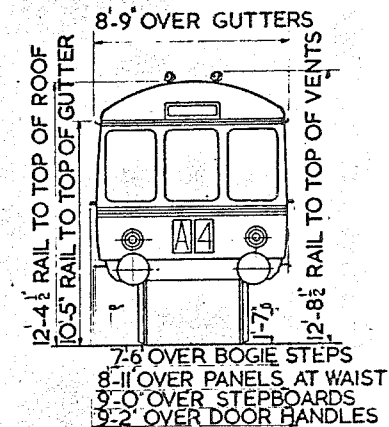
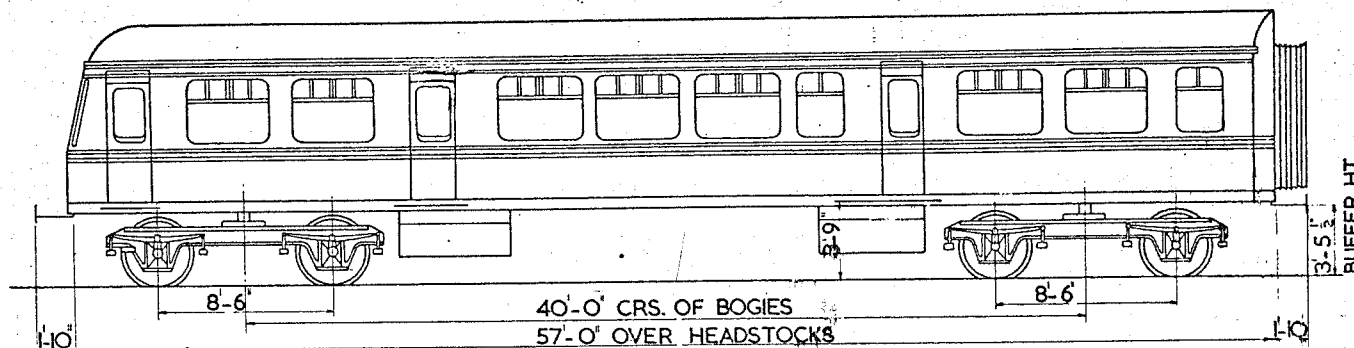

- 1 FIRST 12 SEATS
- 2 SECOND 53 SEATS
- 1 LAVATORY COMPT.
- 1 DRIVING COMPT.

LOT No.	VEHICLE No	BUILT AT	TARE
30409	E 56190-E56210	DERBY	21 T
30410	M56211-M56215	DERBY	21 T
30466	M56221-M56270	DERBY	21 T

GANGWAYED DRIVING TRAILER LAVATORY COMPOSITE.

B.R. 641.

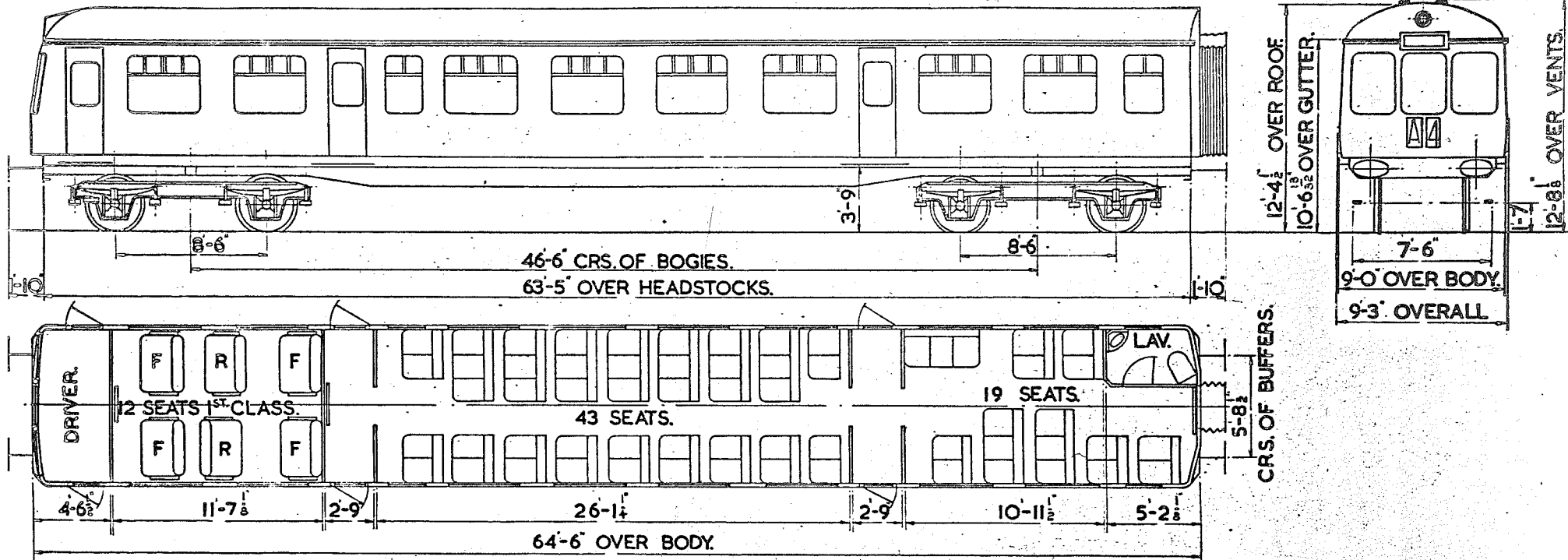

- 1 FIRST 12 SEATS.
- 2 SECOND 62 SEATS.
- 1 LAVATORY.
- 1 DRIVING COMPARTMENT

F- FIXED SEATS.
 R- REVERSIBLE SEATS.

LOT Nos.	VEHICLE Nos.	BUILT AT.	TARE
30210.	E 56001-56049	DERBY.	29 T. 10 C.
30342	E56000.	DERBY	31 T. 3 C.

GANGWAYED DRIVING TRAILER LAVATORY COMPOSITE.

B.R. 642

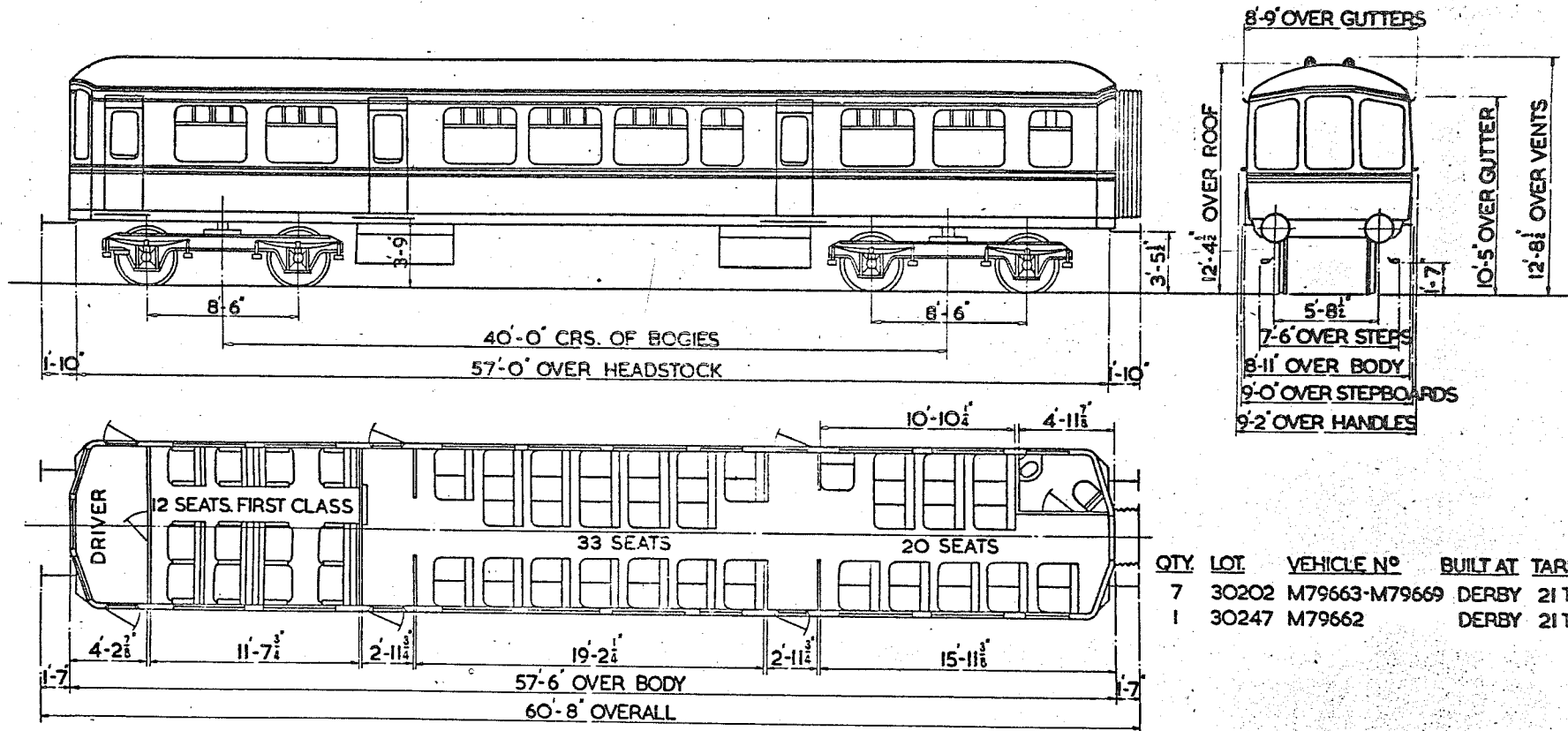

- 1 FIRST - 12 SEATS
- 2 SECOND - 53 SEATS
- 1 DRIVING COMPARTMENT
- 1 LAVATORY

GANGWAYED MOTOR PARCELS VAN

B.R. 643

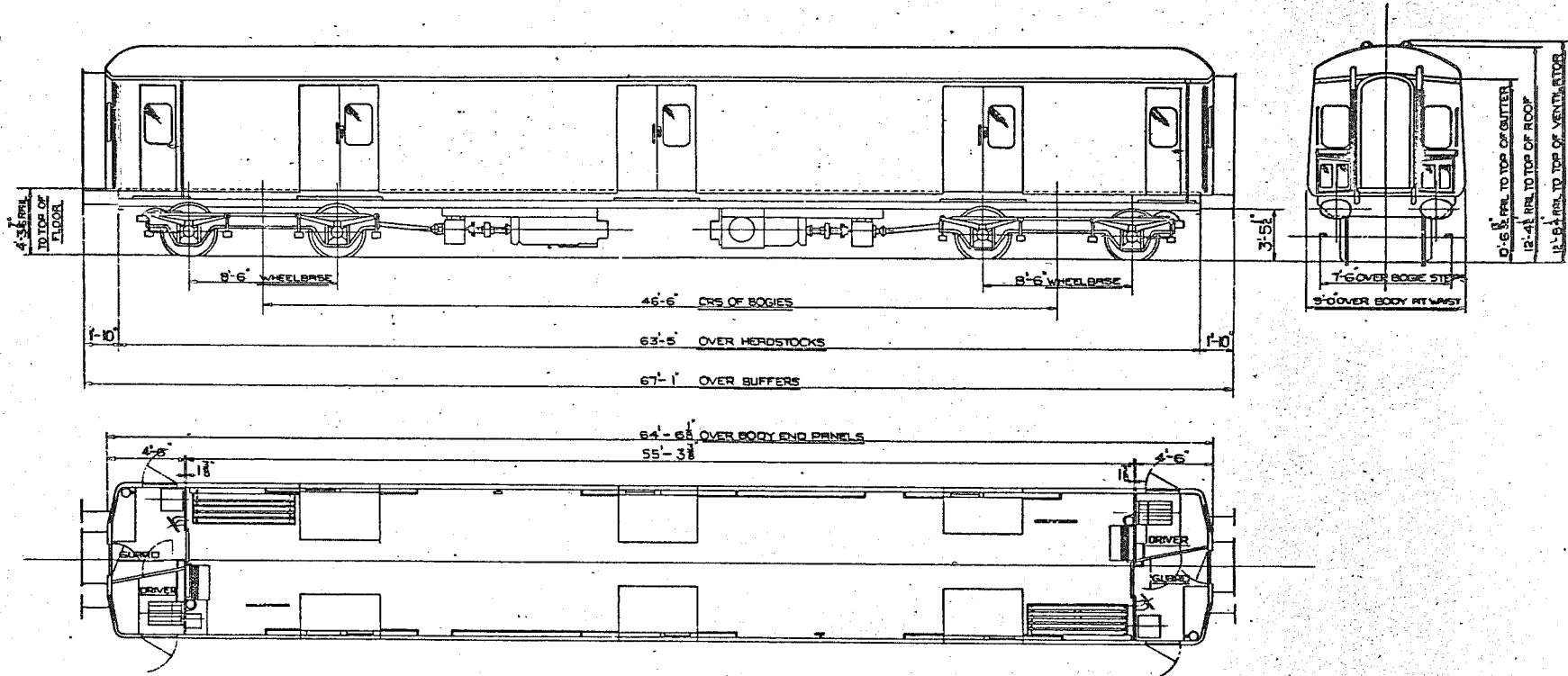

2 DRIVING COMPARTMENT
 2 GUARD COMPARTMENTS
 1 LUGGAGE COMPARTMENT

2 X 238 H.P. BUT. ENGINES

LOT NO

VEHICLE NOS

BUILDER

TARE

305

W55991 - W55996

GLOUCESTER RLY CARR. & W.C.

41 TONS

NON GANGWAYED MOTOR PARCELS VAN

B.R. 644

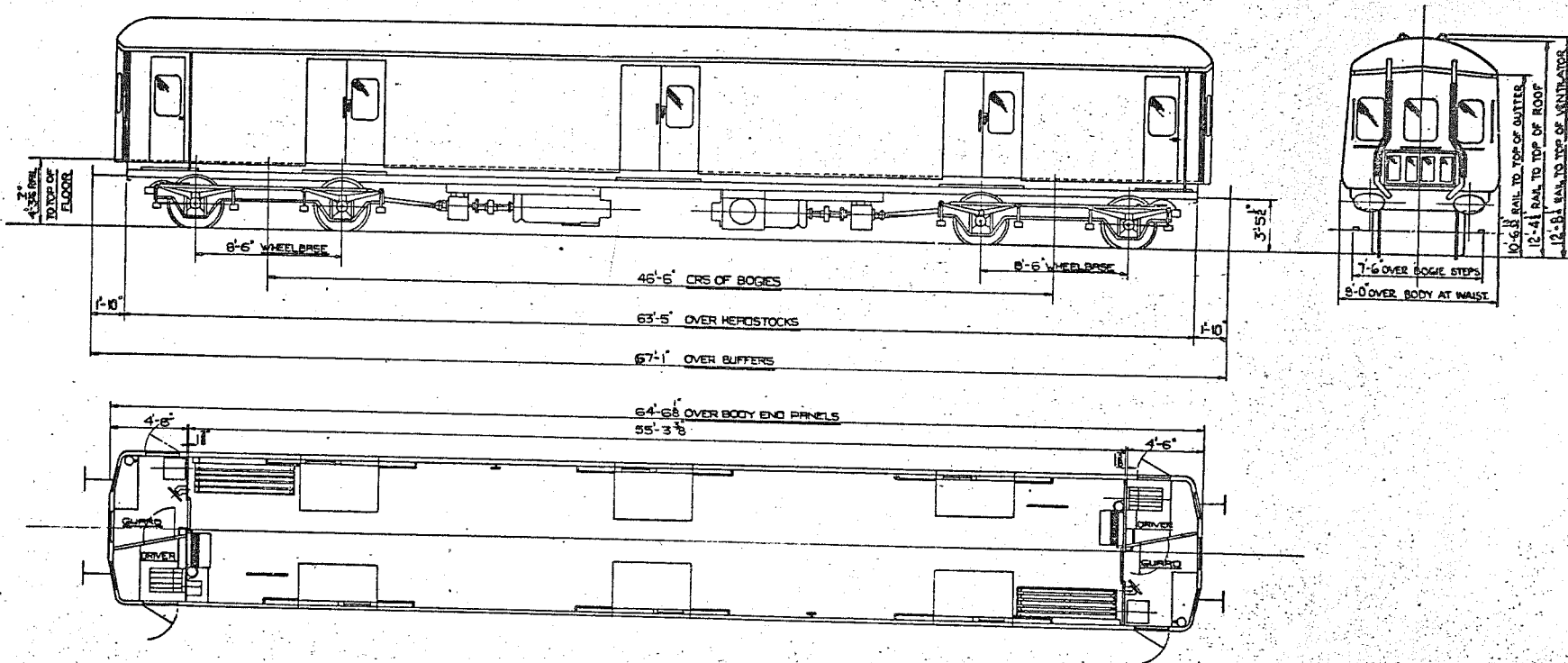

2 DRIVING COMPARTMENTS
2 GUARD COMPARTMENTS
1 LUGGAGE COMPARTMENT

LOT NO

30552

VEHICLE NOS

M55987-M55990

BUILDER

GLoucester Rly CARR & W.C. CO

TARE

40 TONS

2 X 238 H.P. BUT. ENGINES

GANGWAYED DRIVING TRAILER LAVATORY COMPOSITE.

B.R. 645.

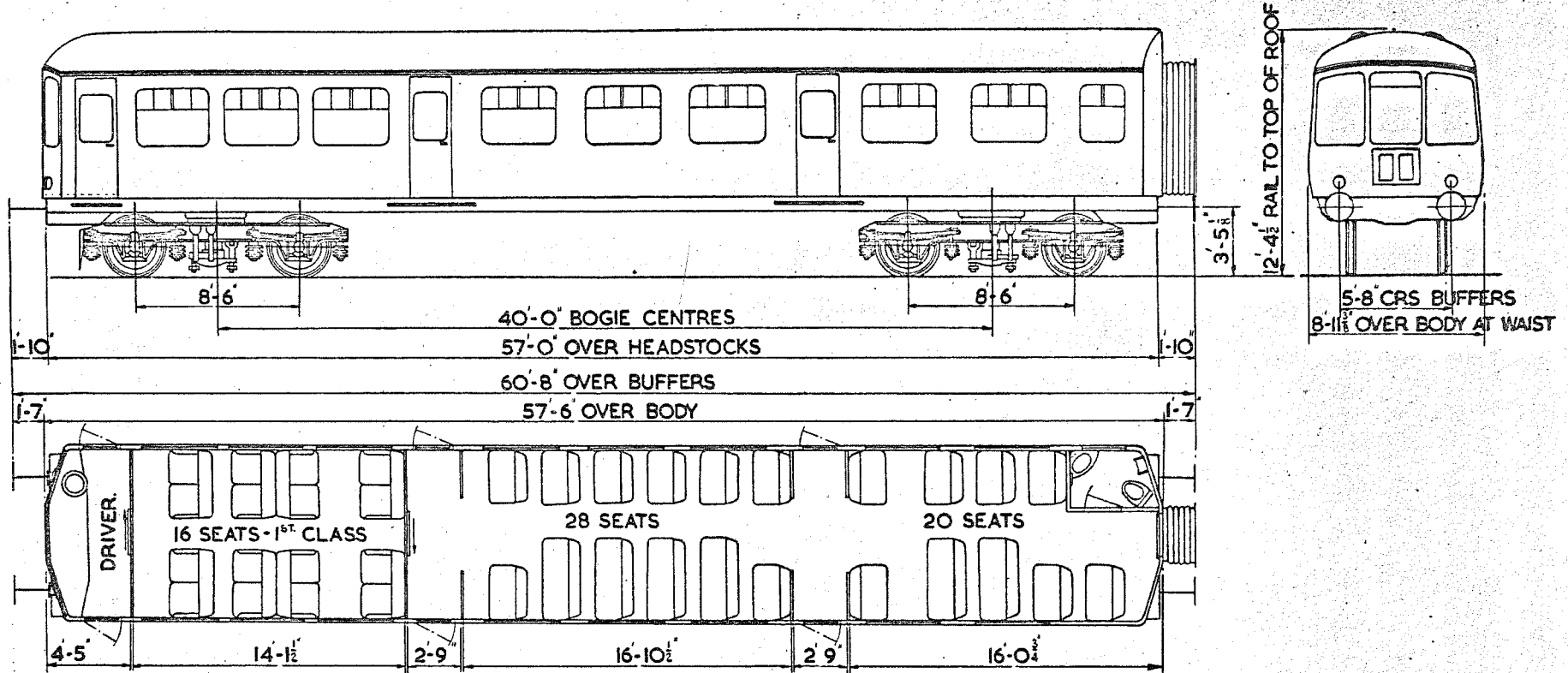

- 1 FIRST 16 SEATS
- 2 SECOND 48 SEATS
- 1 DRIVING COMPARTMENT
- 1 LAVATORY

QTY.	LOT No.	VEHICLE Nos.	BUILT AT	TARE
20	30287	M56150-M56169.	B.U.T.	26 1/2 T.

GANGWAYED DRIVING TRAILER LAVATORY COMPOSITE.

B.R. 646.

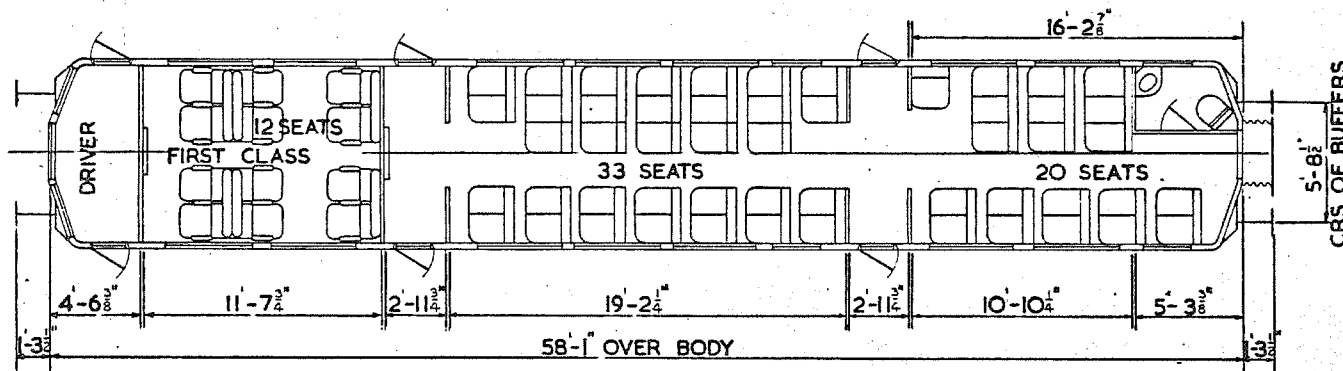
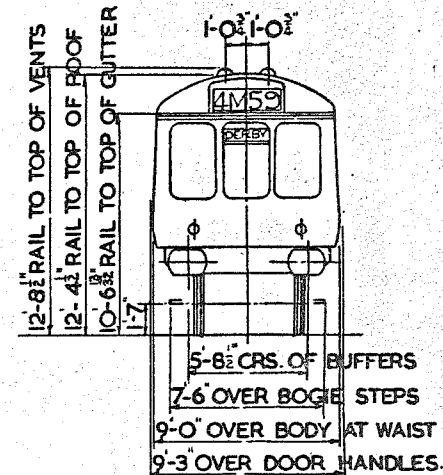
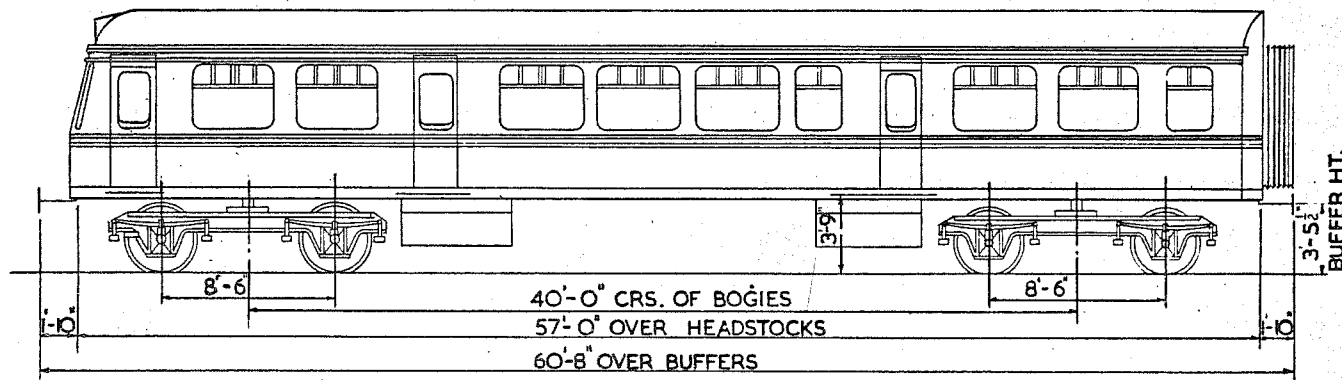

- 1 FIRST 12 SEATS
- 2 SECOND 53 SEATS
- 1 LAVATORY COMPT.
- 1 DRIVING COMPT.

LOT No	VEHICLE No	BUILT AT	TARE
30499	M56271 -M56279	DERBY	22T
30602	M56484-M56504	DERBY	22T

GANGWAYED TRAILER OPEN LAVATORY SECOND

B.R. 647

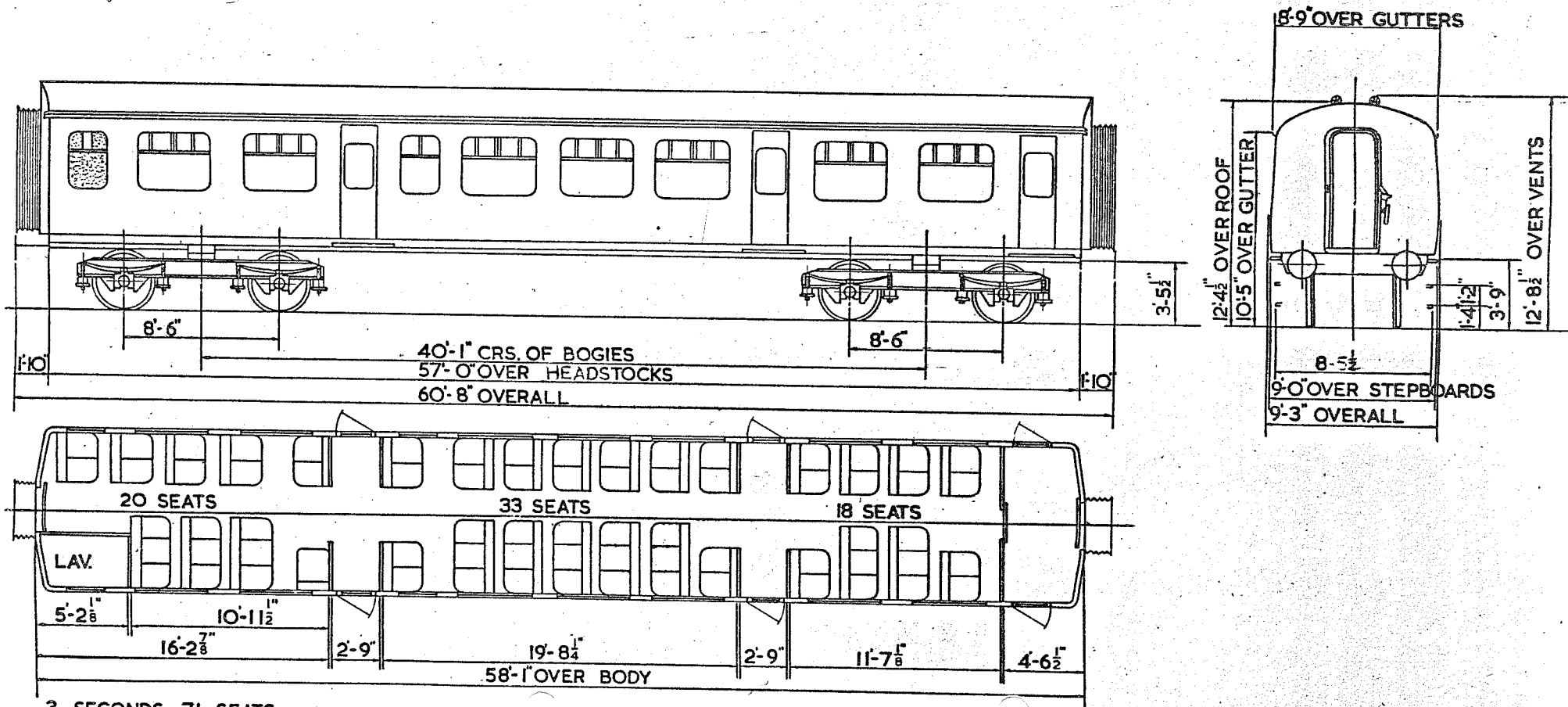

3 SECONDS 71 SEATS
1 LAVATORY

<u>QTY</u>	<u>LOI</u>	<u>VEHICLE NoS.</u>	<u>BUILT AT</u>	<u>TARE</u>
26	30613	Sc59782-Sc59807	DERBY	28 TONS

GANGWAYED TRAILER OPEN SECOND LAVATORY

B.R 648.

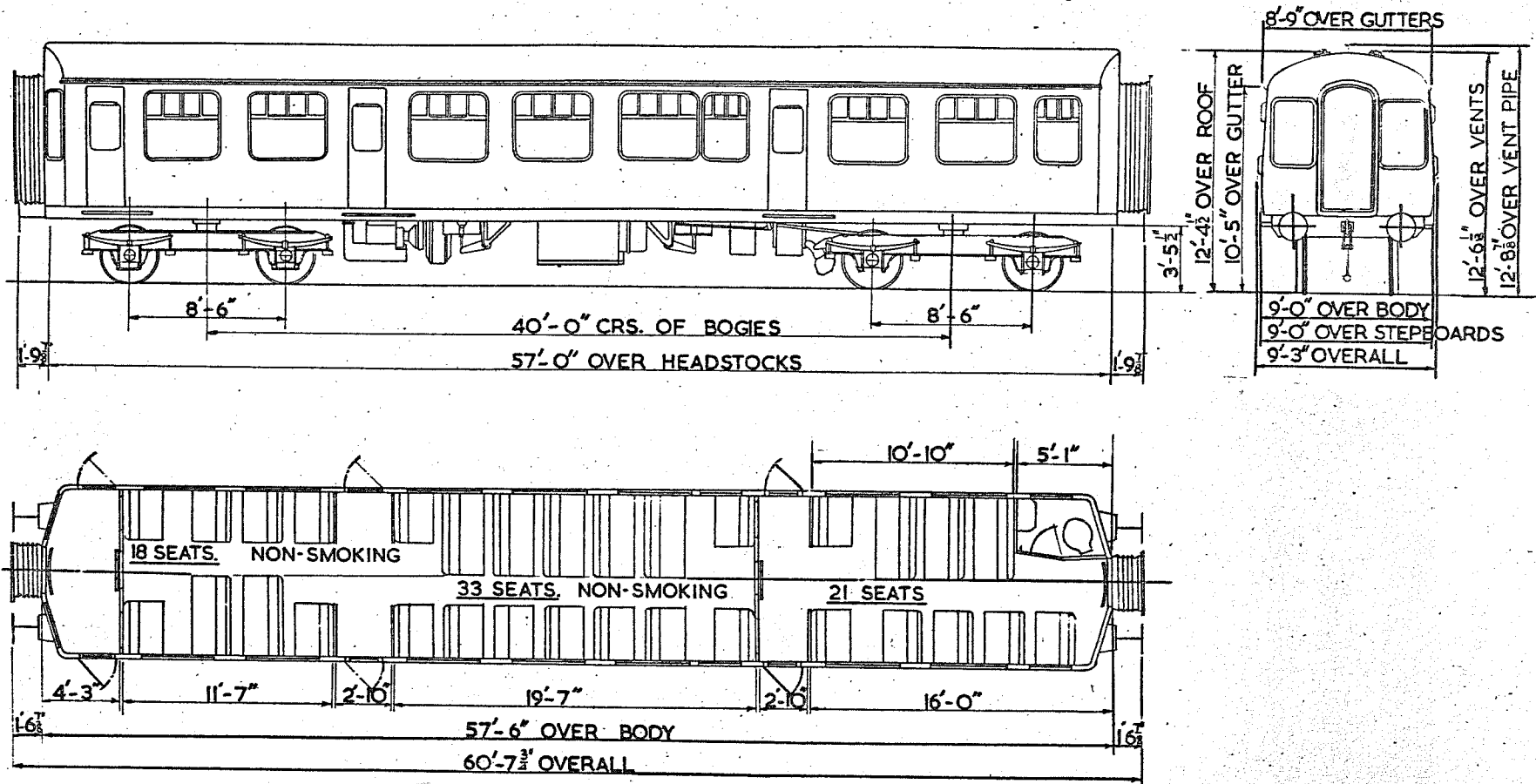

3 SECOND. 72 SEATS
1 LAVATORY

LOT No. 30594 VEHICLE NoS E59693-E5972

BUILT AT BIRM'H.M. RLY. C & W. Co. TARE

GANGWAYED MOTOR OPEN LAVATORY COMPOSITE

B. R. 649

140%

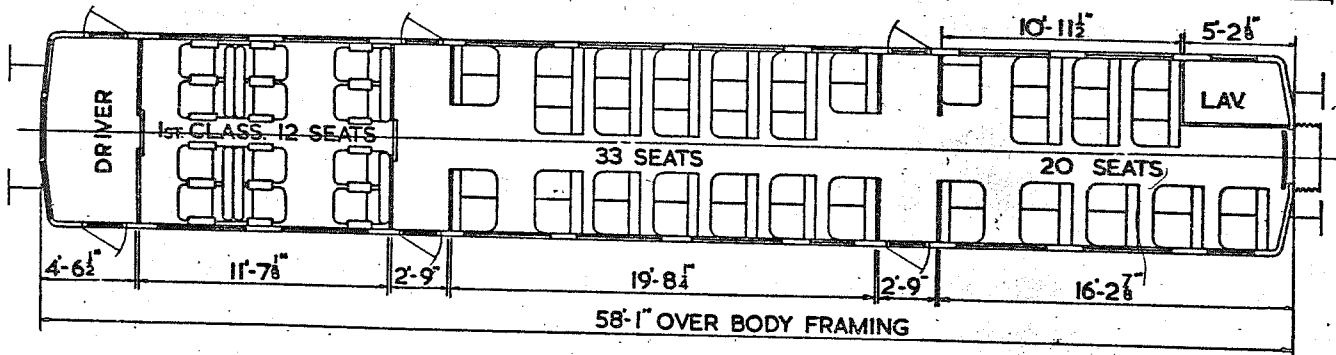
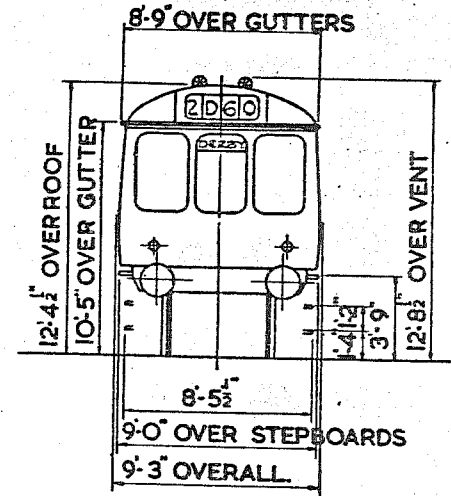
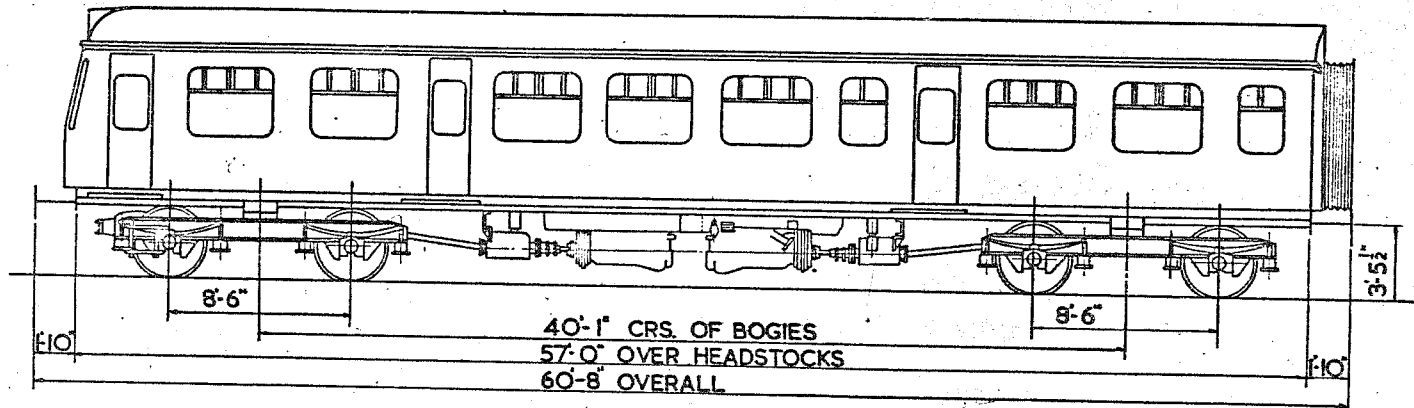

1 FIRST 12 SEATS
 2 SECONDS 53 SEATS
 1 LAVATORY
 1 DRIVING COMPARTMENT

2 X 150 H.P. B.U.T. ENGINE

QTY	LOT	VEHICLE NoS.	BUILT AT	TARE
26	30612.	Sc52011-Sc52036.	DERBY	35 TONS

MOTOR OPEN SECOND BRAKE (DIESEL ELECTRIC)

BR 650

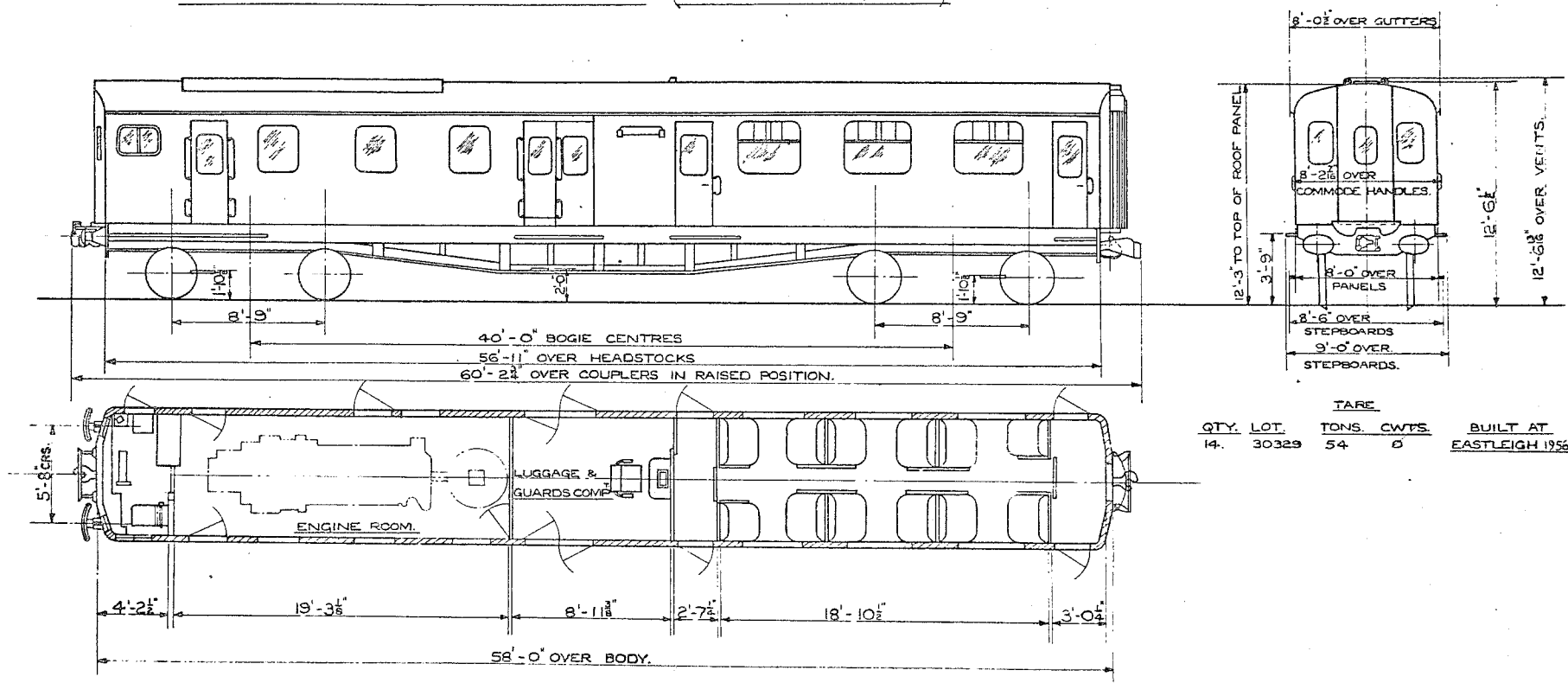

QTY.		TARE		BUILT AT	
LOT.	TONS.	CVTS.			
14.	54	0		EASTLEIGH 1956	
	30329				

22 SEATS

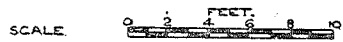

AIR BRAKE

MOTOR OPEN SECOND BRAKE (DIESEL ELECTRIC)

B.R. 652

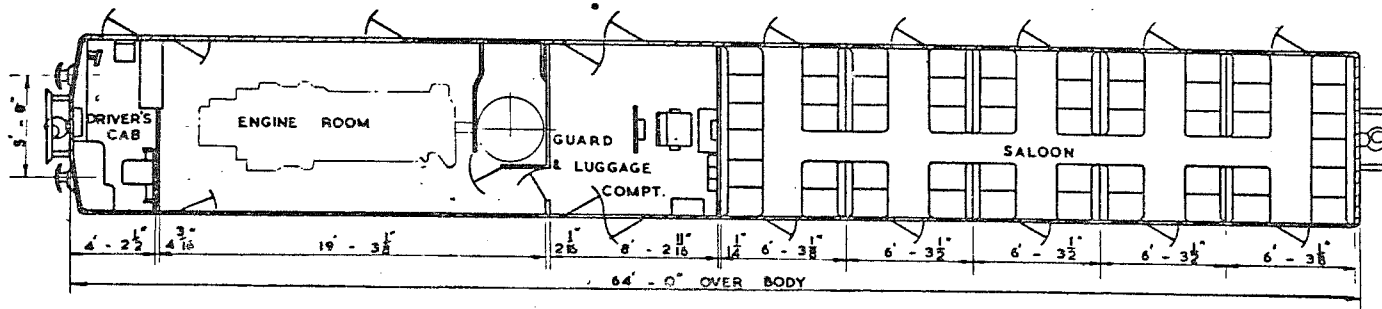
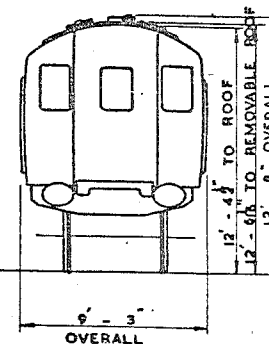
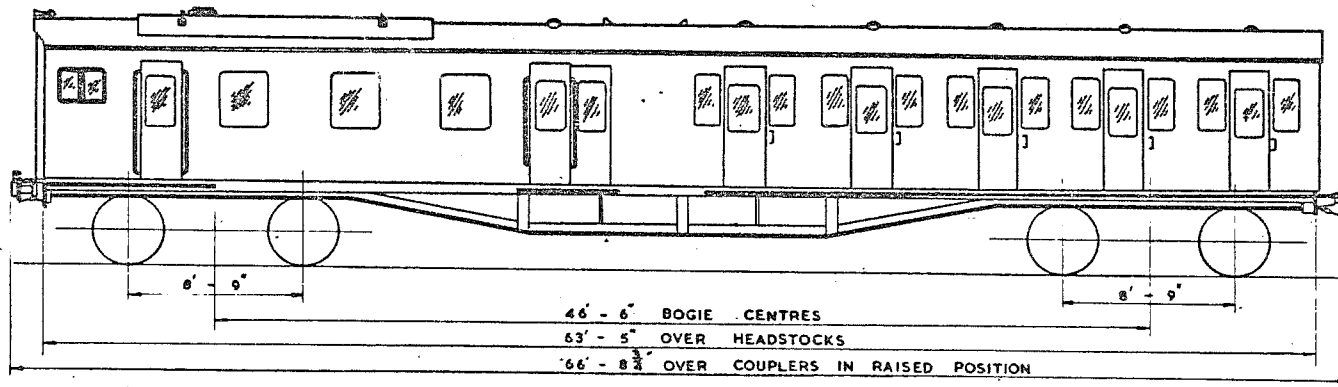

1 DRIVING COMPT. 1 GUARD & LUGGAGE COMPT
 1 SALOON 52 SEATS



MOTOR OPEN FIRST LAVATORY BRAKE (PULLMAN)

B.R. 653

(DIESEL ELECTRIC)

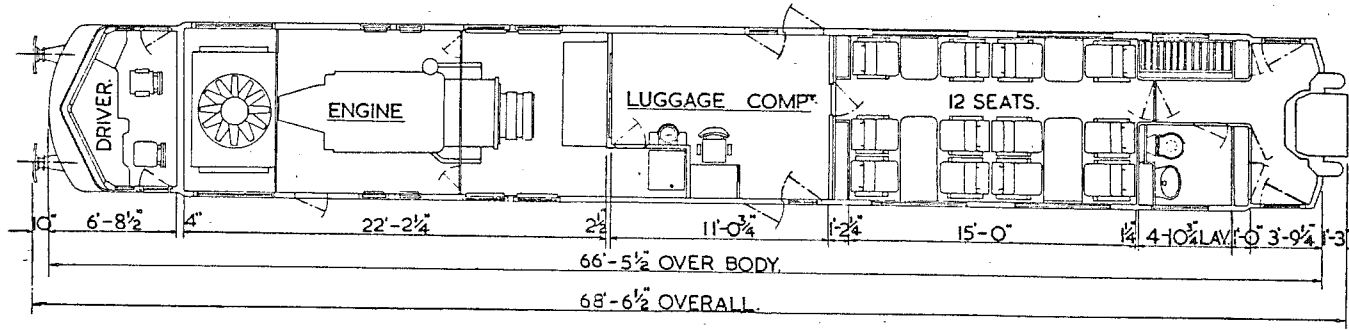
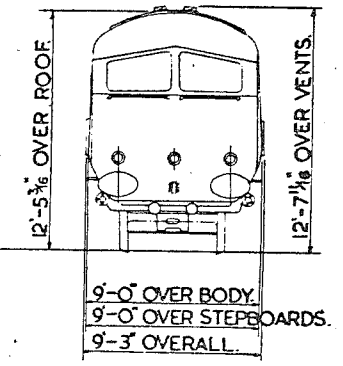
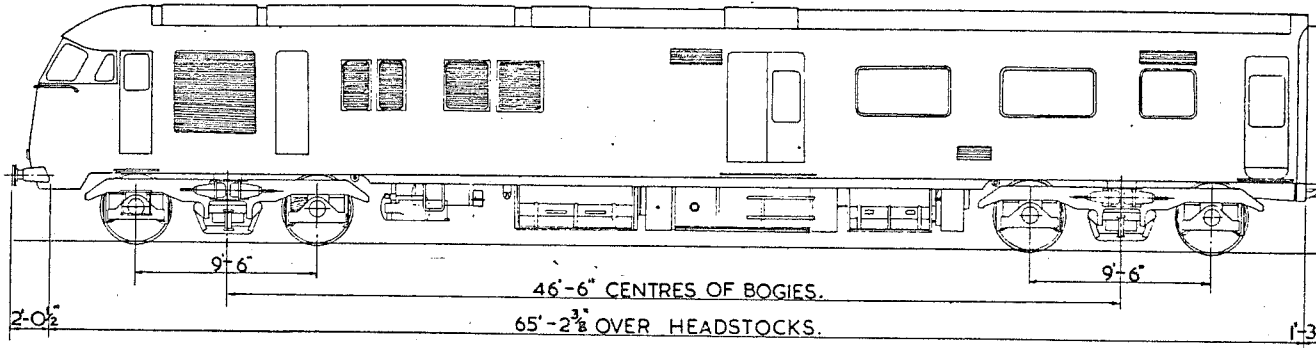

LOT Nos. VEHICLE Nos.
 30553. M. 60090.
 M. 60093.

BUILT BY. TARE
 METRO-CAMMELL. 67T.

- 1- FIRST 12 SEATS.
- 1- DRIVERS COMPARTMENT.
- 1- LAVATORY.

AIR BRAKES

MOTOR OPEN SECOND BRAKE (PULLMAN)
(DIESEL ELECTRIC)

B.R. 654

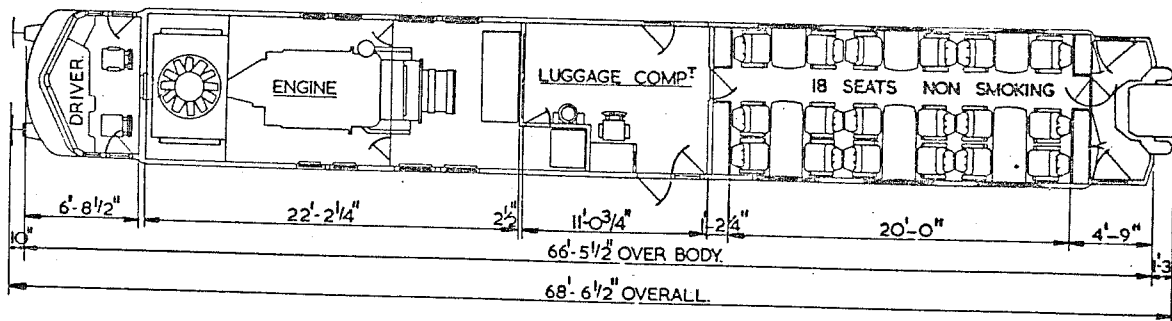
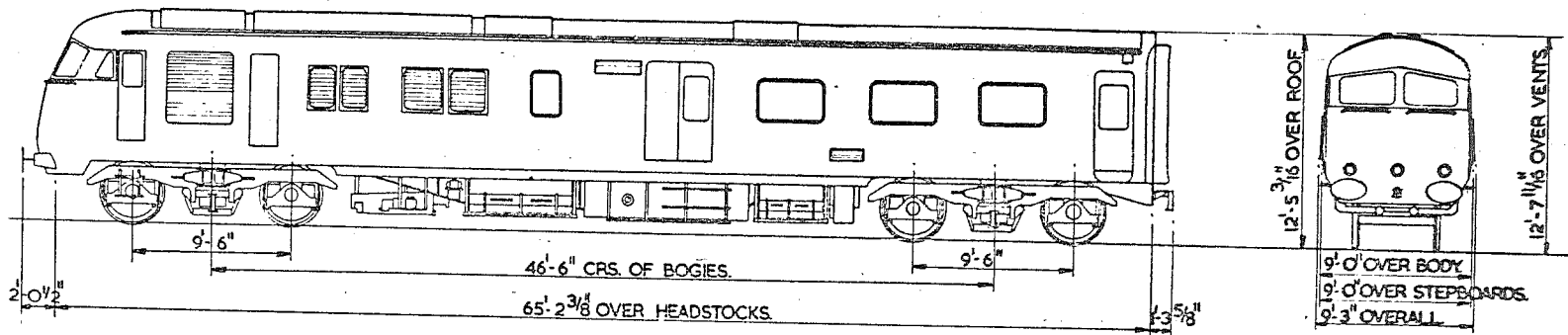

LOT N ^o	VEHICLE N ^{os}	BUILT BY	TARE
30554	W60094- W60099	METRO- CAMMELL	67 1/2 T

- 1- SECOND 18 SEATS
- 1- DRIVERS COMPARTMENT
- 1- LUGGAGE COMPARTMENT

AIR BRAKES

MOTOR OPEN SECOND BRAKE
(DIESEL ELECTRIC)

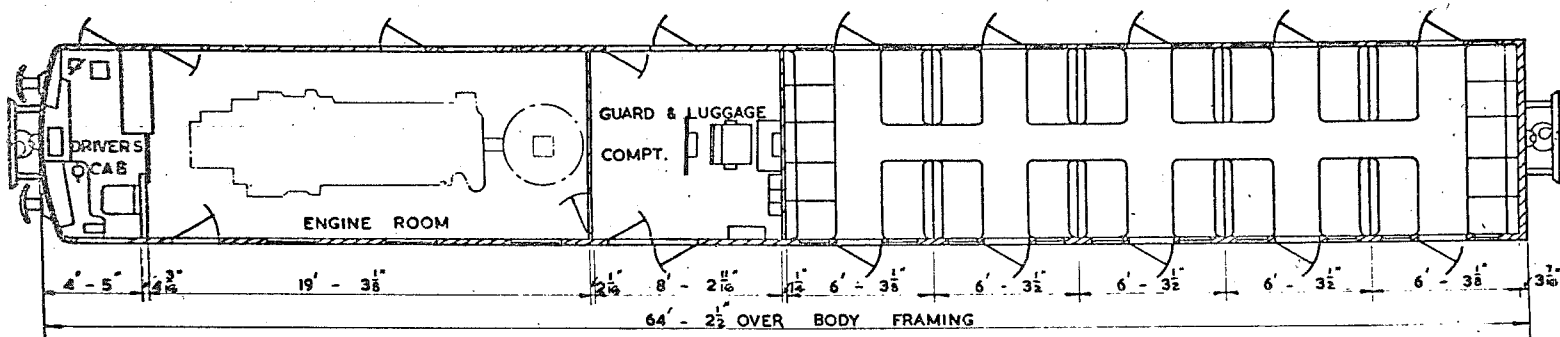
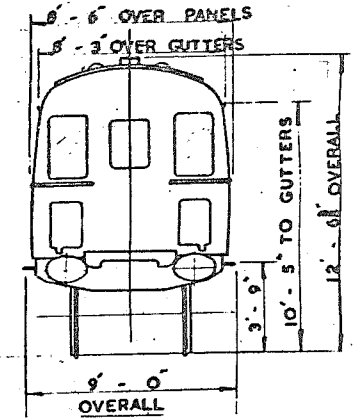
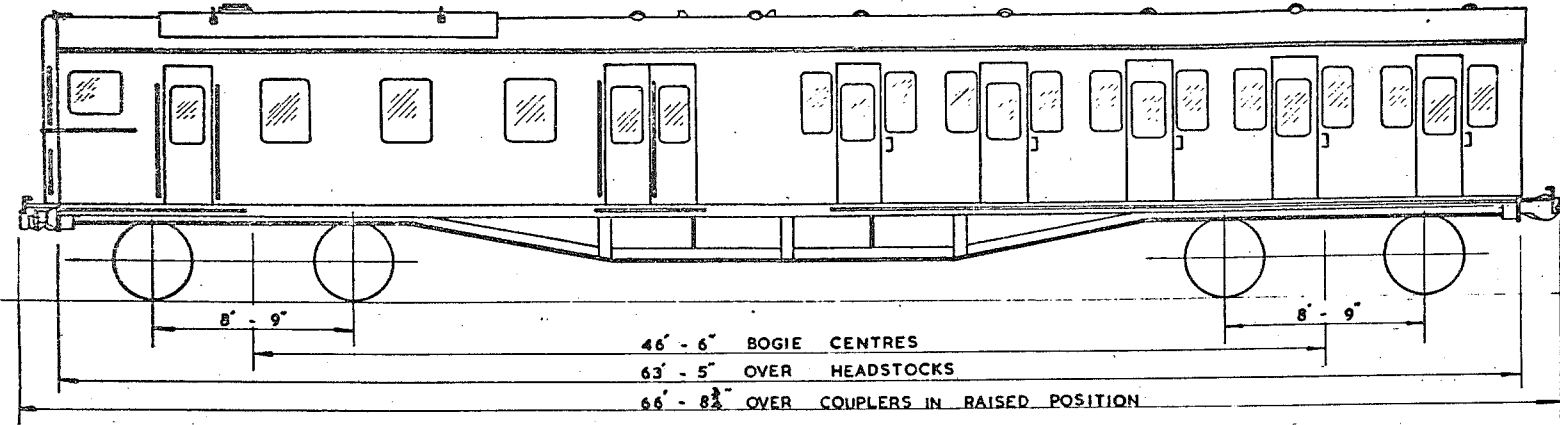

QTY.	LOT No.	VEHICLE Nos.
19	30625	60126 - 60144.

BUILT AT EASTLEIGH

1 DRIVING COMPT. 1 GUARD & LUGGAGE COMPT. 1 SALOON 42 SEATS AIR BRAKES



MOTOR OPEN SECOND BRAKE (DIESEL ELECTRIC)

B.R. 656.

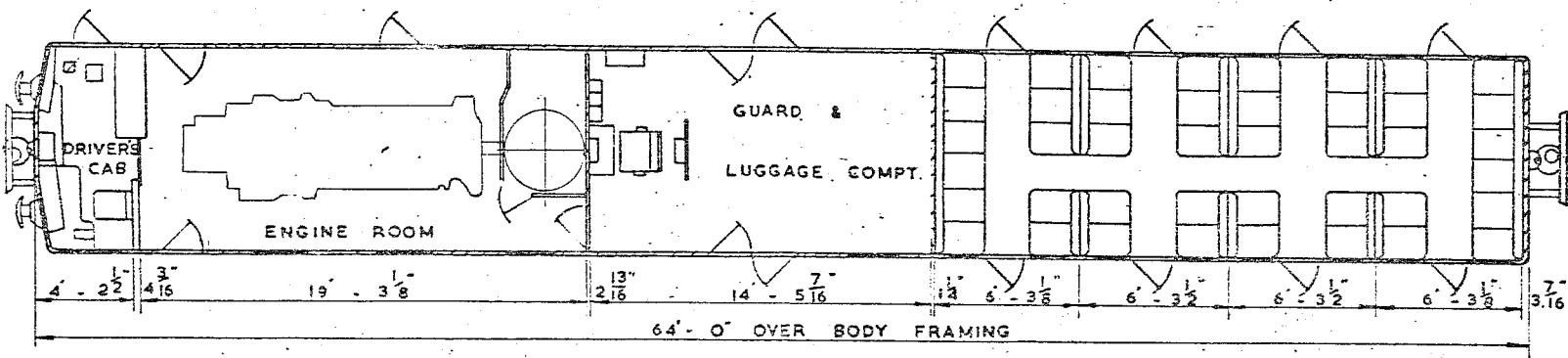
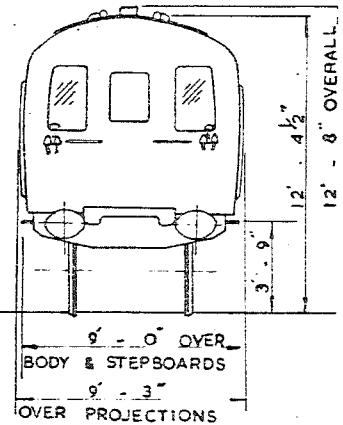
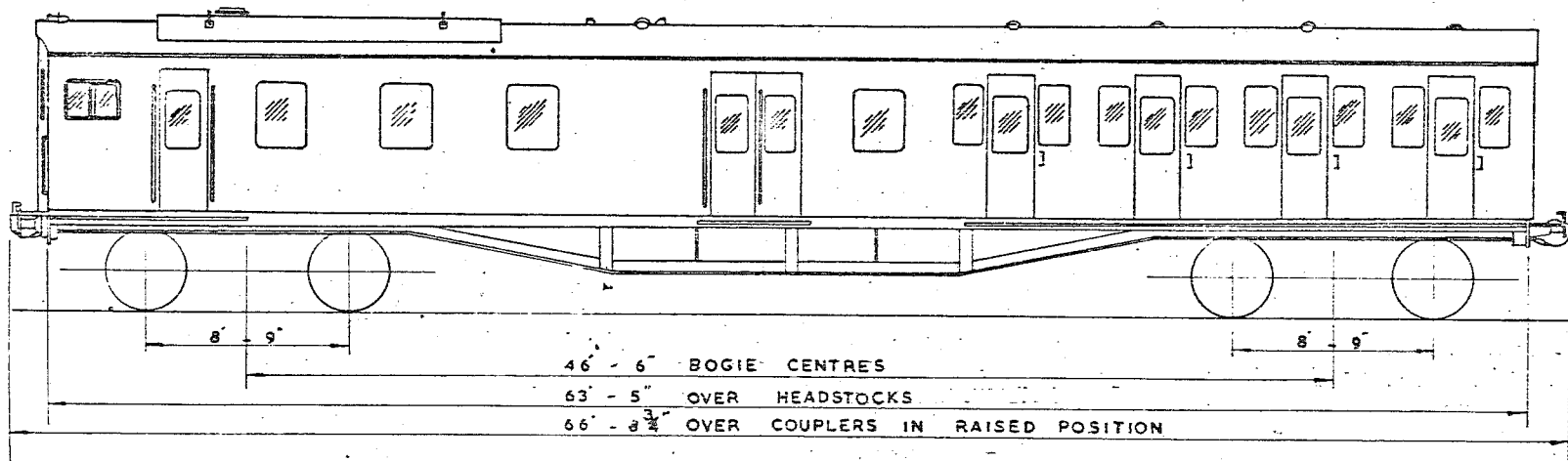

COMPRESSED AIR BRAKES

1 DRIVING COMPT. 1 GUARD & LUGGAGE COMPT. 1 SALOON 42 SEATS

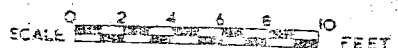

TRAILER CORRIDOR FIRST (DIESEL ELECTRIC)

B.R. 660

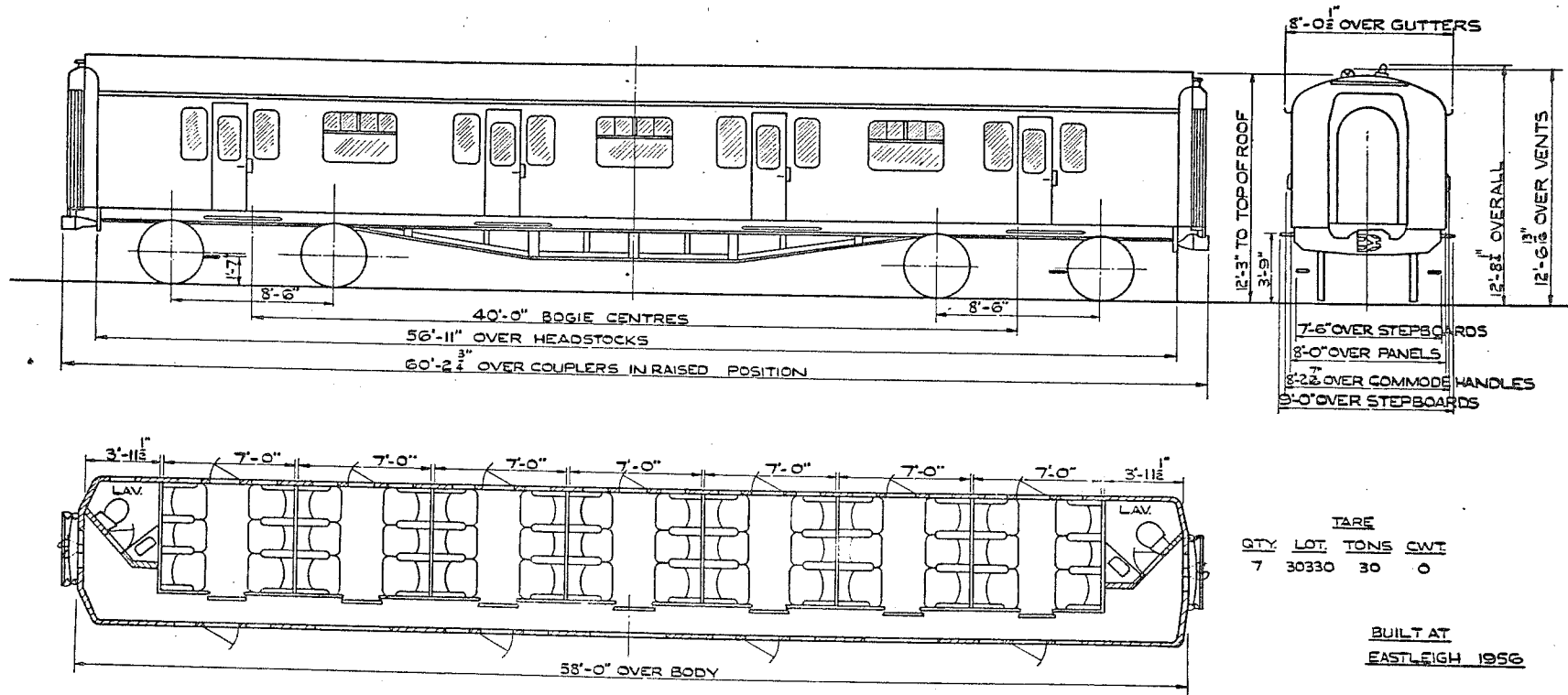

TARE

QTY.	LOT.	TONS	CWT.
7	30330	30	0

BUILT AT
EASTLEIGH 1956

42 SEATS

SCALE 0 2 4 6 8 10 FEET.

AIR BRAKE

TRAILER OPEN FIRST KITCHEN LAVATORY (PULLMAN)
DIESEL ELECTRIC
 (FITTED WITH AUXILIARY EQUIPMENT ENGINE)

B.R.662

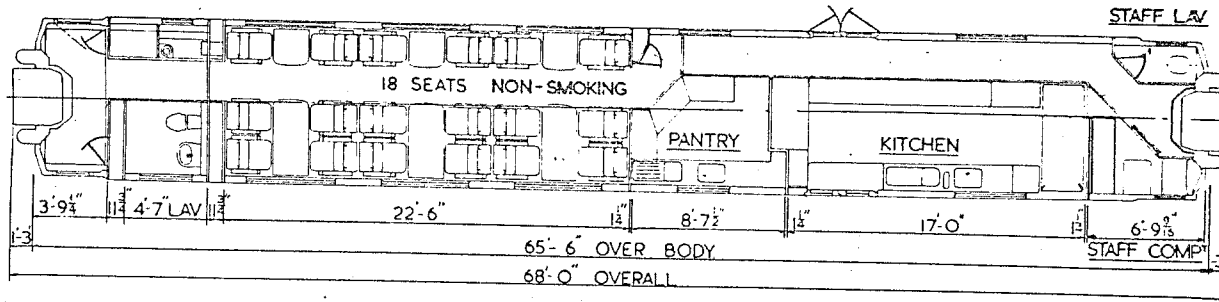
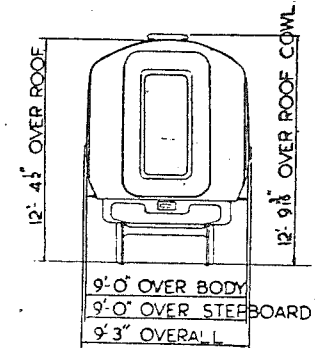
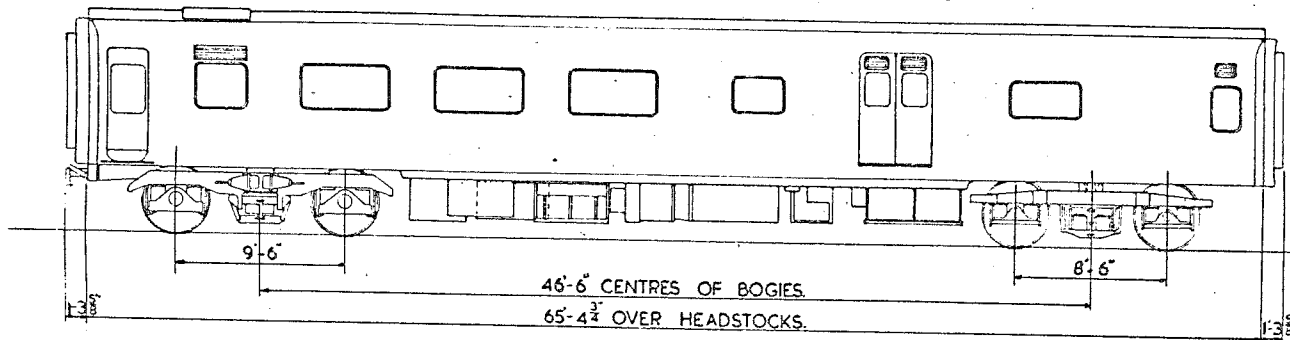

LOT Nos 30556

VEHICLE Nos M60730 M60733

BUILT BY METRO CAMMELL

TARE 49T

- 1-KITCHEN
- 1-FIRST 18 SEATS
- 1-LAVATORY
- 1-LAVATORY STAFF
- 1-STAFF ROOM

AIR BRAKES

TRAILER OPEN FIRST KITCHEN LAVATORY (PULLMAN)
(DIESEL ELECTRIC)

BR.663

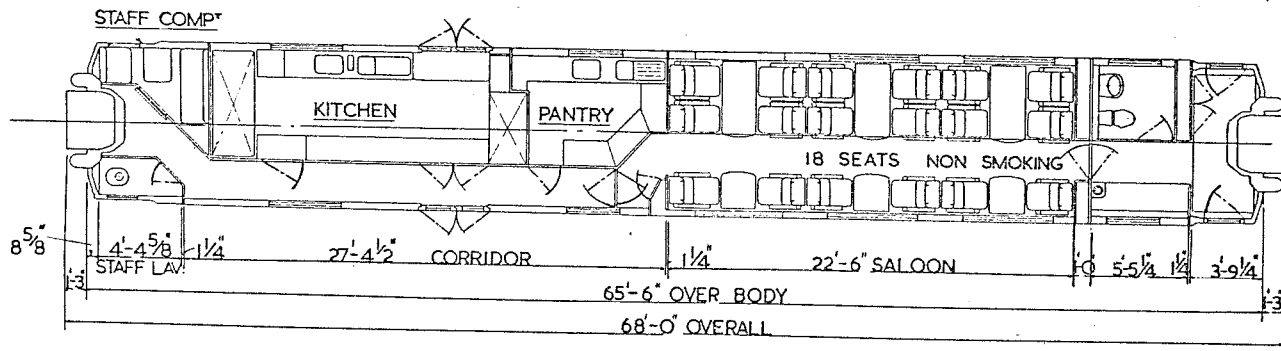
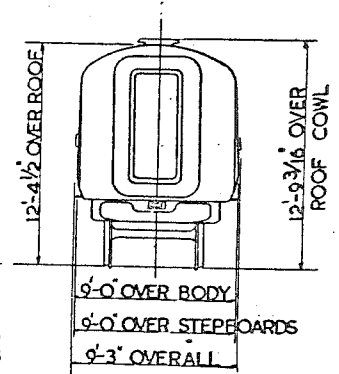
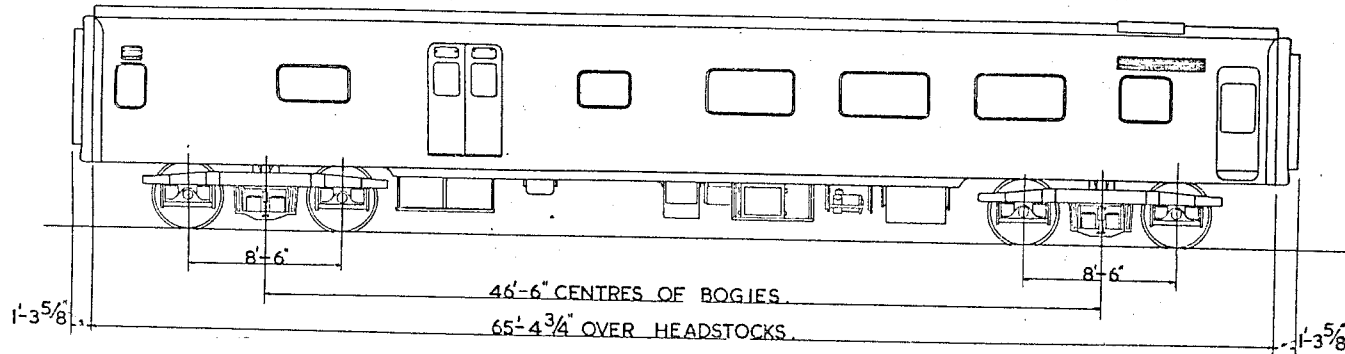

LOT Nos. VEHICLE Nos
30557 W60734 - W60739.

BUILT BY TARE
METRO-CAMMELL 36 T.

- 1- KITCHEN.
- 1- FIRST 18 SEATS.
- 1- LAVATORY.
- 1- LAVATORY STAFF.
- 1- STAFF ROOM.

AIR BRAKES

TRAILER OPEN FIRST LAVATORY (PULLMAN PARLOUR)
(DIESEL ELECTRIC)

B.R. 664

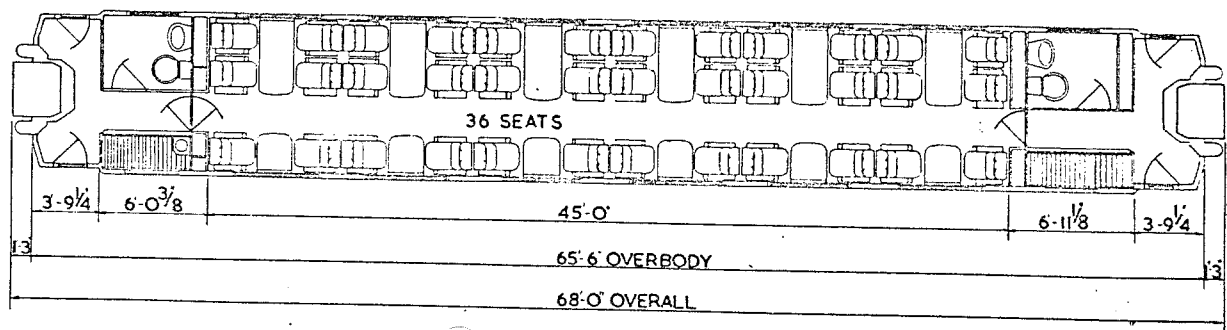
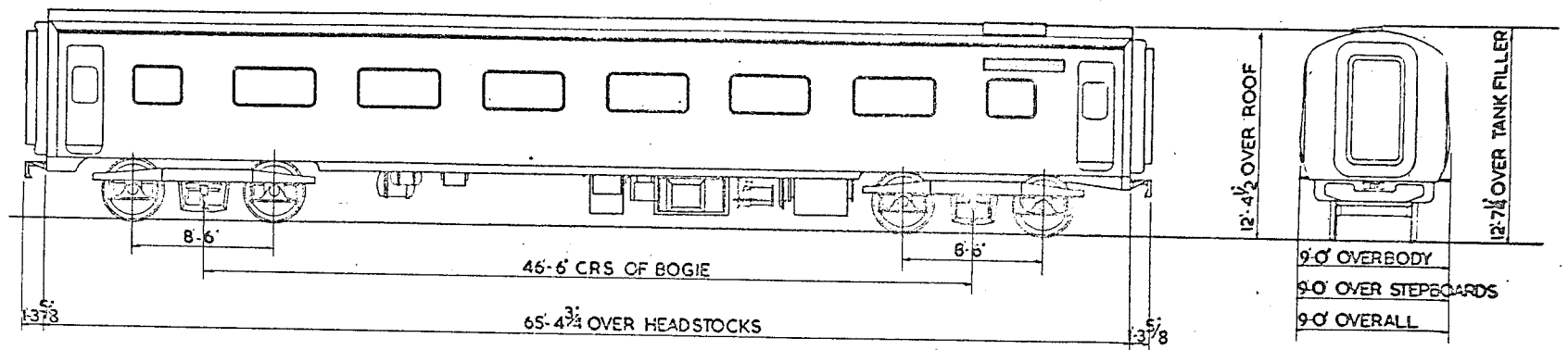

LOT N ^{OS}	VEHICLE N ^{OS}	BUILT BY	TARE
30558	M60740-M60743	METRO CANNELL	33T
	W60744-W60749		

- 1- FIRST 36 SEATS
- 2- LAVATORIES

4 BRAKES

BR. 667

TRAILER COMPOSITE SEMI-OPEN
(DIESEL ELECTRIC)

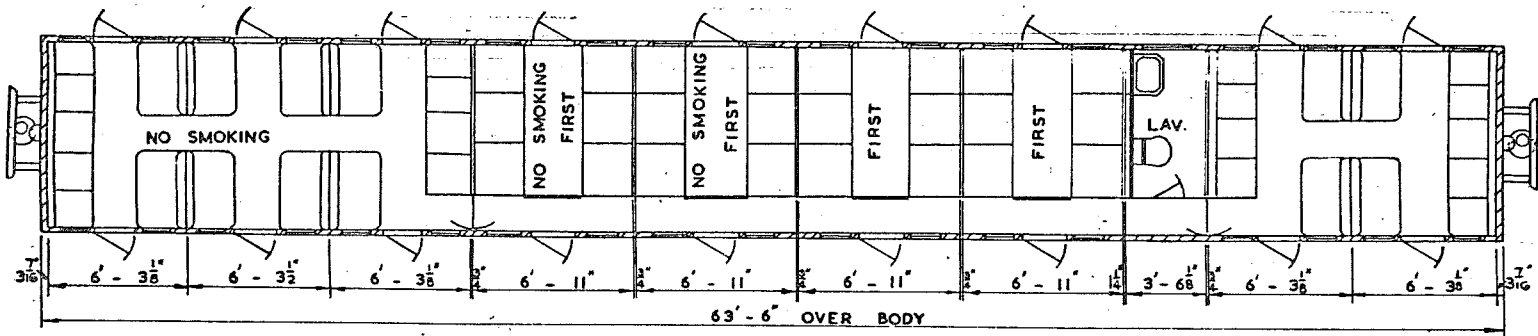
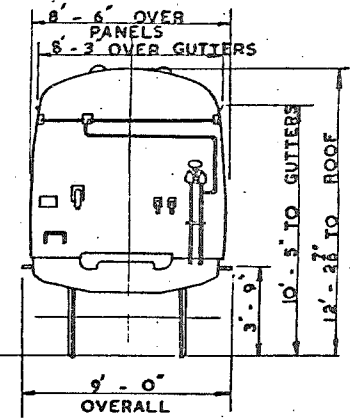
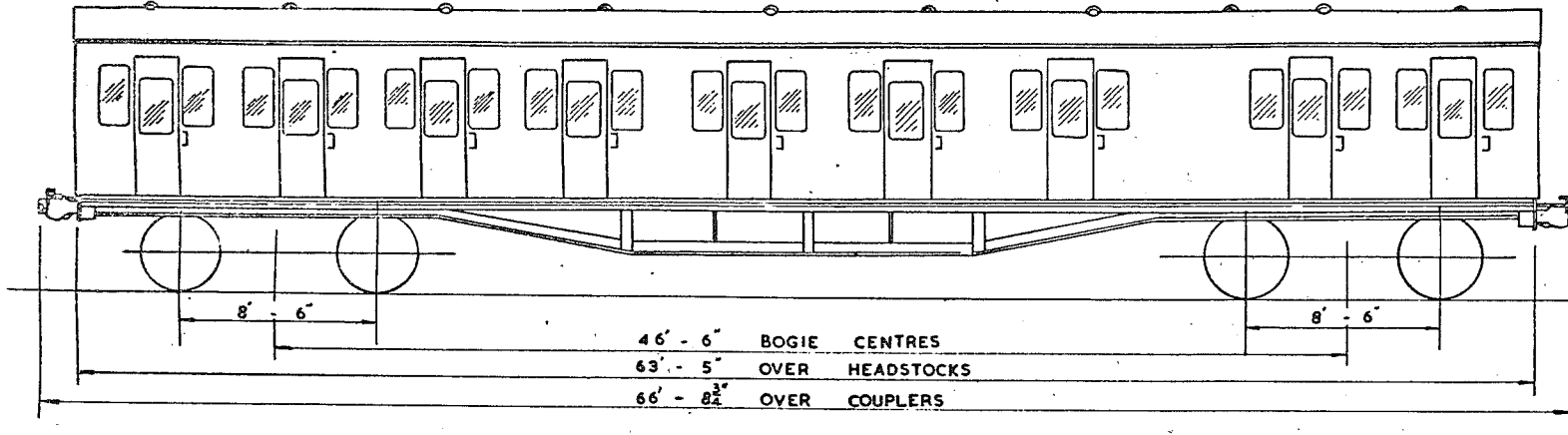

QTY. LOT No. VEHICLE No.
19 30626 60600 - 60618

BUILT AT EASTLEIGH

AIR BRAKES

2 SECOND 42 SEATS 4 FIRSTS 24 SEATS 1 LAV.



TRAILER OPEN SECOND (DIESEL ELECTRIC.)

B.R. 670.

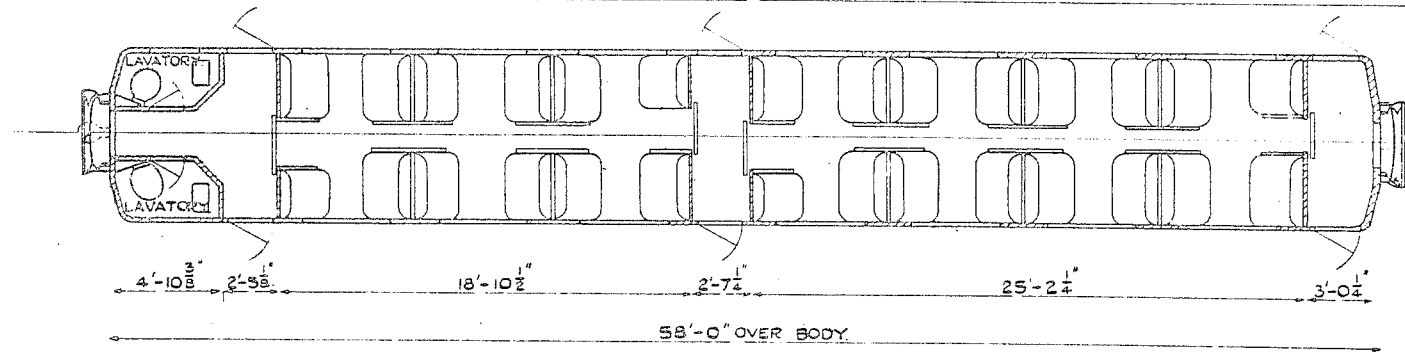
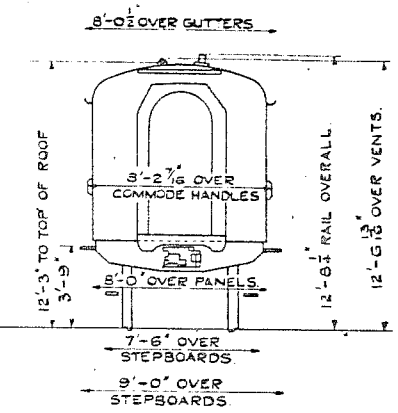
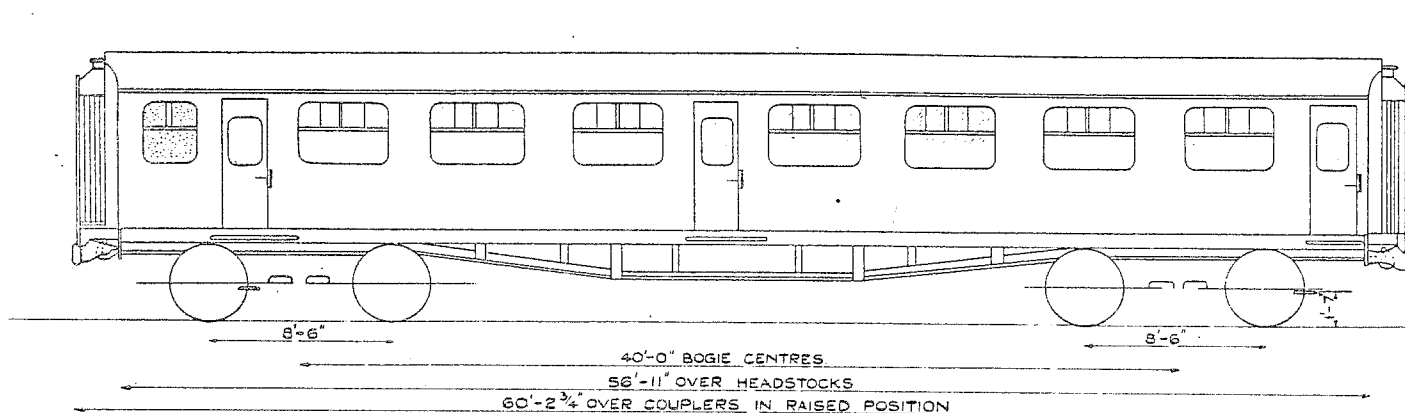

QTY	LOT	TARE TONS CWT.	BUILT AT
21	30331	29 0	EASTLEIGH 1956



SECOND - 52 SEATS AIR BRAKE

TRAILER OPEN SECOND

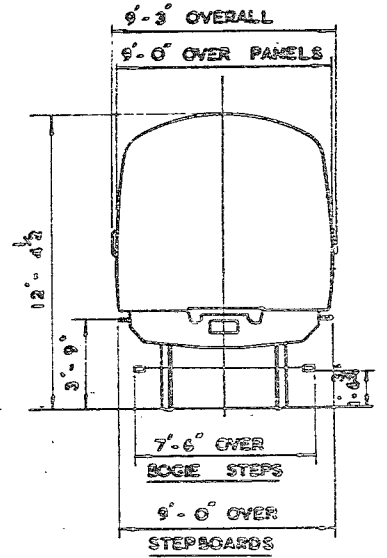
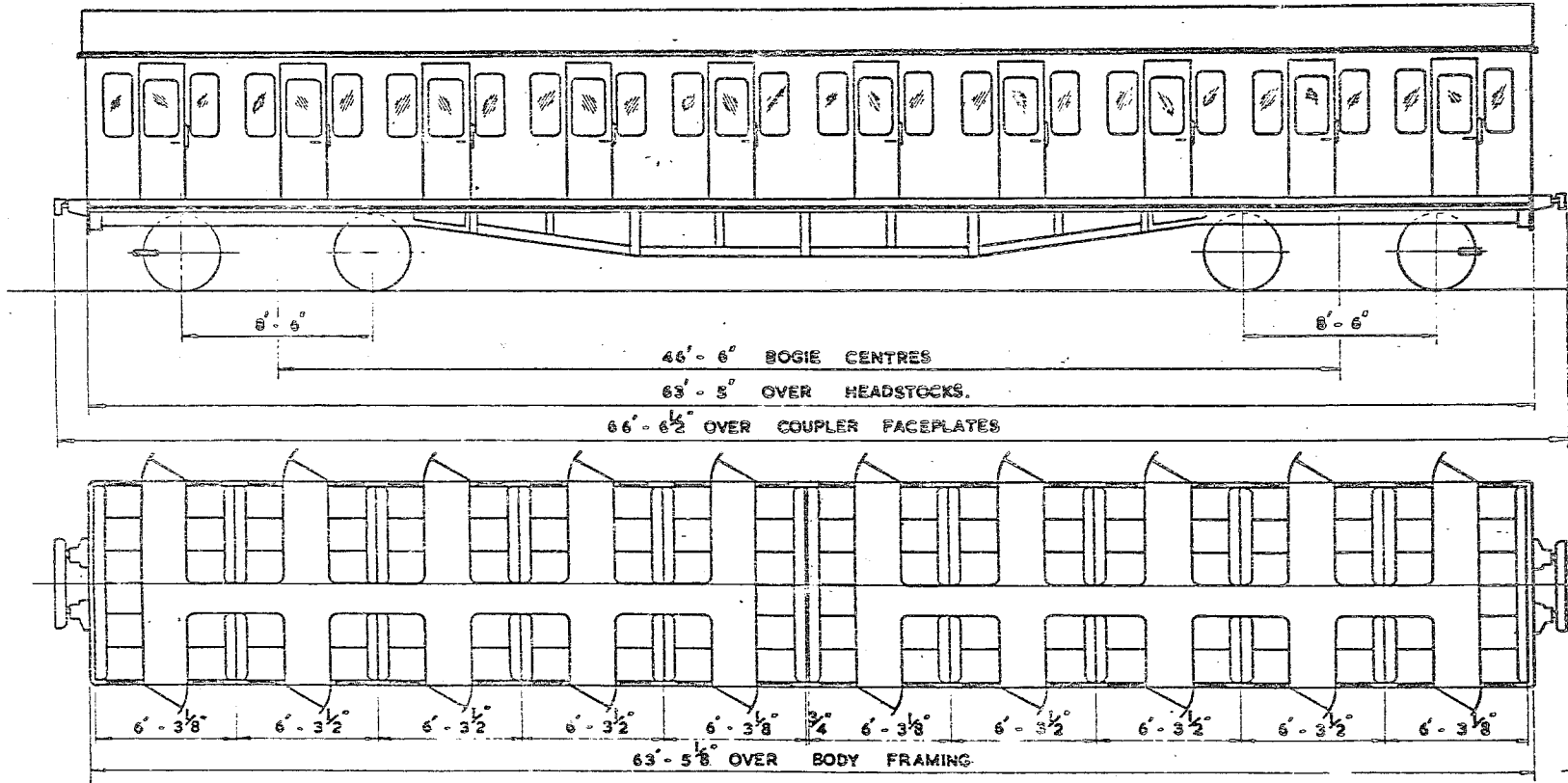

QTY	LOT	TARE	BUILT AT
		T. C.	
22	30542	30 0	EASTLEIGH 1959

2 SECONDS. 104 SEATS.

SCALE 0 2 4 6 8 10 FEET

AIR BRAKE.

TRAILER OPEN SECOND LAVATORY (PULLMAN)
(DIESEL ELECTRIC)

B.R. 673

(FITTED WITH AUXILIARY EQUIPMENT ENGINE)

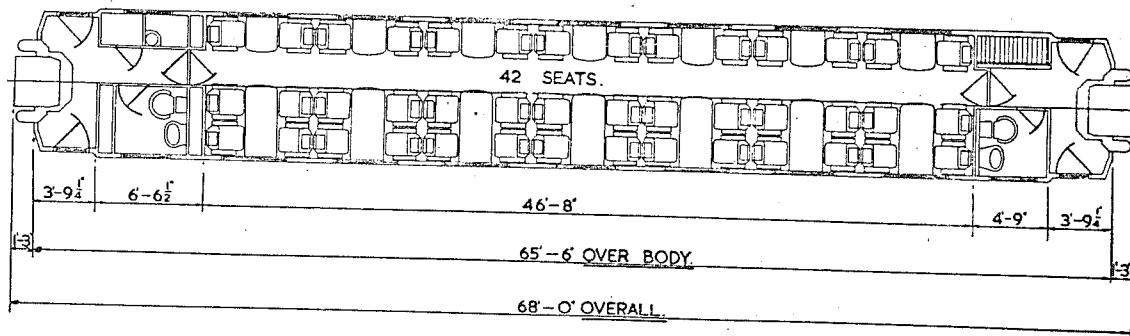
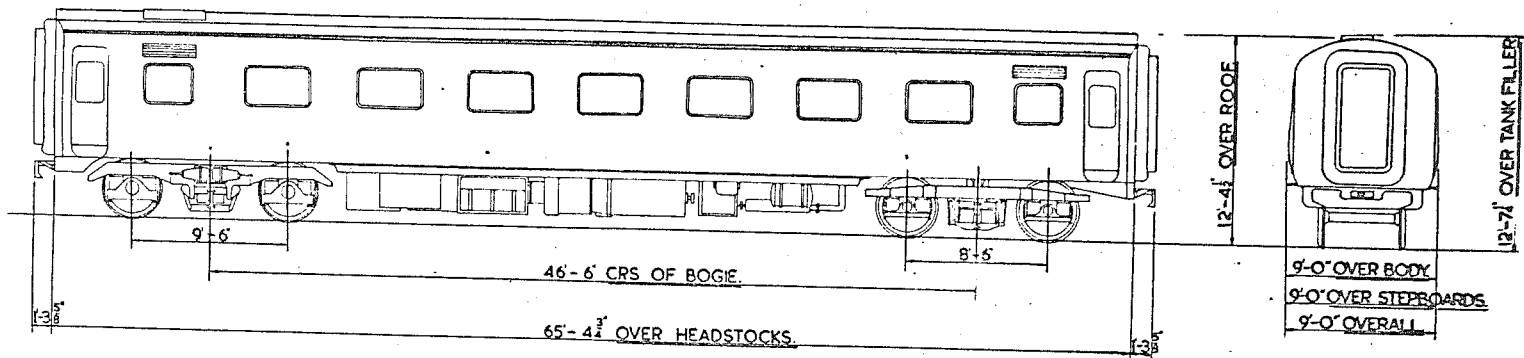

LOT Nos	VEHICLE Nos	BUILT BY	TARE
30555	W60644 - W60649	METRO-CAMMELL	45 1/2

1 - SECOND - 42 SEATS.

2 - LAVATORIES.

AIR BRAKES

DRIVING TRAILER COMPOSITE

DIESEL ELECTRIC

BR.679

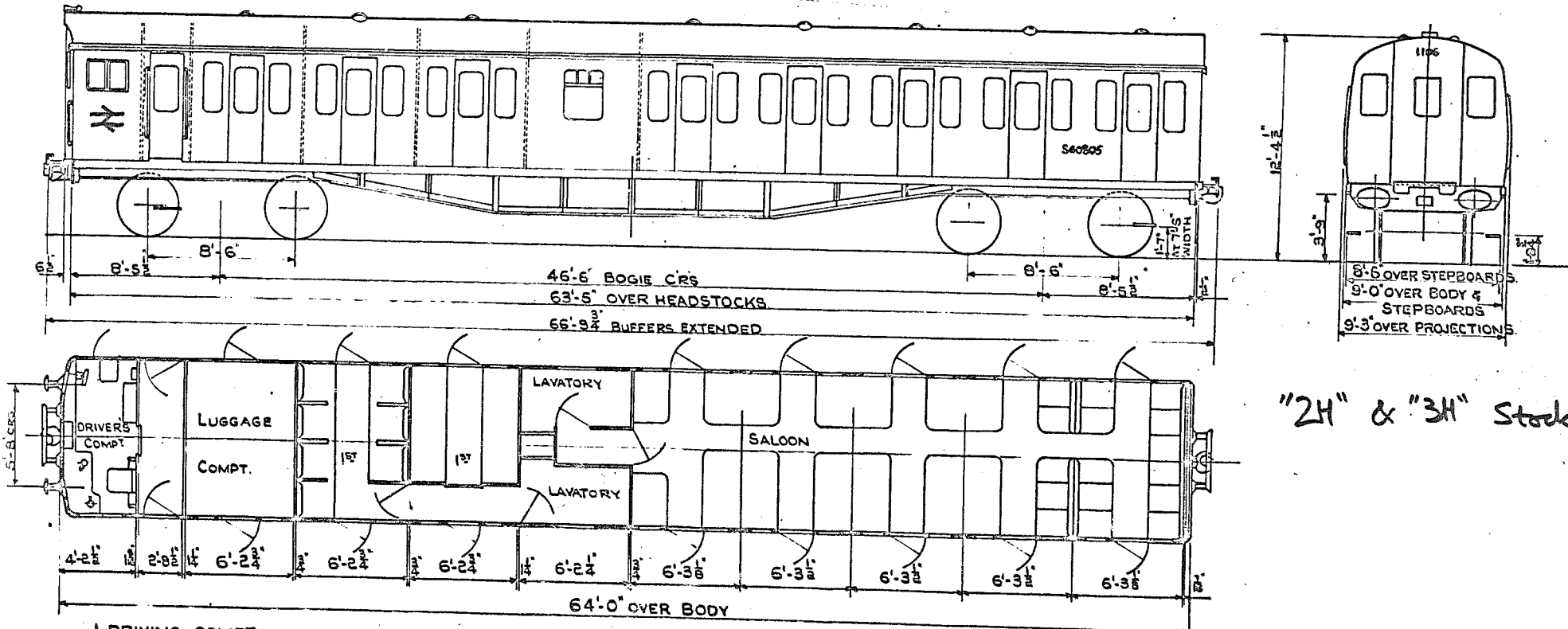

"2H" & "3H" Stock

- 1 DRIVING COMPT
- 1 LUGGAGE COMPT.
- 2 FIRSTS. 13 SEATS
- 1 OPEN SALOON 50 SEATS.



DRIVING TRAILER COMPOSITE

B. R. 680

DIESEL ELECTRIC

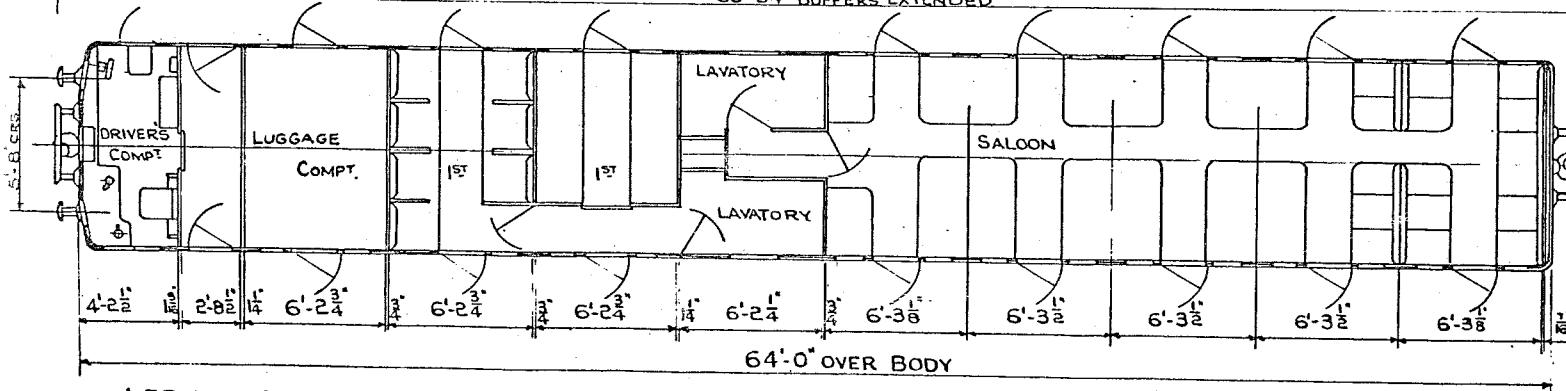
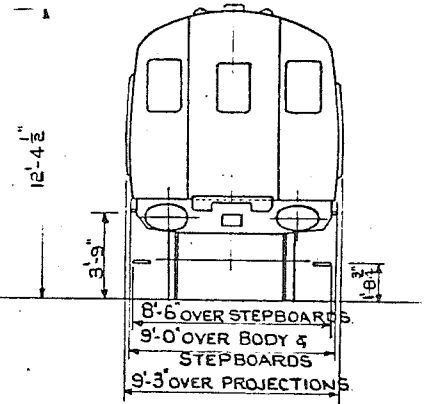
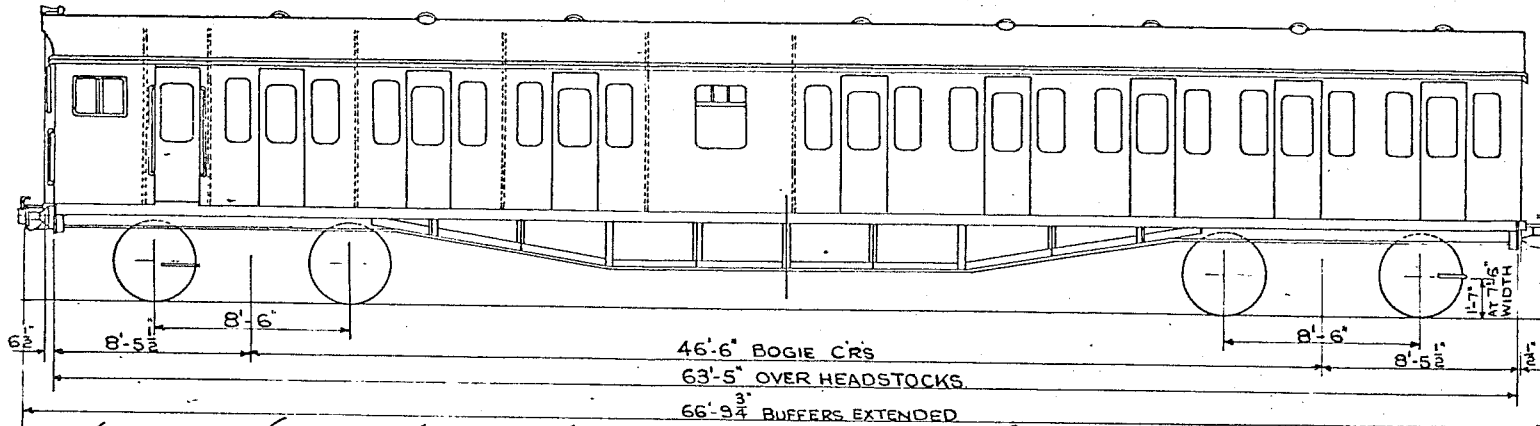

- 1 DRIVING COMPT
- 2 FIRSTS. 13 SEATS
- 1 OPEN SALOON 50 SEATS.

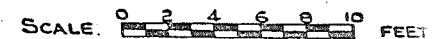

B R. 681.

DRIVING TRAILER OPEN SECOND
(DIESEL ELECTRIC)

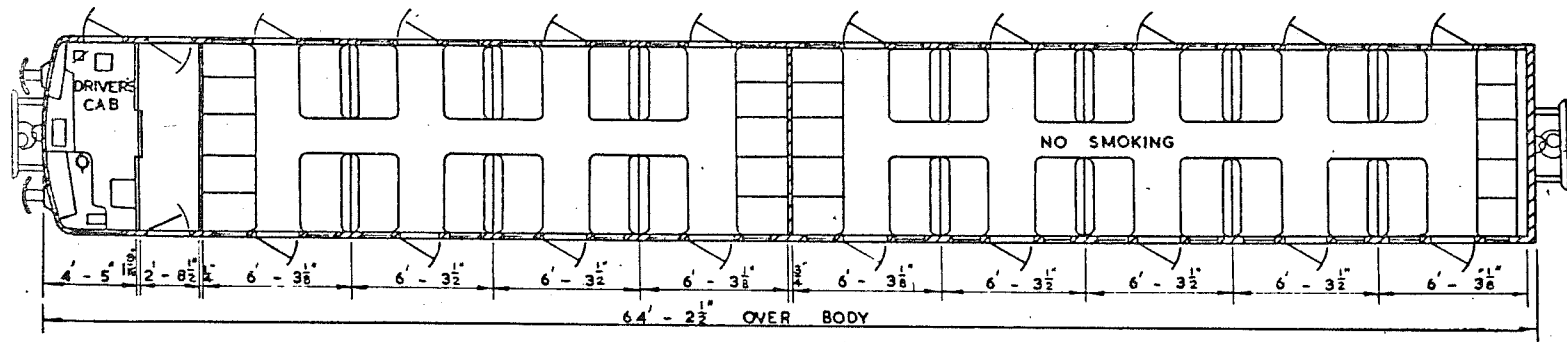
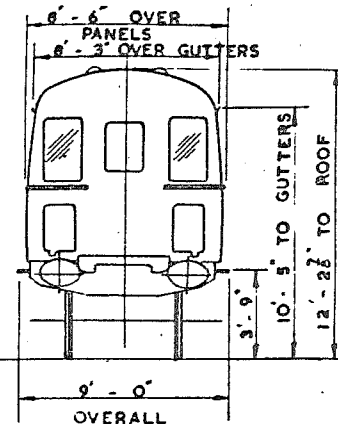
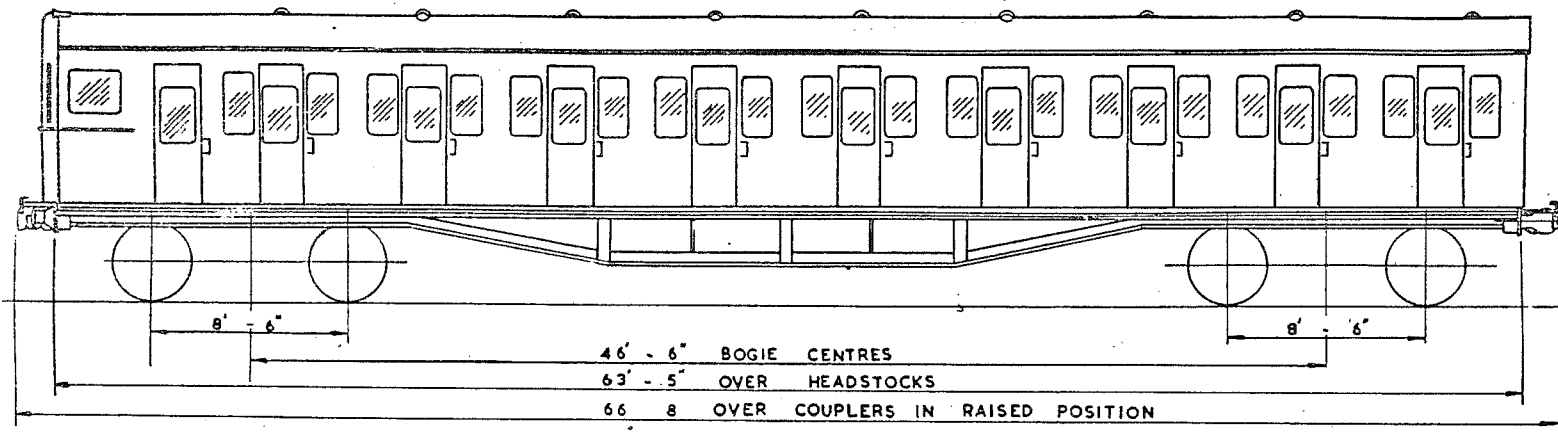

QTY.	LOT No.	VEHICLE No.
19	30627	60900 - 60918

BUILT AT EASTLEIGH

AIR BRAKES

2 SECONDS 76 SEATS. 1 DRIVING COMPT.

